



Meter-Flo® Pump Packages



**Circulating
Oil Systems**

Meterflo® Pump Packages For System Savings

Meterflo packages are intended for relatively large systems (100 to 1,000 points), with a total requirement of up to 245 cubic inches per minute supplied by electric motor driven gear pumps. Meterflo pump packages are typically used with Trabon® MSP, MXP, and MGO series progressive divider valves, which accurately piston-proportion the oil input to a multiple number of lubrication points. A big advantage of the positive piston displacement is the reduction in total lube volume required as compared to unmetered systems. This results in much smaller pumps, tubing sizes, and

filter capacity. Motor horsepower is also reduced, with savings in frame size and energy costs.

Graco's Meterflo pump packages come with a wide assortment of displacements, options, and accessories to handle a wide variety of applications. These pre-assembled packages are ready for connection to Trabon series progressive lube systems, operating in either a terminating or circulating mode.

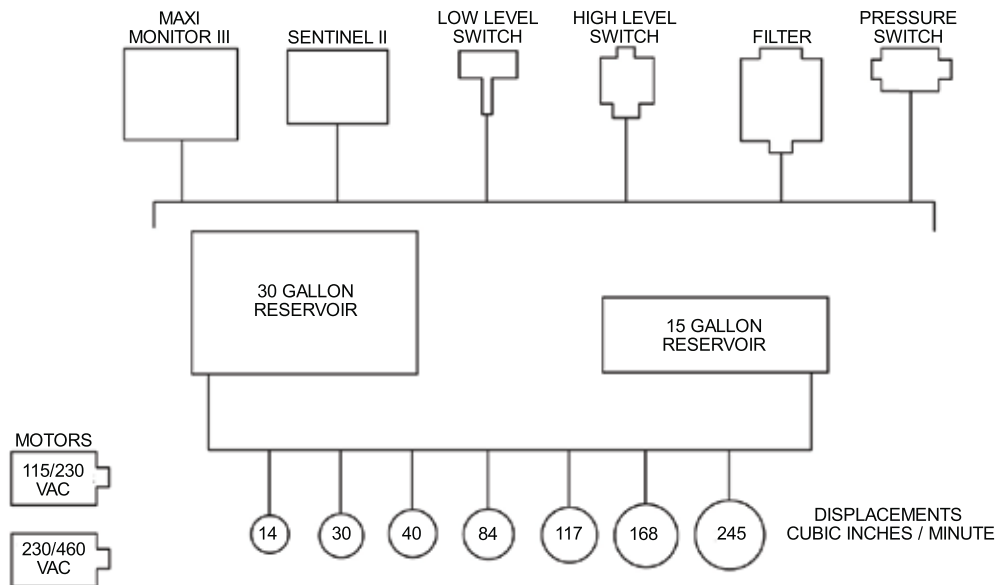

FEATURES/BENEFITS

- Flooded suction pumps for maximum performance
- Full rated output at rated pressure
- Seven different displacements from 14 to 245 in³/min
- System protected with 1,200 psi internal relief valve
- External relief (adjustable) factory set @ 1,000 psi
- 15 and 30 gallon reservoirs with level gauge, filler/breather, return line/pressure fill port, suction line fitted with strainer and shut-off valve for ease of service
- Options and accessories include low level, high level, and pressure switches; pump housing safety covers; filters; controllers; and 115 to 460 VAC motors

UNLIMITED APPLICATIONS

Meterflo packages are used in a wide range of applications, from individual machines to high volume production lines. A few of the many applications include:

- Stamping presses
- Textile mills
- Transfer lines
- Plastic sheeters
- Printing presses
- Plastic molding machines
- Coil processing equipment
- Metal turning machines
- Primary metal mills
- Food processing equipment

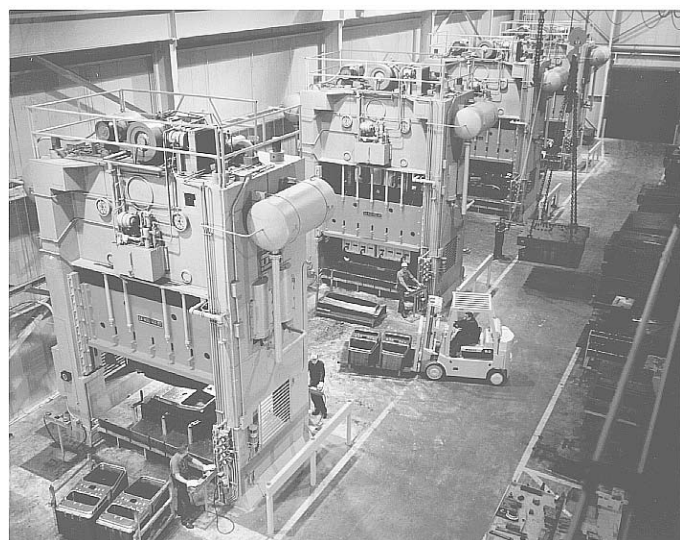

DESCRIPTION

The Meter-Flo pump package consists of various user selected options. These are listed below to help select the unit best suited for the application in mind.

Pump

Meter-Flo packages come with rugged gear pumps made of hardened steel gears, precision ground to assure a close fit, efficient operation and long-lasting dependability. An internal relief valve provides redundant protection for the pump, in case the external relief is disabled for any reason. Output capabilities range from 14 to 245 cu.in./min.

Motor

The gear pump is driven by a direct coupled 1/2 horsepower motor that can be specified as either 15/230 or 230/460 VAC. These are single phase foot mount 56 frame motors turning a 1725 RPM.

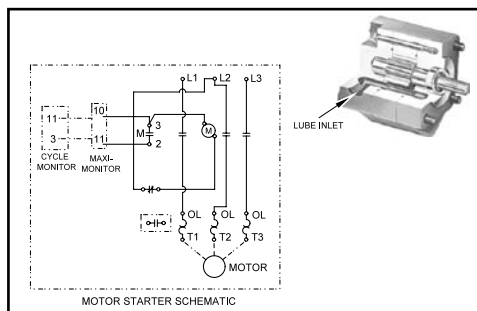

Figure 1. Motor Starter Used with Graco® Controllers

Reservoirs

Reservoirs come in 15 and 30 gallon capacities, providing volume multiples which are 30 to 500 times the maximum pump displacements. These large multiples allow for high volume draw-downs and return surges for circulating applications, such as stamping presses. Standard reservoir features include a top mounted filler/strainer, visual level gauge, 140 micron suction strainer, and a 1/2 in NPSF port for use with a return line or for pressurized filling. Reservoirs can be floor mounted by using four holes provided in the base flanges for 1/2 bolts. Top filling is made easy by a maximum reservoir height of less than 34 in. The filler/breather cap is retained by a chain assembly, and has a 30 mesh fill screen.

Reservoir Fill Filter Option

This option utilizes the Trabon non-bypassing style spin-on filter assembly to prevent contamination from entering the reservoir. It comes complete with a 0 to 160 psi pressure gauge and external bypass to protect the element against line surges and high differential pressures due to contamination. It is compatible with petroleum based oil.

Pressure Switch Option

The pressure switch provides an electrical signal in case of excessive pressure, indicating a blockage or restriction in the lube system. This signal can be used to trip a warning device or to shut the machine down. The pressure switch is adjustable, factory set at 800 psi, with recommended settings at 50 to 100 psi above normal operating pressure highs.

Pressure Filter Option

The Meter-Flo discharge filter utilizes a non-bypassing industry standard “HF2” design 10 or 20 micron element. Filter assemblies are available with either visual or combination visual/electrical element condition indicator set to a pressure differential of 50 psi, indicating the filter element requires changing.

High Level Switch Option

The high level switch is primarily used when the Meter-Flo package is utilized with automatic refill system. The high level switch provides an electric signal to shut off lube supply to the reservoir.

Controller Option

The Meter-Flo unit also has an optional control package to operate and monitor the lube system on either a continuous or intermittent cycle.

The WMP Maxi-Flo will schedule lube periods on either a time basis or machine stroke/cycle count at a user determined frequency. Once a lube period begins, the WMP controller will also monitor lube system operation through a cycle switch or proximity switch attached to the divider valve. As long as the WMP receives the proper number of actuations from the cycle/proximity switch within a monitored interval for each lube period, system operation will be considered normal. If the monitor interval expires before the proper number of actuations occur, a fault signal will be generated. The fault can be caused by blockages, defective pump, open main line, etc., but this is a warning that the lube system is not operating properly and trouble shooting methods should be taken.

The Lube Sentinel II option monitors the lube system when run on a continuous basis. Through the use of a timer circuit and a cycle/proximity switch mounted on a divider valve, the Lube Sentinel II detects reduction in flow rates (clogged filter) as well as no-flow (line blockage) and signals this malfunction.

System Start-up

When a lube system is first started, it is necessary to prime and bleed the air out of the lube lines, and check for proper operation. Refer to Graco Bulletins L30103 and L30101 for information on these procedures.

APPLICATION INFORMATION

Calculating Flow Requirements

Before selecting a Meterflo pump size, the flow requirements of the lube system must be carefully estimated to avoid dumping excess flow over the external relief valve. On the other hand, a small amount of excess capacity is desirable to insure that all divider valves are cycled during each lube period. Also, if points are likely to be added in the future, there should be adequate pump capacity to handle these.

$$V = A \times T$$

V = lubricant replacement volume

A = equivalent area to be lubricated

T = lubricant film thickness

Total lube system flow is calculated by adding up all of the individual lube point volumes required per unit of time. These individual volumes are determined by using the formulas in Graco® Bulletin 20115. Select the appropriate pump displacement from the "HOW TO ORDER" table on page 8.

Estimating System Pressure

Lube system pressure affects pumping unit costs, tubing costs, and energy costs. Therefore, system design should strive for the lowest practical pressure, balancing pumping unit costs with divider valve and tubing costs.

As a rule of thumb, the pressure loss through all tubing and divider valves excluding the lube points themselves, should not exceed 500 psi. This part of the system pressure is defined as "free operating pressure" (i.e., divider valve lines not connected to lube points).

A free operating pressure of 500 psi allows nearly 500 psi injection pressure created by the lube points, and keeps total system pressure under 1,000 psi. The injection pressure of individual lube points depends on the sizes of passageways and clearances around the components to be lubricated. These individual pressures are not additive (see discussion below on free operating pressure).

Free Operating Pressure

An estimate of free operating pressure is obtained by adding up (A) line loss from pump to master divider valve, (B) master divider valve loss, (C) the maximum loss using the worst case combination of secondary divider valve loss and line loss leading

to that valve's inlet, and (D) the maximum loss for the worst case line from the divider valve used in (C) to the lube point for that line. An example is shown in Figure 2.

Clearly, an approximate layout of the system will be required to arrive at estimated tubing lengths. After this is done, Figures 4, 5a, 5b, and 5c. can be used to estimate system pressure drop. The flow number to be used in these figures is determined by multiplying oil viscosity times the flow rate in the line or divider being estimated. Remember that divider valve inlet flow will be proportioned among the outlet lines according to the displacements of individual valve sections. This is illustrated in Figure 3. Use the procedures in Graco® Bulletin 20101 to calculate the basic ratios.

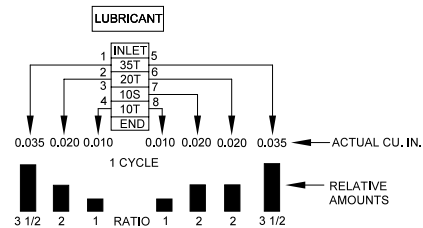

Figure 3. Calculating Flow in Individual Series Progressive Lube Lines

Tubing Pressure Drop

By selecting appropriate divider valves and tubing sizes, a system can be designed that limits pressure to an acceptable value. This may involve the use of a slightly larger divider valve or tubing size than originally planned.

However, if the tubing guidelines in Table 1 are used, this should help avoid redesigns due to excessive pressure drop:

Table 1. Recommended Tubing Sizes for Oil

Divider Valve Model	Outlet Lines	Inlet Line
MS	3/16 inch I.D.	1/4 inch I.D.
MXP	1/4 inch I.D.	3/8 inch I.D.
MGO	3/8 inch I.D.	1/2 inch I.D.

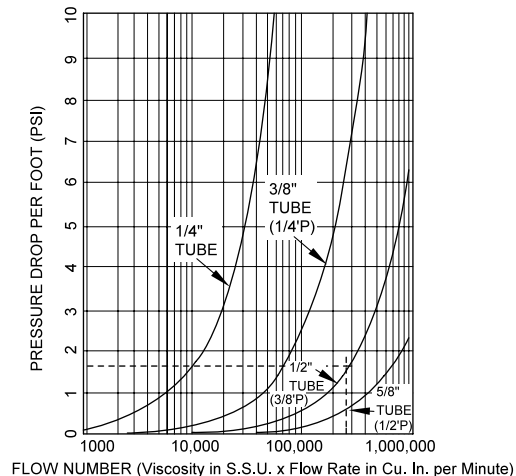

Figure 4. Approximate Pressure Drop Per Foot for Various Tube Sizes

FIGURES BASED ON FOLLOWING
 PUMP DISCHARGE—40 CU. IN./MIN.
 OIL VISCOSITY—3,000 S.S.U. SAE TO AT 70°F

	PSI	SYSTEM 1	FLOW RATE	SYSTEM 2	PSI		
A	5	20'-5/8 T	40 CU. IN./M.	20'-1/2 T	16	A	
B	80	MXP MASTER	40 CU. IN./M.	MXP MASTER	80	B	
C	6	20'-1/2 T	5 CU. IN./M.	20'-3/8 T	24	C	
D	33	MXP SECOND	15 CU. IN./M.	MXP SECOND	140	D	
E	4	10'-3/8 T	15 CU. IN./M.	10'-1/4 T	26	E	
	128	TOTAL "FREE" SYSTEM PRESSURE				286	

Figure 2. Example of Free Operating Pressure Calculation

Divider Valve Pressure Drop

The same flow numbers calculated earlier can be used to estimate the pressure drop through each divider valve. This is done by using the nomographs in Figures 5a, 5b, and 5c. The flow rate to be used is the magnitude at the inlet of the divider valve.

Figure 5a.
Pressure Drop Through Any MGO Divider Valve

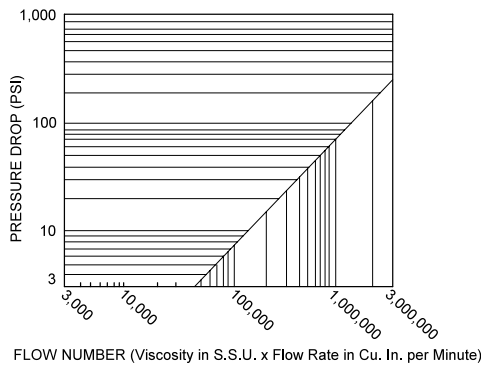

Figure 5b.
Pressure Drop Through Any MXP Divider Valve

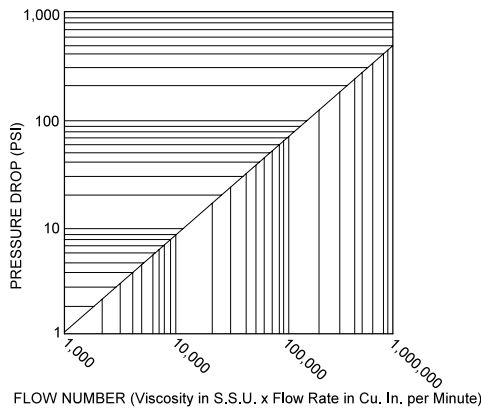

Figure 5c.
Pressure Drop Through Any MSP Divider Valve

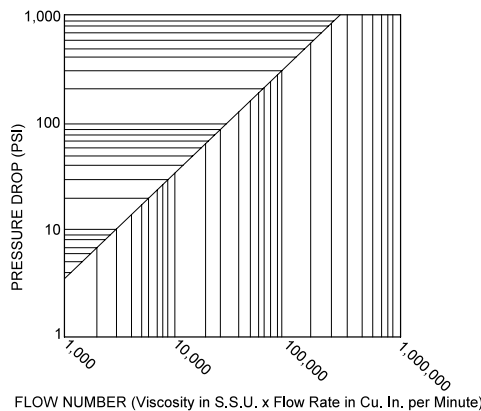

Figure 5. Pressure Loss Nomographs for Graco Divider Valves

If a specific lubricant has not been selected, oil viscosity can be estimated from Table 2. It is a good idea to make pressure loss calculations for cold start-up conditions, as well as for normal operating temperatures. If the temperature of the oil is low enough, excessive pressure may cause flow to be dumped over the relief valve, and create a lube system fault.

Table 2. Approximate SSU Oil Viscosities for SAE Numbering System at Various Temperatures (°F)

	50 °	60 °	70 °	80 °	100 °	210 °
SAE 70	17,000	10,000	6,500	4,000	1,850	130
SAE 60	11,500	7,000	4,500	3,000	1,400	110
SAE 50	8,500	4,600	3,000	2,000	985	90
SAE 40	4,700	3,000	1,900	1,350	680	75
SAE 30	3,100	2,000	1,350	950	490	65
SAE 20	2,000	1,300	900	650	350	57
SAE 10	850	600	420	310	185	46

Filter Pressure Drop

If a filter is specified, its pressure drop is considered part of the system pressure since it is downstream of the relief valve. The pressure drops for filters with a clean element can be found in Figure 6.

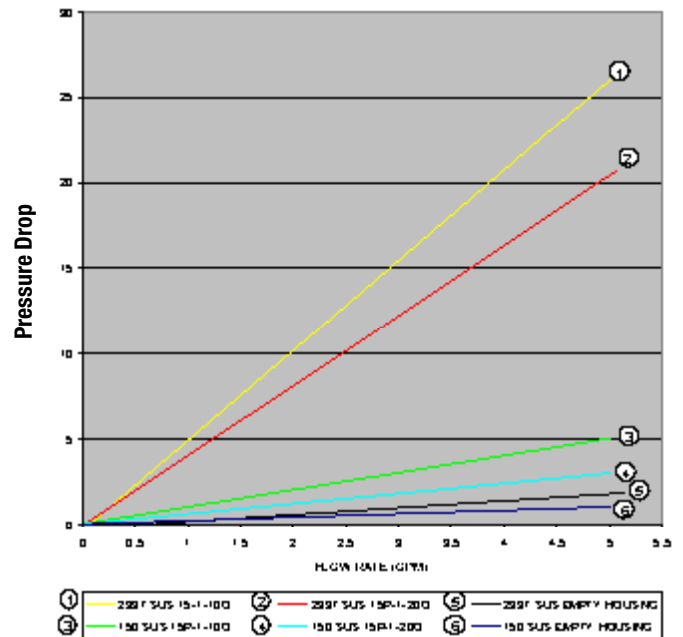

Figure 6. Flow vs. Pressure Loss of Meterflo Filters with Clean Element

SPECIFICATIONS	
Pump/Motor Assembly	
Motor Voltage	
MOA	115/230 VAC, 60 Hz, 1 PH
MOB	230/460 VAC, 60 Hz, 3 PH
Motor Power (max)	1/2 HP
Pump Displacement	See How To Order (pump output is virtually consistent from 500 to 1500 psi for viscosities between 300 and 3000 SUS. See Bulletin L12611)
Pump Pressure Rating (internal relief)	1200 psi
External Relief Valve	1000 psi
Noise Rating (nominal)	65-68 dbA
Suction Strainer	140 micron stainless steel mesh
Pressure Gauge	0-1500 psi
Elec. Conn. (CMA/C)	Barrier Strip Inside Controller
Reservoir Assembly	
Volume	
RAA/C	15 gallon
RAB/D	30 gallon
Reservoir Materials	
Tank	Painted Steel
Level Gauge	Clear Nylon
Filler/Breather	Stainless Steel
Low Level Switch Part No. 557826 (541-603-002)	
Contacts	N.O.
Max Contact Rating (resistive load) @ 24 VDC	0.3 amps

Options	
High Level Switch Part No. 557825 (541-603-001)	
Contacts	N.O.
Max Contact Rating (resistive load) @ 24 VDC	0.3 amps
Pressure Switch Part No. Dis. (507-509-000)	
Actuator	Diaphragm
Adjustment Range	125 to 1500 psi
Contacts	N.O. and N.C.
Contact Rating (inductive load)	10A @ 125/250 VAC, 0.5A @ 30 VDC
Pressure Filters (See Bulletin L15200)	
FOG/FOH	10 micron
FOJ/FOK	20 micron
Controllers	
CMA (Maxi-Monitor) 115/230 VAC	See Bulletin L14750
CMC (Lube Sentinel II) 115 VAC	See Bulletin L14701
CMD (Lube Sentinel II) 230 VAC, 1 PH	See Bulletin L14701

MAINTENANCE INFORMATION

Normally, the only maintenance required on Meterflo packages is filling the reservoir, and cleaning the suction strainer. Use only fresh, uncontaminated oil to fill the reservoir. Check the suction strainer annually, or more often if the pump is becoming noisy (cavitating) between cleaning. The suction strainer is accessed by removing the reservoir cover.

It is also a good idea to periodically verify pump operation (lube delivery), the calibration of the timer settings and pressure switch setting, and the actuation depth of the low level switch, if these options are used.

RELIEF SETTINGS

The Pressure Switch option can be used to activate an alarm when pressure at the pump outlet exceeds a preset valve. The switch setting is adjustable over a range of 125 to 1,500 psi.

CAUTION

The system relief valve is set at 1,000 psi by Graco. Always keep this setting at least 200 psi below the internal pump relief setting, which is factory set at 1,200 psi. This prevents flow from being dumped over the internal pump relief. Do not attempt to adjust the internal relief above 1,500 psi as this will result in pump damage.

Setting System Relief Pressure

Loosen the tube connections at the relief valve and at the tank check valve. Remove the tube. Loosen and remove the relief valve locknut with the tube fitting body (see Figure 7). Use a 7/32" allen wrench to adjust the relief valve by turning the spring retainer. Turn the retainer clockwise to increase pressure or counterclockwise to decrease pressure. Install and tighten the relief valve locknut and all connecting tube assemblies.

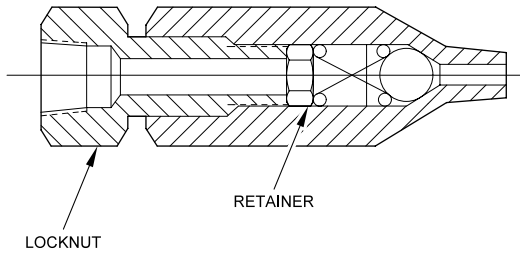

Figure 7. Relief Valve Adjustment

Setting Internal Pump Relief

To gain access to the adjustment screw, remove the relief valve adjustment cap (located on the suction side of the pump (see Figure 8)). Turn the adjustment screw clockwise to increase pressure or counterclockwise to decrease pressure. Replace and tighten the adjustment screw cap.

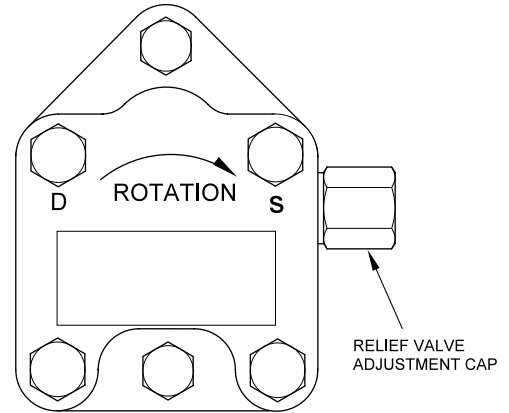
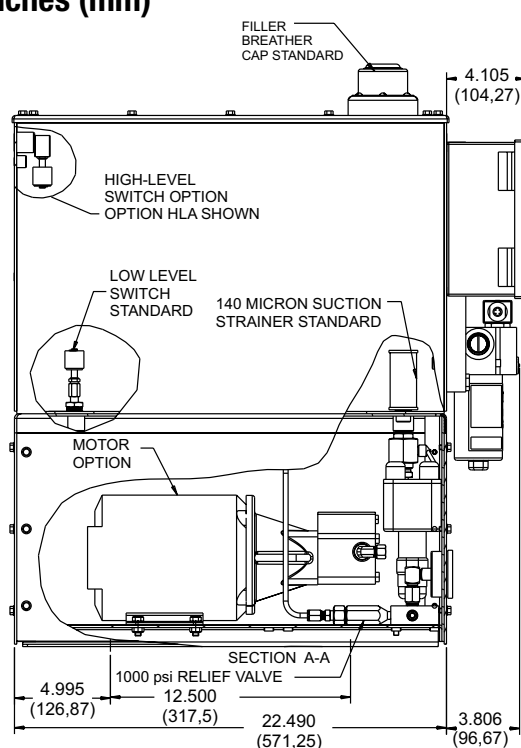

Figure 8. Internal Pump Relief

INSTALLATION DIMENSIONS

Inches (mm)



RESERVOIR	SIZE "A"
15 GAL.	27.375
30 GAL.	33.875

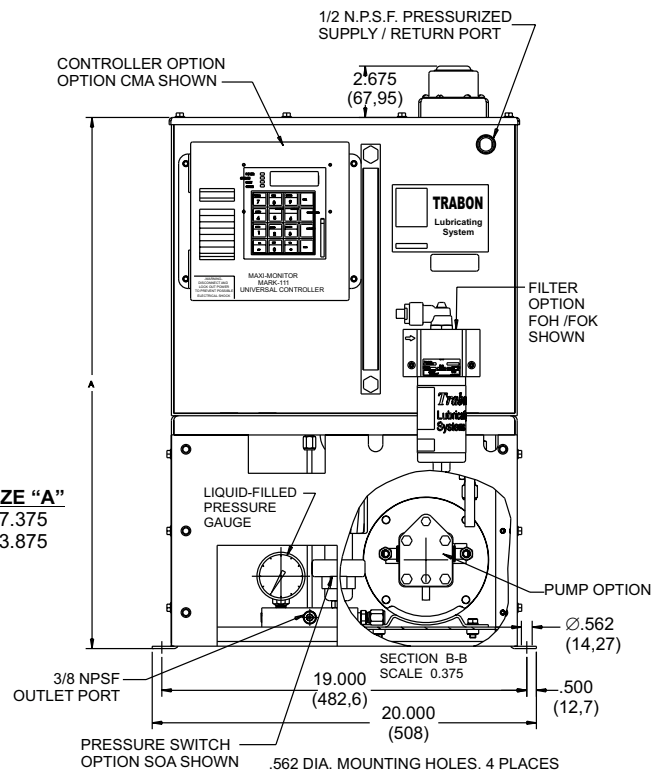

HOW TO ORDER

RTP - XXX - XXX - XXX - XXX - XXX - XXX - XXX - XXX

RESERVOIR OPTION

RAA - 15 GALLON
 RAB - 30 GALLON
 RAC - 15 GALLON LESS SIDE COVERS
 RAD - 30 GALLON LESS SIDE COVERS

PUMP OPTION

POA - 14 IN³/MIN @ 1725 RPM, 557814 (540-800-011), CCW
 POB - 30 IN³/MIN @ 1725 RPM, 557813 (540-800-001), CCW
 POC - 40 IN³/MIN @ 1725 RPM, 557818 (540-800-091), CCW
 POD - 84 IN³/MIN @ 1725 RPM, 557815 (540-800-021), CCW
 POE - 117 IN³/MIN @ 1725 RPM, 557816 (540-800-041), CCW
 POF - 168 IN³/MIN @ 1725 RPM, 557817 (540-800-061), CCW
 POG - 245 IN³/MIN @ 1725 RPM, 557820 (540-800-111), CCW

MOTOR OPTION

MOA - 1/2 HP, 115/230 VAC, 1725 RPM, 1 PH, 558895 (492-460-210)
 MOB - 1/2 HP, 230/460 VAC, 1725 RPM, 3 PH, DISCONTINUED (492-460-230)
 M99 - SPECIAL

RESERVOIR FILL FILTER OPTION

RFO - NO FILTER
 RFA - 10 MICRON FILTER W/GAUGE AND AUTO RELIEF VALVE, 563095 (473-000-271), 3/4 NPT FEMALE

PRESSURE SWITCH OPTION

SOO - NO PRESSURE SWITCH
 SOA - 800 PSI PRESSURE SWITCH, DISCONTINUED (507-509-000)

PRESSURE FILTER OPTION

FOO - NO FILTER
 FOG - 10 MICRON FILTER W/VISUAL INDICATOR, 562882 (183-100-010), SAE, ISO 11926 PORTS
 FOH - 10 MICRON FILTER W/ELECTRICAL/VISUAL INDICATORS, 562880 (183-100-004), SAE, ISO 11926 PORTS
 FOJ - 20 MICRON FILTER W/VISUAL INDICATOR, 562883 (183-100-011), SAE, ISO 11926 PORTS
 FOK - 20 MICRON FILTER W/ELECTRICAL/VISUAL INDICATORS, 564007 (183-100-005), SAE, ISO 11926 PORTS

HIGH LEVEL SWITCH OPTION

HLO - NO HIGH LEVEL SWITCH
 HLA - HIGH LEVEL SWITCH, 557825 (541-603-001)

CONTROLLER OPTION

COM - NO CONTROLLER
 CMA - 115 VAC MAXI-MOTOR W/MOTOR STARTER
 CMC - 115 VAC LUBE SENTINEL W/O MOTOR STARTER, 562870 (162-300-690)
 CMD - 230 VAC, 1 PH, LUBE SENTINEL II W/O MOTOR STARTER, (162-300-691)

COMPONENT ORDERING		
Description	Part No.	Old Part No.
Maxi-Monitor only		
115 VAC	556023	163-310-000
230 VAC	556024	163-310-010
Lube Sentinel II, 115 VAC	562870	162-300-690
Lube Sentinel II, 230 VAC, 1 pH	-	162-300-691
Adj. Relief Valve, Factory set @ 1200 psi	563556	540-375-001
Low Level Switch	557826	541-603-002
High Level Switch	557825	541-603-001
Pressure Switch, 125-1400 psi	Dis	507-509-000

Description	Part No.	Old Part No.
Suction Strainer, 140 micron	557133	473-000-240
Pump Mounting Bracket, C Face, w/ Drive Coupling	558956	540-835-000
Pressure Filter - Replacement & Elements		
10 micron	556031	183-100-105
20 micron	556032	183-100-106
Reservoir Fill Filter Replacement, 10 micron	563093	473-000-262

All written and visual data contained in this document are based on the latest product information available at the time of publication. Graco reserves the right to make changes at any time without notice.

Contact us today!

To receive product information or talk with a Graco representative, call 800-533-9655 or visit us online at www.graco.com.

