

# IB IL 24 DI 4(-2MBD)-PAC

Inline digital input terminal, 4 inputs, 24 V DC

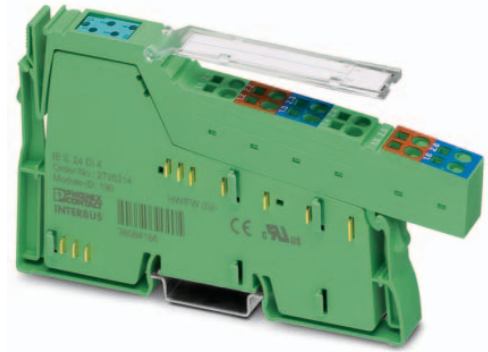

Data sheet  
5550\_en\_06

© PHOENIX CONTACT 2015-04-07

## 1 Description

The terminal block has been developed for use in an Inline station. It is used to acquire digital signals.

### Features

- Connections for four digital sensors
- Connection of 2 or 3-wire sensors
- Maximum permissible load current per sensor: 250 mA
- Maximum permissible load current from the terminal: 1 A
- Diagnostic and status indicators

### IB IL 24 DI 4-PAC

- Permissible for use in potentially explosive areas



**WARNING: Explosion hazard when used in potentially explosive areas**

When using the terminal in potentially explosive areas, observe the corresponding notes.



This data sheet is only valid in association with the IL SYS INST UM E user manual.



Make sure you always use the latest documentation.  
It can be downloaded from the product at [phoenixcontact.net/products](http://phoenixcontact.net/products).

<b>2</b>	<b>Table of contents</b>	
1	Description .....	1
2	Table of contents .....	2
3	Ordering data .....	3
4	Technical data .....	4
5	Additional tables .....	6
	5.1 Input characteristic curve .....	6
	5.2 Power dissipation .....	6
	5.3 Limitation of simultaneity, derating .....	7
6	Internal circuit diagram .....	7
7	Local status and diagnostic indicators .....	8
8	Terminal point assignment.....	8
9	Connection notes and examples .....	9
10	Notes on using the terminal block in potentially explosive areas .....	10
11	Process data.....	11

### 3 Ordering data

Description	Type	Order No.	Pcs. / Pkt.
Inline digital input terminal, complete with accessories (connector plug and labeling field), 4 inputs, 24 V DC, 3-wire connection technology	IB IL 24 DI 4-PAC	2861234	1
Inline digital input terminal block, complete with accessories (connector and labeling field), 4 inputs, 24 V DC, 3-wire connection method	IB IL 24 DI 4-2MBD-PAC	2692306	1
Accessories	Type	Order No.	Pcs. / Pkt.
Labeling field, width: 12.2 mm (Marking)	IB IL FIELD 2	2727501	10
Insert strip, Sheet, white, unlabeled, can be labeled with: Office printing systems, Plotter: Laser printer, Mounting type: Insert, Lettering field: 62 x 10 mm (Marking)	ESL 62X10	0809492	1
Connector, for digital 1, 2 or 8-channel Inline terminals (Connector/Adapter)	IB IL SCN-8	2726337	10
Inline connector, colored (Connector/Adapter)	IB IL SCN-8-CP	2727608	10
Zack marker strip, Strip, white, unlabeled, can be labeled with: Plotter, Mounting type: Snap into tall marker groove, for terminal block width: 6.2 mm, Lettering field: 6.15 x 10.5 mm (Marking)	ZB 6:UNBEDRUCKT	1051003	10
Zack marker strip, Strip, white, unlabeled, can be labeled with: Plotter, Mounting type: Snap into tall marker groove, for terminal block width: 6.2 mm, Lettering field: 6.15 x 10.5 mm (Marking)	ZB 6/WH:UNBEDRUCKT	5060935	100
Zack marker strip, Strip, white, labeled, can be labeled with: Plotter, Printed vertically: Consecutive numbers 1 - 10, 11 - 20, etc. up to 491 - 500, Mounting type: Snap into tall marker groove, for terminal block width: 6.2 mm, Lettering field: 6.15 x 10.5 mm (Marking)	ZB 6,QR:FORTL.ZAHLEN	1051029	10
Zack marker strip, white, Printed vertically: Identical numbers 1 or 2, etc. up to 1000, for terminal block width: 6 mm (Marking)	ZB 6,QR:GLEICHE ZAHLEN	1051045	10
Zack marker strip, white, for terminal block width: 6 mm (Marking)	ZB 6:SO/CMS	1050499	10
Flat zack marker sheet, Sheet, white, unlabeled, can be labeled with: Plotter, Mounting type: Snap into flat marker groove, for terminal block width: 6.2 mm, Lettering field: 5 x 5.5 mm (Marking)	ZBFM 6/WH:UNBEDRUCKT	0803618	10
Flat zack marker sheet, orange, unlabeled, for terminal block width: 6.2 mm (Marking)	ZBFM 6/OG:UNBEDRUCKT	0807193	10
Flat zack marker sheet, white, for terminal block width: 6.2 mm (Marking)	ZBFM 6:SO/CMS	0803650	1
Marker pen, for manual labeling of unprinted Zack strips, smear-proof and waterproof, line thickness 0.5 mm (Marking)	B-STIFT	1051993	10
Marker pen without ink cartridge, for manual labeling of markers, labeling extremely wipe-proof, line thickness 0.35 mm (Marking)	X-PEN 0,35	0811228	1
Documentation	Type	Order No.	Pcs. / Pkt.
User manual, English, Automation terminals of the Inline product range	IL SYS INST UM E	-	-
Data sheet, English, INTERBUS addressing	DB GB IBS SYS ADDRESS	-	-

## 4 Technical data

### Dimensions (nominal sizes in mm)

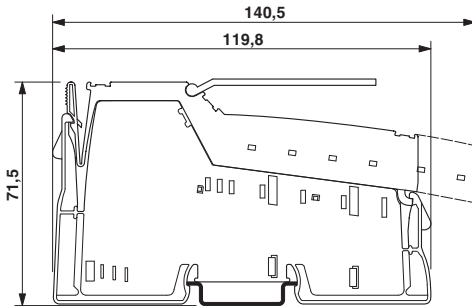

Width	12.2 mm
Height	140.5 mm
Depth	71.5 mm
Note on dimensions	Housing dimensions

### General data

Color	green
Weight	66 g (with connector)
Operating mode	Process data operation with 4 bits
Ambient temperature (operation)	-25 °C ... 55 °C
Ambient temperature (storage/transport)	-25 °C ... 85 °C
Permissible humidity (operation)	10 % ... 95 % (according to DIN EN 61131-2)
Permissible humidity (storage/transport)	10 % ... 95 % (according to DIN EN 61131-2)
Air pressure (operation)	70 kPa ... 106 kPa (up to 3000 m above sea level)
Air pressure (storage/transport)	70 kPa ... 106 kPa (up to 3000 m above sea level)
Degree of protection	IP20
Protection class	III, IEC 61140, EN 61140, VDE 0140-1

### Connection data

Designation	Inline connector
Connection method	Spring-cage connection
Conductor cross section solid / stranded	0.08 mm <sup>2</sup> ... 1.5 mm <sup>2</sup> / 0.08 mm <sup>2</sup> ... 1.5 mm <sup>2</sup>
Conductor cross section [AWG]	28 ... 16
Stripping length	8 mm

### Connection data for UL approvals

Designation	Inline connector
Connection method	Spring-cage connection
Conductor cross section solid / stranded	0.2 mm <sup>2</sup> ... 1.5 mm <sup>2</sup> / 0.2 mm <sup>2</sup> ... 1.5 mm <sup>2</sup>
Conductor cross section [AWG]	24 ... 16
Stripping length	8 mm

### Interface Inline local bus

Connection method	Inline data jumper
-------------------	--------------------

**Transmission speed Inline local bus**

IB IL 24 DI 4-PAC	500 kBit/s
IB IL 24 DI 4-2MBD-PAC	2 MBit/s

**Power consumption ( 500 kBit/s )**

Main circuit supply $U_M$	24 V DC
Current consumption from $U_M$	max. 8 A DC
Segment supply voltage $U_S$	24 V DC (nominal value)
Current consumption from $U_S$	max. 1 A
Communications power $U_L$	7.5 V DC (via voltage jumper)
Current consumption from $U_L$	max. 40 mA
Power consumption	max. 0.3 W (at $U_L$ )

**Power consumption ( 2 MBit/s )**

Main circuit supply $U_M$	24 V DC
Current consumption from $U_M$	max. 8 A DC
Segment supply voltage $U_S$	24 V DC (nominal value)
Current consumption from $U_S$	max. 1 A
Communications power $U_L$	7.5 V DC (via voltage jumper)
Current consumption from $U_L$	max. 51 mA
Power consumption	max. 0.4 W (at $U_L$ )

**Digital inputs**

Number of inputs	4 (EN 61131-2 type 1)
Connection method	Spring-cage connection
Connection method	2, 3-wire
Nominal input voltage	24 V DC
Input voltage	24 V DC (via voltage jumper)
Input voltage range	-30 V DC ... 30 V DC
Nominal input current	min. 3 mA (at nominal voltage)
Input voltage range "0" signal	-3 V DC ... 5 V DC
Input voltage range "1" signal	15 V DC ... 30 V DC
Permissible conductor length to the sensor	30 m
Use of AC sensors	AC sensors in the voltage range $< U_{IN}$ are limited in application (according to the input design)
Short-circuit and overload protection	Yes

**Programming data (INTERBUS, local bus)**

ID code (hex)	BE
ID code (dec.)	190
Length code (hex)	41
Length code (dec.)	65
Process data channel	4 Bit
Input address area	4 Bit
Output address area	0 Bit
Parameter channel (PCP)	0 Bit
Register length (bus)	4 Bit



For the programming data/configuration data of other bus systems, please refer to the corresponding electronic device data sheet (e.g., GSD, EDS).

**Configuration and parameter data in a PROFIBUS system**

Required parameter data	1 Byte
Need for configuration data	4 Byte

**Error messages to the higher level control or computer system**

None

**Electrical isolation/isolation of the voltage areas**

Test section	Test voltage
5 V supply, incoming remote bus/7.5 V supply (bus logics)	500 V AC, 50 Hz, 1 min
5 V supply, outgoing remote bus/7.5 V supply (bus logics)	500 V AC, 50 Hz, 1 min
7.5 V supply (bus logics)/24 V supply (I/O)	500 V AC, 50 Hz, 1 min
24 V supply (I/O) / functional earth ground	500 V AC, 50 Hz, 1 min



To achieve electrical isolation between the logic level and the I/O area, supply these areas from separate power supply units. Interconnection of the power supply units in the 24 V area is not permitted (see also user manual).

**Approvals**

For the latest approvals, please visit [phoenixcontact.net/products](http://phoenixcontact.net/products).

**5 Additional tables**

**5.1 Input characteristic curve**

500 kbps

**Current depending on the input voltage and the ambient temperature  $T_A$**

Supply voltage [V]	Input current [mA]	Input current for $t \geq 20$ s [mA]	
		$T_A = 25^\circ\text{C}$	$T_A = 55^\circ\text{C}$
18	3.0	2.9	2.5
24	3.9	3.8	3.5
30	4.5	4.2	3.0

The current is reduced depending on the ambient temperature and the number of inputs that are switched on (internal module temperature).

**5.2 Power dissipation**

**Formula for calculating the power dissipation of the electronics**

$$P_{EL} = 0,24 \text{ W} + \sum_{i=1}^n (U_{INi} \times 0,003 \text{ A})$$

Where:

- $P_{EL}$  Total power dissipation in the terminal
- $i$  Continuous index
- $n$  Number of set inputs ( $n = 1 \dots 4$ )
- $U_{INi}$  Input voltage of input  $i$

**Power dissipation of the housing**

Maximum 0.6 W (within the permissible operating temperature)

5.3 Limitation of simultaneity, derating

500 kbps

No limitation of simultaneity, no derating

2 Mbps

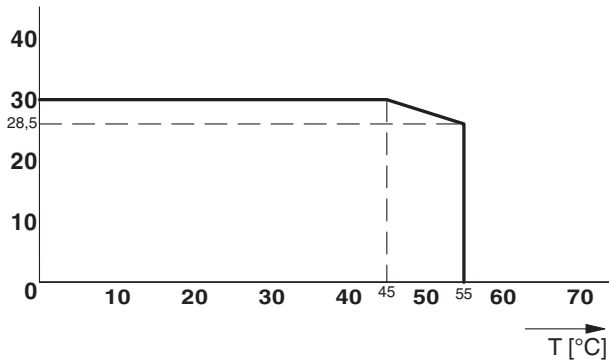

Figure 1 Derating diagram

6 Internal circuit diagram

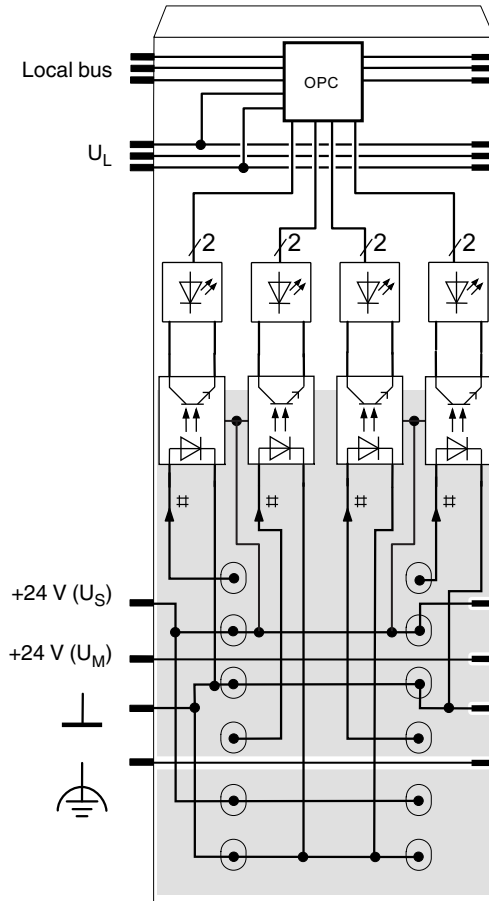







Figure 2 Internal wiring of the terminal points

Key:

-  Protocol chip (Bus logic including voltage conditioning)
-  LED (status indicator)
-  Optocoupler
-  Digital input
-  Electrically isolated area

 Explanation for other used symbols has been provided in the IL SYS INST UM E user manual.

## 7 Local status and diagnostic indicators

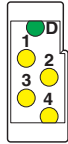

Figure 3 Local status and diagnostic indicators

Designation	Color	Meaning
D	Green	Diagnostics (bus and logic voltage)
1 ... 4	Yellow	Status of the inputs

### Function identification

Light blue

2 Mbps: White stripe in the vicinity of the D LED

## 8 Terminal point assignment

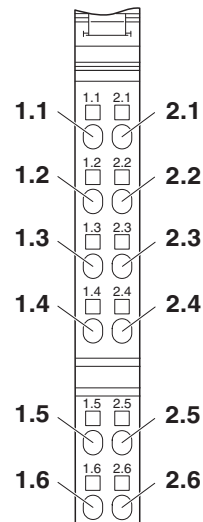

Figure 4 Terminal point assignment

Terminal point	Assignment
1.1 / 2.1	Signal input (IN 1 / IN 2)
1.2 / 2.2	Segment voltage $U_S$ for 2 and 3-wire connection
1.3 / 2.3	Ground contact (GND) for 3-wire connection
1.4 / 2.4	Signal input (IN 3 / IN 4)
1.5 / 2.5	Segment voltage $U_S$ for 2 and 3-wire connection
1.6 / 2.6	Ground contact (GND) for 3-wire connection



## 9 Connection notes and examples



**NOTE: Malfunction**

Make sure that the supply voltage  $U_S$  is available, as it is used internally as the auxiliary voltage.



When connecting the sensors observe the assignment of the terminal points to the process data.

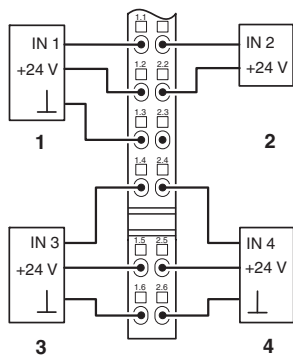

Figure 5 Typical connection of sensors

- 1, 3, 4 3-wire connection
- 2 2-wire connection

## 10 Notes on using the terminal block in potentially explosive areas

Valid for: IB IL 24 DI 4-PAC

Approval according to EC directive 94/9/EC

Ⓢ II 3 G EEx nAC IIC T4 U



### WARNING: Explosion hazard

Please make sure that the following notes and instructions are observed.

### Installation notes

1. This Inline terminal is a category 3 device and is suitable for installation in the potentially explosive areas of zone 2.
2. The Inline terminal must only be installed, operated, and maintained by qualified personnel.
3. Please follow the installation instructions given in the IL SYS INST UM E user manual and the package slip.
4. When installing and operating the device, the applicable safety directives (including national safety directives), accident prevention regulations, as well as general technical regulations, must be observed.
5. For the safety data, please refer to the corresponding documentation (user manual, data sheet, package slip) and the certificates (declaration of conformity and other approvals, if applicable).
6. Access to the circuits inside the Inline terminal is not permitted. Do not repair the Inline terminal by yourself but replace it with a terminal of the same type. Repairs may only be performed by the manufacturer. The manufacturer is not liable for damage resulting from noncompliance.
7. The IP20 degree of protection (EN 60529) of the device is intended for a clean and dry environment.
8. Do not subject the Inline terminal to mechanical strain and/or thermal loads, which exceed the limits specified in the product documentation.
9. The Inline terminal is not designed for use in atmospheres with a danger of dust explosions. If dust is present, install the device in suitable, approved housing. Please note the surface temperature of the housing.

### Installation in zone 2

1. Observe the specified conditions for use in potentially explosive areas.
2. Install the device in a suitable approved housing (with at least IP54 degree of protection) that meets the requirements of EN 60079-15. Observe the requirements of EN 60079-14.
3. In potentially explosive areas, only snap the device onto the DIN rail and remove it from the DIN rail and connect and disconnect the cables when the power is disconnected.
4. Connect the DIN rail to the protective earth ground.
5. In zone 2, only connect devices to the supply and signal circuits that are suitable for operation in potentially explosive areas of zone 2 and the conditions at the installation location.

### Restrictions/limit values

1. **Only Inline terminals that are approved for use in potentially explosive areas may be assembled on this Inline terminal.**  
Before using an Inline terminal in a zone 2 potentially explosive area, check whether it has been approved for installation within this area.  
For a list of terminals that are approved for the potentially explosive areas of zone 2, please refer to the AH EN IL EX ZONE 2 application note.
2. Please make sure that the **maximum permissible current of 4 A** flowing through potential jumpers  $U_M$  and  $U_S$  (total current) is not exceeded when using the Inline terminals in potentially explosive areas.
3. Also ensure that the **maximum permissible current of 2 A** flowing through potential jumper  $U_L$  is not exceeded.
4. The maximum permissible current for each tension spring contact is 2 A.

## 11 Process data

### Assignment of the terminal points to the output process data

(Byte.Bit) view	Byte.Bit	0.3	0.2	0.1	0.0
Assignment	Terminal point (signal)	2.4	1.4	2.1	1.1
	Terminal point (24 V)	2.5	1.5	2.2	1.2
	Terminal point (GND)	2.6	1.6	2.3	1.3
Status indicator	LED	4	3	2	1



For the assignment of the illustrated (byte.bit) view to your INTERBUS control or computer system, please refer to the DB GB IBS SYS ADDRESS data sheet.