

Technical Features

- › Screw-in cartridge 3-way pressure compensator, spool-type
- › High flow capacity
- › The valve maintains a constant pressure drop on a flow control valve (e.g. proportional directional control valve) and thus a constant volumetric flow independent of actuator load
- › Rapid and smooth response to load changes
- › Stable function throughout the whole flow range
- › Precisely manufactured and hardened key parts
- › Pressure drop setting by adjusting screw in the range from 5 to 40 bar (72.5 – 580 PSI)
- › In the standard version, the valve surface is zinc-coated for corrosion protection 240 h in NSS acc. to ISO 9227

Functional Description

The 3-way pressure compensator maintains a constant pressure drop on the flow control valve and thus a constant volumetric flow independent of actuator load changes or pump power fluctuation. The spool position of the compensator is controlled by pressure drop sensed upstream (B) and downstream (X) from the valve. The set pressure drop is defined by spring pressure acting on the spool face and is maintained by releasing excess flow back to the tank. In the basic position the compensator is closed. The volumetric flow, and thus the moving velocity of piston rod or hydraulic motor shaft can be regulated by change of flow cross section on the flow control valve or by change the set pressure drop on the pressure compensator with the adjusting screw.

The three-way pressure compensator is connected parallel to the flow control valve. It maintains a constant pressure drop on the valve by dividing the flow from the pump. When the actuator is stopped, the pressure compensator opens and allows full fluid flow from the pump to the tank at low pressure losses. It takes over the function of unloading valve and protects the circuit against overheating. The three-way pressure compensator is very often used for system pressure regulation depending on the load (LS-regulation) in the circuits with a constant displacement pump.

Technical Data

Valve size / Cartridge cavity		M20x1.5 / QE3
Max. operating pressure	bar (PSI)	350 (5080)
Max. flow	l/min (GPM)	40 (10.6)
Control pressure differential	bar (PSI)	5 ... 40 (72.5 ... 580)
Fluid temperature range (NBR)	°C (°F)	-30 ... +100 (-22 ... +212)
Fluid temperature range (FPM)	°C (°F)	-20 ... +120 (-4 ... +248)
Weight	kg (lbs)	0.15 (0.3)

		Data Sheet	Type
General information		GI_0060	Products and operating conditions
Valve bodies	Sandwich mounted	SB-04(06)_0028	SB-*QE3*
Cavity details		SMT_0019	SMT-QE3*
Spare parts		SP_8010	

Characteristics measured at $v = 32 \text{ mm}^2/\text{s}$ (156 SUS)

Regulated flow related to input pressure

The characteristic of the pressure compensator corresponds with the flow rate of a PRM2-043Z11/12 and PRM2-063Z11/30 proportional directional valve.

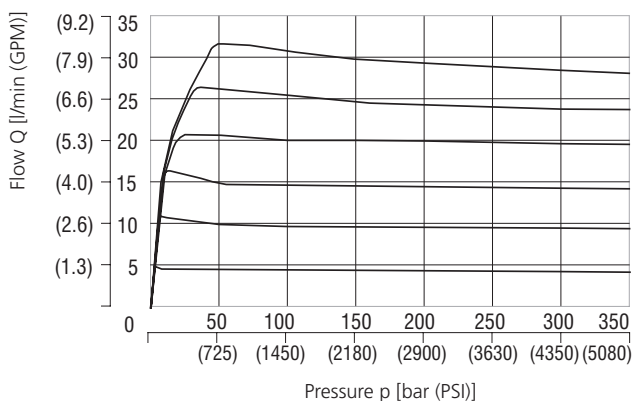

If the pressure resistance increases due to a flow rate increase, the pressure differential also has to increase in order to ensure correct regulation.

Dimensions in millimeters (inches)

TV3-063/S

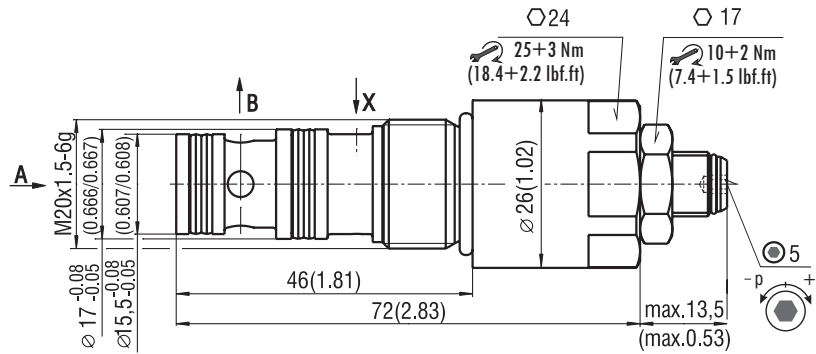

Application Example

Example: connection of three-way pressure compensator

Hydraulic circuit with continuous regulation of volumetric flow and speed of hydraulic motor (HM), independent of load torque acting on the HM shaft. The three-way pressure compensator, connected parallel to the valve, maintains a constant pressure drop on the proportional flow control valve by discharging the excess fluid from pump (from P-channel) to the tank (T-channel).

The proportional pressure valve is used for continuous setting of the pressure compensator.

When HM is stopped, working fluid will drain through the pressure compensator to the tank at a low pressure drop.

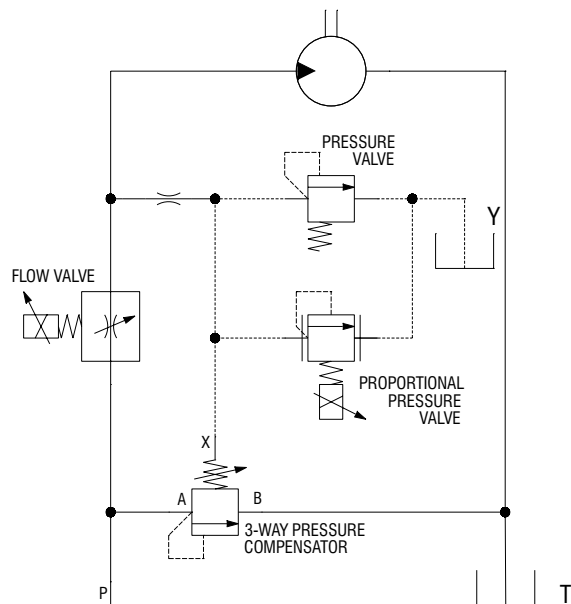

Ordering Code

TV3-063/S 4 S	
3-Way pressure compensator, spool-type, direct-acting	
Nominal size 06 M20x1.5 / QE3	
3-Way pressure compensator	
Cartridge design	
Pressure range 5 - 40 bar (72.5 - 580 PSI)	
A	Surface treatment zinc-coated (ZnCr-3), ISO 9227 (240 h)
B	zinc-coated (ZnNi), ISO 9227 (520 h)
No designation	Seals NBR FPM (Viton)
V	Adjustment option allen key (hex. 5)