

Preparation of compressed air → Supplementary products

Distributor, Series NL2-DIL

► G 1/4 ► Distributor 4x ► Narrow distributor



00106918

Version	Narrow distributor, Can be assembled into blocks
Mounting orientation	Any
Working pressure min./max.	0 bar / 16 bar
Medium	Compressed air
Medium temperature min./max.	-10°C / +60°C
Ambient temperature min./max.	-10°C / +60°C
Materials:	
Housing	Die cast zinc
Front plate	Acrylonitrile butadiene styrene

Technical Remarks

- Suitable for direct mounting of a PE1 and PM1 series pressure sensor (flange version)

	Port	Qn					Weight	Part No.
		1►2	1►3	1►4	1►5	1►6		
		[l/min]						
	G 1/4	2700	2700	900	2000	900	0.25	0821300920

nominal flow Qn with secondary pressure 6 bar at $\Delta p = 1$ bar

Supplementary products

Part numbers marked in bold are available from the central warehouse in Germany, see the shopping basket for more detailed information Pneumatics catalog, online PDF, as of 2013-06-22, © Bosch Rexroth Pneumatics GmbH, subject to change

Preparation of compressed air → Supplementary products

Distributor, Series NL2-DIL

► G 1/4 ► Distributor 4x ► Narrow distributor

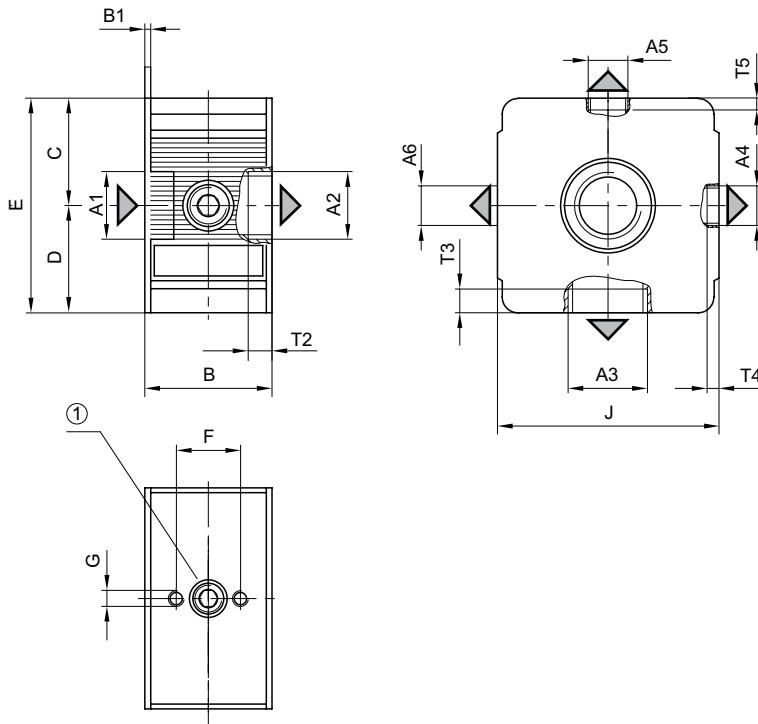
Dimensions

00107308

1) hole pattern for mechanical vacuum/pressure switch

A1	A2	A3	A4	A5	A6	B	B1	C	D	E	F	G	J
G 1/4	G 1/4	G 1/4	G 1/4	G 1/8	G 1/4	35	1.5	26	26	52	20	M5	47
A1	T2	T3	T4	T5									
G 1/4	12	8.5	7	8									

Supplementary products

Part numbers marked in bold are available from the central warehouse in Germany, see the shopping basket for more detailed information
 Pneumatics catalog, online PDF, as of 2013-06-22, © Bosch Rexroth Pneumatics GmbH, subject to change