







Pressure Switches, Series PM1

- Operating pressure -0,9 ... 0, -0,9 ... 3, 0,2 ... 16 bar
- mechanical
- Spring-loaded bellow, adjustable
- Electr. connection Plug, ISO 4400, form A
- Compressed air connection Internal thread, G 1/4, Flange with O-ring, Ø 5x1,5



Type	mechanical
Function	change-over contact (mechanical)
Mounting orientation	Any
Working pressure min./max.	See table below
Ambient temperature min./max.	-20 ... 80 °C
Medium temperature min./max.	-10 ... 80 °C
Medium	Compressed air, hydraulic oil
Measurement	Relative pressure
Switching element	microswitch (input/output)
Protection against overpressure	80 bar
Max. switching frequency	1,5 Hz
Shock resistance max.	15 g
Vibration resistance	10 g (60 - 500 Hz)
Repeatability (% of full scale value)	± 1 %
Switching point	adjustable
Hysteresis	max. switching pressure difference
DC operating voltage,min./max.	12 ... 30 V DC
Operational voltage AC,min./max.	12 ... 250 V AC
Mounting types	via through holes
Protection class	IP65
Electr. connection	Plug, ISO 4400, form A
Weight	0,16 kg

Technical data

Part No.		Type	Operating pressure range	Compressed air connection	Scope of delivery	Fig.
			min./max.			
R412010711		PM1-M3-G014	-0,9 ... 0 bar	Internal thread, G 1/4	With valve plug connector	Fig. 1
R412022752		PM1-M3-G014	-0,9 ... 3 bar	Internal thread, G 1/4	Without valve plug connector	Fig. 1
R412010712		PM1-M3-G014	0,2 ... 16 bar	Internal thread, G 1/4	Without valve plug connector	Fig. 1
R412010713		PM1-M3-G014	0,2 ... 16 bar	Internal thread, G 1/4	With valve plug connector	Fig. 1
R412010714		PM1-M3-F001	-0,9 ... 0 bar	Flange with O-ring, Ø 5x1,5	With valve plug connector	Fig. 2
R412010715		PM1-M3-F001	0,2 ... 16 bar	Flange with O-ring, Ø 5x1,5	Without valve plug connector	Fig. 2
R412010718		PM1-M3-F001	0,2 ... 16 bar	Flange with O-ring, Ø 5x1,5	With valve plug connector	Fig. 2

Part No.	
R412010711	-
R412022752	-
R412010712	1)
R412010713	1)
R412010714	-

Part No.	
R412010715	1)
R412010718	1)

1) Min. switching pressure range 0.2 bar falling/0.5 bar rising

Technical information

Switching function increasing pressure: contact switches from 1-2 to 1-3. Switching function decreasing pressure: contact switches from 1-3 to 1-2.

Notice: Too-high currents can damage contacts. Inductive or capacitive loads must be equipped with appropriate spark-quenching!

The microswitch has silver-plated contacts.

Please observe the pin assignment when selecting plug connectors.

Technical information

Material	
Housing	Aluminum
Seals	Acrylonitrile butadiene rubber
Electr. connection	Brass, nickel-plated

Dimensions

Fig. 1

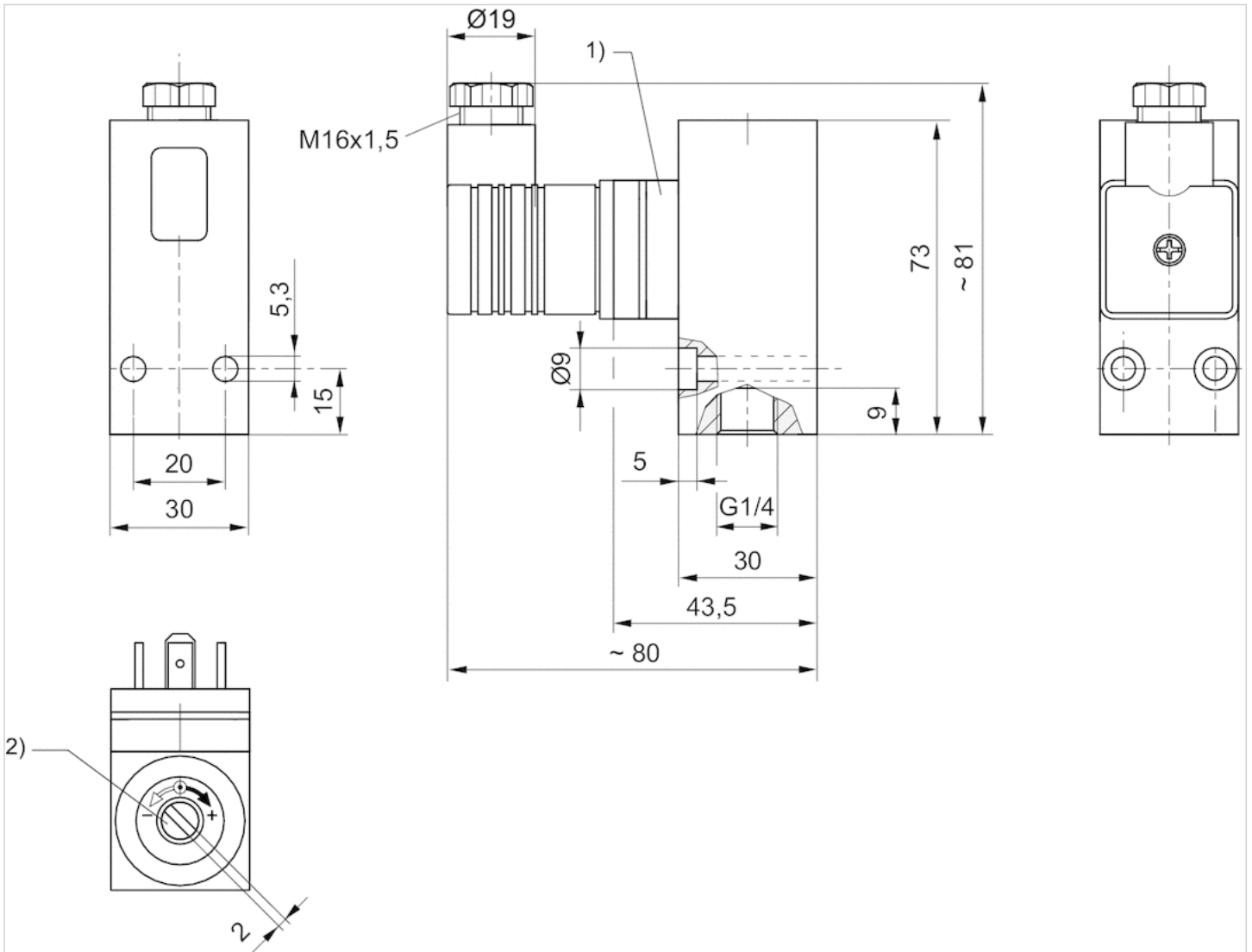

- 1) Valve plug connector
- 2) Adjustment screw, self-holding

Fig. 2

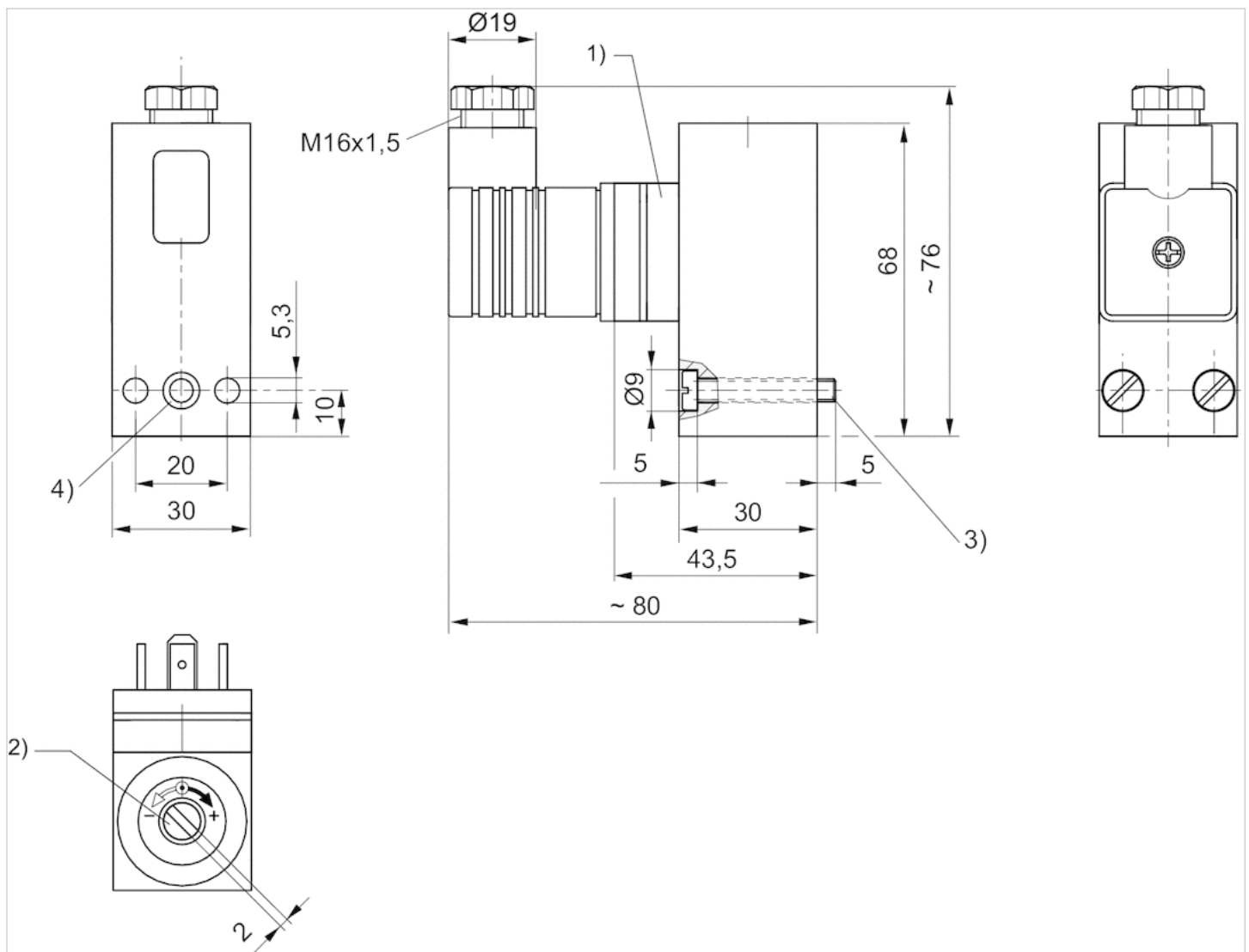

- 1) Valve plug connector
- 2) Adjustment screw, self-holding
- 3) cylinder screw M5x30 (included in scope of delivery)
- 4) O-ring Ø5x1,5 (included)

Diagrams

differential switching pressure characteristic curve (-09 - 0 bar)

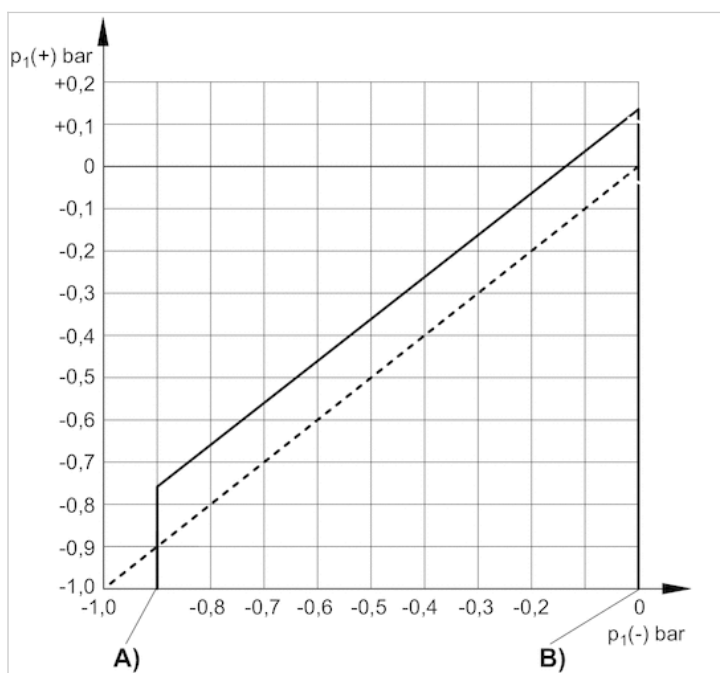
A) $p_1(-)$, min.B) $p_1(-)$, max. $p_1(+)$ = upper switching pressure with increasing pressure $p_1(-)$ = lower switching pressure with decreasing pressure

differential switching pressure characteristic curve (02 - 16 bar)

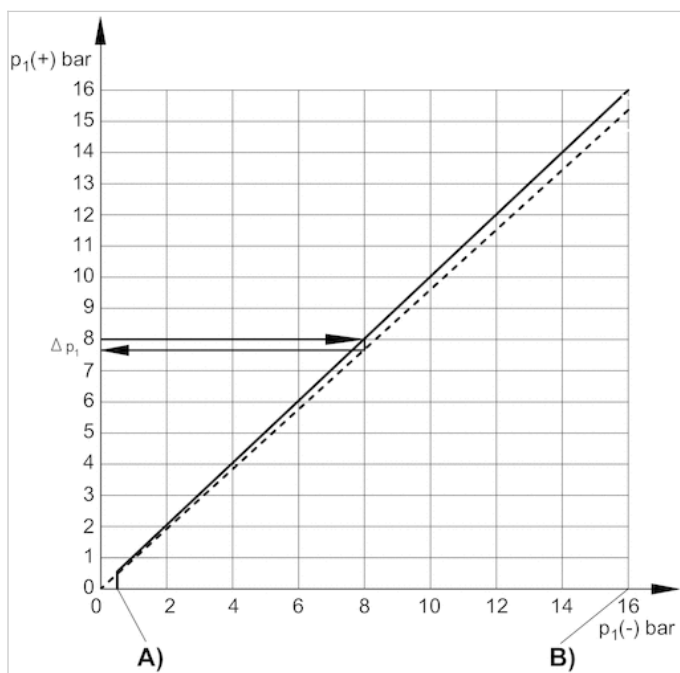
A) $p_1(-)$, min.B) $p_1(-)$, max. $p_1(+)$ = upper switching pressure with increasing pressure $p_1(-)$ = lower switching pressure with decreasing pressure Δp_1 = max. operating pressure difference or hysteresis Example: $p_1(+)$ = 8 bar > $p_1(-)$ = 7.6 bar Δp_1 = 0.4 bar

max. permissible continuous current I max. [A] with ohmic load

U [V]	I [A] 1)	I [A] 2)
30	5	3
48	5	1,2
60	5	0,8
125	5	0,4
250	5	–

reference cycle: 30/min., reference temperature: + 30 °C

1) AC

2) DC

max. permissible continuous current I max. [A] with inductive load

U [V]	I [A] 1) 3)	I [A] 2) 4)
30	3	2
48	3	0.55
60	3	0.4
125	3	0.15
250	3	–

reference cycle: 30/min., reference temperature: + 30 °C

1) AC

2) DC

3) $\cos \approx 0,7^\circ$

4) L/R ≈ 10 ms

Pin assignments

PIN assignment for valve plug connectors

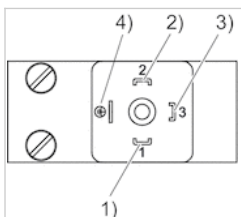

1) +UB

2) electric for 12-24 V DC, break contact

3) NO (make contact)

4) GND