

HD-2-FM Controlair® Valve

Service Information



Figure 1.

DESCRIPTION OF MODELS

The HD-2-FM CONTROLAIR Valve, designed for marine service, is a handle operated pressure control and directional flow control valve. It contains two PILOTAIR® valves, which are arranged to furnish inlet air pressure to two directional control lines and a pressure regulating portion to furnish graduated pressure to a third control line.

The selection between the two directional control lines depends upon handle movement to either side of "Neutral" position. The pressure in the graduated control line is proportional to the position of the handle in either quadrant.

The L-shaped handle, designed so that when two units are mounted side by side they can be operated by one hand, is equipped with an adjustable friction control brake to hold the handle in any selected position in the travel arc.

WARNING: INSTALLATION AND MOUNTING

The user of these devices must conform to all applicable electrical, mechanical, piping and other codes in the installation, operation or repair of these devices.

INSTALLATION! Do not attempt to install, operate or repair these devices without proper training in the technique of working on pneumatic or hydraulic systems and devices, unless under trained supervision.

Compressed air and hydraulic systems contain high levels of stored energy. Do not attempt to connect, disconnect or repair these products when a system is under pressure. Always exhaust or drain the pressure from a system before performing any service work. Failure to do so can result in serious personal injury.

MOUNTING! Devices should be mounted and positioned in such a manner that they cannot be accidentally operated.

INSTALLATION

The HD-2-FM CONTROLAIR is designed for panel mounting. The valve may be installed and removed from the top. Refer to page 2 for panel opening and thickness dimensions. All piping connections are made to a removable pipe bracket. Piping connections need not be broken to remove the valve for service. Loosen bolts 4 to remove the CONTROLAIR Valve.

Two units can be operated simultaneously with one hand if desired. Mount the units side by side with the pipe brackets 180° apart. The L-shaped handles will come close enough together to be manipulated with one hand.

Before installing the CONTROLAIR Valve, all air lines in the system should be blown clean to remove any moisture, dirt, or harmful contamination. Strainers are furnished in all ports to protect the valve from large particles of foreign matter in the line. To further ensure long, trouble-free service, a 10 MICRON or better filter should be installed in the IN port (No. 2 on the pipe bracket) of the HD-2-FM CONTROLAIR Valve.

MAINTENANCE

Maintenance periods should be scheduled in accordance with frequency of use and working environment of the HD-2-FM CONTROLAIR Valve.

One complete CONTROLAIR Valve should be kept for each four valves in service. During the maintenance period, replace the complete valve with the "stand-by" unit. This will reduce production time loss and afford inspection and replacement of worn parts at a more appropriate or opportune time and favorable location.

Notice that the operating portion of a valve can be removed without disturbing the pipe connections. Remove the valve from the pipe bracket by loosening (4) bolts and lift the unit free.

No special tools are required to maintain the CONTROLAIR Valve.

All valves must be visually inspected for wear and given an "in system" operating performance and leakage test at least once a year. If these visual observations indicate valve repair is required, the valve must be removed, repaired and tested.

A major overhaul is recommended at one million cycles. However, where frequency of use is such that it would require more than two years to obtain one million cycles, the valve must be overhauled at the two year period.

When it is determined that the CONTROLAIR Valve requires a major repair as a result of the one million cycles, one year routine inspection, or the two year service period has elapsed, the device must be disassembled, cleaned, inspected, parts replaced as required, rebuilt and tested for leakage, and proper operation prior to installation. Refer to MAJOR REPAIR AND MAINTENANCE INSTRUCTION, page 1, and TEST PROCEDURES, page 2.

MAJOR REPAIR AND MAINTENANCE INSTRUCTION

When it is determined that the CONTROLAIR® Valve requires shop repairs (see page 1 for GENERAL MAINTENANCE AND REPAIR RECOMMENDATIONS), the following general instructions are recommended:

Disassembly, Cleaning and Lubrication

Completely disassemble the CONTROLAIR Valve. Wash all metal parts in a non-flammable solvent. Rinse each part thoroughly and blow dry with a low pressure air jet. Arrange the parts on a clean surface.

Inspect and clear strainers (17). Be sure all body and bracket passages are clear and unrestricted. Be sure sensing port orifice in top of diaphragm chamber is clear.

Examine each part carefully. Replace all rubber parts and all other worn or damaged parts. The use of REPAIR KITS R431006521 [P - 064894-00002] is strongly recommended; see page 2

Reassembly

Valve should be reassembled using new rubber parts and parts indicated by inspection. As reassembly proceeds, lubricate all metal-to-metal wear surfaces with 107 Lubriplate Grease. Lubricate all rubber parts, except diaphragm, with No. 55 Dow Corning Pneumatic Grease. **Do not lubricate diaphragm.** The exhaust valve and seat may have to be slightly polished for minimum leakage. If necessary, use BW valve lapping compound (600+ grit).

The valve is factory set to provide the appropriate graduated pressure and mechanical operation per part number (see IDENTITY SCHEDULE, page 3). However, after the CONTROLAIR Valve has been disassembled, repaired and reassembled, it must be adjusted and tested for proper operation prior to returning to service. It is recommended that the valve should be connected in a test set up as shown in Figure 2.

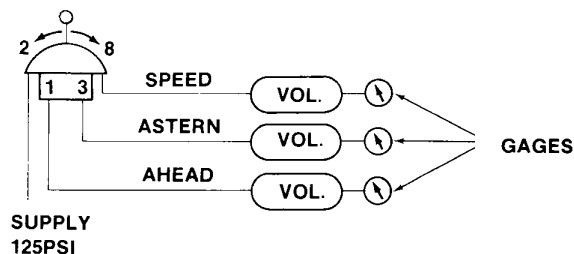

Figure 2.

Use the adjustment set-up illustrated above.

ADJUSTMENTS, TESTING AND TEST SETUP

Four adjustments can be made to the HD-2-FM CONTROLAIR Valve. Adjusting screw (40) changes the maximum and minimum pressure setting, set screw (23) varies the pickup points of valve levers (20) and (22), nut (50) alters the force to move the handle and cam dog pin (19) aligns the cam dog to the cam.

PILOT VALVE LEVER ADJUSTMENT

Remove valve protector (16) and (17). Move the handle (52) back and forth on both sides of the "Neutral" position, observing the action of levers (20) and (22). The corresponding pilot valve should be fully open after the handle moves through the first 15° travel arc. If the pilot valve levers need adjusting, place the handle in a maximum increasing pressure position.

With a 3/32" Allen wrench, turn screw (23) of the activated lever [either (20) or (22)] out, just far enough to crack the exhaust valve.

The gauge (port 1 or port 3) will show a drop in pressure. From this point turn the screw in a full three (3) turns. This will open the inlet valve of the pilot valve to its maximum capacity.

PRESSURE SETTING ADJUSTMENT

Adjusting screw (40) varies the minimum and maximum pressure setting a like amount without changing the range of pressure. Turning the adjusting screw in raises the maximum and minimum pressure (port 8), turning it out decreases the maximum and minimum pressure.

Place the CONTROLAIR Valve handle (52) in the maximum increasing pressure position and turn the adjusting screw (40) in or out until the desired maximum pressure is seen on the air gauge from port 8.

FRICITION BRAKE ADJUSTMENT

The handle force of the HD-2-FM CONTROLAIR Valve can be varied by adjusting the nut (50). This adjustment increases or decreases the manual force required to move or hold the handle in any desired position in the handle quadrant.

CAM DOG ADJUSTMENT

Move device handle to Full Travel in one direction. Observe gauge in port 8 and note the pressure. Place the handle in the opposite position, turn the eccentric cam dog pin (19) to position the cam dog until the pressure is halfway between the pressure from port 8 and the maximum pressure range per valve schedule. Repeat pressure setting adjustment.

OPERATION

Refer to the diagrammatic view (Figure 3). With the handle in "Neutral" position, ports 1 and 3 are open to atmosphere through their respective pilot valves and port 8 is at minimum pressure.

The handle operates a concentric cam. The peripheral surface of the larger section is contoured to provide minute positioning increments to the pressure control portion. The OUT port of the pressure control portion is port 8. The side cam surface moves the right and left pilot levers alternately to operate the on-off pilot valves. The OUT ports for the pilot valves are 1 and 3.

Movement of the handle in the first 15° of the handle quadrant opens the inlet valve of the control portion (with preload setting). Graduated pressure flows out of port 8; the activated pilot valve lever closes the exhaust of the directional pilot valve and opens the inlet valve of one of the pilot valves to pass full supply pressure to port 1 or 3, depending on the quadrant the handle is in. Movement of the handle beyond 15° of the handle quadrant increases the pressure at port 8. As the handle is advance toward the maximum pressure position, the pressure at port 8 increases proportionately and the pressure at port 1 or 3 remains at full supply pressure.

The HD-2-FM CONTROLAIR Valve will automatically compensate for downstream pressure changes at port 8. The air pressure changes can be caused by line leakage, temperature changes, or load thrust. If air pressure at port 8 increases over that called for by handle position, the diaphragm (37) in the control portion will deflect downward moving the exhaust valve seat (42) away from the inlet and exhaust valve unit (34) and vent the excess pressure. If the pressure drops below that called for by handle position, the control spring will force the diaphragm (37) upward.

The exhaust valve seat (42) will move the inlet and exhaust valve unit (34) from its seat, opening the IN port 2 to the OUT port 8 to restore the pressure called for.

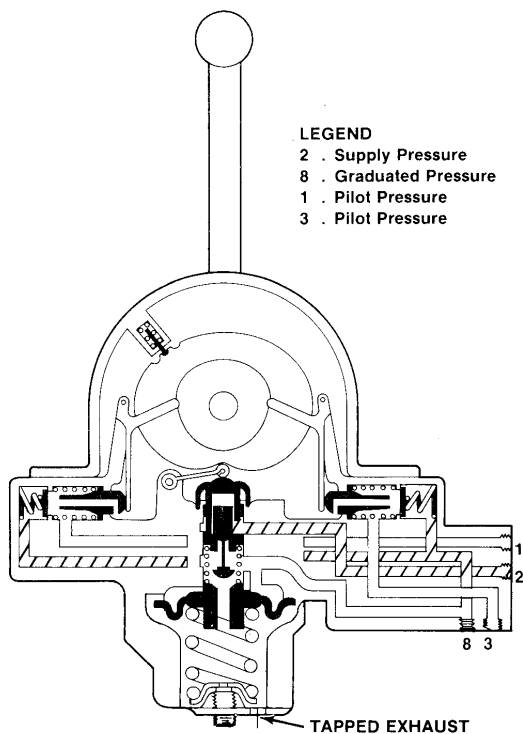
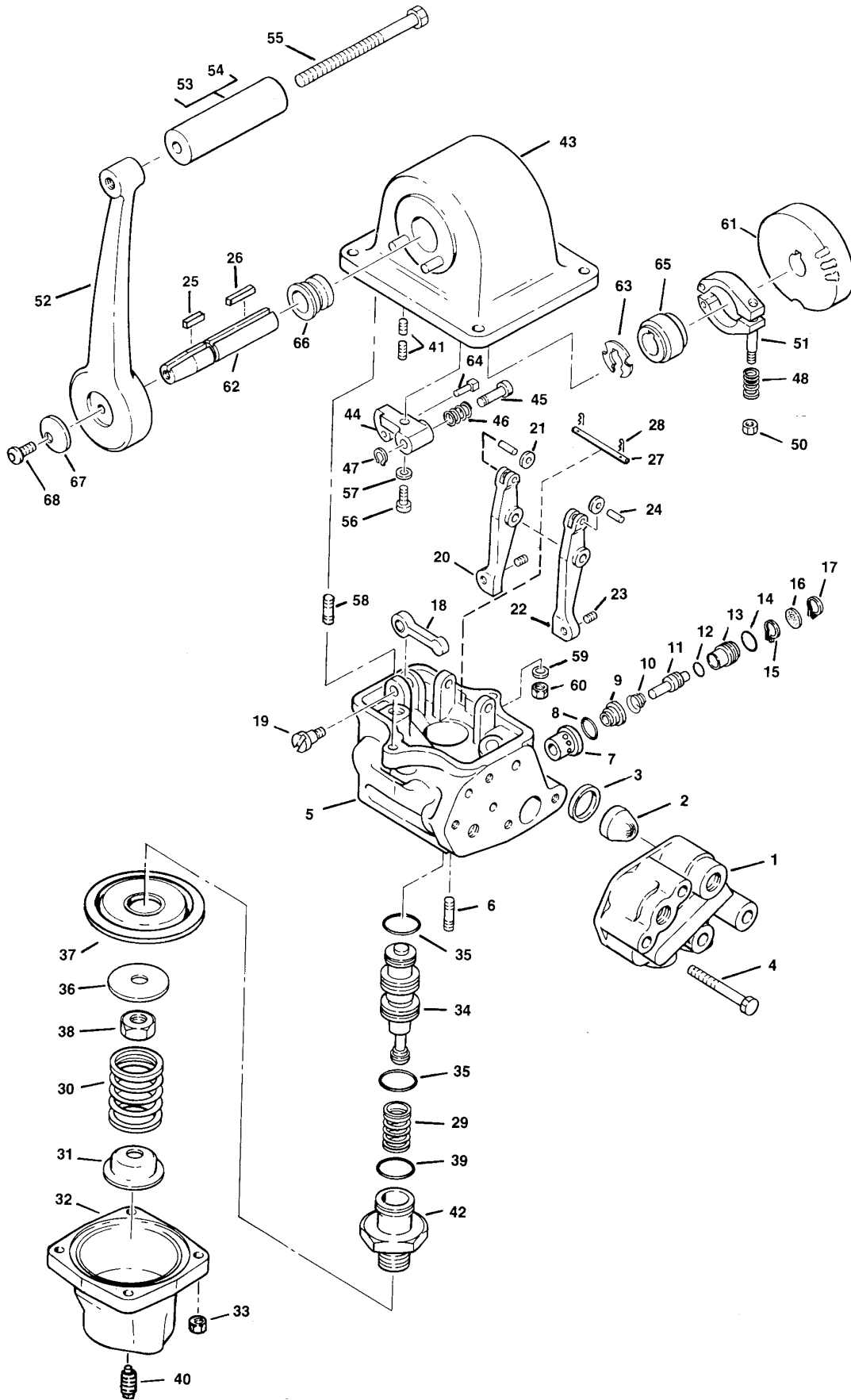

Figure 3. Diagrammatic View

IDENTITY SCHEDULE									
HD-2-FM NEW P/N NEW P/N OLD P/N		DESCRIPTION	DELIVERY PRESSURE RANGE	CONTROL SPRING		CAM HOUSING COMPLETE		VALVE PORTION COMPLETE LESS BRACKET & SCREWS	
NEW P/N	OLD P/N			NEW P/N	OLD P/N	NEW P/N	OLD P/N	NEW P/N	OLD P/N
R431006283	P -063470 - 00111	Wood grip	10-65 psi	R431003732	P -055442- 00000	R431002874	P -051133- 00001	R431003847	P -055586- 00001
R431006281	P -063470- 00101	Chrome grip	10-65 psi	R431003732	P -055442- 00000	R431006286	P -063490- 00002	R431003847	P -055586- 00001
R431006282	P -063470- 00109	Chrome grip	30-70 psi	R431006501	P -064822- 00000	R431006286	P -063490- 00002	R431003851	P -055586- 00016
R431009002	P -028131- 00000	Chrome Center Grip	10-65 psi	R431003732	P -055442- 00000	R431006291	P -063490- 00009	R431003847	P -055586- 00001

Maximum operating pressure	200 psi (13.8 bar)
Admissible Medium	Air, clean and dry
Operating Temperature	-40°F to +160°F (-40°C to +71°C)
Hysteresis	1 ½ psi (0.10 bar)
Control Pressure Range	See Identity Schedule
Pressure Change	½ psi (0.03 bar) increment
Mounting	Flange plate
Port size	½" - 18 NPTF
Materials	
Controlair Valve Housing and Body	Die cast aluminum
Internal Parts	Brass, rubber (Buna-N), aluminum, steel
Weight	Approx. 4.5 lbs. (2.0 kg)

EXPLODED VIEW



PARTS LIST

REF.	QTY	DESCRIPTION	NEW P/N	OLD P/N	REF.	QTY	DESCRIPTION	NEW P/N	OLD P/N
1	1	Pipe bracket	See Kit	See Kit	40	1	Screw, Spline Hex Adj.	R431006770	P -066209-00000
2	5	Strainer, port	See Kit	See Kit	41	2	Screw, 10-24 x .38	R431002492	P -049905-00041
3	5	Gaskets	See Kit	See Kit	42*	1	Seat, Exhaust valve	See Kit	See Kit
4	4	Screw, 5/16"x 2-1/4	See Kit	See Kit	43	1	Housing, Cam Complete	R431002657	P -050506-00030
5	1	Body, Complete (Includes item #6)	R431002869	P -051112-00002	44	1	Latch, Body	R431002659	P -050509-00000
6	4	Stud, 5/16-18 x 1-3/8	R431002504	P -049906-00000	45	1	Latch, Cam	R431002660	P -050520-00000
7*	1	Valve, Inlet supply	See Kit	See Kit	46	1	Spring, Latch	R431000020	-521116-00000
8*	2	Ring, 7/8 OD	See Kit	See Kit	47	1	Ring, Retainer	R431002337	P -049857-00019
9*	2	Seat, Supply valve	See Kit	See Kit	48	1	Spring	R431000158	-850537-00000
10*	2	Spring, Exhaust valve	See Kit	See Kit	50	1	Nut, 10-32	R431002556	P -049923-00008
11*	2	Plunger	See Kit	See Kit	51	1	Shoe and Holder Assy	R431002705	P -050654-00000
12*	2	Ring, 7/16 OD	See Kit	See Kit			Handle Assy Cp		
13*	2	Plunger, Guide	See Kit	See Kit	1		[for P -063470-00001, incl ref. 52, 54, 55]	—	P -063462-00000
14*	2	Ring, 15/16 OD	See Kit	See Kit			Handle Assy Cp		
15*	2	Ring, Retainer	See Kit	See Kit	1		[for P -063470-00101 & P -063470-00109, incl ref. 52, 53, 55]	R431006272	P -063462-00001
16*	2	Washer	See Kit	See Kit	52	1	Handle	R431006278	P -063466-00000
17*	2	Ring, Snap	See Kit	See Kit			Grip, Handle		
18*	1	Dog, Cam	See Kit	See Kit	53	1	[for P -063470-00101 & P -063470-00109]	R431006490	P -064743-00000
19	1	Pin, Dog	R431002950	P -051856-00000	54	1	Wood Grip, Handle [for P -063470-00001]	R431006280	P -063467-00000
20	1	Lever, RT	R431004872	P -058979-00002	55	1	Screw, 3/8-16 x 2-1/2	R431002316	P -049856-00129
21	2	Roller	R431002911	P -051530-00000	56	1	Screw, 1/4-20	R431002512	P -049908-00009
22	1	Lever, LT	R431004869	P -058978-00002	57	1	Washer, 1/4	R431002377	P -049880-00001
23	2	Screw, 1/4-28 x 1/2 - Lever	R431001872	P -049590-00000	58	2	Stud, 5/16-18	R431002504	P -049906-00000
24	2	Pin, 3/16 Lever - RT, LT	R431002774	P -050856-00000	59	2	Washer, 5/16	R431002540	P -049911-00002
25	1	Key	R431002378	P -049881-00006	60	2	Nut, 5/16-18	R431002416	P -049901-00001
26	1	Key	R431002381	P -049881-00013	61	1	Cam	R431006252	P -063422-00001
27	1	Pin, Lever	R431002722	P -050686-00007	62	1	Shaft, Cam	R431006275	P -063463-00000
28	2	Pin, 1/16 x 1/2	R431002541	P -049913-00001	63	1	Ring, Retainer	R431001724	P -049208-00000
29*	1	Spring, Exhaust valve	See Kit	See Kit	64	1	Pin, Brake	R431002661	P -050524-00000
30	1	Spring, Diaphragm	See Page 3	See Page 3	65	1	Drum, Brake	R431006276	P -063464-00000
31	1	Seat, Spring	R431000036	-526347-00000	66	1	Bushing, Cam Shaft	R431002662	P -050525-00002
32	1	Housing, Spring Complete	R431006822	P -066488-00002	67	1	Washer	R431006277	P -063465-00000
33	4	Nut, 5/16-18	R431002416	P -049901-00001	68	1	Screw, 1/4-20	R431001896	P -049609-00014
34*	1	Valve, Inlet & Exhaust [Incl. #35]	See Kit	See Kit					
35*	2	Ring, 3/4 OD	See Kit	See Kit					
36*	1	Follower, Diaphragm	See Kit	See Kit					
37*	1	Diaphragm	See Kit	See Kit					
38*	1	Nut, 9/16-18	See Kit	See Kit					
39*	1	O-Ring, 11/16	See Kit	See Kit					

* REPAIR KIT, Major Complete (1) R431006521 - (P -064894-00002)

REPAIR KIT LIST FOR VALVE PORTION	
PART NO.	DESCRIPTION
R431003892 (P -055687-00000)	For All Models: Kit, graduating valve (except H-3-G and H-4-G models) (lapped set of inlet and exhaust valve unit, exhaust valve seat, diaphragm, and O-rings)
R431004886 (P -059028-00000)	Kit, major, valve portion (R431003892 kit, gaskets and strainers, exhaust valve spring, dirt protector, O-rings, cam dog)
R431003743 (P -055474-K0002)	For HD-2 Models: Kit, minor, side valve (Inlet valve assembly and seals)
R431003985 (P -057094-00001)	Kit, major, side valve (R431003743 kit, plunger, guide and snap rings)
R431004005 (P -057136-00000)	Kit, major, graduating valve (R431003892 kit gaskets and strainers, exhaust valve spring, O-rings, cam dog)
R431006521 (P -064894-00002)	Kit, major, valve portion, HC-2 and HD-2 models (R431004005 kit and (2) R431003985 kits)

These kits contain some common parts to renew the valve portions only. For severely worn or damaged valve portions, select additional parts from appropriate service bulletins. All kits contain a small tube of recommended lubricant.

OUTLINE DIMENSIONS

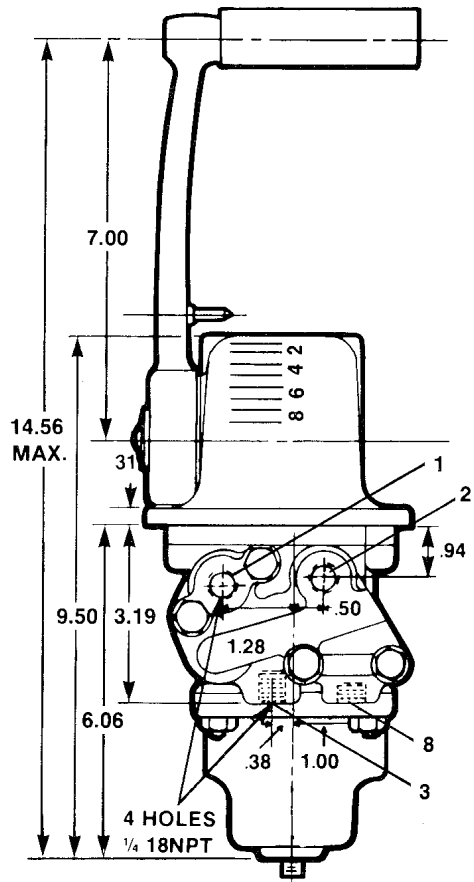
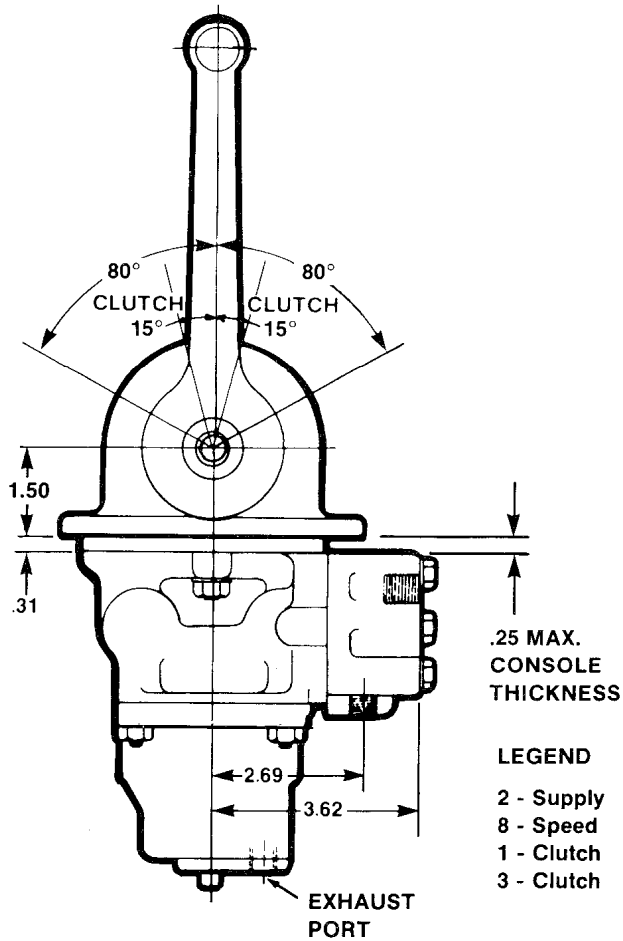
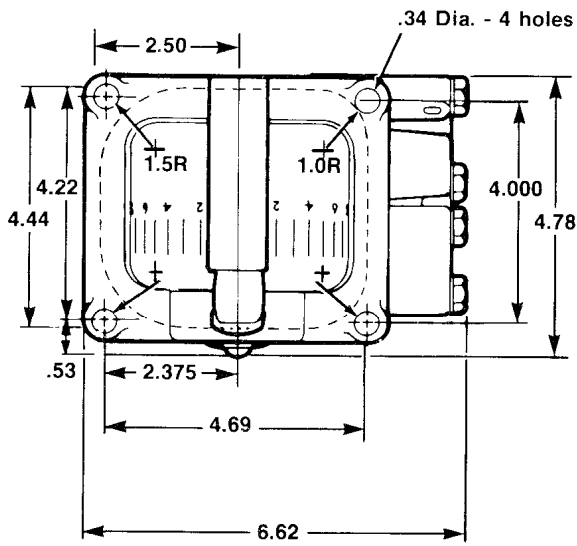

Figure 5.

NOTICE TO PRODUCT USERS

1. WARNING: FLUID MEDIA

Bosch Rexroth pneumatic devices are designed and tested for use with filtered, clean, dry, chemical free air at pressures and temperatures within the specified limits of the device. For use with media other than air or for human life support systems, Bosch Rexroth must be consulted. Hydraulic cylinders are designed for operation with filtered, clean, petroleum based hydraulic fluid; operation using fire-resistant or other special types of fluids may require special packing and seals. Consult the factory.

2. WARNING: MATERIAL COMPATIBILITY

Damage to product seals or other parts caused by the use of noncompatible lubricants, oil additives or synthetic lubricants in the air system compressor or line lubrication devices voids Bosch Rexroth's warranty and can result in product failure or other malfunction. See lubrication recommendations below.

AIR LINE LUBRICANTS! In service higher than 18 cycles per minute or with continuous flow of air through the device, an air line lubricator is recommended.* (Do not use line lubrication with vacuum products.) However, the lubricator must be maintained since the oil will wash out the grease, and lack of lubrication will greatly shorten the life expectancy. The oils used in the lubricator must be compatible with the elastomers in the device. The elastomers are normally BUNA-N, NEOPRENE, VITON, SILICONE and HYTREL. Bosch Rexroth recommends the use of only petroleum based oils without synthetic additives, and with an aniline point between 180° F and 210° F.

COMPRESSOR LUBRICANTS! All compressors (with the exception of special "oil free" units) pass oil mist or vapor from the internal crankcase lubricating system through to the compressed air. Since even small amounts of non-compatible lubricants can cause severe seal deterioration (which could result in component and system failure) special care should be taken in selecting compatible compressor lubricants. It is recommended that users review the National Fluid Power Association "Recommended Guide Lines For Use Of Synthetic Lubricants In Pneumatic Fluid Power Systems" (NFPA T1.9.2-1978).

3. WARNING: INSTALLATION AND MOUNTING

The user of these devices must conform to all applicable electrical, mechanical, piping and other codes in the installation, operation or repair of these devices.

INSTALLATION ! Do not attempt to install, operate or repair these devices without proper training in the technique of working on pneumatic or hydraulic systems and devices, unless under trained supervision. Compressed air and hydraulic systems contain high levels of stored energy. Do not attempt to connect, disconnect or repair these products when a system is under pressure. Always exhaust or drain the pressure from a system before performing any service work. Failure to do so can result in serious personal injury.

MOUNTING! Devices should be mounted and positioned in such a manner that they cannot be accidentally operated.

4. WARNING: APPLICATION AND USE OF PRODUCTS

The possibility does exist for any device or accessory to fail to operate properly through misuse, wear or malfunction. The user must consider these possibilities and should provide appropriate safe guards in the application or system design to prevent personal injury or property damage in the event of a malfunction.

5. WARNING: CONVERSION, MAINTENANCE AND REPAIR

When a device is disassembled for conversion to a different configuration, maintenance or repair, the device must be tested for leakage and proper operation after being reassembled and prior to installation.

MAINTENANCE AND REPAIR! Maintenance periods should be scheduled in accordance with frequency of use and working conditions. All Bosch Rexroth products should provide a minimum of 1,000,000 cycles of maintenance free service when used and lubricated as recommended. However, these products should be visually inspected for defects and given an "in system" operating performance and leakage test once a year. Where devices require a major repair as a result of the one million cycles, one year, or routine inspection, the device must be disassembled, cleaned, inspected, parts replaced as required, rebuilt and tested for leakage and proper operation prior to installation. See individual catalogs for specific cycle life estimates.

6. PRODUCT CHANGES

Product changes including specifications, features, designs and availability are subject to change at any time without notice. For critical dimensions or specifications, contact factory.

*Many Bosch Rexroth pneumatic valves and cylinders can operate with or without air line lubrication; see individual sales catalogs for details.

LIMITATIONS OF WARRANTIES & REMEDIES

Bosch Rexroth warrants its products sold by it to be free from defects in material and workmanship to the following:

For twelve months after shipment Bosch Rexroth will repair or replace (F.O.B. our works), at its option, any equipment which under normal conditions of use and service proves to be defective in material or workmanship at no charge to the purchaser. No charge will be made for labor with respect to defects covered by this Warranty, provided that the work is done by Bosch Rexroth or any of its authorized service facilities. However, this Warranty does not cover expenses incurred in the removal and reinstallation of any product, nor any downtime incurred, whether or not proved defective.

All repairs and replacement parts provided under this Warranty policy will assume the identity, for warranty purposes, of the part replaced, and the warranty on such replacement parts will expire when the warranty on the original part would have expired. Claims must be submitted within thirty days of the failure or be subject to rejection.

This Warranty is not transferable beyond the first using purchaser. Specifically, excluded from this Warranty are failures caused by misuse, neglect, abuse, improper operation or filtration, extreme temperatures, or unauthorized service or parts. This Warranty also excludes the use of lubricants, fluids or air line additives that are not compatible with seals or diaphragms used in the products. This Warranty sets out the purchaser's exclusive remedies with respect to products covered by it, whether for negligence or otherwise. Neither, Bosch Rexroth nor any of its affiliates will be liable for consequential or incidental damages or other losses or expenses incurred by reason of the use or sale of such products. Our liability (except as to title) arising out of the sale, use or operation of any product or parts, whether on warranty, contract or negligence (including claims for consequential or incidental damage) shall not in any event exceed the cost of replacing the defective products and, upon expiration of the warranted period as herein provided, all such liability is terminated. THIS WARRANTY IS IN LIEU OF ALL OTHER WARRANTIES, EXPRESS OR IMPLIED, WHETHER FOR MERCHANTABILITY OR FITNESS FOR A PARTICULAR PURPOSE OR OTHERWISE. No attempt to alter, amend or extend this Warranty shall be effective unless authorized in writing by an officer of Bosch Rexroth Corporation.

Bosch Rexroth reserves the right to discontinue manufacture of any product, or change product materials, design or specifications without notice.

Bosch Rexroth Corporation
Pneumatics
1953 Mercer Road
Lexington, KY 40511-1021
Telephone (859) 254-8031
Facsimile (859) 254-4188
pneumatics@boschrexroth-us.com
www.boschrexroth-us.com/brp

International offices:

Asia:

China	Russia
India	Singapore
Japan	South Korea
Malaysia	

Australia

Europe:

Austria	Netherlands
Belgium	Norway
Bulgaria	Poland
Czech Republic	Portugal
Denmark	Romania
Finland	Slovakia
France	Spain
Germany	Sweden
Greece	Switzerland
Hungary	Turkey
Italy	Ukraine
United Kingdom	

North America:

Canada	United States
Mexico	

South America:

Argentina	Venezuela
Brazil	

**Factory Automation
Regional sales offices:**

Central

Bosch Rexroth Corporation
5150 Prairie Stone Parkway
Hoffman Estates, IL 60192-3707
Telephone (847) 645-3600
Facsimile (847) 645-0804

Great Lakes

Bosch Rexroth Corporation
2730 Research Drive
Rochester Hills, MI 48309
Telephone (248) 393-3330
Facsimile (248) 393-2893

Northeast

Bosch Rexroth Corporation
99 Rainbow Road
East Granby, CT 06026-0000
Telephone (860) 844-8377
Facsimile (860) 844-8595

Bosch Rexroth Corporation
2315 City Line Road
Bethlehem, PA 18017-2131
Telephone (610) 694-8300
Facsimile (610) 694-8467

Southeast

Bosch Rexroth Corporation
14001 South Lake Drive
Charlotte, NC 28273-5544
Telephone (704) 583-4338
Facsimile (704) 583-0523

West

Bosch Rexroth Corporation
11 Goddard
Irvine, CA 92618-4600
Telephone (949) 450-2777
Facsimile (949) 450-2790

North American offices:

Bosch Rexroth Corporation
Corporate Headquarters
5150 Prairie Stone Parkway
Hoffman Estates, IL 60192-3707
Telephone (847) 645-3600
Facsimile (847) 645-0804

Bosch Rexroth Corporation
Industrial Hydraulics
2315 City Line Road
Bethlehem, PA 18017-2131
Telephone (610) 694-8300
Facsimile (610) 694-8467

Bosch Rexroth Corporation
Electric Drives and Controls
5150 Prairie Stone Parkway
Hoffman Estates, IL 60192-3707
Telephone (847) 645-3600
Facsimile (847) 645-6201

Bosch Rexroth Corporation
Linear Motion and Assembly
Technologies
816 E. Third Street
Buchanan, MI 49107
Telephone (269) 695-0151
Facsimile (269) 695-5363

14001 South Lakes Drive
Charlotte, NC 28273
Telephone (800) 438-5983
Facsimile (704) 583-0523

Bosch Rexroth Corporation
Mobile Hydraulics
145 Southchase Boulevard
Fountain Inn, SC 29644-9018
Telephone (864)967-2777
Facsimile (864)962-5338

Bosch Rexroth Canada
3426 Mainway Drive
Burlington, Ontario L7M 1A8 Telephone
(905) 335-5511 Facsimile (905) 335-4184
www.boschrexroth.ca

Bosch Rexroth, S.A. de C.V.
Calle Neptuno # 72
Unidad Industrial Vallejo
CP 07700 Mexico, D.F.
Telephone (555) 754-1711
Facsimile (555) 752-5943

Further contacts:
www.boschrexroth.com/addresses

The data specified herein only serves to describe the product. No statements concerning a certain condition or suitability for a certain application can be derived from our information. The given information does not release the user from obligation of own judgment and verification. It must be remembered that our products are subject to a natural process of wear and aging. ©This document, as well as the data, specifications and other information set forth in it, are the exclusive property of Bosch Rexroth Corp. Without their consent it may not be reproduced or given to third parties.