

Taskmaster® Pneumatic Cylinder

MS2 Mounting Kits - 1.5" thru 4" bore

Rexroth
Bosch Group

MS2 Mounting Kit (Steel) 1 1/2" - 2 1/2" Bore

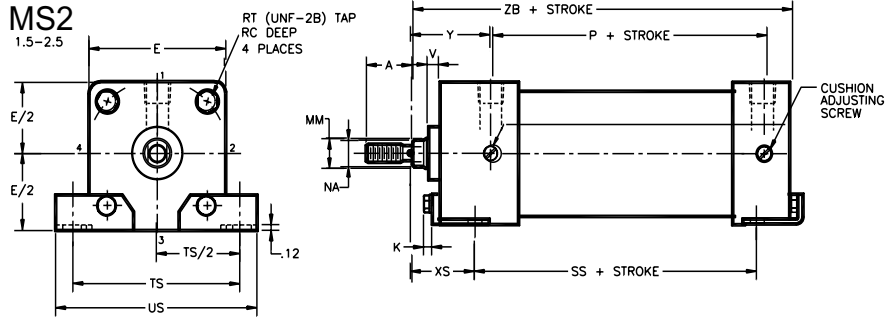

Model	MS2																	
KIT PART NUMBER	WEIGHT	BORE SIZE	MM ROD	C	F	K	W*	SB	SS	ST	SU	SW	SY	SZ	TS	US	XS*	ZB*
R432013616	0 lb. 6 oz.	1.500	0.625	0.75	2.00	0.23	0.59	0.44	2.88	0.12	0.48	0.88	0.90	0.50	2.75	3.43	1.38	4.62
R432013641	0 lb. 6 oz.	2.000	0.625	0.75	2.50	0.28	0.59	0.44	2.88	0.12	0.48	0.88	0.90	0.50	3.32	4.08	1.38	4.62
R432013641	0 lb. 6 oz.	2.500	0.625	0.75	3.00	0.28	0.59	0.44	3.00	0.12	0.48	0.88	0.90	0.50	3.67	4.43	1.38	4.75

Mounting kit only, order cylinder separately. These kits fit first and second rod sizes. Dimensions in inches, for those not shown see MS4 basic cylinder drawing.

*Dimensions are for TM-8 series, for TM-1 series see MS4 basic cylinder drawing.

MS2 Mounting Kit (Steel) 3 1/4" - 4" Bore

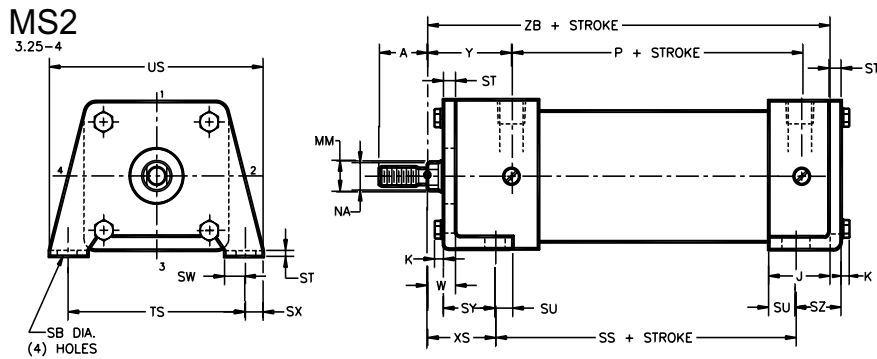

Model	MS2																	
KIT PART NUMBER	WEIGHT	BORE SIZE	MM ROD	E	K	W*	SB	SS	ST	SU	SW	SX	SY	SZ	TS	US	XS*	ZB*
R432013648	2 lb. 12 oz.	3.250	1.000	3.75	0.34	0.75	0.56	3.25	0.25	0.62	0.50	0.50	1.38	0.75	4.75	5.75	1.88	5.62
R432013651	4 lb. 4 oz.	4.000	1.000	4.50	0.34	0.75	0.56	3.25	0.31	0.62	0.50	0.50	1.44	0.81	5.50	6.50	1.88	5.62

Mounting kit only, order cylinder separately. These kits fit first and second rod sizes. Dimensions in inches, for those not shown see MS4 basic cylinder drawing.

*Dimensions are for TM-8 series, for TM-1 series see MS4 basic cylinder drawing.