



NV/NVL FULL SIZE NEEDLE VALVE

Strong and Durable, Full Size Needle Valve
Pressures up to 6,000 psi soft seat, 10,000 psi hard seat

SPECIFICATIONS

Series Number	“NV” or “NVL” (1/4”)
Material	Carbon steel or 316 stainless steel See chart below for component materials
Pressure Rating	Soft seat - 6000 psi at 200° F Hard seat - 10,000 psi at 200° F
Connection Size	NV - 1/2” NPT, 3/8” NPT (316 SS only) NVL - 1/4” NPT For 3/4” or 1” sizes, see HV series page 128-129 male x female, female x female
Handle	Tee
Seat Material	Soft Seat - POM
Box Quantity	15 pieces
Est. Unit Weight	1.20 lb/0.54 kg

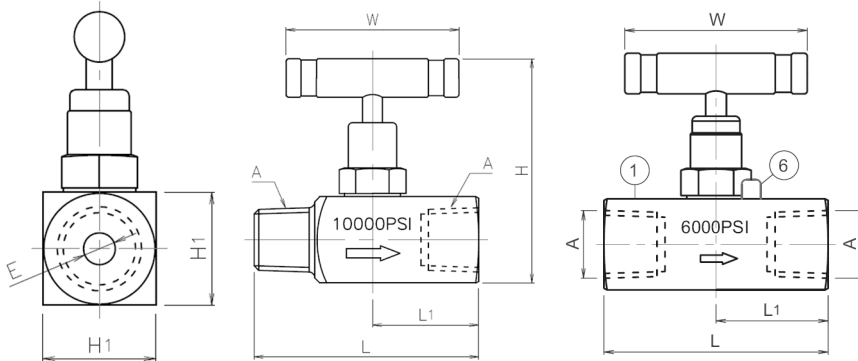
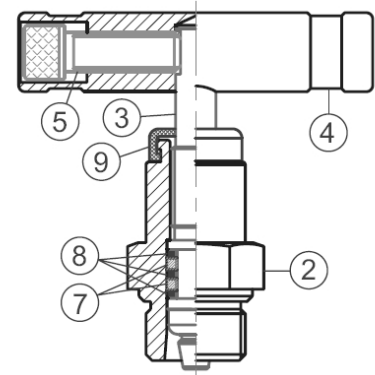
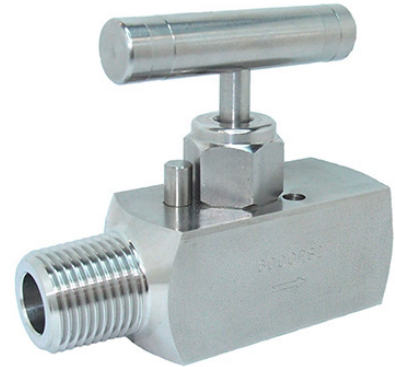

Number	Description	316 Valve	Carbon Steel Valve
1	Body	316 SS	C.S.
2	Bonnet	316 SS	C.S.
3	Stem	316 SS	304 SS
4	Handle	303 SS	C.S.
5	Fixing Screw	302 SS	C.S.
6	Lock Pin	303 SS	C.S.
7	O-Ring	Viton®	Viton®
8	Back-up Ring	PTFE	PTFE
9	Dust Cap	NBR	NBR

Soft Seat Part Number	Unit	A	L	L1	H	H1	E	W
NVL-SS-1/4-GS-180-MXF	In.	1/4",	3.23"	1.38"	3.03"	1.14"	0.18"	2.24"
NVL-CS-1/4-GS-180-MXF		3/8", 1/2"						
NV-SS-3/8-GS-180-MXF	mm	NPT	82	35	77	29	4.5	57
NV-SS-1/2-GS-180-MXF								
NV-CS-1/2-GS-180-MXF								
NVL-CS-1/4-GS-180-FXF	In.	1/4",	2.95"	1.38"	3.03"	1.14"	0.18"	2.24"
NV-SS-3/8-GS-180-FXF		3/8", 1/2"						
NV-SS-1/2-GS-180-FXF	mm	NPT	75	35	77	29	4.5	57
NV-CS-1/2-GS-180-FXF								
NV-CS-1/2-GS-180-FXF								
Hard Seat Part Number	Unit	A	L	L1	H	H1	E	W
NVL-SS-1/4-HS-180-MXF	In.	1/4",	3.23"	1.38"	3.03"	1.14"	0.24"	2.24"
NVL-CS-1/4-HS-180-MXF		3/8", 1/2"						
NV-SS-3/8-HS-180-MXF	mm	NPT	82	35	77	29	6	57
NV-SS-1/2-HS-180-MXF								
NV-CS-1/2-HS-180-MXF								
NV-SS-3/8-HS-180-FXF	In.	3/8", 1/2"	2.95"	1.48"	3.03"	1.14"	0.24"	2.24"
NV-CS-1/2-HS-180-FXF		NPT						
NV-SS-1/2-HS-180-FXF	mm		75	37.5	77	29	6	57
NV-SS-1/2-HS-180-FXF								

AVAILABLE OPTIONS*

- High Temperature
- Panel Mount
- Bleed Screw
- Tube End Connection
- Alternate Connection Sizes
- See HV for Additional Configurations, p. 124-125

All dimensions shown in the catalog are approximate and subject to change.

*Lead times/minimums may apply

A Division of Engineered Specialty Products, Inc.