

Instructions - Parts list



Air Regulator, Filter, and 55 Gallon Suction Kit

308426D

EN

For use in applications using windshield washer solvent. For professional use only.

Model No. 237160, Series A

100 psi (0.7 MPa, 7 bar) Maximum Working Pressure







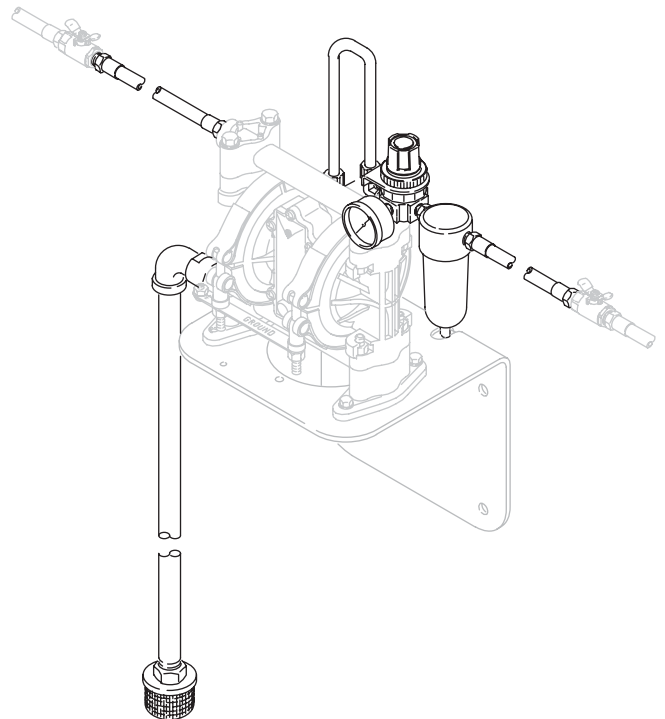

Important Safety Instructions

Read all warnings and instructions in this manual. Save these instructions.



Warnings

The following warnings are for the setup, use, grounding, maintenance, and repair of this equipment. The exclamation point symbol alerts you to a general warning and the hazard symbols refer to procedure-specific risks. When these symbols appear in the body of this manual or on warning labels, refer back to these Warnings. Product-specific hazard symbols and warnings not covered in this section may appear throughout the body of this manual where applicable.

 <h2 style="margin: 0;">WARNING</h2>	
 	<p>EQUIPMENT MISUSE HAZARD</p> <p>Misuse can cause death or serious injury.</p> <ul style="list-style-type: none"> • Do not operate the unit when fatigued or under the influence of drugs or alcohol. • Do not exceed the maximum working pressure or temperature rating of the lowest rated system component. See Technical Data in all equipment manuals. • Use fluids and solvents that are compatible with equipment wetted parts. See Technical Data in all equipment manuals. Read fluid and solvent manufacturer's warnings. For complete information about your material, request MSDS from distributor or retailer. • Do not leave the work area while equipment is energized or under pressure. • Turn off all equipment and follow the Pressure Relief Procedure when equipment is not in use. • Check equipment daily. Repair or replace worn or damaged parts immediately with genuine manufacturer's replacement parts only. • Do not alter or modify equipment. Alterations or modifications may void agency approvals and create safety hazards. • Make sure all equipment is rated and approved for the environment in which you are using it. • Use equipment only for its intended purpose. Call your distributor for information. • Route hoses and cables away from traffic areas, sharp edges, moving parts, and hot surfaces. • Do not kink or over bend hoses or use hoses to pull equipment. • Keep children and animals away from work area. • Comply with all applicable safety regulations.
  	<p>SKIN INJECTION HAZARD</p> <p>High-pressure fluid from dispensing device, hose leaks, or ruptured components will pierce skin. This may look like just a cut, but it is a serious injury that can result in amputation. Get immediate surgical treatment.</p> <ul style="list-style-type: none"> • Do not point dispensing device at anyone or at any part of the body. • Do not put your hand over the fluid outlet. • Do not stop or deflect leaks with your hand, body, glove, or rag. • Follow the Pressure Relief Procedure when you stop dispensing and before cleaning, checking, or servicing equipment. • Tighten all fluid connections before operating the equipment. • Check hoses and couplings daily. Replace worn or damaged parts immediately.

Installation

1. Remove both screws (A) from the top of the pump. Secure the mounting bracket (13) of the regulator assembly (B) to the pump. (FIG. 1)

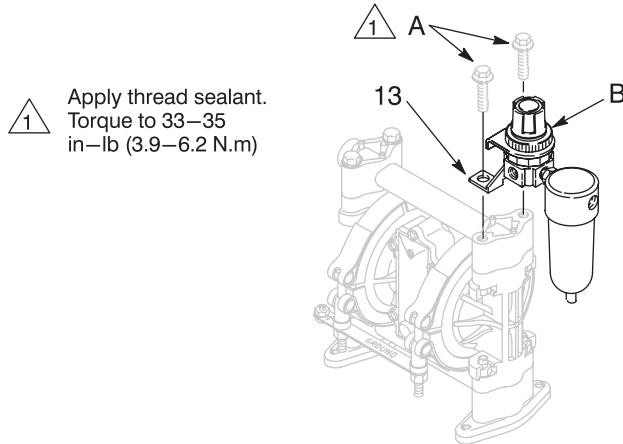

FIG. 1

2. Screw the loose air line fitting (9a) into the pump's air inlet. Rotate the fitting so the tube end faces up. Push each end of the tube (12) into one of the air line fittings. Tighten the nut on the fitting to secure the tube. (FIG. 2)

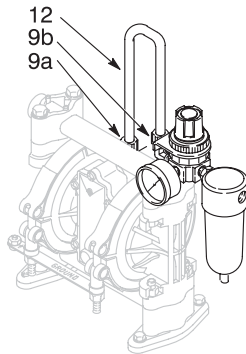

FIG. 2

3. Mount the pump as desired, but be sure the suction hose kit (14) can reach the bottom of the supply container. A wall bracket (F) is shown in FIG. 3.
4. Screw the adapter (10) into the pump inlet. Apply thread sealant to the male threads of the elbow (1). Screw the elbow into the adapter. Screw the suction hose kit (14) into the elbow (1). (FIG. 3)
5. Connect a fluid hose (8) and a fluid shutoff valve (D) at the outlet of the pump. (FIG. 3)

6. Connect an air hose (4) and a bleed-type air shutoff valve (E) at the inlet of the air filter (5). (FIG. 3)

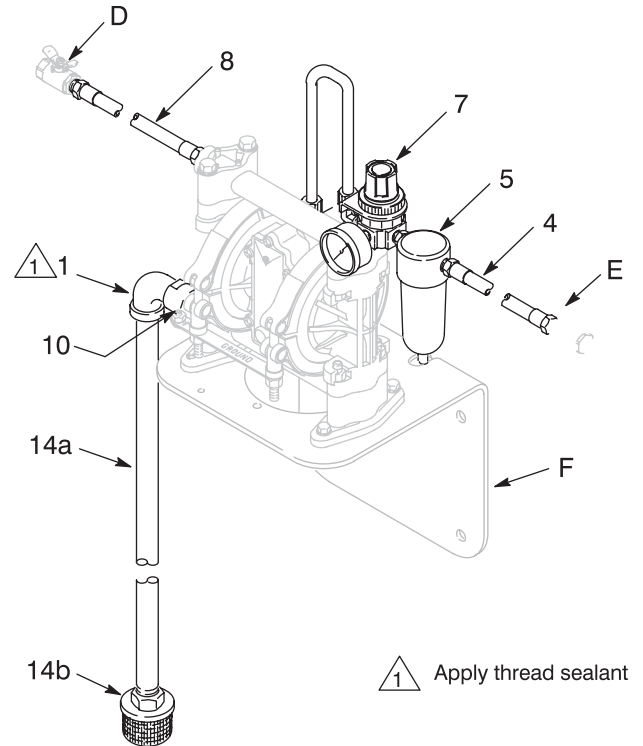

FIG. 3

Operation

Pressure Relief Procedure



Follow the Pressure Relief Procedure whenever you see this symbol.



This equipment stays pressurized until pressure is manually relieved. To help prevent serious injury from pressurized fluid, such as skin injection, splashing fluid and moving parts, follow the Pressure Relief Procedure when you stop spraying and before cleaning, checking, or servicing the equipment.

1. Close the bleed-type air valve (E). (FIG. 3)
2. Close the air regulator (7). (FIG. 3)
3. Trigger or open the dispensing gun to relieve fluid pressure.

Operation Procedure

1. Place the suction tube in the windshield washer fluid.
2. Close the fluid shutoff valve (D).
3. Turn on the air to the pump. Slowly open the air regulator until the pump is running smoothly.
4. When the pump stalls, open the fluid shutoff valve (D).
5. For additional operation information, pump maintenance, trouble shooting and repair, refer to the pump instruction manual 307194.

Parts

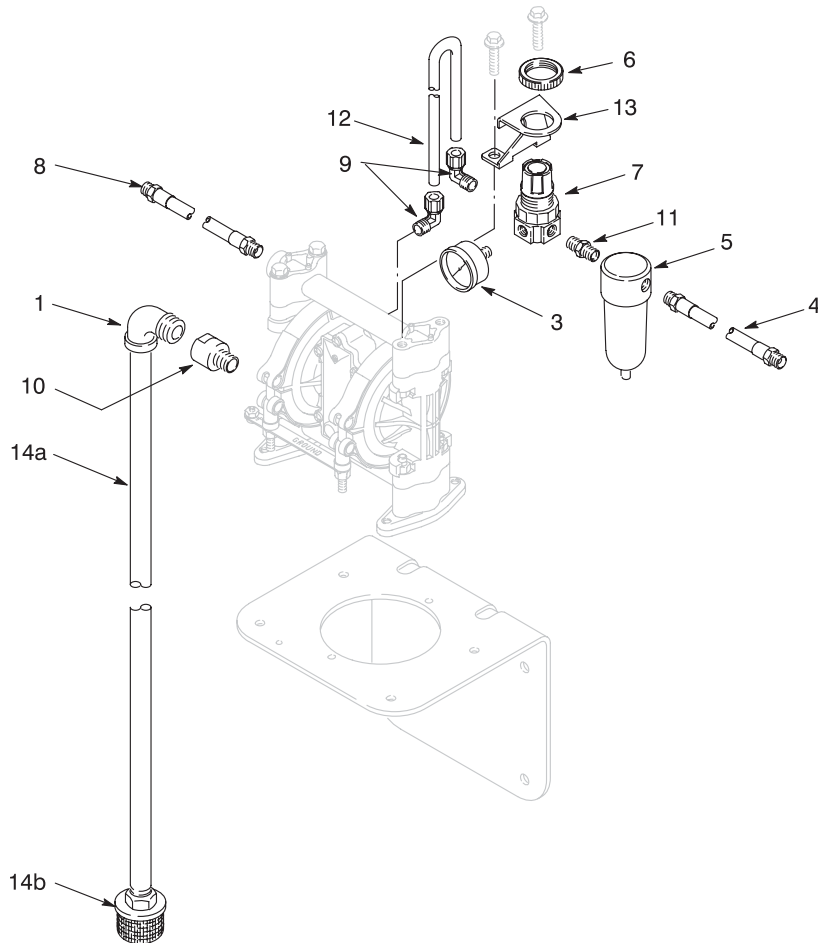

Part No./Description

Ref.	Part	Description	Qty.	Ref.	Part	Description	Qty.
1	100611	ELBOW, 1/2-14 npt(m) x 3/4-14 npt(f)	1	11	156971	NIPPLE, 1/4-18 npt	1
3	108190	AIR GAUGE, 0-100 psi (0-0.7 MPa, 0-7 bar) range	1	12	187479	TUBE, 3/8 inch ID, 15 inch (381 mm) long	1
4	109125	AIR HOSE, 6 ft (1.83 m)	1	13	190125	MOUNTING BRACKET	1
5	110146	AIR FILTER, 1 oz bowl, 1/4 npt(f) inlet and outlet	1	14	223888	SUCTION HOSE KIT, includes items 14a and 14b	1
6	110209	REGULATOR NUT	1	14a	110904	SUCTION HOSE, 6 ft (1.83 m) long, PVC, coupled	1
7	110318	AIR REGULATOR, 1/4 npt	1	14b	218798	STRAINER, 16 mesh, 304 stainless steel	1
8	220596	FLUID HOSE, 4 ft (1.23 m) long, nitrile, coupled, 3/8-18 npt x 1/2-14 npt(mbe)	1				
9	111511	AIR LINE FITTING, 1/4-18 npt(m) x 3/8 inch OD tube	2				
10	156022	ADAPTER, 3/8-18 npt(m) x 1/2-14 npt(f)	1				

Graco Standard Warranty

Graco warrants all equipment referenced in this document which is manufactured by Graco and bearing its name to be free from defects in material and workmanship on the date of sale to the original purchaser for use. With the exception of any special, extended, or limited warranty published by Graco, Graco will, for a period of twelve months from the date of sale, repair or replace any part of the equipment determined by Graco to be defective. This warranty applies only when the equipment is installed, operated and maintained in accordance with Graco's written recommendations.

This warranty does not cover, and Graco shall not be liable for general wear and tear, or any malfunction, damage or wear caused by faulty installation, misapplication, abrasion, corrosion, inadequate or improper maintenance, negligence, accident, tampering, or substitution of non-Graco component parts. Nor shall Graco be liable for malfunction, damage or wear caused by the incompatibility of Graco equipment with structures, accessories, equipment or materials not supplied by Graco, or the improper design, manufacture, installation, operation or maintenance of structures, accessories, equipment or materials not supplied by Graco.

This warranty is conditioned upon the prepaid return of the equipment claimed to be defective to an authorized Graco distributor for verification of the claimed defect. If the claimed defect is verified, Graco will repair or replace free of charge any defective parts. The equipment will be returned to the original purchaser transportation prepaid. If inspection of the equipment does not disclose any defect in material or workmanship, repairs will be made at a reasonable charge, which charges may include the costs of parts, labor, and transportation.

THIS WARRANTY IS EXCLUSIVE, AND IS IN LIEU OF ANY OTHER WARRANTIES, EXPRESS OR IMPLIED, INCLUDING BUT NOT LIMITED TO WARRANTY OF MERCHANTABILITY OR WARRANTY OF FITNESS FOR A PARTICULAR PURPOSE.

Graco's sole obligation and buyer's sole remedy for any breach of warranty shall be as set forth above. The buyer agrees that no other remedy (including, but not limited to, incidental or consequential damages for lost profits, lost sales, injury to person or property, or any other incidental or consequential loss) shall be available. Any action for breach of warranty must be brought within two (2) years of the date of sale.

GRACO MAKES NO WARRANTY, AND DISCLAIMS ALL IMPLIED WARRANTIES OF MERCHANTABILITY AND FITNESS FOR A PARTICULAR PURPOSE, IN CONNECTION WITH ACCESSORIES, EQUIPMENT, MATERIALS OR COMPONENTS SOLD BUT NOT MANUFACTURED BY GRACO. These items sold, but not manufactured by Graco (such as electric motors, switches, hose, etc.), are subject to the warranty, if any, of their manufacturer. Graco will provide purchaser with reasonable assistance in making any claim for breach of these warranties.

In no event will Graco be liable for indirect, incidental, special or consequential damages resulting from Graco supplying equipment hereunder, or the furnishing, performance, or use of any products or other goods sold hereto, whether due to a breach of contract, breach of warranty, the negligence of Graco, or otherwise.

FOR GRACO CANADA CUSTOMERS

The Parties acknowledge that they have required that the present document, as well as all documents, notices and legal proceedings entered into, given or instituted pursuant hereto or relating directly or indirectly hereto, be drawn up in English. Les parties reconnaissent avoir convenu que la rédaction du présente document sera en Anglais, ainsi que tous documents, avis et procédures judiciaires exécutés, donnés ou intentés, à la suite de ou en rapport, directement ou indirectement, avec les procédures concernées.

Graco Information

For the latest information about Graco products, visit www.graco.com.

TO PLACE AN ORDER, contact your Graco distributor or call to identify the nearest distributor.

Phone: 612-623-6928 or **Toll Free:** 1-800-533-9655, **Fax:** 612-378-3590.

*All written and visual data contained in this document reflects the latest product information available at the time of publication.
Graco reserves the right to make changes at any time without notice.*

For patent information, see www.graco.com/patents.

Original instructions. This manual contains English. MM 308426

Graco Headquarters: Minneapolis
International Offices: Belgium, China, Japan, Korea

GRACO INC. AND SUBSIDIARIES • P.O. BOX 1441 • MINNEAPOLIS MN 55440-1441 • USA

Copyright 1995, Graco Inc. All Graco manufacturing locations are registered to ISO 9001.

www.graco.com

Revised December 2012