



INSTRUCTIONS

This manual contains important warnings and information.
READ AND KEEP FOR REFERENCE.

First choice when quality counts.™

LOW PRESSURE, HIGH VOLUME

HIGH-FLO® Pumps

NOTE: Stainless Steel Pumps are Severe-Duty and Electropolished, for use with Water-Base Coatings

For Pump Part Nos., Ratios, and Working Pressures, refer to pages 4 and 5.

Table of Contents

Symbols	2
Warnings	2
Pump Models	4
Installation	6
Operation	14
Maintenance	17
Troubleshooting	18
Service	19
Pump Parts	29
Displacement Pump Parts	34
Repair and Conversion Kits	45
Technical Data	46
Dimensions	59
Mounting Stand Hole Layout	59
Warranty	60
Graco Phone Number	60

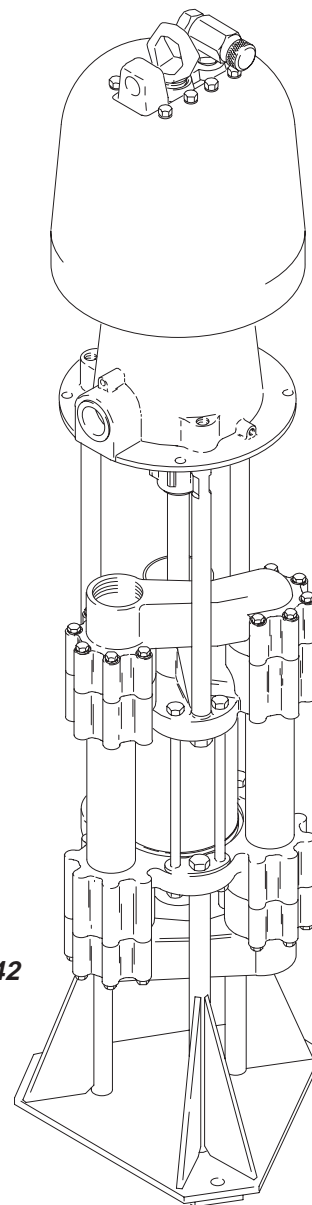

*Stainless Steel Model Shown,
Mounted on Accessory Stand 218742*



01405

Symbols

Warning Symbol



This symbol alerts you to the possibility of serious injury or death if you do not follow the instructions.

Caution Symbol



This symbol alerts you to the possibility of damage to or destruction of equipment if you do not follow the instructions.

WARNING



INSTRUCTIONS

EQUIPMENT MISUSE HAZARD

Equipment misuse can cause the equipment to rupture or malfunction and result in serious injury.

- This equipment is for professional use only.
- Read all instruction manuals, tags, and labels before operating the equipment.
- Use the equipment only for its intended purpose. If you are uncertain about usage, call your Graco distributor.
- Do not alter or modify this equipment. Use only genuine Graco parts and accessories.
- Check equipment daily. Repair or replace worn or damaged parts immediately.
- Do not exceed the maximum working pressure stated on the equipment or in the **Technical Data** for your equipment. Do not exceed the maximum working pressure of the lowest rated component in your system.
- Use fluids and solvents which are compatible with the equipment wetted parts. Refer to the **Technical Data** section of all equipment manuals. Read the fluid and solvent manufacturer's warnings.
- Do not use hoses to pull equipment.
- Route hoses away from traffic areas, sharp edges, moving parts, and hot surfaces. Do not expose Graco hoses to temperatures above 82°C (180°F) or below -40°C (-40°F).
- Wear hearing protection when operating this equipment.
- Do not lift pressurized equipment.
- Comply with all applicable local, state, and national fire, electrical, and safety regulations.

WARNING



FIRE AND EXPLOSION HAZARD

Improper grounding, poor ventilation, open flames or sparks can cause a hazardous condition and result in a fire or explosion and serious injury.

- Ground the equipment and the object being sprayed. Refer to **Grounding** on page 6.
- If there is any static sparking or you feel an electric shock while using this equipment, **stop spraying/dispensing immediately**. Do not use the equipment until you identify and correct the problem.
- Provide fresh air ventilation to avoid the buildup of flammable fumes from solvents or the fluid being sprayed/dispensed.
- Keep the spray/dispense area free of debris, including solvent, rags, and gasoline.
- Electrically disconnect all equipment in the spray/dispense area.
- Extinguish all open flames or pilot lights in the spray/dispense area.
- Do not smoke in the spray/dispense area.
- Do not turn on or off any light switch in the spray/dispense area while operating or if fumes are present.
- Do not operate a gasoline engine in the spray/dispense area.



TOXIC FLUID HAZARD

Hazardous fluid or toxic fumes can cause serious injury or death if splashed in the eyes or on the skin, inhaled, or swallowed.

- Know the specific hazards of the fluid you are using.
- Store hazardous fluid in an approved container. Dispose of hazardous fluid according to all local, state and national guidelines.
- Always wear protective eyewear, gloves, clothing and respirator as recommended by the fluid and solvent manufacturer.



MOVING PARTS HAZARD

Moving parts, such as the air motor piston, can pinch or amputate your fingers.

- Keep clear of all moving parts when starting or operating the pump.
- Before servicing the equipment, follow the **Pressure Relief Procedure** on page 14 to prevent the equipment from starting unexpectedly.

Pump Models

NOTE: To mount a High-Flo displacement pump on a Senator air motor, refer to page 32.

CARBON STEEL MODELS

Pump Part No.	Series	Ratio and Type (parts list pages)	Displacement Pump, Series (parts list pages)	Maximum Air (or Hydraulic*) Working Pressure	Maximum Fluid Working Pressure
				MPa, bar (psi)	MPa, bar (psi)
218511	B	3:1 Bulldog (29)	218515, Series J (34)	0.7, 7.0 (100)	2.1, 21 (300)
218519	B	2:1 Bulldog (29)	218523, Series J (36)	0.7, 7.0 (100)	1.4, 14 (200)
218526	B	1.5:1 Bulldog (29)	218530, Series J (38)	0.7, 7.0 (100)	1.0, 10 (150)
218513	C	6:1 King (30)	218515, Series J (34)	0.6, 6.2, (90)	3.7, 37 (540)
218521	C	4:1 King (30)	218523, Series J (36)	0.6, 6.2, (90)	2.5, 25 (360)
218528	C	3:1 King (30)	218530, Series J (38)	0.6, 6.2, (90)	1.9, 19 (270)
218533	D	Viscount II 600 (33)	218515, Series J (34)	10.3*, 103* (1500*)	4.1, 41 (600)
218535	D	Viscount II 400 (33)	218523, Series J (36)	10.3*, 103* (1500*)	2.8, 28 (400)
218537	D	Viscount II 300 (33)	218530, Series J (38)	10.3*, 103* (1500*)	2.1, 21 (300)

Pump Models

NOTE: To mount a High-Flo displacement pump on a Senator air motor, refer to page 32.

SEVERE-DUTY ELECTROPOLISHED STAINLESS STEEL MODELS

Pump Part No.	Series	Ratio and Type (parts list pages)	Displacement Pump, Series (parts list pages)	Maximum Air (or Hydraulic*) Working Pressure	Maximum Fluid Working Pressure
				MPa, bar (psi)	MPa, bar (psi)
218512	C	3:1 Bulldog (29)	218516, Series L (34)	0.7, 7.0 (100)	2.1, 21 (300)
218520	C	2:1 Bulldog (29)	218524, Series L (36)	0.7, 7.0 (100)	1.4, 14 (200)
218527	C	1.5:1 Bulldog (29)	218531, Series L (38)	0.7, 7.0 (100)	1.0, 10 (150)
218514	D	6:1 King (30)	218516, Series L (34)	0.6, 6.2, (90)	3.7, 37 (540)
218522	D	4:1 King (30)	218524, Series L (36)	0.6, 6.2, (90)	2.5, 25 (360)
218529	D	3:1 King (30)	218531, Series L (38)	0.6, 6.2, (90)	1.9, 19 (270)
218534	E	Viscount II 600 (33)	218516, Series L (34)	10.3*, 103* (1500*)	4.1, 41 (600)
218536	E	Viscount II 400 (33)	218524, Series L (36)	10.3*, 103* (1500*)	2.8, 28 (400)
218538	E	Viscount II 300 (33)	218531, Series L (38)	10.3*, 103* (1500*)	2.1, 21 (300)

SEVERE-DUTY ELECTROPOLISHED STAINLESS STEEL MODELS, WITH BSP THREADS

Pump Part No.	Series	Ratio and Type (parts list pages)	Displacement Pump, Series (parts list pages)	Maximum Air Working Pressure	Maximum Fluid Working Pressure
				MPa, bar (psi)	MPa, bar (psi)
240601	A	4:1 King (30)	240592, Series A , with tri-clamp adapters (40)	0.6, 6.2, (90)	2.5, 25 (360)
240602	A	4:1 King (30)	240593, Series A, without tri-clamp adapters (40)	0.6, 6.2, (90)	2.5, 25 (360)
240598	A	3:1 King (30)	240589, Series A , with tri-clamp adapters (40)	0.6, 6.2, (90)	1.9, 19 (270)
240599	A	3:1 King (30)	240590, Series A, without tri-clamp adapters (40)	0.6, 6.2, (90)	1.9, 19 (270)

NOTE: High-Flo displacement pumps 240595 (with tri-clamp adapters) and 240596 (without tri-clamp adapters) are available as options. See page 42 for parts.

Installation

Grounding

⚠ WARNING



FIRE AND EXPLOSION HAZARD

Before operating the pump, ground the system as explained below. Also read the section **FIRE AND EXPLOSION HAZARD** on page 3.



1. *Pump*: use a ground wire and clamp. See Fig. 1. Loosen the grounding lug locknut (W) and washer (X). Insert one end of a 1.5 mm² (12 ga) minimum ground wire (Y) into the slot in lug (Z) and tighten the locknut securely. Connect the other end of the wire to a true earth ground. Order Part No. 237569 Ground Wire and Clamp.

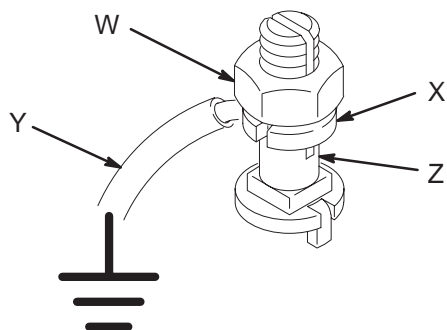

0864

Fig. 1

2. *Air and fluid hoses*: use only electrically conductive hoses.
3. *Air compressor or hydraulic power supply*: follow manufacturer's recommendations.
4. *Surge tank*: use a ground wire and clamp. See Fig. 1.
5. *Spray gun*: ground through connection to a properly grounded fluid hose and pump.
6. *Fluid supply container*: follow your local code.
7. *Object being sprayed*: follow your local code.
8. *Solvent pails used when flushing*: follow your local code. Use only metal pails, which are conductive, placed on a grounded surface. Do not place the pail on a nonconductive surface, such as paper or cardboard, which interrupts the grounding continuity.

9. *To maintain grounding continuity when flushing or relieving pressure*, hold a metal part of the spray gun firmly to the side of a grounded *metal* pail, then trigger the gun.

Plumbing

Most displacement pump models have a 2 in. npt(f) fluid inlet and a 2 in. npt(f) fluid outlet. Models 240589, 240590, 240592, 240593, 240595, and 240596 have a 2 in. bsp(f) fluid inlet and a 2 in. bsp(f) fluid outlet.

Use 50 mm (2 in.) diameter pipe and plumbing. Install a fluid shutoff valve (D) between each tank and the pump.

When using a stainless steel pump, use stainless steel plumbing to maintain a corrosion-resistant system.

Pumps With Tri-Clamp Adapters

Displacement Pumps 240589, 240592, and 240595 include tri-clamp adapters which allow sanitary pipe to be connected to the pump inlet and outlet. Refer to Fig. 2.

Install a 2 in. tri-clamp gasket (GG, not supplied) in the groove of the tri-clamp adapter (50). Mate the tri-clamp adapter with the sanitary pipe and secure with two clamps (HH), bolts (JJ), and nuts (KK) (not supplied). Install the bolts in opposite directions.

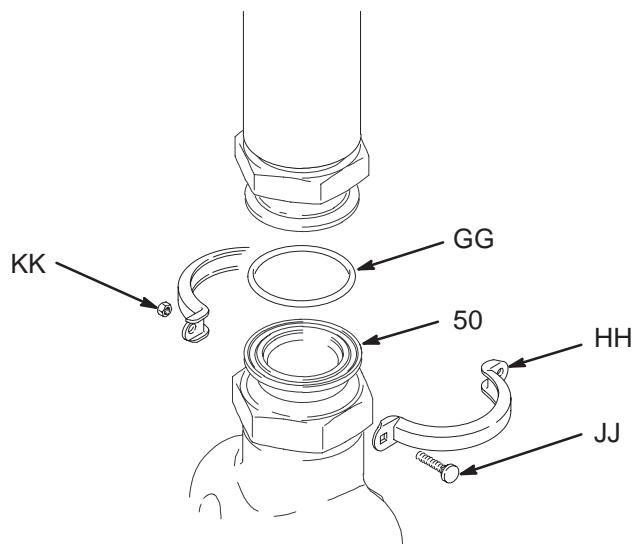

8689A

Fig. 2

Installation

All Systems

NOTE: Reference numbers and letters in parentheses in the text refer to the callouts in the figures and parts drawings.

The Typical Installations shown in Figs. 4 and 5 are only examples. Contact your Graco distributor for system design assistance.

An accessory surge tank (B), Part No. 218509 (cst) or 218510 (sst) should be used to reduce fluid surging and to prevent backflow into the pump. Install a full flow, non-restrictive fluid shutoff valve (D) before and after the surge tank to isolate it for servicing. The surge tank also uses the accessory stand (218742).

⚠ WARNING

COMPONENT RUPTURE HAZARD

 To reduce the risk of component rupture, which can cause serious injury, be sure that all accessories and system components can withstand the pressure and flow in this system.

Mount the Pump

Mount the pump in the accessory pump stand (A), Part No. 218742. Secure the stand to the floor with M19 (5/8 in.) bolts which engage at least 152 mm (6 in.) into the concrete floor to prevent the pump from tipping.

Non-Circulating Systems

In non-circulating systems with a fluid outlet that can be closed off (causing the pump to stall), install a fluid pressure relief valve (AA) and a return line (BB). See Fig. 3.

⚠ WARNING

COMPONENT RUPTURE HAZARD

 The pressure relief valve reduces the risk of the pump overpressurizing if the piston seal is worn and leaking, and the fluid outlet is closed off. Install the valve so the arrow on its body matches the direction of fluid flow.

Do not install a fluid shutoff valve in the fluid line between the pump outlet (DD) and the pump inlet (CC). Doing so defeats the purpose of the pressure relief valve if the shutoff valve is closed, resulting in pump overpressurization. Overpressurization can cause the pump or components to rupture, resulting in serious injury and property damage.

Pressure Relief Valve (for non-circulating systems)

KEY

- A Accessory Pump Stand (P/N 218742)
- C 50 mm (2 in.) Diameter Pipe
- D Full Flow, Non-Restrictive Fluid Shutoff Valve
- E Fluid Supply Line
- AA External Pressure Relief Valve
- BB Fluid Return Line
- CC Pump Fluid Inlet
- DD Pump Fluid Outlet

1 Do not install a fluid shutoff valve in the fluid line between the pump outlet (DD) and the pump inlet (CC). See the **WARNING** above.

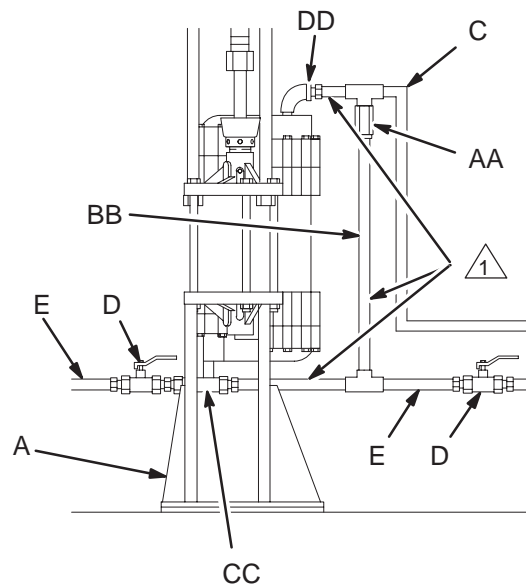

Fig. 3

01407

Installation (Air-Powered Pumps)

WARNING

A bleed-type master air valve (L) is required in your system, to help reduce the risk of serious injury including splashing fluid in the eyes or on the skin, and injury from moving parts if you are adjusting or repairing the pump.

The bleed-type master air valve relieves air trapped between this valve and the pump after the air is shut off. Trapped air can cause the pump to cycle unexpectedly. Locate the valve close to the pump.

CAUTION

Do not hang the air accessories directly on the pump's air inlet. The fittings are not strong enough to support the accessories and may cause one or more to break. Provide a bracket on which to mount the accessories.

In an air-powered system, install the air line accessories in the order shown in Fig. 4. Working upstream from the pump air inlet, install an air line lubricator (H) for automatic air motor lubrication. Next, install a bleed-type master air valve (L) to relieve air trapped between the valve and the pump, and an air regulator and gauge (J) to control pump speed.

Install a pump runaway valve (G) to shut off the air to the pump if the pump accelerates beyond the pre-adjusted setting. A pump which runs too fast can be seriously damaged.

Install an air filter (K) to remove harmful dirt and moisture from the compressed air supply, and a second bleed-type master air valve to isolate the air line accessories for servicing. Last, install a drain valve (W) at the bottom of each air line drop, to drain off moisture.

Installation (Air-Powered Pumps)

KEY

- A Accessory Pump Stand (P/N 218742)
- B Surge Tank (P/N 218509 or 218510)
- C 50 mm (2 in.) Diameter Pipe
- D Full Flow, Non-Restrictive Fluid Shutoff Valve
- E Fluid Supply Line
- F Mix Tank
- G Pump Runaway Control Valve
- H Air Line Lubricator
- J Air Regulator and Gauge
- K Air Line Filter
- L Bleed-type Master Air Valve
- W Air Line Drain Valve
- Y Ground Wire



Do not hang the air accessories directly on the pump's air inlet. Provide a bracket on which to mount the accessories.

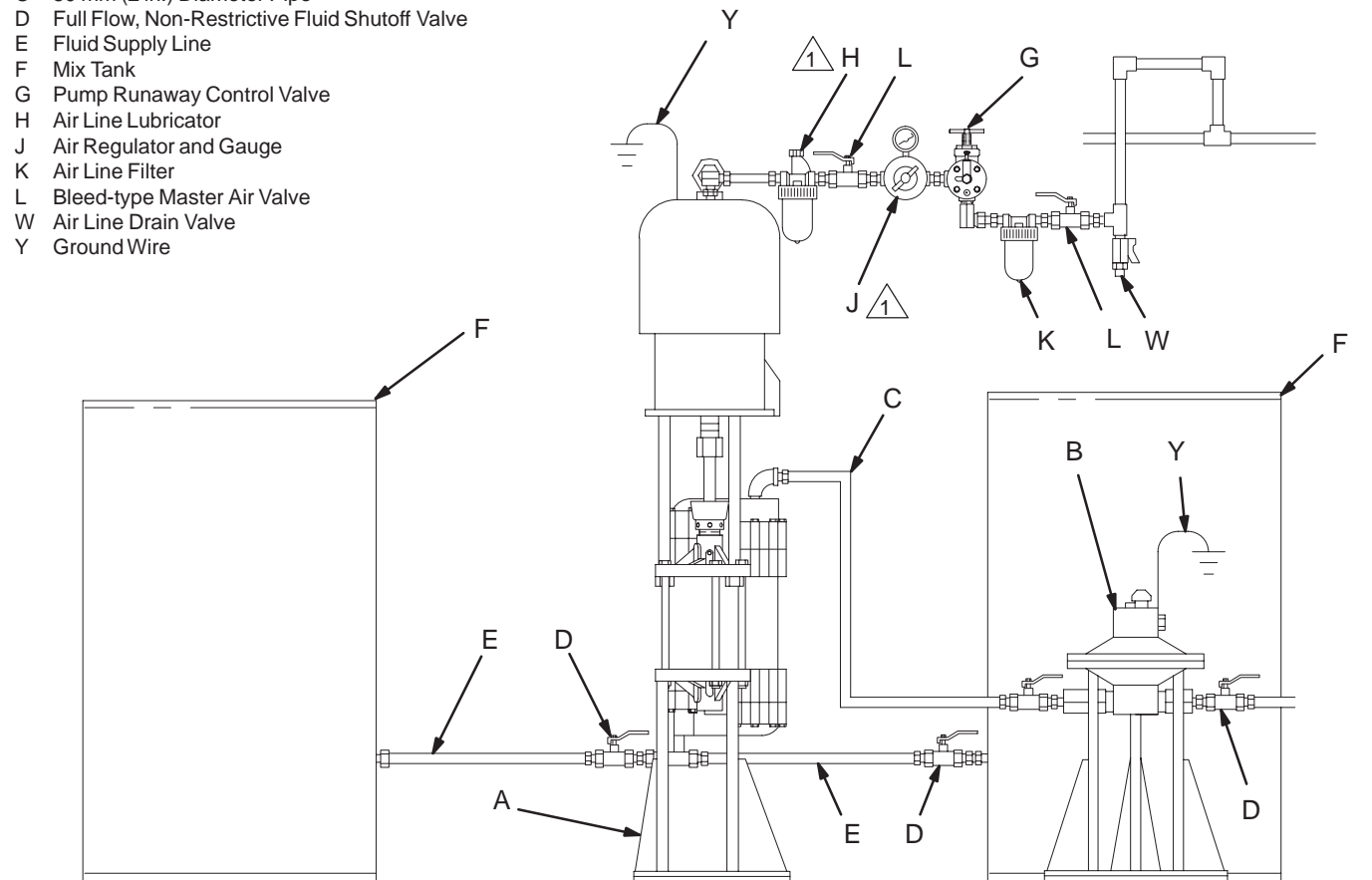

Fig. 4

01406

Installation (Hydraulic-Powered Pumps)

CAUTION

The Hydraulic Power Supply must be kept clean at all times to avoid damage to the motor and hydraulic power supply.

1. Blow out hydraulic lines with air and flush thoroughly before connection to the motor.
2. Plug hydraulic inlets, outlets, and line ends when disconnecting them for any reason.

Always plug the hydraulic inlets, outlets and lines when disconnecting them for any reason to avoid introducing dirt and other contaminants into the system.

Be sure that your hydraulic power supply is equipped with a suction filter to the hydraulic pump and a system return line filter of 10 micron size. Carefully follow the manufacturer's recommendations on reservoir and filter cleaning and periodic changes of hydraulic fluid.

The motor has a 3/4 npt hydraulic oil inlet, and a 1 in. npt hydraulic oil outlet. Use a minimum 1/2 in. ID hydraulic supply line and a minimum 5/8 in. ID return line.

On the hydraulic oil supply line (P), install a shutoff valve (G) to isolate the system for servicing; a fluid pressure gauge (H) to monitor hydraulic oil pressure to the motor and avoid overpressurizing the motor or displacement pump; a pressure- and temperature-compensated flow control valve (J) to prevent the motor from running too fast; a pressure reducing valve (K) with a drain line (L) running directly into the hydraulic return line (Q); and an accumulator (N) to reduce the hammering effect caused by the motor reversing direction.

On the hydraulic return line (Q), install a shutoff valve (M) for isolating the motor for servicing.

Installation (Hydraulic-Powered Pumps)

KEY

- | | | | |
|---|---|---|--------------------------|
| A | Accessory Pump Stand
(P/N 218742) | H | Hydraulic Pressure Gauge |
| B | Surge Tank (P/N 218509 or
218510) | J | Flow Control Valve |
| C | 50 mm (2 in.) Diameter Pipe | K | Pressure Reducing Valve |
| D | Full Flow, Non-Restrictive
Fluid Shutoff Valve | L | Drain Line |
| E | Fluid Supply Line | M | Hydraulic Return Line |
| F | Mix Tank | N | Accumulator |
| G | Hydraulic Supply Line
Shutoff Valve | P | Hydraulic Supply Line |
| | | Q | Hydraulic Return Line |
| | | Y | Ground Wire |

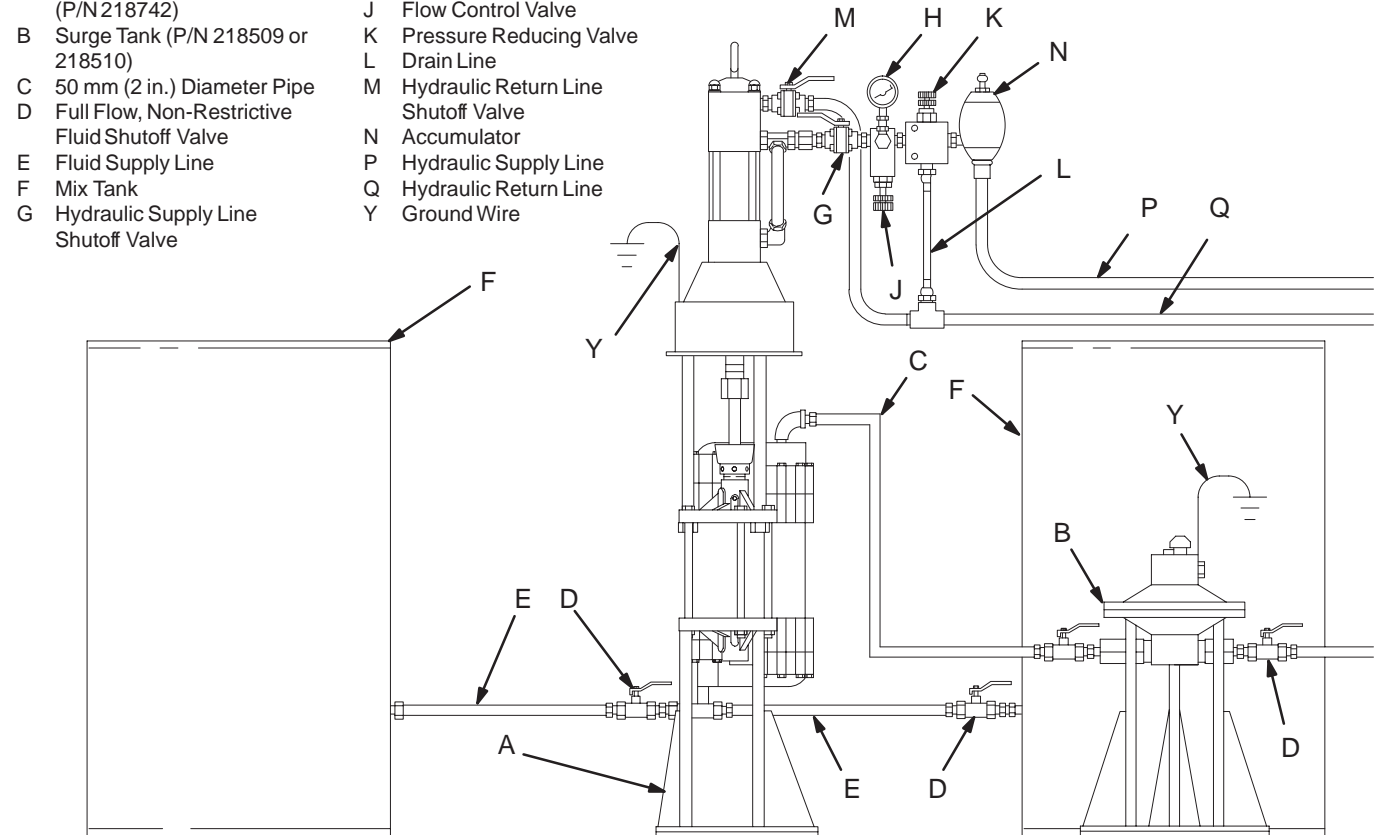

Fig. 5

01408

Installation (Solvent Flush Feature)

The throat area of a pump usually wears faster than other pump parts due to contaminants drawn in by the pumping action of the piston rod and abrasive particles in the fluid. To reduce wear and prolong pump life, this pump can be connected to a solvent flush system for constant flushing of the throat area.

Use of a solvent flush system requires installation of two o-rings in the throat. Refer to the appropriate packing nut detail in Fig. 6. Note that the stainless steel packing nut is different from the carbon steel packing nut. Install an ARP Size 214 o-ring in groove (U) inside the packing nut (33). Install a Size 127 o-ring in the groove (V) on the outside of the packing nut.

CAUTION

Be sure that the o-ring material is compatible with the solvent you are using, to prevent damage to the o-rings. To determine compatibility, call your Graco distributor.

NOTE: Graco offers Viton® o-rings, P/N 107550 and 107571, which are compatible in many applications. Order them separately. Install 107550 at position V and 107571 at position U (see Fig. 6).

NOTE: For stainless steel models, Graco offers an accessory wiper seal kit, P/N 237766, to reduce leakage of TSL from the wet-cup into the throat area. Install in the first groove (X) of the packing nut (33). The kit includes instructions.

The solvent enters the pump throat through a small port, swirls around the piston rod, and exits through another port, carrying away most abrasive particles and contaminants. Seals in the throat prevent the solvent from leaking into the cylinder or up through the packing nut.

Fig. 6 shows a basic installation of a solvent flush system. Your system will depend on the variables of your High-Flo pump installation. For design assistance, contact your Graco distributor.

The minimum solvent flow required for each High-Flo pump is 1.9 liter/min (0.5 gpm) at a maximum of 0.7 MPa, 7 bar (100 psi) fluid pressure.

Installation (Solvent Flush Feature)

*Top View of Displacement Pump
(Stainless Steel Pump Shown)*

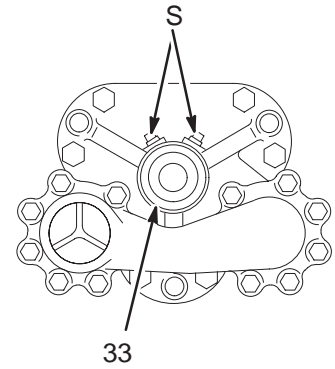

01410

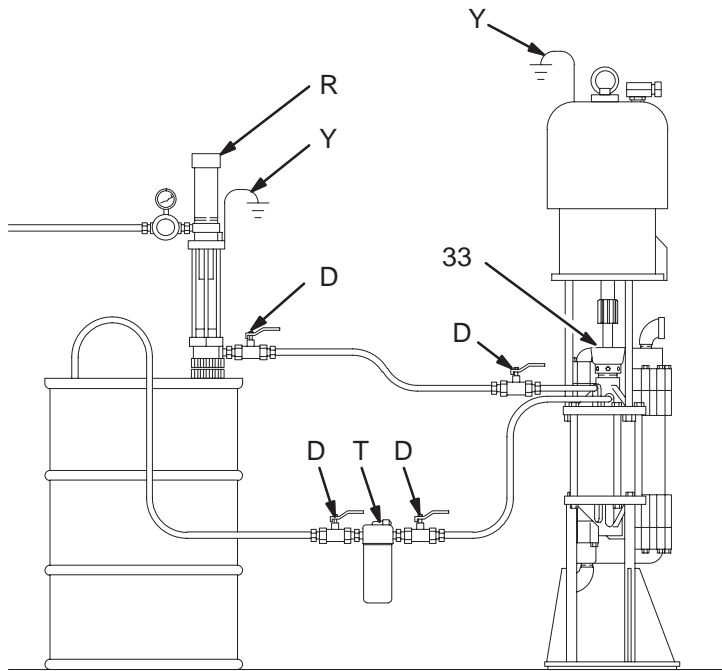

KEY

- D Full Flow, Non-Restrictive Fluid Shutoff Valve
- R Solvent Supply Pump
- S 1/8 npt(f) Solvent Flush Ports
- T Return Line Filter (10 micron filter, minimum)
- U Size 214 O-Ring position
- V Size 127 O-Ring position
- X Wiper Seal Kit position (Stainless Steel Pumps only)
- Y Ground Wire
- 33 Packing Nut

01409

*Installing O-Rings and Wiper Seal on
Packing Nut (Stainless Steel Pumps)*

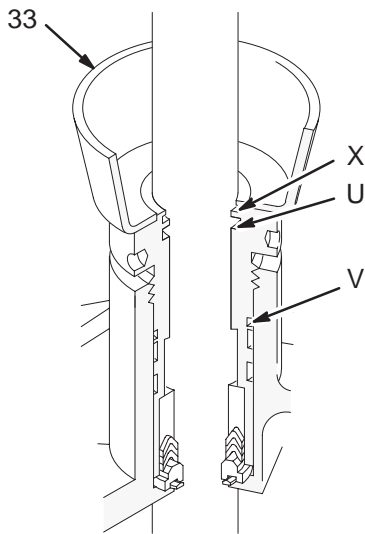

01416

*Installing O-Rings on Packing Nut
(Carbon Steel Pumps)*

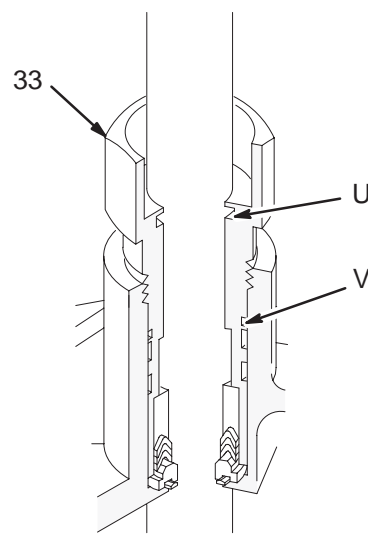

05091

Fig. 6

Operation

Pressure Relief Procedure

WARNING

PRESSURIZED EQUIPMENT HAZARD

The system pressure must be manually relieved to prevent the system from starting or spraying accidentally. To reduce the risk of an injury from accidental spray from the gun, splashing fluid, or moving parts, follow the **Pressure Relief Procedure** whenever you:

- are instructed to relieve the pressure,
- stop spraying,
- check or service any of the system equipment,
- or install or clean the spray nozzle.

1. Shut off the power to the pump.
2. **In an air-powered system**, close the air regulator (J) and close the bleed-type master air valve (L).
3. **In a hydraulic-powered system**, close the hydraulic supply line shutoff valve (G) first, then the return line shutoff valve (M).
4. Close the fluid shutoff valves from the supply tanks.
5. Open the dispensing valve, if used, or slowly and carefully loosen a fluid fitting near the pump to relieve pressure.

Flush the Pump

Flush the pump before using it the first time to remove the lightweight oil which was left in the pump after factory testing to protect it from corrosion. Flush with a compatible solvent until your pump and lines are thoroughly cleaned. Follow the **Pressure Relief Procedure** at left and remove the spray tip before flushing. Hold a metal part of the gun firmly to the side of a grounded metal pail, and always use the lowest possible pressure when flushing.

Operation

Starting and Adjusting the Pump

1. Fill the wet-cup/packing nut (33) one half full with Graco Throat Seal Liquid (TSL). See Fig. 7.
2. Charge the surge tank, if you are using one. See the separate instruction manual, 307707.
3. Open the shutoff valves between the pump and supply tanks, and between the pump and surge tank.
4. Open the dispensing valve(s) or spray gun(s).
5. To adjust the system, perform the following applicable procedure:

In an air-powered system:

- a. Open the bleed-type master air valve.
- b. Adjust the air regulator to the minimum pressure necessary for the pump to cycle slowly.
- c. Operate the pump slowly until all air is purged from the fluid lines.
- d. Close the gun or valve.
- e. Adjust the setting on the pump runaway valve, if used.

In a hydraulic-powered system:

- a. Turn on the hydraulic power supply.
- b. Open the flow control valve all the way.

- c. Adjust the pressure-reducing valve until you get the desired fluid pressure. Run the pump until all air is purged from the fluid lines.
- d. Count the cycle rate of the pump.
- e. Close the flow control valve until the cycle rate and fluid pressure start to drop.
- f. Open the flow control valve slightly until the cycle rate and fluid pressure return to the desired level. This method of setting the hydraulic controls ensures proper pump operation and will prevent pump runaway and damage if the fluid supply runs out.
- g. Close the gun or valve.

In a circulating system, the pump operates continuously until the power supply is shut off. ***In a direct supply system***, the pump starts when the gun or valve is opened, and stops when the gun or valve is closed.

WARNING

COMPONENT RUPTURE HAZARD



To reduce the risk of serious injury, including splashing in the eyes or on the skin, and property damage, never exceed the maximum air/hydraulic and fluid working pressure of the lowest rated component in your system. See **EQUIPMENT MISUSE HAZARD, System Pressure**, on page 3.

Maintenance

Care of the Pump

WARNING

To reduce the risk of serious injury whenever you are instructed to relieve pressure, always follow the **Pressure Relief Procedure** on page 14.

Check the tightness of the packing nut (33) weekly. Shut off the pump and relieve pressure before checking the packing nut. The nut should be tight enough to stop leakage, about 27–34 N.m (20–25 ft-lb). Over-tightening will compress and damage the packings and cause the pump to leak.

Always flush the pump before any fluid can dry in it. Always stop the pump at the bottom of its stroke to prevent the fluid from drying on the piston rod and damaging the throat packings.

Read all other instruction manuals supplied with your pump and with all accessories you add to the system.

Monitor the fluid supply carefully. If air is sucked into the pump due to an empty supply container, the pump will accelerate quickly and can damage the pump packings. If your pump begins running too fast, shut it off immediately. Refill the supply container and prime the pump to remove all air from the fluid line. In an air-powered system, the accessory pump runaway valve automatically senses when a pump is running too fast and shuts off the air to stop the pump.

Stainless Steel Model

 Torque to 27–34 N.m (20–25 ft-lb).

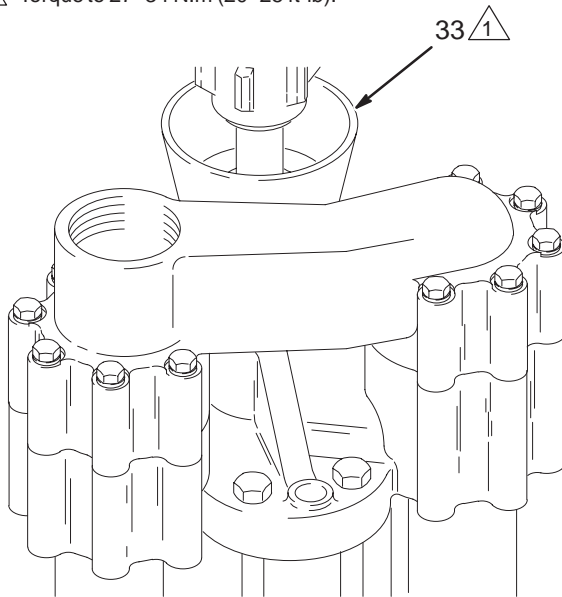

Carbon Steel Model

 Torque to 27–34 N.m (20–25 ft-lb).

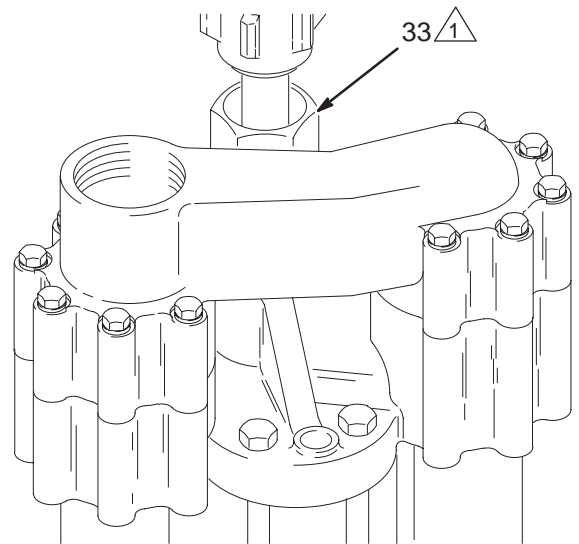

Fig. 7

Troubleshooting

PROBLEM	CAUSE	SOLUTION
Pump output low on both strokes	Restricted air or hydraulic lines	Clear any obstructions; be sure all valves are open; increase pressure.
	Empty fluid supply	Refill and reprime pump. In an air-powered system, use pump runaway valve.
	Clogged fluid outlet line, valves, etc.	Clear.
	Worn packings	Tighten packing nut; replace all packings.
Pump output low on only one stroke	Held open or worn check valve	Check and repair.
	Worn piston packings	Replace.
No output	Improperly installed ball check valves	Check and correct; see page 25, starting at step 26.
Pump operates erratically	Exhausted fluid supply	Refill and reprime pump. In an air-powered system, use pump runaway valve.
	Held open or worn check valves	Check and repair.
	Worn piston packings	Replace.
	Excessive hydraulic fluid supply pressure to Viscount motor	See hydraulic motor manual, 308048.
Pump does not operate	Restricted air or hydraulic power supply lines	Clear any obstructions; be sure all shut-off valves are open; increase pressure.
	Exhausted fluid supply	Refill and reprime pump.
	Clogged fluid outlet line, valves, etc.	Clear.
	Damaged air motor or hydraulic motor	See motor manual.
	Fluid dried on piston rod	Disassemble and clean pump. Stop pump at bottom of stroke.

Service

To Remove the Motor (See Fig. 8)

⚠ WARNING

To reduce the risk of serious injury whenever you are instructed to relieve pressure, always follow the **Pressure Relief Procedure** on page 14.

1. Relieve the pressure.
2. Disconnect all hoses from the pump and motor.
3. Unscrew the coupling nut (106), holding your hand around the nut and shaft to catch the two couplers (105) as you lower the nut (106).
4. Remove the tie rod locknuts (104) and lift the motor off the pump.

To Reattach the Motor (See Fig. 8)

⚠ CAUTION

On *stainless steel pumps*, be sure to lubricate the threads of the tie rods **and** apply PTFE tape to the bottom threads of the rods before reattaching the air motor. The bottom threads are farthest from the tie rod flats.

1. Position the air motor on the pump. On stainless steel pumps, lubricate and tape the tie rod threads (see the **CAUTION** above). Screw the tie rod locknuts (104) onto the tie rods (103).
2. Place the two couplers (105) in the coupling nut (106). Screw the nut up onto the motor shaft. Torque to 195–210 N.m (145–155 ft-lb).

⚠ CAUTION

Torque the coupling nut (106) to 195–210 N.m (145–155 ft-lb). **Do not** exceed this torque specification, to prevent damage to the piston shaft (32).

3. Reconnect all hoses. Reconnect the groundwire if it was disconnected.

Stainless Steel Model Shown

- 1 **⚠** Torque to 195–210 N.m (145–155 ft-lb).
- 2 **⚠** Stainless Steel Models: Lubricate tie rod threads.
- 3 **⚠** Stainless Steel Models: Apply PTFE tape to bottom threads.

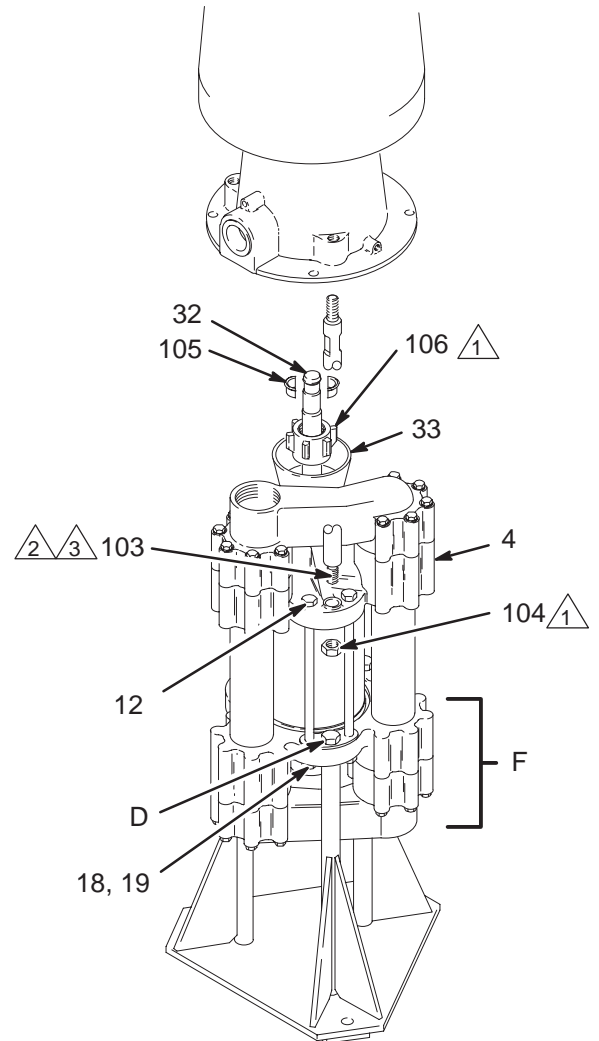

Fig. 8

01412

Service

NOTES:

1. This repair procedure can be used for any High-Flo pump model. The reference numbers used in the text and illustrations correspond to all of the displacement pump parts drawings.
2. Packing repair kits are available for each pump. Refer to the parts pages for your pump. Parts included in the pump seal repair kit are marked with an asterisk in the text (for example, 20*). Parts included in the throat packing kit are marked with a symbol (for example, 39†). Conversion kits are also available. See page 45. Use all the new parts in the kits for the best results.
3. This pump is easiest to repair when left in the Part No. 218742 accessory pump stand and disassembled as instructed. For repair at a remote location, have another pump stand available.
4. A special piston assembly tool is needed. Order part number 180999.
5. When reassembling, apply anti-seize lubricant 222955 on the threads of the piston shaft (32) and piston (24).

2. Lift the manifold (5) off the outlet valve housing (4) and remove the ball guides (23), balls (22), seats (21) and seals (43). Remove the o-ring (20) from the seats (21).

NOTE: Seat Puller Kit 220384 is available to make removal of the seats from the manifolds easier. See Fig. 9.

⚠ CAUTION

Be careful not to drop or damage the balls (22) or seats (21). A damaged ball or seat cannot seal properly and the pump will leak. The outlet valve seats (21) can be reversed to provide longer use of the seat.

3. Remove the nuts (19), lockwashers (18) and six cylinder capscrews (12). Loosen the packing nut (33). Lift off the outlet valve housing (4). See Fig. 8.
4. Lift the riser tubes (14) and cylinder (15) off the inlet valve housing (3). The piston assembly may stay in the cylinder. Remove the seals (13 and 29) from the inlet and outlet housings (3, 4). See Fig. 10.

NOTE: Tap on the valve housings with a plastic mallet and use a slight rocking motion to help loosen and remove the cylinder and tubes.

Displacement Pump Repair

1. Use a 13 mm socket wrench to loosen and remove the twelve capscrews (1) and lockwashers (2) on the outlet manifold (5). See Fig. 10.

Seat Puller Kit 220384

KEY

- S Seat (item 21 or 46)
- X 108481 Bolt
- Y 181630 Seat Puller
- Z 181629 Seat Puller

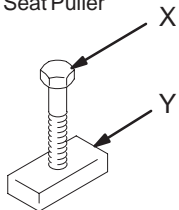

Screw bolt (X) into Seat Puller (Y).

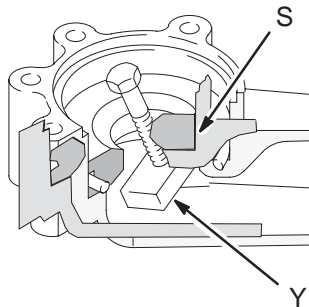

Position Seat Puller (Y) under the seat (21 or 46) by slipping it through at an angle.

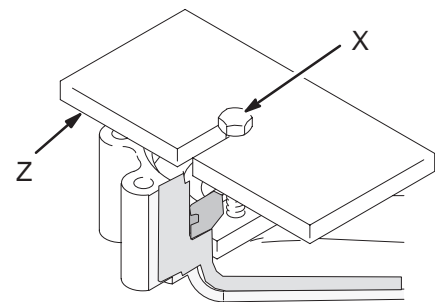

Place Seat Puller (Z) on top of seat. Turn bolt (X) to pull the seat out.

01414

Fig. 9

Service

Stainless Steel Model Shown

1 See Fig. 11.

2 The relief valve seat (46) **must** be installed at the pump fluid inlet. Orient the seat as shown in the Detail. The small ball (B) in the relief valve should point up toward the check ball (22).

3 When installing the relief valve seat (46), install seals (43) and o-rings (20) at the pump fluid inlet **and** on the opposite side of the inlet manifold (5).

4 **Do not** install relief valve seat (46) on this side of the inlet manifold (5).

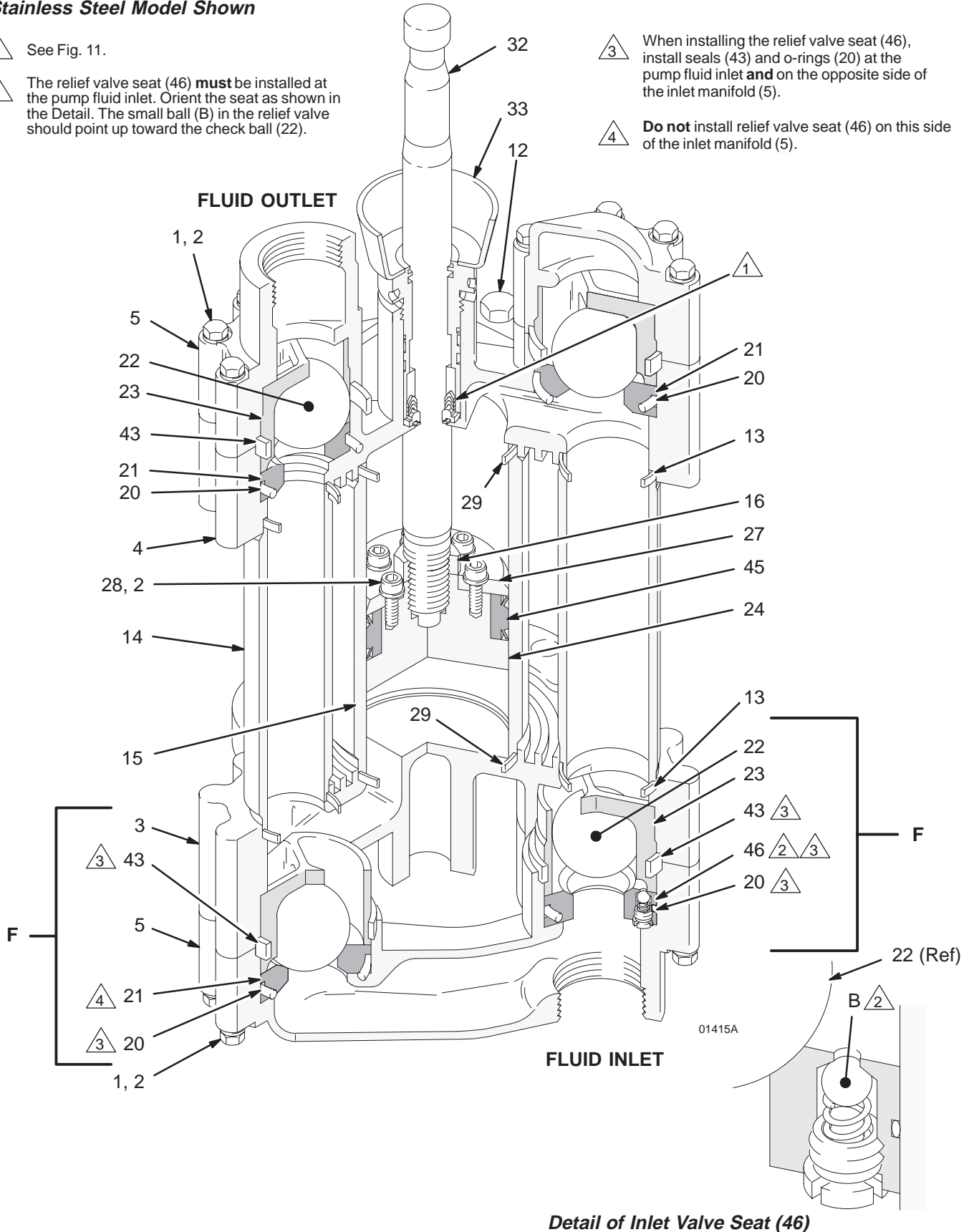

Fig. 10

04944A

Service

5. Screw out the packing nut (33). Remove the packings (40) and female gland (39) from the nut. See Fig. 11.

NOTE: Stainless steel models include a wrench (49) to remove the packing nut.

6. Remove the gland (41) and seal (42) from the cavity of the outlet valve housing (4).

Stainless Steel Model Shown

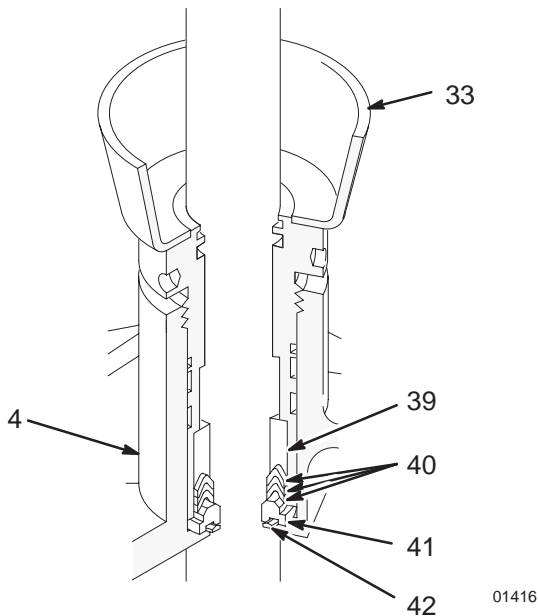

Fig. 11

7. Unscrew and remove the three pump stand bolts (D). See Fig. 8. Lift the inlet valve assembly (F) off the stand. Place the inlet valve housing (3) face down on a protected surface.
8. Use a 13 mm socket wrench to loosen and remove the twelve capscrews (1) and lockwashers (2) from the inlet manifold (5). See Fig. 10.

9. Lift the manifold (5) off the inlet valve housing (3) and remove the seats (21 and 46). Remove the o-ring (20) from the seats.

⚠ CAUTION

If the pressure relief valve in the inlet seat (46) is clogged or filled with material, soak the inlet seat in a compatible solvent. Make sure all material residue is cleaned from the ball and seat area.

If the relief valve cannot be thoroughly cleaned so that the ball and spring are free to move, replace the seat (46).

10. Inspect the pressure relief valve in the fluid inlet seat (46) to make sure it is not clogged. Press down on the valve's ball to see if the ball and spring are free to move. See the detail in Fig. 10.

⚠ CAUTION

Be careful not to drop or damage the balls (22) or seats (21 or 46). A damaged ball or seat cannot seal properly and the pump will leak. One inlet valve seat (21) can be reversed to provide longer use of the seat. However, the fluid inlet seat (46) contains a pressure relief valve and is not reversible. See the detail in Fig. 10 for proper orientation.

11. Remove the balls (22), ball guides (23) and seals (43) from the inlet valve housing (3).
12. Push the piston assembly through the cylinder just enough to expose the piston (24) flats. Secure the piston flats in a vise. Use a plastic mallet to tap the cylinder (15) up and off the piston assembly.

Service

NOTE: Refer to Fig. 12 for Steps 13–17.

13. Remove the screws (28) and lockwashers (2) from the piston plate (27). Loosen the piston nut (16). Use Tool Kit 220385 to remove the piston shaft (32) and piston nut (16). See Fig. 13. Remove the piston nut from the shaft. Remove the plate (27) and the seal (45) from the piston (24).
14. Inspect the piston shaft (32). If it is damaged or the surface is scored, replace it.
15. Clean all piston parts and the cylinder thoroughly in a compatible solvent. Inspect the inner surface of the cylinder for scoring, and replace it if necessary. A scored cylinder will quickly damage the packings.
16. Lubricate the new piston seal (45*) and install it on the piston.
17. Install the piston plate (27) with the beveled edge facing away from the piston seal. Apply medium strength liquid thread adhesive lightly to the piston screws (28) and install two of the screws and lockwashers (2).

1. Torque to 135–149 N.m (100–110 ft-lb).
2. Apply sealant to threads.
3. Apply medium strength thread sealant and torque to 11.5–24.5 N.m (8.5–18 ft-lb).
4. Lubricate.
5. Apply anti-seize lubricant 222955 to the threads of the shaft (32) and piston (24).

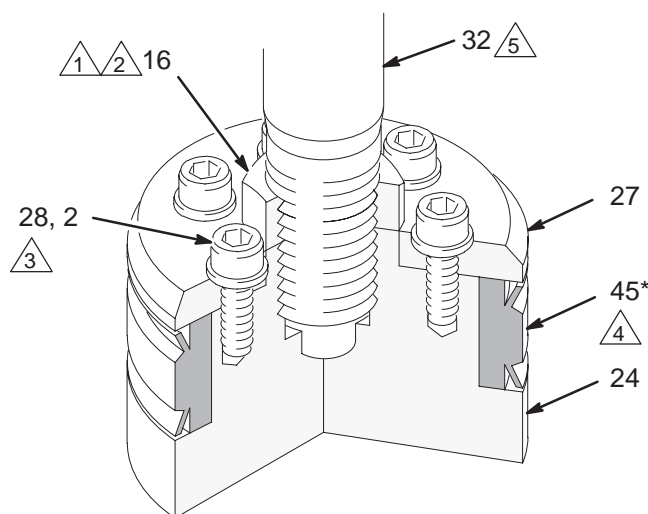

Fig. 12

01417

Tool Kit 220385

Tighten the tool on the widest part of the shaft (32). Grip the tool with a wrench and unscrew the shaft.

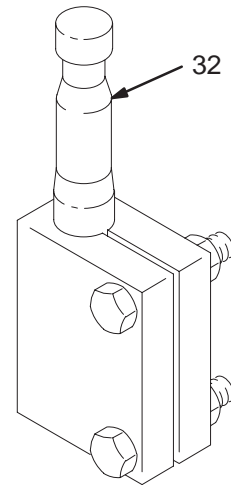

Fig. 13

01413

18. Apply anti-seize lubricant 222955 to the threads of the piston shaft (32) and the piston (24). Screw the shaft tightly into the piston. Install the remaining piston screws (28) and lockwashers (2). Tighten all the screws to 11.5–24.5 N.m (8.5–18 ft-lb). Apply liquid thread adhesive to the piston nut (16) threads, then tighten the nut to 135–149 N.m (100–110 ft-lb).
19. Remove the piston assembly from the vise, but **do not lay it down on its side**.

CAUTION



Do not lay the piston assembly, with the new seal installed, on its side. Doing so may damage the seal.

Service

NOTE: Refer to Fig. 14 for Steps 20 and 21.

 CAUTION
<p>Always use the special assembly tool, part no. 180999, to install the piston assembly in the cylinder. This tool aligns the piston rod properly so it is less likely that the seal will be damaged when installing the piston in the cylinder.</p>

20. Secure the assembly tool in the vise. Position the cylinder (15) in the tool. Insert the piston assembly, piston shaft first, into the cylinder, guiding the shaft through the hole in the tool.
21. Carefully and evenly guide the seal and the piston into the cylinder. Use an arbor press or tap the bottom of the piston assembly lightly with a plastic mallet to slide the piston assembly into the cylinder.
22. Clean the remaining pump parts in a compatible solvent.

-  Do not damage edges of seal (45).
-  Assembly Tool 180999.

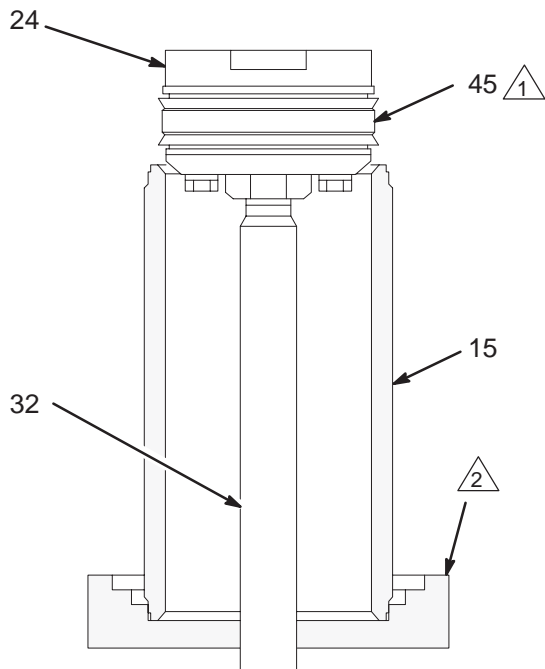



Fig. 14

01418

NOTE: Refer to Fig. 15 for Steps 23 and 24.

23. Lubricate the new throat packings (40†) and female gland (39†) with light grease. Holding the packing nut (33), drop the gland (39†) into the packing nut so that the lips face out. Set the three v-packings (40†) into the packing nut one at a time, with the lips facing out.
24. Lubricate the male gland (41†) well and place a new seal (42†) in the groove of the gland. Set the gland, seal side first, into the top of the outlet valve housing (4).

Stainless Steel Model Shown

-  Install in outlet valve housing (4).
-  Lips of v-packings face down.

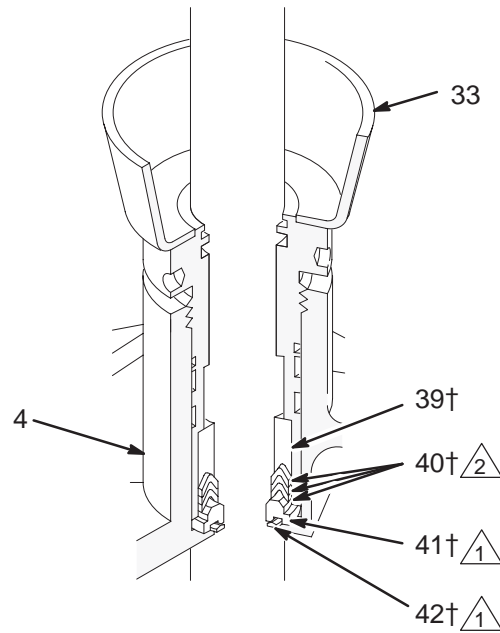

01416

Fig. 15

Service

NOTE: Refer to Fig. 17 for Steps 25–37 unless otherwise indicated.

25. Loosely screw the packing nut (33) into the outlet valve housing (4).
26. Lubricate and install the new o-rings (20*) around each of the four ball seats (21 and 46).

CAUTION

The orientation of the ball valves in the inlet and outlet valve housings is critical. Install the parts of the ball valve exactly as instructed and refer to Fig. 17. If installed incorrectly, the pump will not operate.

27. Place the inlet valve housing (3) on a flat surface with the ball valve openings facing up. Lubricate the seals (43*) and set them into each side of the inlet valve housing.
28. Place the ball guides (23) and balls (22) in the inlet valve housing.

WARNING

COMPONENT RUPTURE HAZARD



The relief valve seat (46) **must** be installed at the fluid inlet, to reduce the risk of pump overpressurization. It cannot relieve pressure if installed in another location.

29. Press the seat (46) with the pressure relief valve into the **fluid inlet side** of the inlet manifold (5). This seat is not reversible. Orient as shown in the detail in Fig. 17. Press the other seat (21), with the unworn side facing out, into the other side of the inlet manifold.

NOTE: The pressure relief seat kit (46) includes two seals (43) and two o-rings (20). When installing a new pressure relief seat, also install the seals and o-rings on **both sides** of the fluid inlet manifold (5).

Service

30. Position the inlet manifold (5) on the inlet valve housing (3). Install the twelve capscrews (1) and lockwashers (2) loosely.
31. Tighten the four inside capscrews oppositely and evenly to 3 N.m (27 in-lb) to balance the load on the valves. Then tighten all twelve capscrews oppositely and evenly to 11.5–24.5 N.m (8.5–18 ft-lb). See Fig. 16.
32. Place the inlet valve housing and manifold assembly on the pump stand. Install and tightly screw in the three pump stand bolts (D). See Fig. 8, page 19.
33. Lubricate and install the new seals (13*, 29*) in the inlet and outlet housings (3, 4). Set the cylinder (15) and riser tubes (14) into place in the inlet valve housing (3). Set the outlet housing (4) onto the cylinder and riser tubes.
34. Install the six cylinder capscrews (12), lockwashers (18) and nuts (19). Tighten the capscrews oppositely and evenly to 81–88 N.m (60–65 ft-lb). See Fig. 16.
35. Lubricate the seals (43*) and press one into each side of the outlet valve housing (4). Press the seats (21), with the unworn sides facing the balls, into the outlet valve housing. Then install the balls (22) and ball guides (23).

36. Place the outlet manifold (5) on the outlet valve housing (4) and install the twelve capscrews (1) and lockwashers (2) loosely. Tighten the inside four capscrews oppositely and evenly to 3 N.m (27 in-lb) to balance the load on the valves. Then tighten all twelve capscrews oppositely and evenly to 11.5–24.5 N.m (8.5–18 ft-lb). See Fig. 16.
37. Tighten the packing nut (33) to 27–34 N.m (20–25 ft-lb).
38. Reconnect the motor as explained on page 19. Be sure the grounding wire is connected.

 Torque oppositely and evenly to 81–88 N.m (60–65 ft-lb).

 Torque these 4 screws oppositely and evenly to 3 N.m (27 in-lb), then tighten all 12 screws oppositely and evenly to 11.5–24.5 N.m (8.5–18 ft-lb).

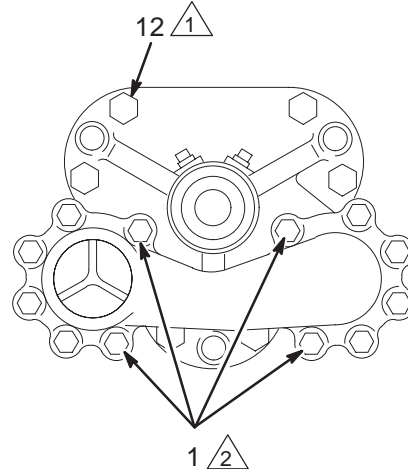

Fig. 16

01410

Service

Stainless Steel Model Shown

- 1 See Fig. 15.
- 2 The relief valve seat (46) **must** be installed at the pump fluid inlet. Orient the seat as shown in the Detail. The small ball (B) in the relief valve should point up toward the check ball (22).
- 3 Torque to 27–34 N.m (20–25 ft-lb).
- 4 Lips of v-packings must face down.
- 5 Apply thread sealant and torque to 135–149 N.m (100–110 ft-lb).

- 6 Torque oppositely and evenly to 11.5–24.5 N.m (8.5–18 ft-lb).
- 7 Apply medium strength sealant and torque to 11.5–24.5 N.m (8.5–18 ft-lb).
- 8 Torque oppositely and evenly to 81–88 N.m (60–65 ft-lb).
- 9 When installing the relief valve seat (46), install seals (43) and o-rings (20) at the pump fluid inlet **and** on the opposite side of the inlet manifold (5).
- 10 **Do not** install relief valve seat (46) on this side of the inlet manifold (5).

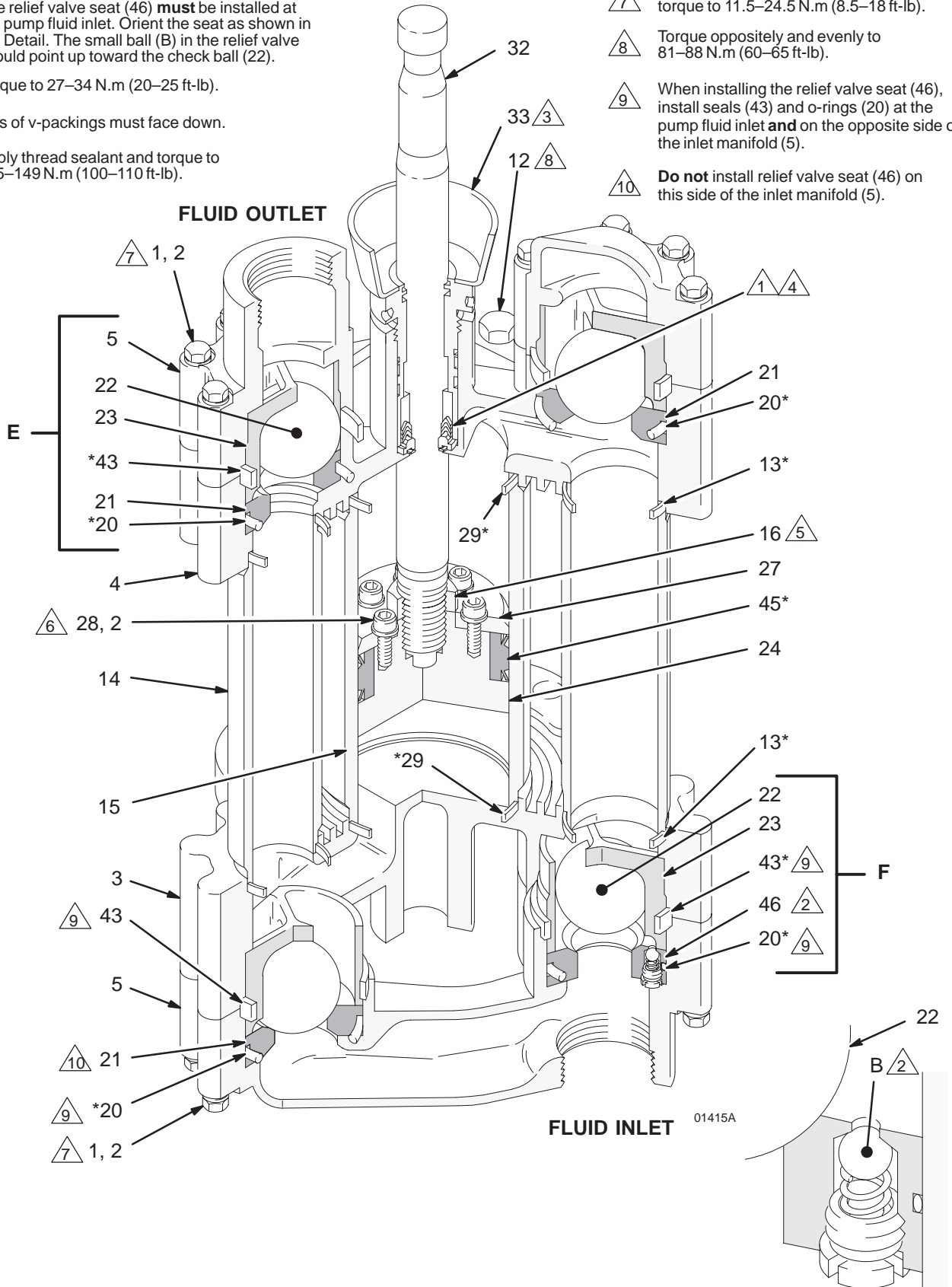

Detail of Inlet Valve Seat (46)

Fig. 17

04944A

Parts (Bulldog Pumps)

CARBON STEEL PUMPS

Model 218511, Series B, 3:1 Ratio

Model 218519, Series B, 2:1 Ratio

Model 218526, Series B, 1.5:1 Ratio

Ref No.	Part No.	Description	Qty
101	215255	MOTOR, Bulldog See manual 307304 for parts	1
102	218515	DISPLACEMENT PUMP For Model 218511; see page 34	1
	218523	DISPLACEMENT PUMP For Model 218519; see page 36	1
	218530	DISPLACEMENT PUMP For Model 218526; see page 38	1
103	180486	ROD, tie; 323 mm (12.7"); 5/8-11 unc-2a	3
104	101712	LOCKNUT	3
105	184129	COUPLER	2
106	186925	COUPLING NUT	1

Coupling Jaw Kit 222649

High-Flo Carbon Steel Displacement Pumps Series G and above, and Stainless Steel Displacement Pumps Series H and above use new style couplers (105), nut (106), and shaft (see item 32 on pages 34, 36, and 38). The nut and couplers used in earlier Series pumps do not fit the new shaft and are no longer available. To replace an old shaft, coupler or coupling nut, order the entire Coupling Jaw Kit 222649.

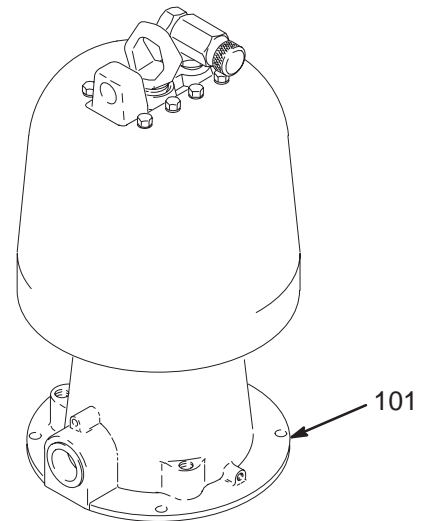

SEVERE-DUTY, ELECTROPOLISHED STAINLESS STEEL PUMPS

Model 218512, Series C, 3:1 Ratio

Model 218520, Series C, 2:1 Ratio

Model 218527, Series C, 1.5:1 Ratio

Ref No.	Part No.	Description	Qty
101	215255	MOTOR, Bulldog See manual 307304 for parts	1
102	218516	DISPLACEMENT PUMP For Model 218512; see page 34	1
	218524	DISPLACEMENT PUMP For Model 218520; see page 36	1
	218531	DISPLACEMENT PUMP For Model 218527; see page 38	1
103	180487	ROD, tie; 323 mm (12.7"); 5/8-11 unc-2a	3
104	102216	LOCKNUT	3
105	184129	COUPLER	2
106	186925	COUPLING NUT	1

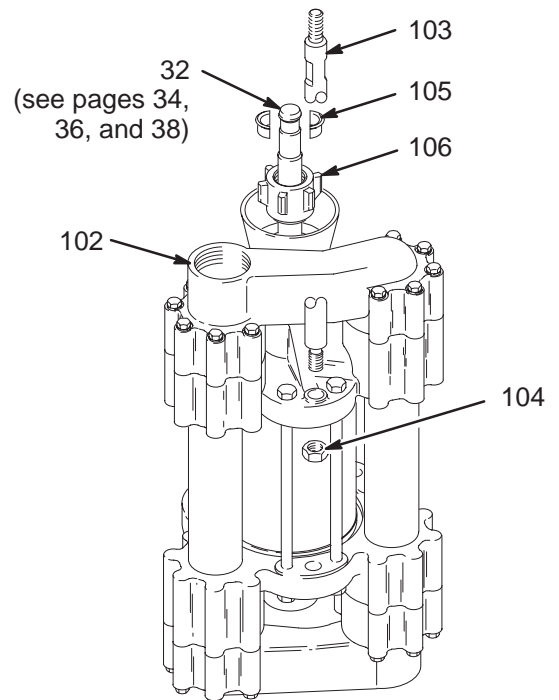

01419

Parts (King Pumps)

CARBON STEEL PUMPS

Model 218513, Series C, 6:1 Ratio

Model 218521, Series C, 4:1 Ratio

Model 218528, Series C, 3:1 Ratio

Ref No.	Part No.	Description	Qty
101	220106	MOTOR, King See manual 307741 for parts	1
102	218515	DISPLACEMENT PUMP For Model 218513; see page 34	1
	218523	DISPLACEMENT PUMP For Model 218521; see page 36	1
	218530	DISPLACEMENT PUMP For Model 218528; see page 38	1
103	180486	ROD, tie; 323 mm (12.7"); 5/8–11 unc–2a	3
104	101712	LOCKNUT	3
105	184129	COUPLER	2
106	186925	COUPLING NUT	1

SEVERE-DUTY, ELECTROPOLISHED STAINLESS STEEL PUMPS

Model 218514, Series D, 6:1 Ratio

Model 218522, Series D, 4:1 Ratio

Model 240601, Series A, 4:1 Ratio, with bsp threads and tri-clamp adapters

Model 240602, Series A, 4:1 Ratio, with bsp threads, without tri-clamp adapters

Model 218529, Series D, 3:1 Ratio

Model 240598, Series A, 3:1 Ratio, with bsp threads and tri-clamp adapters

Model 240599, Series A, 3:1 Ratio, with bsp threads, without tri-clamp adapters

Ref No.	Part No.	Description	Qty
101	220106	MOTOR, King (shown); used on Models 218514, 218522, & 218529 See manual 307741 for parts	1
	235525	MOTOR, King; used on Models 240598, 240599, 240601, & 240602 See manual 307741 for parts	1
102	218516	DISPLACEMENT PUMP For Model 218514; see page 34	1
	218524	DISPLACEMENT PUMP For Model 218522; see page 36	1
	240592	DISPLACEMENT PUMP, with tri-clamp adapters, for Model 240601; see page 40	1
	240593	DISPLACEMENT PUMP, without tri-clamp adapters, for Model 240602; see page 40	1
	218531	DISPLACEMENT PUMP For Model 218529; see page 38	1
	240589	DISPLACEMENT PUMP, with tri-clamp adapters, for Model 240598; see page 40	1
	240590	DISPLACEMENT PUMP, without tri-clamp adapters, for Model 240599; see page 40	1
103	180487	ROD, tie; 323 mm (12.7"); 5/8–11 unc–2a	3
104	102216	LOCKNUT	3
105	184129	COUPLER	2
106	186925	COUPLING NUT	1

Parts (King Pumps)

Coupling Jaw Kit 222649

High-Flo Carbon Steel Displacement Pumps Series G and above, and Stainless Steel Displacement Pumps Series H and above use new style couplers (105), nut (106), and shaft (see item 32 on pages 34, 36, 38, and 40). The nut and couplers used in earlier Series pumps do not fit the new shaft and are no longer available. To replace an old shaft, coupler or coupling nut, order the entire Coupling Jaw Kit 222649.

Model 218514 Shown

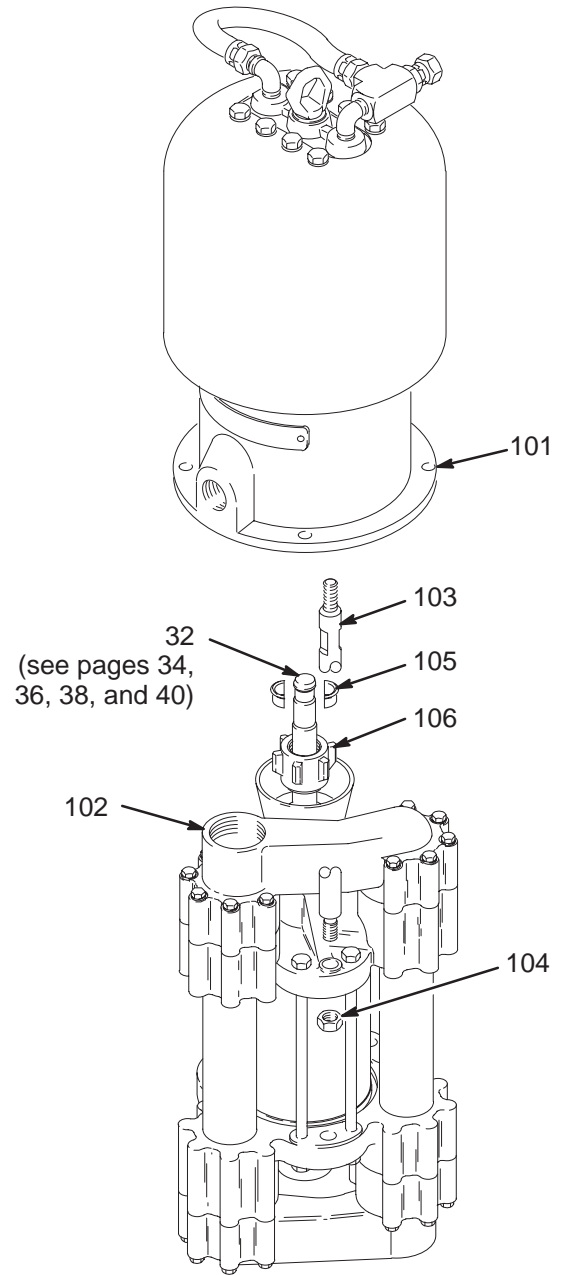

01420

Parts (Senator Pumps)

High-Flo pumps powered by a Senator Air Motor are not available as complete pumps. Order the parts listed below to build a Senator High-Flo pump.

Pump Ratio	Maximum Working Pressure	Carbon Steel Displacement Pump	Stainless Steel Displacement Pump
1.8:1	1.49 MPa 14.9 bar (216 psi)	218515 <i>See page 34</i>	218516 <i>See page 34</i>
1:1	0.83 MPa 8.3 bar (120 psi)	218523 <i>See page 36</i>	218524 <i>See page 36</i>
0.7:1	0.58 MPa 5.8 bar (84 psi)	218530 <i>See page 38</i>	218531 <i>See page 38</i>

CARBON STEEL PUMPS

Ref No.	Part No.	Description	Qty
101	217540	SENATOR AIR MOTOR See manual 307592 for parts	1
102	—	DISPLACEMENT PUMP Order carbon steel displacement pump from chart at right	1
103	180486	ROD, tie; 323 mm (12.7"); 5/8-11 unc-2a	3
104	101712	LOCKNUT	3
105	184129	COUPLER	2
106	186925	COUPLING NUT	1

SEVERE-DUTY, ELECTROPOLISHED STAINLESS STEEL PUMPS

Ref No.	Part No.	Description	Qty
101	217540	SENATOR AIR MOTOR See manual 307592 for parts	1
102	—	DISPLACEMENT PUMP Order stainless steel displacement pump from chart at right	1
103	180487	ROD, tie; 323 mm (12.7"); 5/8-11 unc-2a	3
104	102216	LOCKNUT	3
105	184129	COUPLER	2
106	186925	COUPLING NUT	1

Coupling Jaw Kit 222649

High-Flo Carbon Steel Displacement Pumps Series G and above, and Stainless Steel Displacement Pumps Series H and above use new style couplers (105), nut (106), and shaft (see item 32 on pages 34, 36, and 38). The nut and couplers used in earlier Series pumps do not fit the new shaft and are no longer available. To replace an old shaft, coupler or coupling nut, order the entire Coupling Jaw Kit 222649.

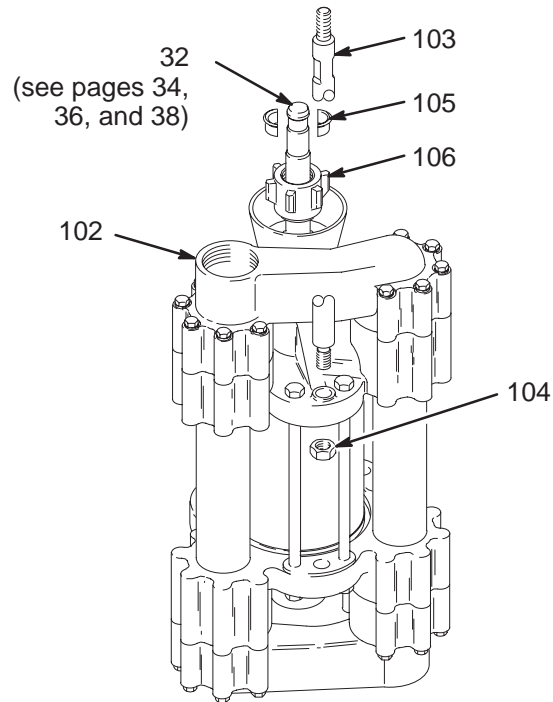
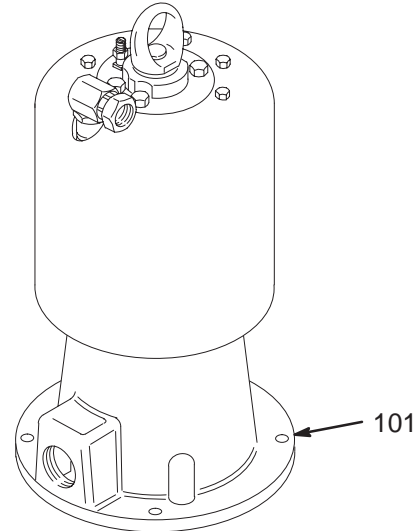

01422

Parts (Viscount II Pumps)

CARBON STEEL PUMPS

Model 218533, Series D, Viscount II 600 Pump

Model 218535, Series D, Viscount II 400 Pump

Model 218537, Series D, Viscount II 300 Pump

Ref No.	Part No.	Description	Qty
101	223646	MOTOR, Viscount II Quiet See manual 308048 for parts	1
102	218515	DISPLACEMENT PUMP For Model 218533; see page 34	1
	218523	DISPLACEMENT PUMP For Model 218535; see page 36	1
	218530	DISPLACEMENT PUMP For Model 218537; see page 38	1
103	180486	ROD, tie; 323 mm (12.7"); 5/8-11 unc-2a	3
104	101712	LOCKNUT	3
105	184129	COUPLER	2
106	186925	COUPLING NUT	1

Coupling Jaw Kit 222649

High-Flo Carbon Steel Displacement Pumps Series G and above, and Stainless Steel Displacement Pumps Series H and above use new style couplers (105), nut (106), and shaft (see item 32 on pages 34, 36, and 38). The nut and couplers used in earlier Series pumps do not fit the new shaft and are no longer available. To replace an old shaft, coupler or coupling nut, order the entire Coupling Jaw Kit 222649.

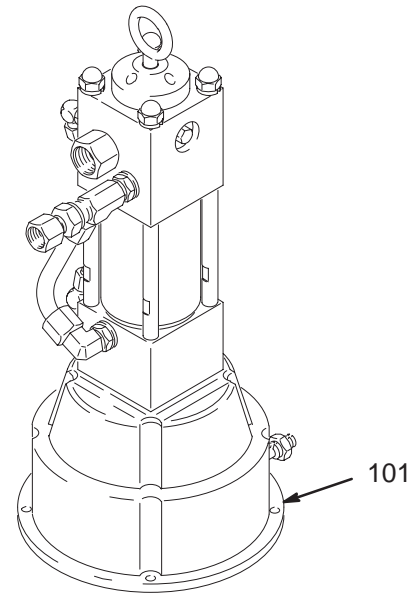

SEVERE-DUTY, ELECTROPOLISHED STAINLESS STEEL PUMPS

Model 218534, Series E, Viscount II 600 Pump

Model 218536, Series E, Viscount II 400 Pump

Model 218538, Series E, Viscount II 300 Pump

Ref No.	Part No.	Description	Qty
101	223646	MOTOR, Viscount II Quiet See manual 308048 for parts	1
102	218516	DISPLACEMENT PUMP For Model 218534; see page 34	1
	218524	DISPLACEMENT PUMP For Model 218536; see page 36	1
	218531	DISPLACEMENT PUMP For Model 218538; see page 38	1
103	180487	ROD, tie; 323 mm (12.7"); 5/8-11 unc-2a	3
104	102216	LOCKNUT	3
105	184129	COUPLER	2
106	186925	COUPLING NUT	1

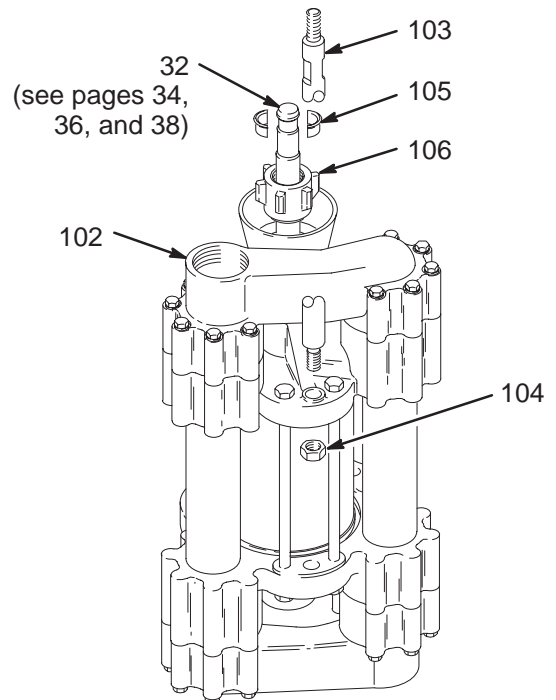

01421

Parts

Model 218515, Series J

Carbon Steel Displacement Pump



For 3:1 Bulldog, 6:1 King, and Viscount 600 Pumps

Model 218516, Series L

Stainless Steel Displacement Pump

For 3:1 Bulldog, 6:1 King, and Viscount 600 Pumps

Stainless Steel Model Shown

-  Used on stainless steel model only.
-  Stainless steel wet-cup shown.
-  Seat with relief valve (46) must be installed at pump fluid inlet. Kit includes items 20 and 43.

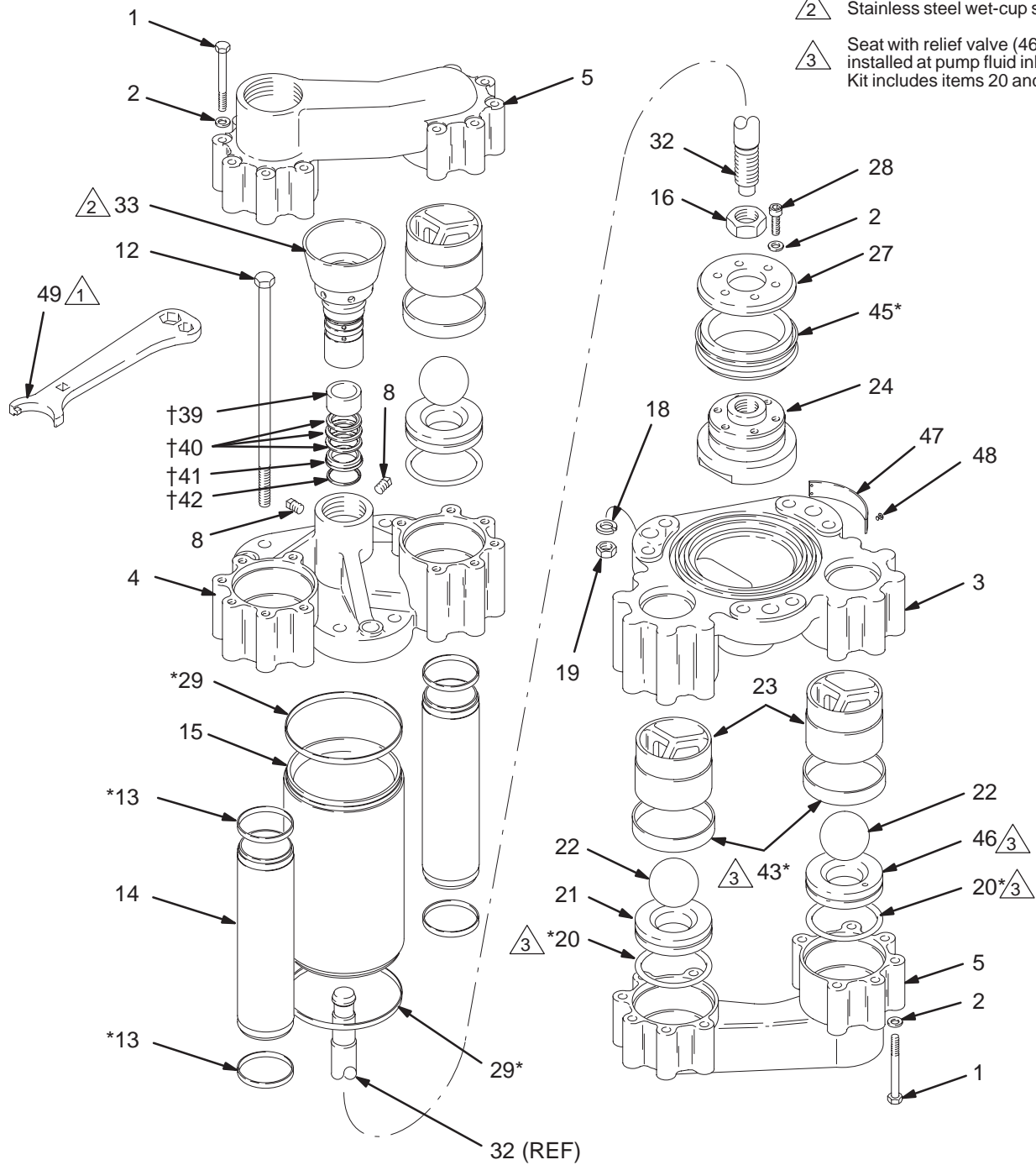

01423A

Parts

Model 218515, Series J

Carbon Steel Displacement Pump
For 3:1 Bulldog, 6:1 King, and Viscount 600 Pumps

Ref. No.	Part No.	Description	Qty.
1	107557	CAPSCREW, hex head; M8 x 1.25; 75 mm lg	24
2	111003	WASHER, flat; Sz. 8	30
3	180521	HOUSING, valve, intake	1
4	180522	HOUSING, valve, outlet	1
5	180520	MANIFOLD	2
8	100403	PLUG, pipe; 1/8–27 npt	2
12	107556	CAPSCREW, hex head; M12 x 1.75; 280 mm lg	6
13*	180760	SEAL; UHMWPE	4
14	180531	TUBE, riser	2
15	180499	CYLINDER, pump	1
16	107552	NUT, jam, hex; M24 x 2 mm	1
18	107541	LOCKWASHER, spring, Sz. 12	6
19	107539	NUT, hex; M 12 x 1.75 mm	6
20*	107545	O-RING; PTFE	4
21	180529	SEAT, valve; SST	3
22	102974	BALL	4
23	180509	GUIDE, ball	4
24	188529	PISTON, pump	1
27	188532	PLATE, retaining	1
28	108122	CAPSCREW, hex socket; M8 x 1.25; 25 mm lg	6
29*	180759	SEAL; UHMWPE	2
32	185197	SHAFT, piston (included in 222649 Coupling Jaw Kit; see pages 29–32)	1
33	180511	WET-CUP/PACKING NUT	1
39†	180640	GLAND, packing, female	1
40†	180641	V-PACKING; UHMWPE	3
41†	180639	GLAND, packing, male	1
42†	181228	GLAND, seal; UHMWPE	1
43*	180761	SEAL; UHMWPE	4
45*	183744	SEAL, piston; UHMWPE	1
46	237744	SEAT, valve, relief (also includes two of item 20 and two of item 43)	1
47	183460	LABEL, warning	1
48	100055	SCREW, drive	2

* These parts are included in Pump Seal Repair Kit 218735, which may be purchased separately. See page 45.

† These parts are included in the Throat Packing Kit, which may be purchased separately. Material varies according to kit. See page 45.

Model 218516, Series L

Stainless Steel Displacement Pump
For 3:1 Bulldog, 6:1 King, and Viscount 600 Pumps

Ref. No.	Part No.	Description	Qty.
1	107554	CAPSCREW, hex head; M8 x 1.25; 75 mm lg; SST	24
2	111003	WASHER, flat; Sz. 8	30
3	180523	HOUSING, valve, intake; SST	1
4	180524	HOUSING, valve, outlet; SST	1
5	180519	MANIFOLD; SST	2
8	107570	PLUG, pipe sq hd; 1/8–27 npt; SST	2
12	107553	CAPSCREW, hex head; M12 x 1.75; 280 mm lg; SST	6
13*	180760	SEAL; UHMWPE	4
14	180530	TUBE, riser; SST	2
15	180499	CYLINDER, pump; SST	1
16	107552	NUT, jam, hex; M24 x 2 mm	1
18	108792	LOCKWASHER, spring, Sz. 12	6
19	107538	NUT, hex; M 12 x 1.75 mm; SST	6
20*	107545	O-RING; PTFE	4
21	180529	SEAT, valve; SST	3
22	110294	BALL	4
23	180509	GUIDE, ball	4
24	188526	PISTON, pump	1
27	188535	PLATE, retaining	1
28	108121	CAPSCREW, hex socket; M8 x 1.25; 25 mm lg; SST	6
29*	180759	SEAL; UHMWPE	2
32	185197	SHAFT, piston (included in 222649 Coupling Jaw Kit; see pages 29–32)	1
33	237650	WET-CUP/PACKING NUT; SST	1
39†	180640	GLAND, packing, female	1
40†	180641	V-PACKING; UHMWPE	3
41†	180639	GLAND, packing, male	1
42†	181228	GLAND, seal; UHMWPE	1
43*	180761	SEAL; UHMWPE	4
45*	183744	SEAL, piston; UHMWPE	1
46	237744	SEAT, valve, relief (also includes two of item 20 and two of item 43)	1
47	183460	LABEL, warning	1
48	103972	SCREW, drive	2
49	112887	WRENCH, packing nut	1

* These parts are included in Pump Seal Repair Kit 218735, which may be purchased separately. See page 45.

† These parts are included in the Throat Packing Kit, which may be purchased separately. Material varies according to kit. See page 45.

Parts

Model 218523, Series J

Carbon Steel Displacement Pump



For 2:1 Bulldog, 4:1 King, and Viscount 400 Pumps

Model 218524, Series L

Stainless Steel Displacement Pump

For 2:1 Bulldog, 4:1 King, and Viscount 400 Pumps

Stainless Steel Model Shown

-  Used on stainless steel model only.
-  Stainless steel wet-cup shown.
-  Seat with relief valve (46) must be installed at pump fluid inlet. Kit includes items 20 and 43.

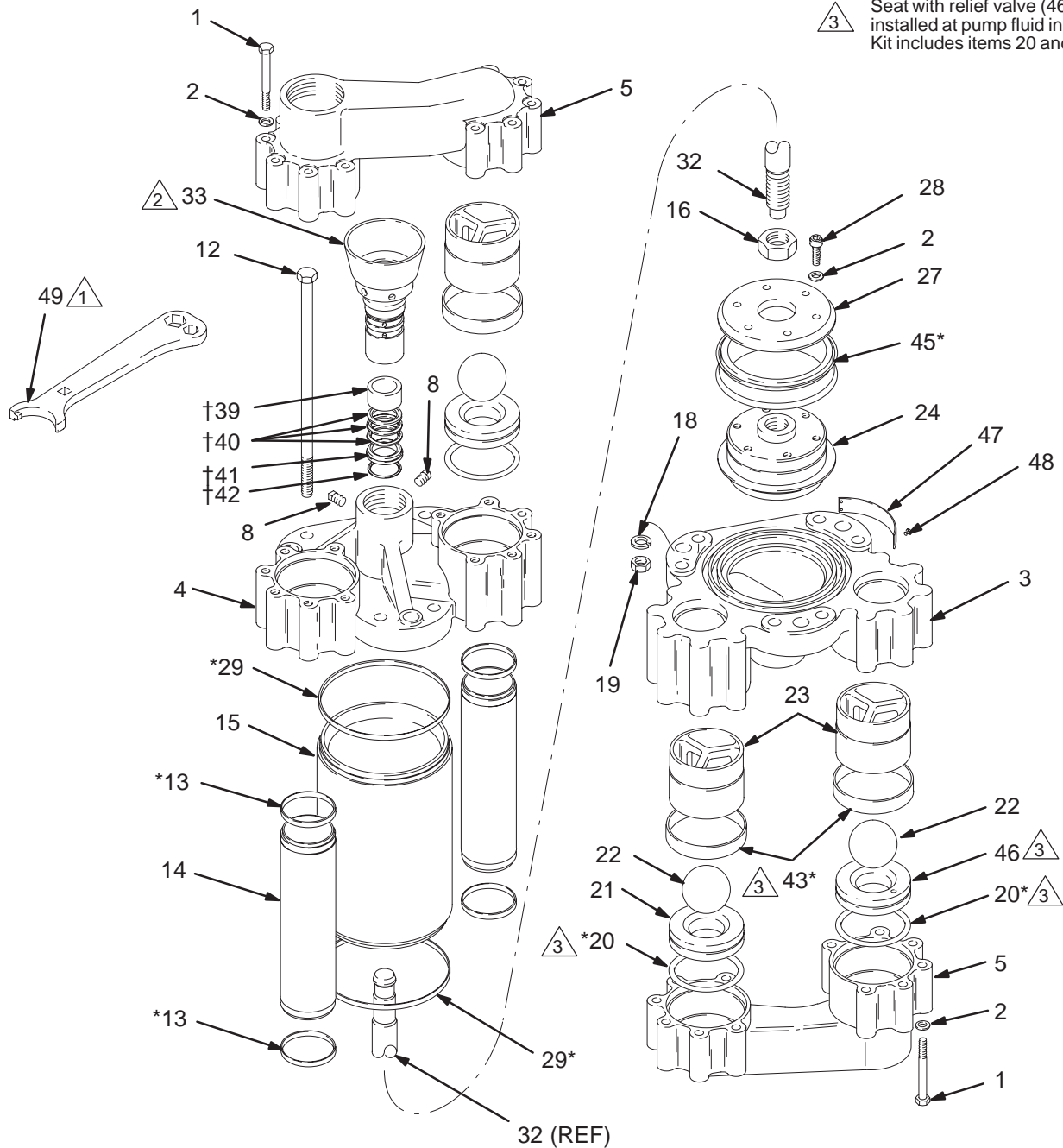

Parts

Model 218523, Series J

Carbon Steel Displacement Pump
For 2:1 Bulldog, 4:1 King, and Viscount 400 Pumps

Ref. No.	Part No.	Description	Qty.
1	107557	CAPSCREW, hex head; M8 x 1.25; 75 mm lg	24
2	111003	WASHER, flat; Sz. 8	30
3	180521	HOUSING, valve, intake	1
4	180522	HOUSING, valve, outlet	1
5	180520	MANIFOLD	2
8	100403	PLUG, pipe; 1/8–27 npt	2
12	107556	CAPSCREW, hex head; M12 x 1.75; 280 mm lg	6
13*	180760	SEAL; UHMWPE	4
14	180531	TUBE, riser	2
15	180498	CYLINDER, pump	1
16	107552	NUT, jam, hex; M24 x 2 mm	1
18	107541	LOCKWASHER, spring, Sz. 12	6
19	107539	NUT, hex; M 12 x 1.75 mm	6
20*	107545	O-RING; PTFE	4
21	180529	SEAT, valve; SST	3
22	102974	BALL	4
23	180509	GUIDE, ball	4
24	188528	PISTON, pump	1
27	188531	PLATE, retaining	1
28	108122	CAPSCREW, hex socket; M8 x 1.25; 25 mm lg	6
29*	180758	SEAL; UHMWPE	2
32	185197	SHAFT, piston (included in 222649 Coupling Jaw Kit; see pages 29–32)	1
33	180511	WET-CUP/PACKING NUT	1
39†	180640	GLAND, packing, female	1
40†	180641	V-PACKING; UHMWPE	3
41†	180639	GLAND, packing, male	1
42†	181228	GLAND, seal; UHMWPE	1
43*	180761	SEAL; UHMWPE	4
45*	183743	SEAL, piston; UHMWPE	1
46	237744	SEAT, valve, relief (also includes two of item 20 and two of item 43)	1
47	183460	LABEL, warning	1
48	100055	SCREW, drive	2

* These parts are included in Pump Seal Repair Kit 218737, which may be purchased separately. See page 45.

† These parts are included in the Throat Packing Kit, which may be purchased separately. Material varies according to kit. See page 45.

Model 218524, Series L

Stainless Steel Displacement Pump
For 2:1 Bulldog, 4:1 King, and Viscount 400 Pumps

Ref. No.	Part No.	Description	Qty.
1	107554	CAPSCREW, hex head; M8 x 1.25; 75 mm lg; SST	24
2	111003	WASHER, flat; Sz. 8	30
3	180523	HOUSING, valve, intake; SST	1
4	180524	HOUSING, valve, outlet; SST	1
5	180519	MANIFOLD; SST	2
8	107570	PLUG, pipe sq hd; 1/8–27 npt; SST	2
12	107553	CAPSCREW, hex head; M12 x 1.75; 280 mm lg; SST	6
13*	180760	SEAL; UHMWPE	4
14	180530	TUBE, riser; SST	2
15	180498	CYLINDER, pump; SST	1
16	107552	NUT, jam, hex; M24 x 2 mm	1
18	108792	LOCKWASHER, spring, Sz. 12	6
19	107538	NUT, hex; M 12 x 1.75 mm; SST	6
20*	107545	O-RING; PTFE	4
21	180529	SEAT, valve; SST	3
22	110294	BALL	4
23	180509	GUIDE, ball	4
24	188525	PISTON, pump	1
27	188534	PLATE, retaining	1
28	108121	CAPSCREW, hex socket; M8 x 1.25; 25 mm lg; SST	6
29*	180758	SEAL; UHMWPE	2
32	185197	SHAFT, piston (included in 222649 Coupling Jaw Kit; see pages 29–32)	1
33	237650	WET-CUP/PACKING NUT; SST	1
39†	180640	GLAND, packing, female	1
40†	180641	V-PACKING; UHMWPE	3
41†	180639	GLAND, packing, male	1
42†	181228	GLAND, seal; UHMWPE	1
43*	180761	SEAL; UHMWPE	4
45*	183743	SEAL, piston; UHMWPE	1
46	237744	SEAT, valve, relief (also includes two of item 20 and two of item 43)	1
47	183460	LABEL, warning	1
48	103972	SCREW, drive	2
49	112887	WRENCH, packing nut	1

* These parts are included in Pump Seal Repair Kit 218737, which may be purchased separately. See page 45.

† These parts are included in the Throat Packing Kit, which may be purchased separately. Material varies according to kit. See page 45.

Parts

Model 218530, Series J

Carbon Steel Displacement Pump



For 1.5:1 Bulldog, 3:1 King, and Viscount 300 Pumps

Model 218531, Series L

Stainless Steel Displacement Pump

For 1.5:1 Bulldog, 3:1 King, and Viscount 300 Pumps

Stainless Steel Model Shown

-  Used on stainless steel model only.
-  Stainless steel wet-cup shown.
-  Seat with relief valve (46) must be installed at pump fluid inlet. Kit includes items 20 and 43.

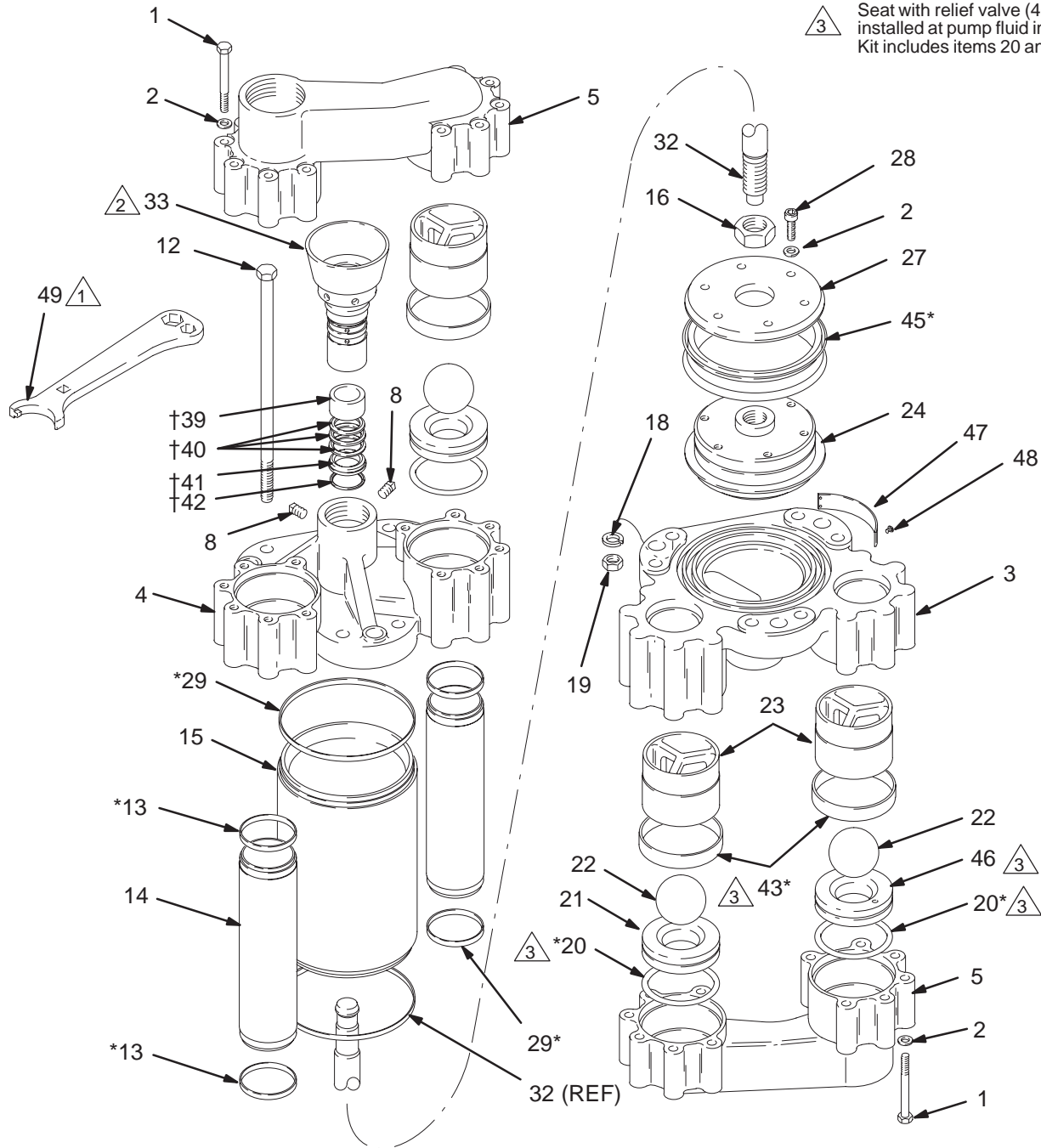

Parts

Model 218530, Series J

Carbon Steel Displacement Pump

For 1.5:1 Bulldog, 3:1 King, and Viscount 300 Pumps

Ref. No.	Part No.	Description	Qty.
1	107557	CAPSCREW, hex head; M8 x 1.25; 75 mm lg	24
2	111003	WASHER, flat; Sz. 8	30
3	180521	HOUSING, valve, intake	1
4	180522	HOUSING, valve, outlet	1
5	180520	MANIFOLD	2
8	100403	PLUG, pipe; 1/8–27 npt	2
12	107556	CAPSCREW, hex head; M12 x 1.75; 280 mm lg	6
13*	180760	SEAL; UHMWPE	4
14	180531	TUBE, riser	2
15	180497	CYLINDER, pump	1
16	107552	NUT, jam, hex; M24 x 2 mm	1
18	107541	LOCKWASHER, spring, Sz. 12	6
19	107539	NUT, hex; M 12 x 1.75 mm	6
20*	107545	O-RING; PTFE	4
21	180529	SEAT, valve; SST	3
22	102974	BALL	4
23	180509	GUIDE, ball	4
24	188527	PISTON, pump	1
27	188530	PLATE, retaining	1
28	108122	CAPSCREW, hex socket; M8 x 1.25; 25 mm lg	6
29*	180757	SEAL; UHMWPE	2
32	185197	SHAFT, piston (included in 222649 Coupling Jaw Kit; see pages 29–32)	1
33	180511	WET-CUP/PACKING NUT	1
39†	180640	GLAND, packing, female	1
40†	180641	V-PACKING; UHMWPE	3
41†	180639	GLAND, packing, male	1
42†	181228	GLAND, seal; UHMWPE	1
43*	180761	SEAL; UHMWPE	4
45*	183742	SEAL, piston; UHMWPE	1
46	237744	SEAT, valve, relief (also includes two of item 20 and two of item 43)	1
47	183460	LABEL, warning	1
48	100055	SCREW, drive	2

* These parts are included in Pump Seal Repair Kit 218739, which may be purchased separately. See page 45.

† These parts are included in the Throat Packing Kit, which may be purchased separately. Material varies according to kit. See page 45.

Model 218531, Series L

Stainless Steel Displacement Pump

For 1.5:1 Bulldog, 3:1 King, and Viscount 300 Pumps

Ref. No.	Part No.	Description	Qty.
1	107554	CAPSCREW, hex head; M8 x 1.25; 75 mm lg; SST	24
2	111003	WASHER, flat; Sz. 8	30
3	180523	HOUSING, valve, intake; SST	1
4	180524	HOUSING, valve, outlet; SST	1
5	180519	MANIFOLD; SST	2
8	107570	PLUG, pipe sq hd; 1/8–27 npt; SST	2
12	107553	CAPSCREW, hex head; M12 x 1.75; 280 mm lg; SST	6
13*	180760	SEAL; UHMWPE	4
14	180530	TUBE, riser; SST	2
15	180497	CYLINDER, pump; SST	1
16	107552	NUT, jam, hex; M24 x 2 mm	1
18	108792	LOCKWASHER, spring, Sz. 12	6
19	107538	NUT, hex; M 12 x 1.75 mm; SST	6
20*	107545	O-RING; PTFE	4
21	180529	SEAT, valve; SST	3
22	110294	BALL	4
23	180509	GUIDE, ball	4
24	188524	PISTON, pump	1
27	188533	PLATE, retaining	1
28	108121	CAPSCREW, hex socket; M8 x 1.25; 25 mm lg; SST	6
29*	180757	SEAL; UHMWPE	2
32	185197	SHAFT, piston (included in 222649 Coupling Jaw Kit; see pages 29–32)	1
33	237650	WET-CUP/PACKING NUT; SST	1
39†	180640	GLAND, packing, female	1
40†	180641	V-PACKING; UHMWPE	3
41†	180639	GLAND, packing, male	1
42†	181228	GLAND, seal; UHMWPE	1
43*	180761	SEAL; UHMWPE	4
45*	183742	SEAL, piston; UHMWPE	1
46	237744	SEAT, valve, relief (also includes two of item 20 and two of item 43)	1
47	183460	LABEL, warning	1
48	103972	SCREW, drive	2
49	112887	WRENCH, packing nut	1

* These parts are included in Pump Seal Repair Kit 218739, which may be purchased separately. See page 45.

† These parts are included in the Throat Packing Kit, which may be purchased separately. Material varies according to kit. See page 45.

Parts

Model 240589, Series A

Stainless Steel Displacement Pump with bsp threads and tri-clamp adapters; for 3:1 King Pumps

Model 240590, Series A

Stainless Steel Displacement Pump with bsp threads, without tri-clamp adapters; for 3:1 King Pumps

Model 240592, Series A

Stainless Steel Displacement Pump with bsp threads and tri-clamp adapters; for 4:1 King Pumps

Model 240593, Series A

Stainless Steel Displacement Pump with bsp threads, without tri-clamp adapters; for 4:1 King Pumps

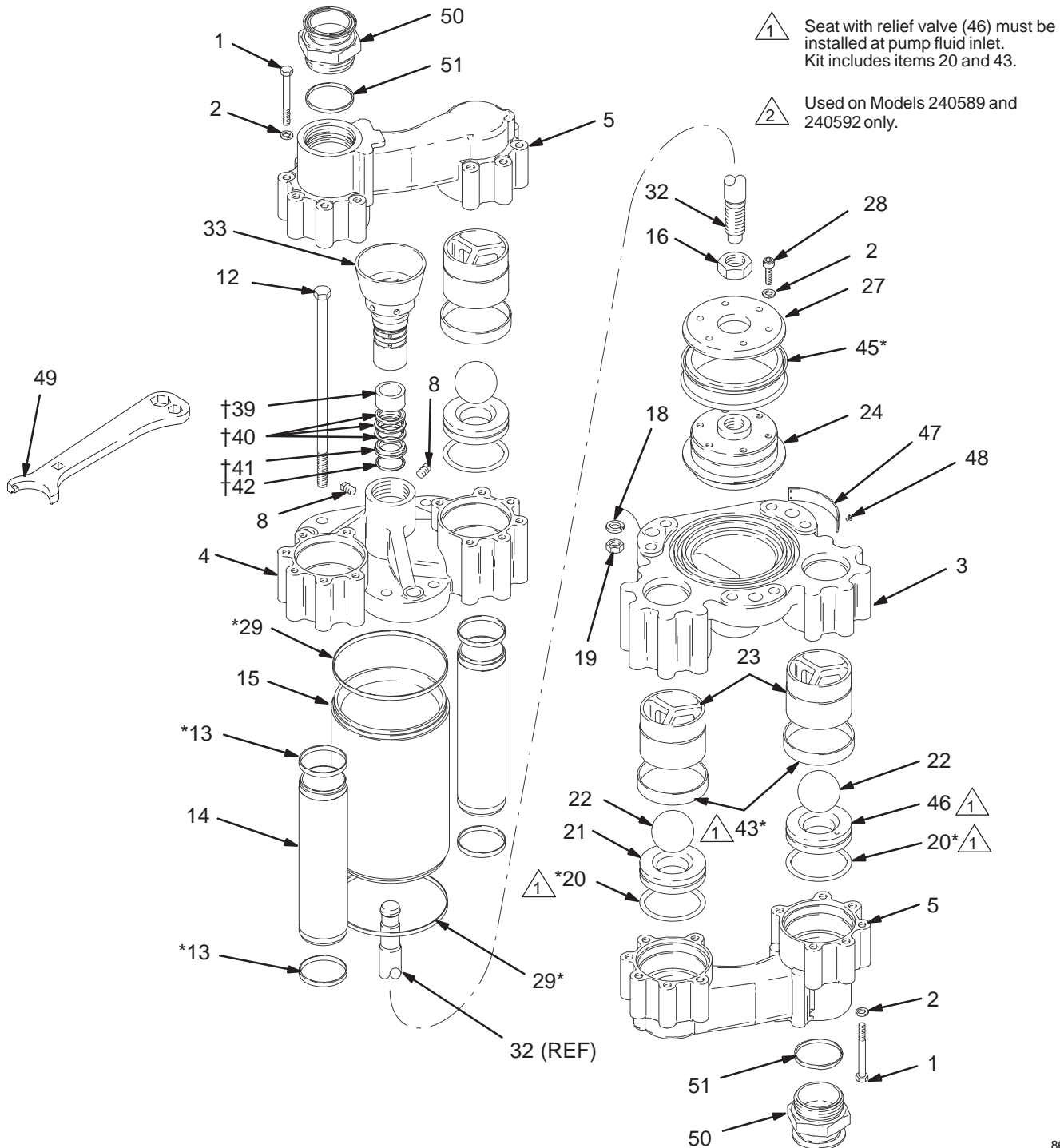

Parts

Model 240589, Series A

Stainless Steel Displacement Pump with bsp threads and tri-clamp adapters; for 3:1 King Pumps

Model 240590, Series A

Stainless Steel Displacement Pump with bsp threads, without tri-clamp adapters; for 3:1 King Pumps

Ref. No.	Part No.	Description	Qty.
1	107554	CAPSCREW, hex head; M8 x 1.25; 75 mm lg; SST	24
2	111003	WASHER, flat; Sz. 8	30
3	180523	HOUSING, valve, intake; SST	1
4	180524	HOUSING, valve, outlet; SST	1
5	193203	MANIFOLD; SST	2
8	107570	PLUG, pipe sq hd; 1/8–27 npt; SST	2
12	107553	CAPSCREW, hex head; M12 x 1.75; 280 mm lg; SST	6
13*	180760	SEAL; UHMWPE	4
14	180530	TUBE, riser; SST	2
15	180497	CYLINDER, pump; SST	1
16	107552	NUT, jam, hex; M24 x 2 mm	1
18	108792	LOCKWASHER, spring, Sz. 12	6
19	107538	NUT, hex; M 12 x 1.75 mm; SST	6
20*	107545	O-RING; PTFE	4
21	180529	SEAT, valve; SST	3
22	110294	BALL	4
23	180509	GUIDE, ball	4
24	188524	PISTON, pump	1
27	188533	PLATE, retaining	1
28	108121	CAPSCREW, hex socket; M8 x 1.25; 25 mm lg; SST	6
29*	180757	SEAL; UHMWPE	2
32	185197	SHAFT, piston (included in 222649 Coupling Jaw Kit; see pages 29–32)	1
33	237650	WET-CUP/PACKING NUT; SST	1
39†	180640	GLAND, packing, female	1
40†	180641	V-PACKING; UHMWPE	3
41†	180639	GLAND, packing, male	1
42†	181228	GLAND, seal; UHMWPE	1
43*	180761	SEAL; UHMWPE	4
45*	183742	SEAL, piston; UHMWPE	1
46	237744	SEAT, valve, relief (also includes two of item 20 and two of item 43)	1
47	183460	LABEL, warning	1
48	103972	SCREW, drive	2
49	112887	WRENCH, packing nut	1
50	193202	ADAPTER, tri-clamp; Model 240589 only	2
51	193424	SEAL; 2 in. (50 mm) ID; PTFE; Model 240589 only	1

* These parts are included in Pump Seal Repair Kit 218739, which may be purchased separately. See page 45.

† These parts are included in the Throat Packing Kit, which may be purchased separately. Material varies according to kit. See page 45.

Model 240592, Series A

Stainless Steel Displacement Pump with bsp threads and tri-clamp adapters; for 4:1 King Pumps

Model 240593, Series A

Stainless Steel Displacement Pump with bsp threads, without tri-clamp adapters; for 4:1 King Pumps

Ref. No.	Part No.	Description	Qty.
1	107554	CAPSCREW, hex head; M8 x 1.25; 75 mm lg; SST	24
2	111003	WASHER, flat; Sz. 8	30
3	180523	HOUSING, valve, intake; SST	1
4	180524	HOUSING, valve, outlet; SST	1
5	193203	MANIFOLD; SST	2
8	107570	PLUG, pipe sq hd; 1/8–27 npt; SST	2
12	107553	CAPSCREW, hex head; M12 x 1.75; 280 mm lg; SST	6
13*	180760	SEAL; UHMWPE	4
14	180530	TUBE, riser; SST	2
15	180498	CYLINDER, pump; SST	1
16	107552	NUT, jam, hex; M24 x 2 mm	1
18	108792	LOCKWASHER, spring, Sz. 12	6
19	107538	NUT, hex; M 12 x 1.75 mm; SST	6
20*	107545	O-RING; PTFE	4
21	180529	SEAT, valve; SST	3
22	110294	BALL	4
23	180509	GUIDE, ball	4
24	188525	PISTON, pump	1
27	188534	PLATE, retaining	1
28	108121	CAPSCREW, hex socket; M8 x 1.25; 25 mm lg; SST	6
29*	180758	SEAL; UHMWPE	2
32	185197	SHAFT, piston (included in 222649 Coupling Jaw Kit; see pages 29–32)	1
33	237650	WET-CUP/PACKING NUT; SST	1
39†	180640	GLAND, packing, female	1
40†	180641	V-PACKING; UHMWPE	3
41†	180639	GLAND, packing, male	1
42†	181228	GLAND, seal; UHMWPE	1
43*	180761	SEAL; UHMWPE	4
45*	183743	SEAL, piston; UHMWPE	1
46	237744	SEAT, valve, relief (also includes two of item 20 and two of item 43)	1
47	183460	LABEL, warning	1
48	103972	SCREW, drive	2
49	112887	WRENCH, packing nut	1
50	193202	ADAPTER, tri-clamp; Model 240592 only	2
51	193424	SEAL; 2 in. (50 mm) ID; PTFE; Model 240592 only	1

* These parts are included in Pump Seal Repair Kit 218737, which may be purchased separately. See page 45.

† These parts are included in the Throat Packing Kit, which may be purchased separately. Material varies according to kit. See page 45.

Parts

Model 240595, Series A

Optional Stainless Steel Displacement Pump with bsp threads and tri-clamp adapters

Model 240596, Series A

Optional Stainless Steel Displacement Pump with bsp threads, without tri-clamp adapters

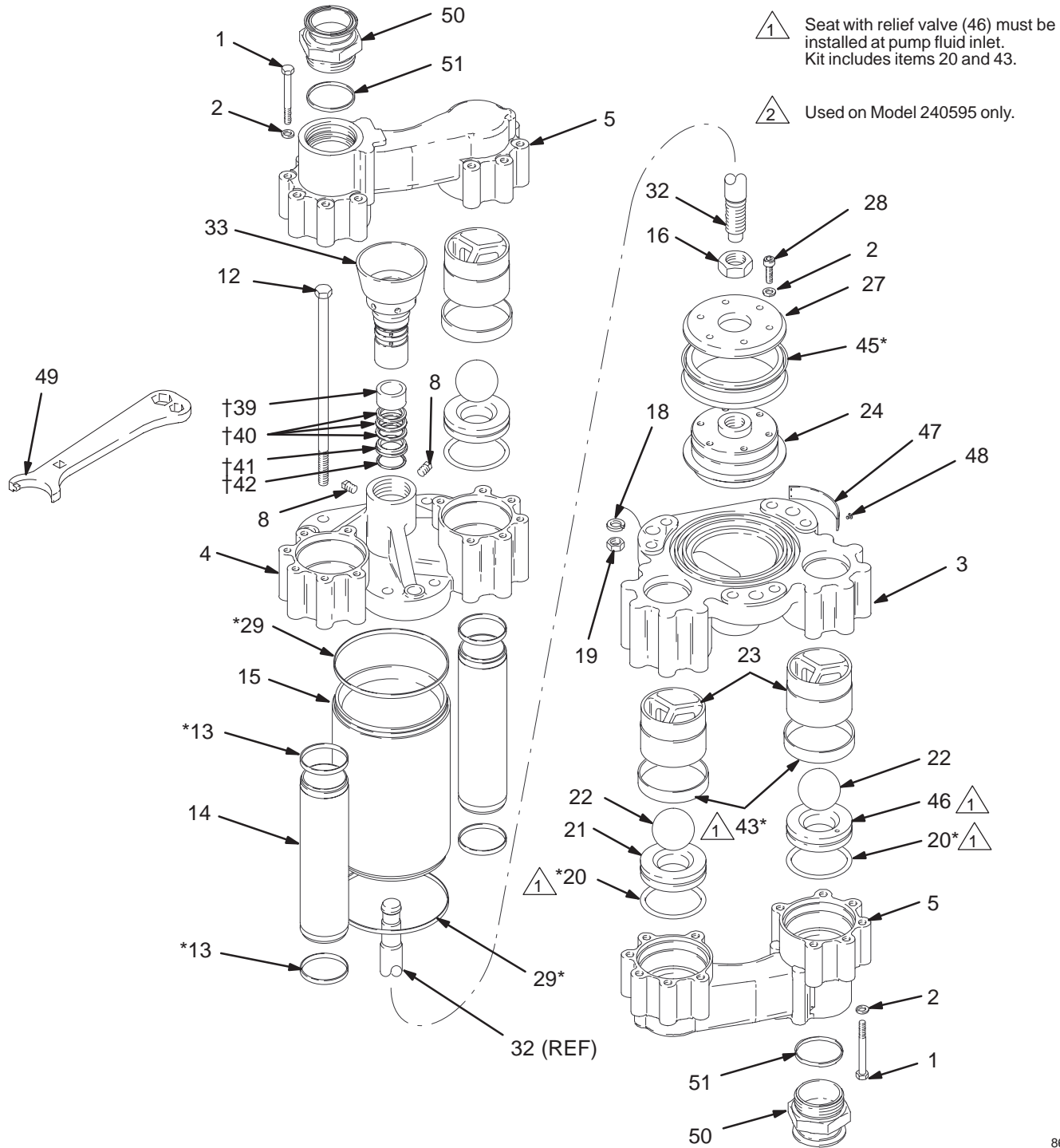

8687A

Parts

Model 240595, Series A

Optional Stainless Steel Displacement Pump with bsp threads and tri-clamp adapters

Model 240596, Series A

Optional Stainless Steel Displacement Pump with bsp threads, without tri-clamp adapters

Ref. No.	Part No.	Description	Qty.	Ref. No.	Part No.	Description	Qty.
1	107554	CAPSCREW, hex head; M8 x 1.25; 75 mm lg; SST	24	33	237650	WET-CUP/PACKING NUT; SST	1
2	111003	WASHER, flat; Sz. 8	30	39†	180640	GLAND, packing, female	1
3	180523	HOUSING, valve, intake; SST	1	40†	180641	V-PACKING; UHMWPE	3
4	180524	HOUSING, valve, outlet; SST	1	41†	180639	GLAND, packing, male	1
5	193203	MANIFOLD; SST	2	42†	181228	GLAND, seal; UHMWPE	1
8	107570	PLUG, pipe sq hd; 1/8–27 npt; SST	2	43*	180761	SEAL; UHMWPE	4
12	107553	CAPSCREW, hex head; M12 x 1.75; 280 mm lg; SST	6	45*	183744	SEAL, piston; UHMWPE	1
13*	180760	SEAL; UHMWPE	4	46	237744	SEAT, valve, relief (also includes two of item 20 and two of item 43)	1
14	180530	TUBE, riser; SST	2	47	183460	LABEL, warning	1
15	180499	CYLINDER, pump; SST	1	48	103972	SCREW, drive	2
16	107552	NUT, jam, hex; M24 x 2 mm	1	49	112887	WRENCH, packing nut	1
18	108792	LOCKWASHER, spring, Sz. 12	6	50	193202	ADAPTER, tri-clamp	2
19	107538	NUT, hex; M 12 x 1.75 mm; SST	6	51	193424	SEAL; 2 in. (50 mm) ID; PTFE	1
20*	107545	O-RING; PTFE	4	* These parts are included in Pump Seal Repair Kit 218735, which may be purchased separately. See page 45.			
21	180529	SEAT, valve; SST	3				
22	110294	BALL	4				
23	180509	GUIDE, ball	4				
24	188526	PISTON, pump	1	† These parts are included in the Throat Packing Kit, which may be purchased separately. Material varies according to kit. See page 45.			
27	188535	PLATE, retaining	1				
28	108121	CAPSCREW, hex socket; M8 x 1.25; 25 mm lg; SST	6				
29*	180759	SEAL; UHMWPE	2				
32	185197	SHAFT, piston (included in 222649 Coupling Jaw Kit; see pages 29–32)	1				

Manual Change Summary

Assembly Changed	Part Status	Ref. No.	Part No.	Name
240598, 240599, 240601, 240602	Old	101	220106	King Air Motor
	New	101	235525	King Air Motor

Repair and Conversion Kits

Use Only Genuine Graco Parts and Accessories

Pump Seal Repair Kit 218735

For Displacement Pumps 218515, 218516, 240595, and 240596.

Ref. No.	Part No.	Description	Qty.
13	180760	SEAL; UHMWPE	4
20	107545	O-RING; PTFE	4
29	180759	SEAL; UHMWPE	2
43	180761	SEAL; UHMWPE	4
45	183744	SEAL, piston; UHMWPE	1

Pump Seal Repair Kit 218737

For Displacement Pumps 218523, 218524, 240592, and 240593.

Ref. No.	Part No.	Description	Qty.
13	180760	SEAL; UHMWPE	4
20	107545	O-RING; PTFE	4
29	180758	SEAL; UHMWPE	2
43	180761	SEAL; UHMWPE	4
45	183743	SEAL, piston; UHMWPE	1

Pump Seal Repair Kit 218739

For Displacement Pumps 218530, 218531, 240589, and 240590.

Ref. No.	Part No.	Description	Qty.
13	180760	SEAL; UHMWPE	4
20	107545	O-RING; PTFE	4
29	180757	SEAL; UHMWPE	2
43	180761	SEAL; UHMWPE	4
45	183742	SEAL, piston; UHMWPE	1

Ultra High Molecular Weight Polyethylene Throat Packing Repair Kit 218774. For all pumps.

Ref. No.	Part No.	Description	Qty.
39	180640	GLAND, packing, female	1
40	180641	V-PACKING, UHMWPE	3
41	180639	GLAND, packing, male	1
42	181228	GLAND, seal, UHMWPE	1

PTFE Throat Packing Conversion Kit 218733. For all pumps.

Ref. No.	Part No.	Description	Qty.
39	180640	GLAND, packing, female	1
40	180642	V-PACKING, PTFE	3
41	180639	GLAND, packing, male	1
42	181228	GLAND, seal, UHMWPE	1

Leather Throat Packing Conversion Kit 218734. For all pumps.

Ref. No.	Part No.	Description	Qty.
39	180640	GLAND, packing, female	1
40	180638	V-PACKING; leather	3
41	180639	GLAND, packing, male	1
42	181228	GLAND, seal, UHMWPE	1

UHMWPE/Leather Throat Packing Conversion Kit 237566. For all pumps.

Part No.	Description	Qty.
190274	BEARING, packing, female	1
180638	V-PACKING; leather	3
180641	V-PACKING, UHMWPE	4
180639	GLAND, packing, male	1
181228	GLAND, seal, UHMWPE	1

PTFE/Leather Throat Packing Conversion Kit 237605. For all pumps.

Part No.	Description	Qty.
190274	BEARING, packing, female	1
180638	V-PACKING; leather	3
190298	V-PACKING, PTFE	4
180639	GLAND, packing, male	1
181228	GLAND, seal, UHMWPE	1

Pump Seal Conversion Kit 235855

For Displacement Pumps 218523, 218524, 240592, and 240593
(2:1 Bulldog®, 4:1 King™, Viscount® 400 Pumps)

Part No.	Description	Qty.
180760	SEAL; UHMWPE	4
107545	O-RING;PTFE	4
180758	SEAL; UHMWPE	2
180761	SEAL; UHMWPE	4
112037	SEAL; unfilled PTFE	1

Pump Seal Conversion Kit 235856

For Displacement Pumps 218515, 218516, 240595, and 240596
(3:1 Bulldog®, 6:1 King™, Viscount® 600 Pumps)

Part No.	Description	Qty.
180760	SEAL; UHMWPE	4
107545	O-RING;PTFE	4
180759	SEAL; UHMWPE	2
180761	SEAL; UHMWPE	4
112038	SEAL; unfilled PTFE	1

Pump Seal Conversion Kit 235854

For Displacement Pumps 218530, 218531, 240589, and 240590
(1.5:1 Bulldog®, 3:1 King™, Viscount® 300 Pumps)

Part No.	Description	Qty.
180760	SEAL; UHMWPE	4
107545	O-RING;PTFE	4
180757	SEAL; UHMWPE	2
180761	SEAL; UHMWPE	4
112036	SEAL; unfilled PTFE	1

Technical Data

3:1 Ratio Bulldog Pumps, Models 218511 & 218512

Category	Data
Maximum Fluid Working Pressure	2.1 MPa, 21 bar (300 psi)
Air Operating Range	0.28–0.7 MPa, 2.8 – 7 bar (40 – 100 psi)
Fluid Flow at 60 Cycles per Minute	118 liter/min (31 gpm)
Cycles Per Liter (gallon)	0.5 (1.93)
Maximum Recommended Pump Speed	60 cycles per minute
Wetted parts	<p><i>Model 218511:</i> Carbon Steel, Stainless Steel, PTFE, Ultra High Molecular Weight Polyethylene</p> <p><i>Model 218512:</i> Stainless Steel, PTFE, Ultra High Molecular Weight Polyethylene</p>

Viton® is a registered trademark of the Du Pont Co.

Sound Pressure Levels (dBa) (measured at 1 meter from unit)

Air Motor	Input Air Pressures at 15 cycles per minute		
	40 psi (0.28 MPa, 2.8 bar)	70 psi (0.48 MPa, 4.8 bar)	100 psi (0.7 MPa, 7 bar)
Quiet Bulldog	81.5 dB(A)	83.6 dB(A)	85.8 dB(A)

Sound Power Levels (dBa) (tested in accordance with ISO 9614–2)

Air Motor	Input Air Pressures at 15 cycles per minute		
	40 psi (0.28 MPa, 2.8 bar)	70 psi (0.48 MPa, 4.8 bar)	100 psi (0.7 MPa, 7 bar)
Quiet Bulldog	90.2 dB(A)	93.5 dB(A)	95.3 dB(A)

Performance Charts

To find Fluid Outlet Pressure (psi/MPa/bar) at a specific fluid flow (lpm/gpm) and operating air pressure (psi/MPa/bar):

1. Locate desired flow along bottom of chart.
2. Follow vertical line up to intersection with selected fluid outlet pressure curve (black). Follow left to scale to read fluid outlet pressure.

To find Pump Air Consumption (m³/min or scfm) at a specific fluid flow (lpm/gpm) and air pressure (psi/MPa/bar):

1. Locate desired flow along bottom of chart.
2. Read vertical line up to intersection with selected air consumption curve (dashes). Follow left to scale to read air consumption.

- A 0.7 MPa, 7 bar (100 psi) air pressure
- B 0.49 MPa, 4.9 bar (70 psi) air pressure
- C 0.28 MPa, 2.8 bar (40 psi) air pressure

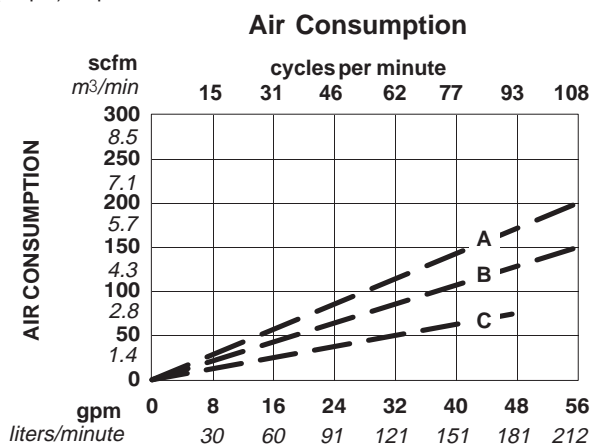
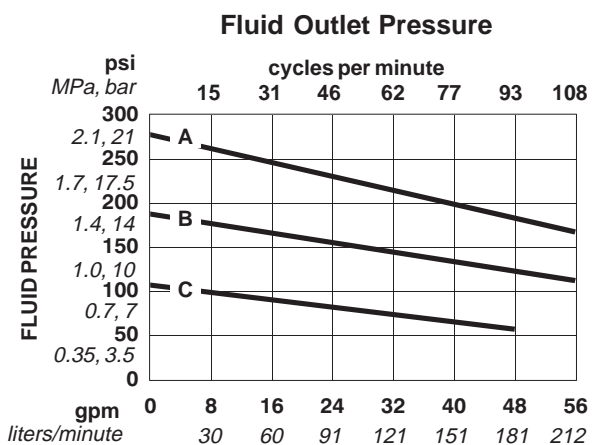

FLUID FLOW (TEST FLUID: NO. 10 WEIGHT OIL)

FLUID FLOW (TEST FLUID: NO. 10 WEIGHT OIL)

Technical Data

2:1 Ratio Bulldog Pumps, Models 218519 & 218520

Category	Data
Maximum Fluid Working Pressure	1.4 MPa, 14 bar (200 psi)
Air Operating Range	0.28–0.7 MPa, 2.8 – 7 bar (40 – 100 psi)
Fluid Flow at 60 Cycles per Minute	178 liter/min (47 gpm)
Cycles Per Liter (gallon)	0.34 (1.3)
Maximum Recommended Pump Speed	60 cycles per minute
Wetted parts	<p><i>Model 218519:</i> Carbon Steel, Stainless Steel, PTFE, Ultra High Molecular Weight Polyethylene</p> <p><i>Model 218520:</i> Stainless Steel, PTFE, Ultra High Molecular Weight Polyethylene</p>

Viton[®] is a registered trademarks of the Du Pont Co.

Sound Pressure Levels (dBa)

(measured at 1 meter from unit)

Air Motor	Input Air Pressures at 15 cycles per minute		
	40 psi (0.28 MPa, 2.8 bar)	70 psi (0.48 MPa, 4.8 bar)	100 psi (0.7 MPa, 7 bar)
Quiet Bulldog	81.5 dB(A)	83.6 dB(A)	85.8 dB(A)

Sound Power Levels (dBa)

(tested in accordance with ISO 9614–2)

Air Motor	Input Air Pressures at 15 cycles per minute		
	40 psi (0.28 MPa, 2.8 bar)	70 psi (0.48 MPa, 4.8 bar)	100 psi (0.7 MPa, 7 bar)
Quiet Bulldog	90.2 dB(A)	93.5 dB(A)	95.3 dB(A)

Performance Charts

To find Fluid Outlet Pressure (psi/MPa/bar) at a specific fluid flow (lpm/gpm) and operating air pressure (psi/MPa/bar):

1. Locate desired flow along bottom of chart.
2. Follow vertical line up to intersection with selected fluid outlet pressure curve (black). Follow left to scale to read fluid outlet pressure.

To find Pump Air Consumption (m³/min or scfm) at a specific fluid flow (lpm/gpm) and air pressure (psi/MPa/bar):

1. Locate desired flow along bottom of chart.
2. Read vertical line up to intersection with selected air consumption curve (dashes). Follow left to scale to read air consumption.

- A 0.7 MPa, 7 bar (100 psi) air pressure
- B 0.49 MPa, 4.9 bar (70 psi) air pressure
- C 0.28 MPa, 2.8 bar (40 psi) air pressure

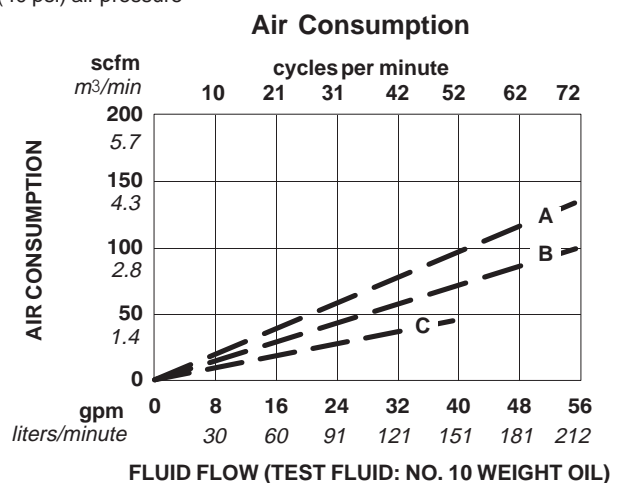
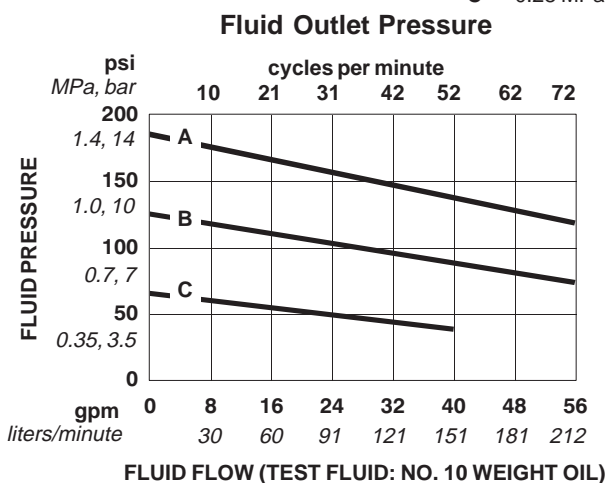

Technical Data

1.5:1 Ratio Bulldog Pumps, Models 218526 & 218527

Category	Data
Maximum Fluid Working Pressure	1.0 MPa, 10 bar (150 psi)
Air Operating Range	0.28–0.7 MPa, 2.8 – 7 bar (40 – 100 psi)
Fluid Flow at 60 Cycles per Minute	237 liter/min (63 gpm)
Cycles Per Liter (gallon)	0.24 (0.93)
Maximum Recommended Pump Speed	60 cycles per minute
Wetted parts	<p><i>Model 218526:</i> Carbon Steel, Stainless Steel, PTFE, Ultra High Molecular Weight Polyethylene</p> <p><i>Model 218527:</i> Stainless Steel, PTFE, Ultra High Molecular Weight Polyethylene</p>

Viton® is a registered trademark of the Du Pont Co.

Sound Pressure Levels (dBa) (measured at 1 meter from unit)

Air Motor	Input Air Pressures at 15 cycles per minute		
	40 psi (0.28 MPa, 2.8 bar)	70 psi (0.48 MPa, 4.8 bar)	100 psi (0.7 MPa, 7 bar)
Quiet Bulldog	81.5 dB(A)	83.6 dB(A)	85.8 dB(A)

Sound Power Levels (dBa) (tested in accordance with ISO 9614–2)

Air Motor	Input Air Pressures at 15 cycles per minute		
	40 psi (0.28 MPa, 2.8 bar)	70 psi (0.48 MPa, 4.8 bar)	100 psi (0.7 MPa, 7 bar)
Quiet Bulldog	90.2 dB(A)	93.5 dB(A)	95.3 dB(A)

Performance Charts

To find Fluid Outlet Pressure (psi/MPa/bar) at a specific fluid flow (lpm/gpm) and operating air pressure (psi/MPa/bar):

1. Locate desired flow along bottom of chart.
2. Follow vertical line up to intersection with selected fluid outlet pressure curve (black). Follow left to scale to read fluid outlet pressure.

To find Pump Air Consumption (m³/min or scfm) at a specific fluid flow (lpm/gpm) and air pressure (psi/MPa/bar):

1. Locate desired flow along bottom of chart.
2. Read vertical line up to intersection with selected air consumption curve (dashes). Follow left to scale to read air consumption.

- A 0.7 MPa, 7 bar (100 psi) air pressure
- B 0.49 MPa, 4.9 bar (70 psi) air pressure
- C 0.28 MPa, 2.8 bar (40 psi) air pressure

Fluid Outlet Pressure

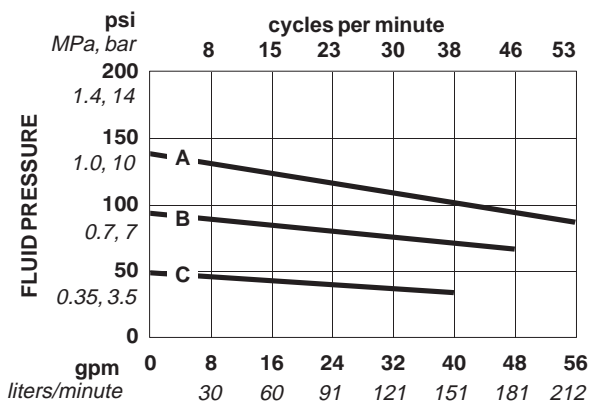

FLUID FLOW (TEST FLUID: NO. 10 WEIGHT OIL)

Air Consumption

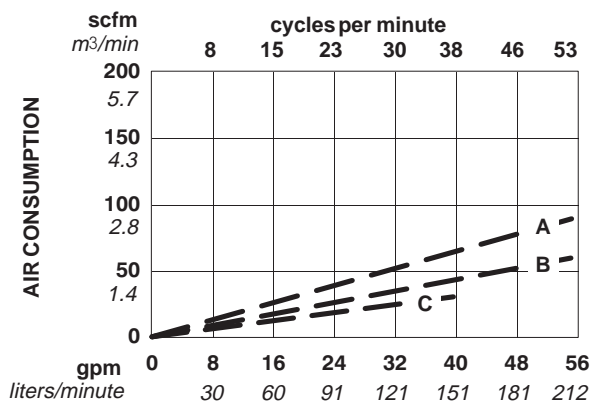

FLUID FLOW (TEST FLUID: NO. 10 WEIGHT OIL)

Technical Data

6:1 Ratio King Pumps, Models 218513 & 218514

Category	Data
Maximum Fluid Working Pressure	3.7 MPa, 37 bar (540 psi)
Air Operating Range	0.28–0.6 MPa, 2.8 – 6.2 bar (40 – 90 psi)
Fluid Flow at 60 Cycles per Minute	118 liter/min (31 gpm)
Cycles Per Liter (gallon)	0.5 (1.93)
Maximum Recommended Pump Speed	60 cycles per minute
Wetted parts	<p><i>Model 218513:</i> Carbon Steel, Stainless Steel, PTFE, Ultra High Molecular Weight Polyethylene</p> <p><i>Model 218514:</i> Stainless Steel, PTFE, Ultra High Molecular Weight Polyethylene</p>

Viton® is a registered trademark of the Du Pont Co.

Sound Pressure Levels (dBa)

(measured at 1 meter from unit)

Air Motor	Input Air Pressures at 15 cycles per minute		
	40 psi (0.28 MPa, 2.8 bar)	70 psi (0.48 MPa, 4.8 bar)	90 psi (0.6 MPa, 6.2 bar)
Quiet King	77.9 dB(A)	79.2 dB(A)	87.5 dB(A)

Sound Power Levels (dBa)

(tested in accordance with ISO 9614–2)

Air Motor	Input Air Pressures at 15 cycles per minute		
	40 psi (0.28 MPa, 2.8 bar)	70 psi (0.48 MPa, 4.8 bar)	90 psi (0.6 MPa, 6.2 bar)
Quiet King	85.2 dB(A)	86.6 dB(A)	95.2 dB(A)

Performance Charts

To find Fluid Outlet Pressure (psi/MPa/bar) at a specific fluid flow (lpm/gpm) and operating air pressure (psi/MPa/bar):

1. Locate desired flow along bottom of chart.
2. Follow vertical line up to intersection with selected fluid outlet pressure curve (black). Follow left to scale to read fluid outlet pressure.

To find Pump Air Consumption (m³/min or scfm) at a specific fluid flow (lpm/gpm) and air pressure (psi/MPa/bar):

1. Locate desired flow along bottom of chart.
2. Read vertical line up to intersection with selected air consumption curve (dashes). Follow left to scale to read air consumption.

- A 0.6 MPa, 6.2 bar (90 psi) air pressure
- B 0.49 MPa, 4.9 bar (70 psi) air pressure
- C 0.28 MPa, 2.8 bar (40 psi) air pressure

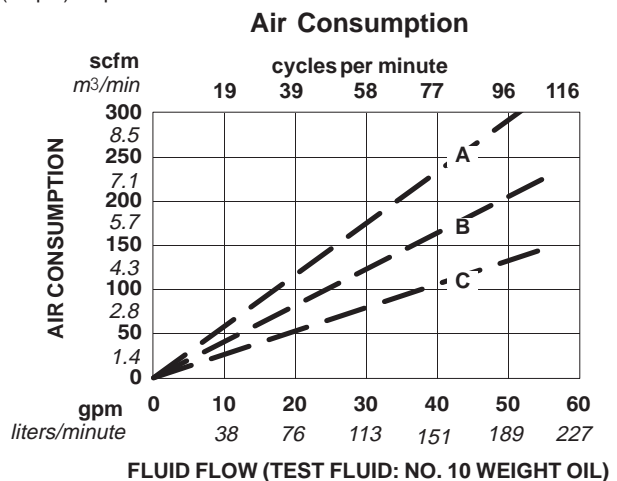
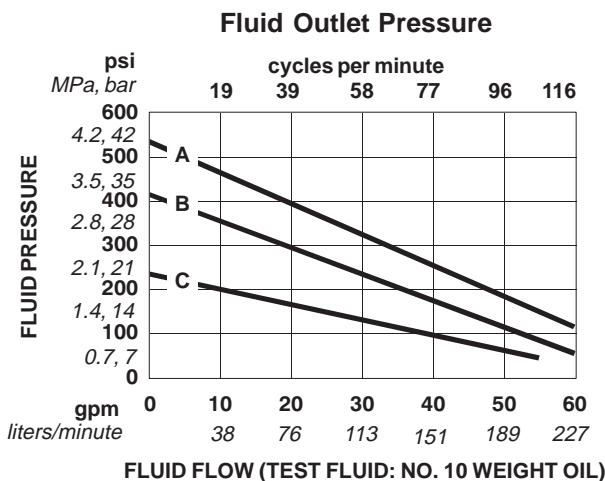

FLUID FLOW (TEST FLUID: NO. 10 WEIGHT OIL)

FLUID FLOW (TEST FLUID: NO. 10 WEIGHT OIL)

Technical Data

4:1 Ratio King Pumps, Models 218521, 218522, 240601, & 240602

Category	Data
Maximum Fluid Working Pressure	2.5 MPa, 25 bar (360 psi)
Air Operating Range	0.28–0.6 MPa, 2.8 – 6.2 bar (40 – 90 psi)
Fluid Flow at 60 Cycles per Minute	178 liter/min (47 gpm)
Cycles Per Liter (gallon)	0.34 (1.3)
Maximum Recommended Pump Speed	60 cycles per minute
Wetted parts	<p><i>Model 218521:</i> Carbon Steel, Stainless Steel, PTFE, Ultra High Molecular Weight Polyethylene</p> <p><i>Models 218522, 240601, and 240602:</i> Stainless Steel, PTFE. Ultra High Molecular Weight Polyethylene</p>

Viton® is a registered trademark of the Du Pont Co.

Sound Pressure Levels (dBa) (measured at 1 meter from unit)

Air Motor	Input Air Pressures at 15 cycles per minute		
	40 psi (0.28 MPa, 2.8 bar)	70 psi (0.48 MPa, 4.8 bar)	90 psi (0.6 MPa, 6.2 bar)
Quiet King	77.9 dB(A)	79.2 dB(A)	87.5 dB(A)

Sound Power Levels (dBa) (tested in accordance with ISO 9614–2)

Air Motor	Input Air Pressures at 15 cycles per minute		
	40 psi (0.28 MPa, 2.8 bar)	70 psi (0.48 MPa, 4.8 bar)	90 psi (0.6 MPa, 6.2 bar)
Quiet King	85.2 dB(A)	86.6 dB(A)	95.2 dB(A)

Performance Charts

To find Fluid Outlet Pressure (psi/MPa/bar) at a specific fluid flow (lpm/gpm) and operating air pressure (psi/MPa/bar):

1. Locate desired flow along bottom of chart.
2. Follow vertical line up to intersection with selected fluid outlet pressure curve (black). Follow left to scale to read fluid outlet pressure.

To find Pump Air Consumption (m³/min or scfm) at a specific fluid flow (lpm/gpm) and air pressure (psi/MPa/bar):

1. Locate desired flow along bottom of chart.
2. Read vertical line up to intersection with selected air consumption curve (dashes). Follow left to scale to read air consumption.

- A 0.6 MPa, 6.2 bar (90 psi) air pressure
- B 0.49 MPa, 4.9 bar (70 psi) air pressure
- C 0.28 MPa, 2.8 bar (40 psi) air pressure

Fluid Outlet Pressure

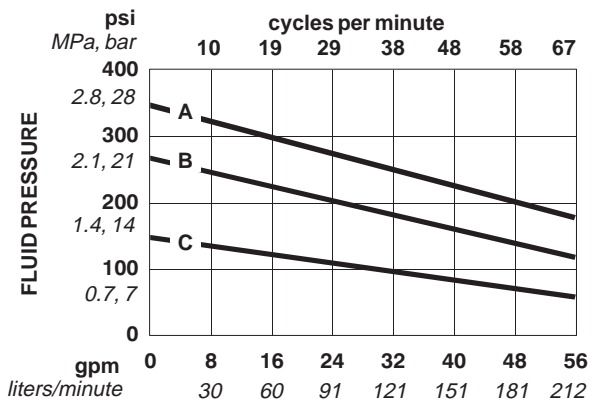

FLUID FLOW (TEST FLUID: NO. 10 WEIGHT OIL)

Air Consumption

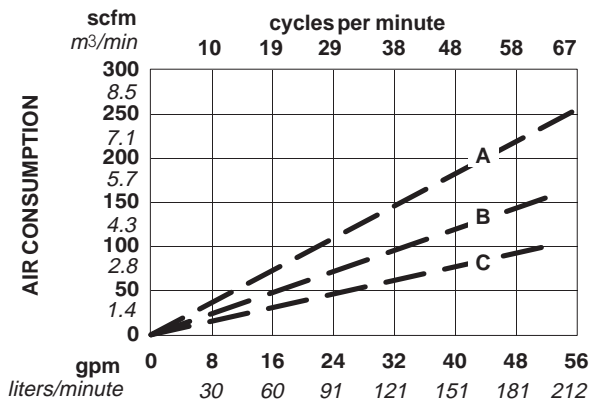

FLUID FLOW (TEST FLUID: NO. 10 WEIGHT OIL)

Technical Data

3:1 Ratio King Pumps, Models 218528, 218529, 240598, & 240599

Category	Data
Maximum Fluid Working Pressure	1.9 MPa, 19 bar (270 psi)
Air Operating Range	0.28–0.6 MPa, 2.8 – 6.2 bar (40 – 90 psi)
Fluid Flow at 60 Cycles per Minute	237 liter/min (63 gpm)
Cycles Per Liter (gallon)	0.24 (0.93)
Maximum Recommended Pump Speed	60 cycles per minute
Wetted parts	<i>Model 218528:</i> Carbon Steel, Stainless Steel, PTFE, Ultra High Molecular Weight Polyethylene <i>Models 218529, 240598, and 240599:</i> Stainless Steel, PTFE, Ultra High Molecular Weight Polyethylene

Viton® is a registered trademark of the Du Pont Co.

Sound Pressure Levels (dBa) (measured at 1 meter from unit)

Air Motor	Input Air Pressures at 15 cycles per minute		
	40 psi (0.28 MPa, 2.8 bar)	70 psi (0.48 MPa, 4.8 bar)	90 psi (0.6 MPa, 6.2 bar)
Quiet King	77.9 dB(A)	79.2 dB(A)	87.5 dB(A)

Sound Power Levels (dBa) (tested in accordance with ISO 9614–2)

Air Motor	Input Air Pressures at 15 cycles per minute		
	40 psi (0.28 MPa, 2.8 bar)	70 psi (0.48 MPa, 4.8 bar)	90 psi (0.6 MPa, 6.2 bar)
Quiet King	85.2 dB(A)	86.6 dB(A)	95.2 dB(A)

Performance Charts

To find Fluid Outlet Pressure (psi/MPa/bar) at a specific fluid flow (lpm/gpm) and operating air pressure (psi/MPa/bar):

1. Locate desired flow along bottom of chart.
2. Follow vertical line up to intersection with selected fluid outlet pressure curve (black). Follow left to scale to read fluid outlet pressure.

To find Pump Air Consumption (m³/min or scfm) at a specific fluid flow (lpm/gpm) and air pressure (psi/MPa/bar):

1. Locate desired flow along bottom of chart.
2. Read vertical line up to intersection with selected air consumption curve (dashes). Follow left to scale to read air consumption.

- A 0.6 MPa, 6.2 bar (90 psi) air pressure
- B 0.49 MPa, 4.9 bar (70 psi) air pressure
- C 0.28 MPa, 2.8 bar (40 psi) air pressure

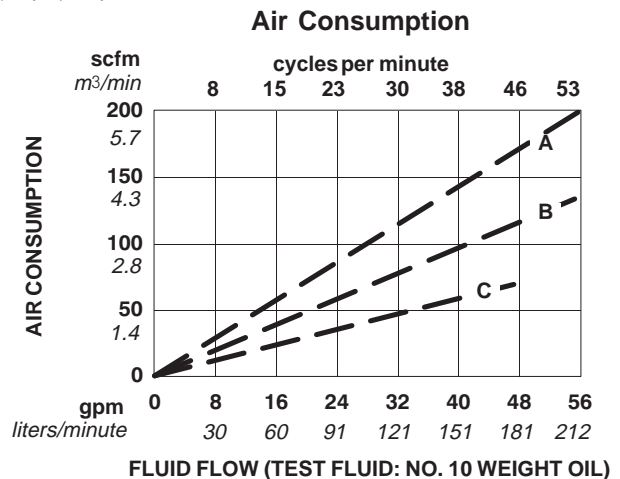
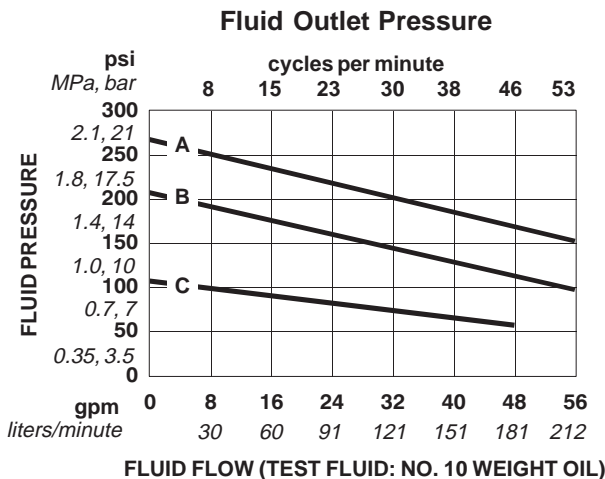

Technical Data

Viscount II 600 Pumps, Models 218533 & 218534

Category	Data
Maximum Fluid Working Pressure	4.1 MPa, 41 bar (600 psi)
Maximum Hydraulic Fluid Pressure	10.3 MPa, 103 bar (1500 psi)
Fluid Flow at 60 Cycles per Minute	118 liter/min (31 gpm)
Cycles Per Liter (gallon)	0.5 (1.93)
Maximum Recommended Pump Speed	60 cycles per minute
Maximum Hydraulic Motor Fluid Temperature	54°C (134°F)
Wetted parts	<p><i>Model 218533:</i> Carbon Steel, Stainless Steel, PTFE, Ultra High Molecular Weight Polyethylene</p> <p><i>Model 218534:</i> Stainless Steel, PTFE, Ultra High Molecular Weight Polyethylene</p>

Viton® is a registered trademark of the Du Pont Co.

Performance Charts

To find Fluid Outlet Pressure (psi/MPa/bar) at a specific fluid flow (lpm/gpm) and operating hydraulic pressure (psi/MPa/bar):

1. Locate desired flow along bottom of chart.
2. Follow vertical line up to intersection with selected fluid outlet pressure curve (black). Follow left to scale to read fluid outlet pressure.

To find Motor Hydraulic Oil Consumption (l/min or gpm) at a specific fluid flow (l/min or gpm):

1. Locate desired flow along bottom of chart.
2. Read vertical line up to intersection with hydraulic oil consumption curve (dashes). Follow left to scale to read hydraulic oil consumption.

- A 10.3 MPa, 103 bar (1500 psi) hydraulic pressure
- B 7.2 MPa, 72.4 bar (1050 psi) hydraulic pressure
- C 4.1 MPa, 41 bar (600 psi) hydraulic pressure

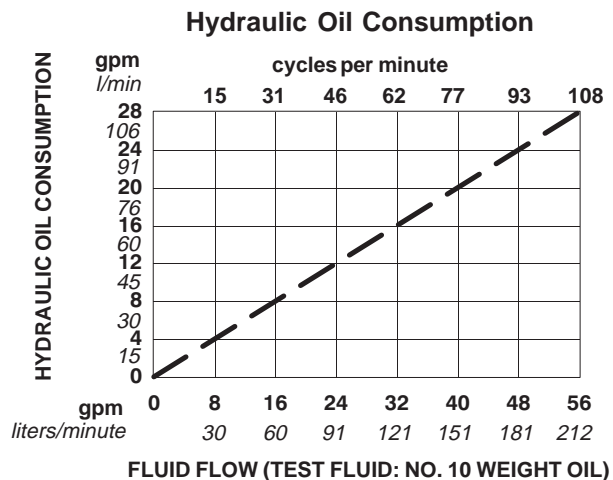
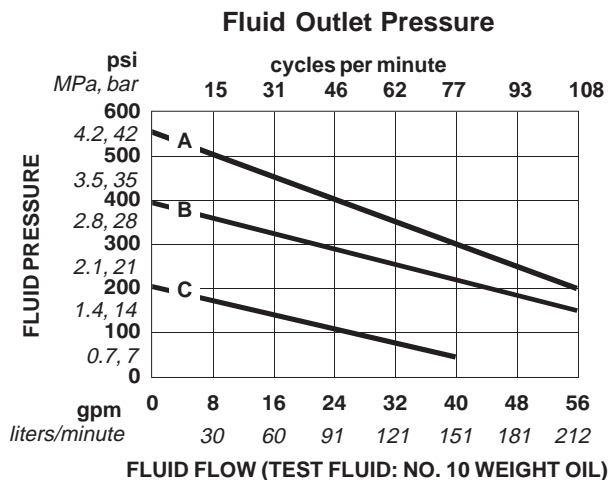

Technical Data

Viscount II 400 Pumps, Models 218535 & 218536

Category	Data
Maximum Fluid Working Pressure	2.8 MPa, 28 bar (400 psi)
Maximum Hydraulic Fluid Pressure	10.3 MPa, 103 bar (1500 psi)
Fluid Flow at 60 Cycles per Minute	178 liter/min (47 gpm)
Cycles Per Liter (gallon)	0.34 (1.3)
Maximum Recommended Pump Speed	60 cycles per minute
Maximum Hydraulic Motor Fluid Temperature	54°C (134°F)
Wetted parts	<p><i>Model 218535:</i> Carbon Steel, Stainless Steel, PTFE, Ultra High Molecular Weight Polyethylene</p> <p><i>Model 218536:</i> Stainless Steel, PTFE, Ultra High Molecular Weight Polyethylene</p>

Viton® is a registered trademarks of the Du Pont Co.

Performance Charts

To find Fluid Outlet Pressure (psi/MPa/bar) at a specific fluid flow (lpm/gpm) and operating hydraulic pressure (psi/MPa/bar):

1. Locate desired flow along bottom of chart.
2. Follow vertical line up to intersection with selected fluid outlet pressure curve (black). Follow left to scale to read fluid outlet pressure.

To find Motor Hydraulic Oil Consumption (l/min or gpm) at a specific fluid flow (l/min or gpm):

1. Locate desired flow along bottom of chart.
2. Read vertical line up to intersection with hydraulic oil consumption curve (dashes). Follow left to scale to read hydraulic oil consumption.

- A 10.3 MPa, 103 bar (1500 psi) hydraulic pressure
- B 7.2 MPa, 72.4 bar (1050 psi) hydraulic pressure
- C 4.1 MPa, 41 bar (600 psi) hydraulic pressure

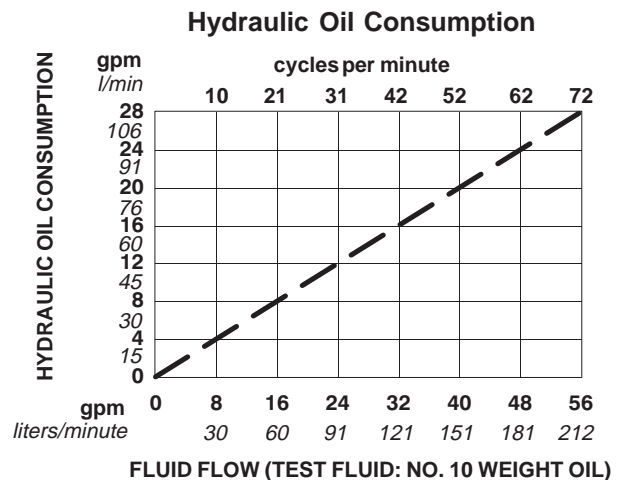
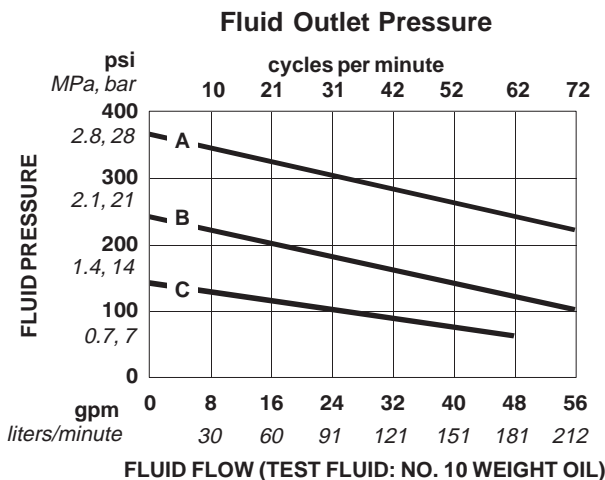

Technical Data

Viscount II 300 Pumps, Models 218537 & 218538

Category	Data
Maximum Fluid Working Pressure	2.1 MPa, 21 bar (300 psi)
Maximum Hydraulic Fluid Pressure	10.3 MPa, 103 bar (1500 psi)
Fluid Flow at 60 Cycles per Minute	237 liter/min (63 gpm)
Cycles Per Liter (gallon)	0.24 (0.93)
Maximum Recommended Pump Speed	60 cycles per minute
Maximum Hydraulic Motor Fluid Temperature	54°C (134°F)
Wetted parts	<p><i>Model 218537:</i> Carbon Steel, Stainless Steel, PTFE, Ultra High Molecular Weight Polyethylene</p> <p><i>Model 218538:</i> Stainless Steel, PTFE, Ultra High Molecular Weight Polyethylene</p>

Viton® is a registered trademark of the Du Pont Co.

Performance Charts

To find Fluid Outlet Pressure (psi/MPa/bar) at a specific fluid flow (lpm/gpm) and operating hydraulic pressure (psi/MPa/bar):

1. Locate desired flow along bottom of chart.
2. Follow vertical line up to intersection with selected fluid outlet pressure curve (black). Follow left to scale to read fluid outlet pressure.

To find Motor Hydraulic Oil Consumption (l/min or gpm) at a specific fluid flow (l/min or gpm):

1. Locate desired flow along bottom of chart.
2. Read vertical line up to intersection with hydraulic oil consumption curve (dashes). Follow left to scale to read hydraulic oil consumption.

- A** 10.3 MPa, 103 bar (1500 psi) hydraulic pressure
B 7.2 MPa, 72.4 bar (1050 psi) hydraulic pressure
C 4.1 MPa, 41 bar (600 psi) hydraulic pressure

Fluid Outlet Pressure

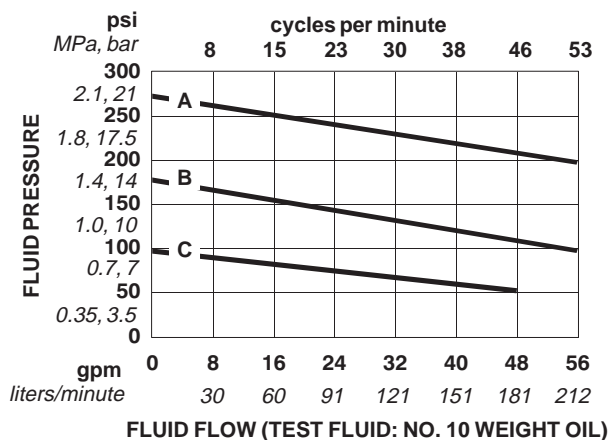

Hydraulic Oil Consumption

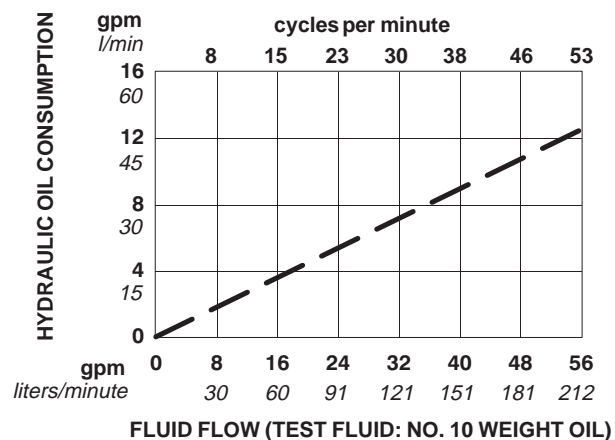

Technical Data

1.8:1 Ratio Senator Pump

Category	Data
Maximum Fluid Working Pressure	1.2 MPa, 12 bar (180 psi)
Air Operating Range	0.28–0.7 MPa, 2.8 – 7 bar (40 – 100 psi)
Fluid Flow at 60 Cycles per Minute	118 liter/min (31 gpm)
Cycles Per Liter (gallon)	0.34 (1.3)
Maximum Recommended Pump Speed	60 cycles per minute
Wetted parts	Carbon Steel, Stainless Steel, PTFE, Ultra High Molecular Weight Polyethylene OR Stainless Steel, PTFE, Ultra High Molecular Weight Polyethylene

Viton® is a registered trademark of the Du Pont Co.

Sound Pressure Levels (dBa) (measured at 1 meter from unit)

Air Motor	Input Air Pressures at 15 cycles per minute		
	40 psi (0.28 MPa, 2.8 bar)	70 psi (0.48 MPa, 4.8 bar)	100 psi (0.7 MPa, 7 bar)
Quiet Senator	83.4 dB(A)	84.3 dB(A)	88.5 dB(A)

Sound Power Levels (dBa) (tested in accordance with ISO 9614–2)

Air Motor	Input Air Pressures at 15 cycles per minute		
	40 psi (0.28 MPa, 2.8 bar)	70 psi (0.48 MPa, 4.8 bar)	100 psi (0.7 MPa, 7 bar)
Quiet Senator	89.8 dB(A)	91.8 dB(A)	94.4 dB(A)

Performance Charts

To find Fluid Outlet Pressure (psi/MPa/bar) at a specific fluid flow (lpm/gpm) and operating air pressure (psi/MPa/bar):

1. Locate desired flow along bottom of chart.
2. Follow vertical line up to intersection with selected fluid outlet pressure curve (black). Follow left to scale to read fluid outlet pressure.

To find Pump Air Consumption (m³/min or scfm) at a specific fluid flow (lpm/gpm) and air pressure (psi/MPa/bar):

1. Locate desired flow along bottom of chart.
2. Read vertical line up to intersection with selected air consumption curve (dashes). Follow left to scale to read air consumption.

- A 0.7 MPa, 7 bar (100 psi) air pressure
 B 0.49 MPa, 4.9 bar (70 psi) air pressure
 C 0.28 MPa, 2.8 bar (40 psi) air pressure

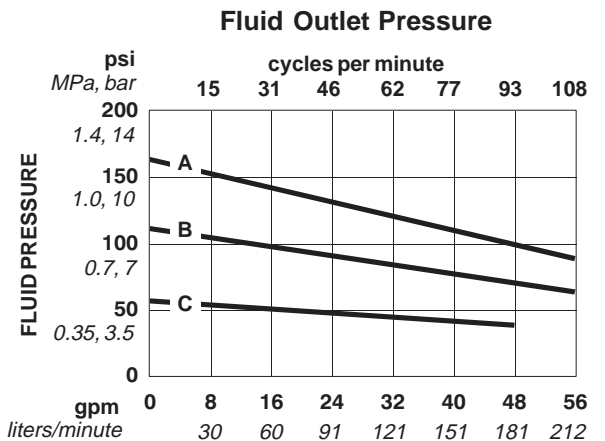

FLUID FLOW (TEST FLUID: NO. 10 WEIGHT OIL)

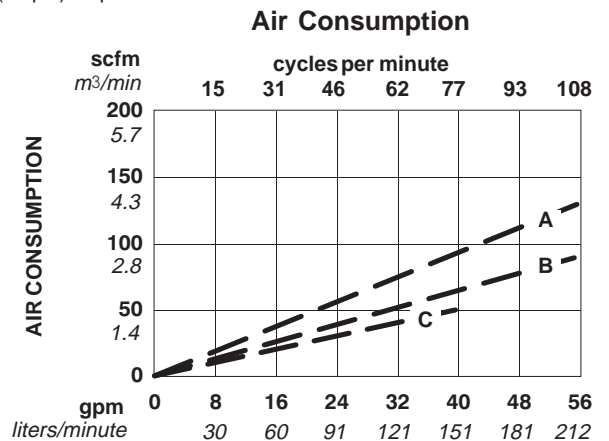

FLUID FLOW (TEST FLUID: NO. 10 WEIGHT OIL)

Technical Data

1:1 Ratio Senator Pump

Category	Data
Maximum Fluid Working Pressure	0.7 MPa, 7 bar (100 psi)
Air Operating Range	0.28–0.7 MPa, 2.8 – 7 bar (40 – 100 psi)
Fluid Flow at 60 Cycles per Minute	178 liter/min (47 gpm)
Cycles Per Liter (gallon)	0.5 (1.93)
Maximum Recommended Pump Speed	60 cycles per minute
Wetted parts	Carbon Steel, Stainless Steel, PTFE, Ultra High Molecular Weight Polyethylene OR Stainless Steel, PTFE, Ultra High Molecular Weight Polyethylene

Viton[®] is a registered trademark of the Du Pont Co.

Sound Pressure Levels (dBA) (measured at 1 meter from unit)

Air Motor	Input Air Pressures at 15 cycles per minute		
	40 psi (0.28 MPa, 2.8 bar)	70 psi (0.48 MPa, 4.8 bar)	100 psi (0.7 MPa, 7 bar)
Quiet Senator	83.4 dB(A)	84.3 dB(A)	88.5 dB(A)

Sound Power Levels (dBa) (tested in accordance with ISO 9614–2)

Air Motor	Input Air Pressures at 15 cycles per minute		
	40 psi (0.28 MPa, 2.8 bar)	70 psi (0.48 MPa, 4.8 bar)	100 psi (0.7 MPa, 7 bar)
Quiet Senator	89.8 dB(A)	91.8 dB(A)	94.4 dB(A)

Performance Charts

To find Fluid Outlet Pressure (psi/MPa/bar) at a specific fluid flow (lpm/gpm) and operating air pressure (psi/MPa/bar):

1. Locate desired flow along bottom of chart.
2. Follow vertical line up to intersection with selected fluid outlet pressure curve (black). Follow left to scale to read fluid outlet pressure.

To find Pump Air Consumption (m³/min or scfm) at a specific fluid flow (lpm/gpm) and air pressure (psi/MPa/bar):

1. Locate desired flow along bottom of chart.
2. Read vertical line up to intersection with selected air consumption curve (dashes). Follow left to scale to read air consumption.

- A 0.7 MPa, 7 bar (100 psi) air pressure
 B 0.49 MPa, 4.9 bar (70 psi) air pressure
 C 0.28 MPa, 2.8 bar (40 psi) air pressure

Fluid Outlet Pressure

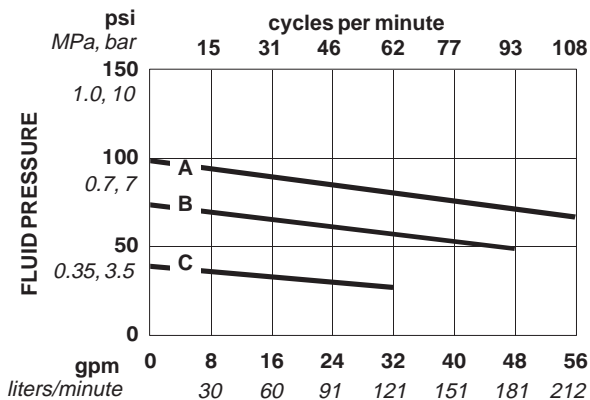

FLUID FLOW (TEST FLUID: NO. 10 WEIGHT OIL)

Air Consumption

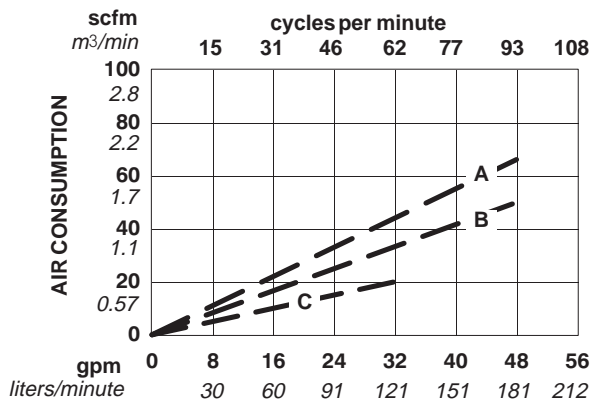

FLUID FLOW (TEST FLUID: NO. 10 WEIGHT OIL)

Technical Data

0.7:1 Ratio Senator Pump

Category	Data
Maximum Fluid Working Pressure	0.49 MPa, 4.9 bar (70 psi)
Air Operating Range	0.28–0.7 MPa, 2.8 – 7 bar (40 – 100 psi)
Fluid Flow at 60 Cycles per Minute	237 liter/min (63 gpm)
Cycles Per Liter (gallon)	0.5 (1.93)
Maximum Recommended Pump Speed	60 cycles per minute
Wetted parts	Carbon Steel, Stainless Steel, PTFE, Ultra High Molecular Weight Polyethylene OR Stainless Steel, PTFE, Ultra High Molecular Weight Polyethylene

Viton® is a registered trademark of the Du Pont Co.

Sound Pressure Levels (dBa) (measured at 1 meter from unit)

Air Motor	Input Air Pressures at 15 cycles per minute		
	40 psi (0.28 MPa, 2.8 bar)	70 psi (0.48 MPa, 4.8 bar)	100 psi (0.7 MPa, 7 bar)
Quiet Senator	83.4 dB(A)	84.3 dB(A)	88.5 dB(A)

Sound Power Levels (dBa) (tested in accordance with ISO 9614–2)

Air Motor	Input Air Pressures at 15 cycles per minute		
	40 psi (0.28 MPa, 2.8 bar)	70 psi (0.48 MPa, 4.8 bar)	100 psi (0.7 MPa, 7 bar)
Quiet Senator	89.8 dB(A)	91.8 dB(A)	94.4 dB(A)

Performance Charts

To find Fluid Outlet Pressure (psi/MPa/bar) at a specific fluid flow (lpm/gpm) and operating air pressure (psi/MPa/bar):

1. Locate desired flow along bottom of chart.
2. Follow vertical line up to intersection with selected fluid outlet pressure curve (black). Follow left to scale to read fluid outlet pressure.

To find Pump Air Consumption (m³/min or scfm) at a specific fluid flow (lpm/gpm) and air pressure (psi/MPa/bar):

1. Locate desired flow along bottom of chart.
2. Read vertical line up to intersection with selected air consumption curve (dashes). Follow left to scale to read air consumption.

- A 0.7 MPa, 7 bar (100 psi) air pressure
 B 0.49 MPa, 4.9 bar (70 psi) air pressure
 C 0.28 MPa, 2.8 bar (40 psi) air pressure

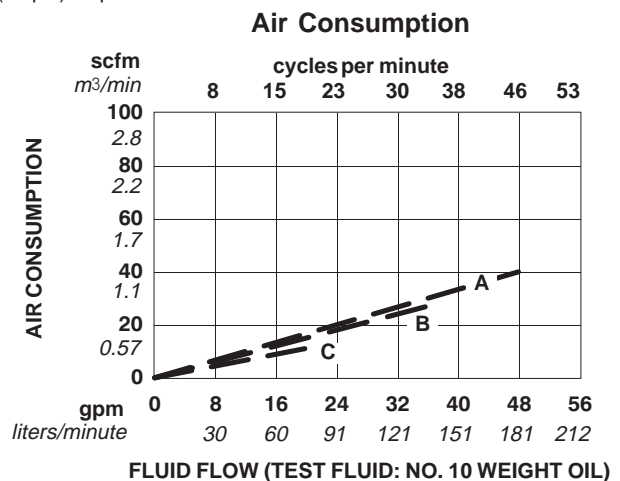
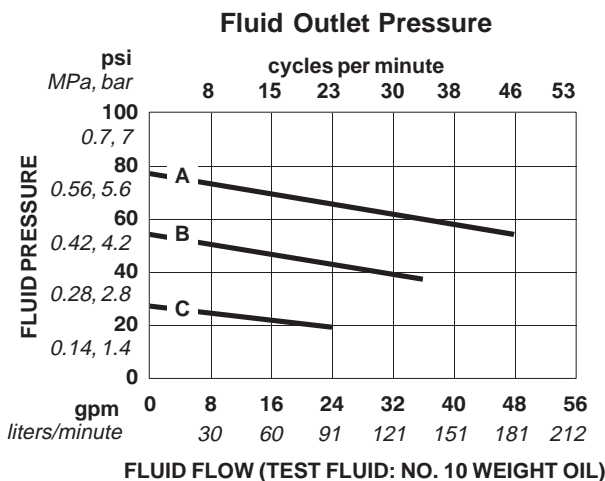

Dimensions

- 1 Viscount Motors have a 3/4 npt hydraulic inlet and a 1 in. npt hydraulic outlet.
- 2 Models 240598/599 and 240601/602: 2" bsp(f)
- 3 Models 240598 and 240601 include tri-clamp adapters

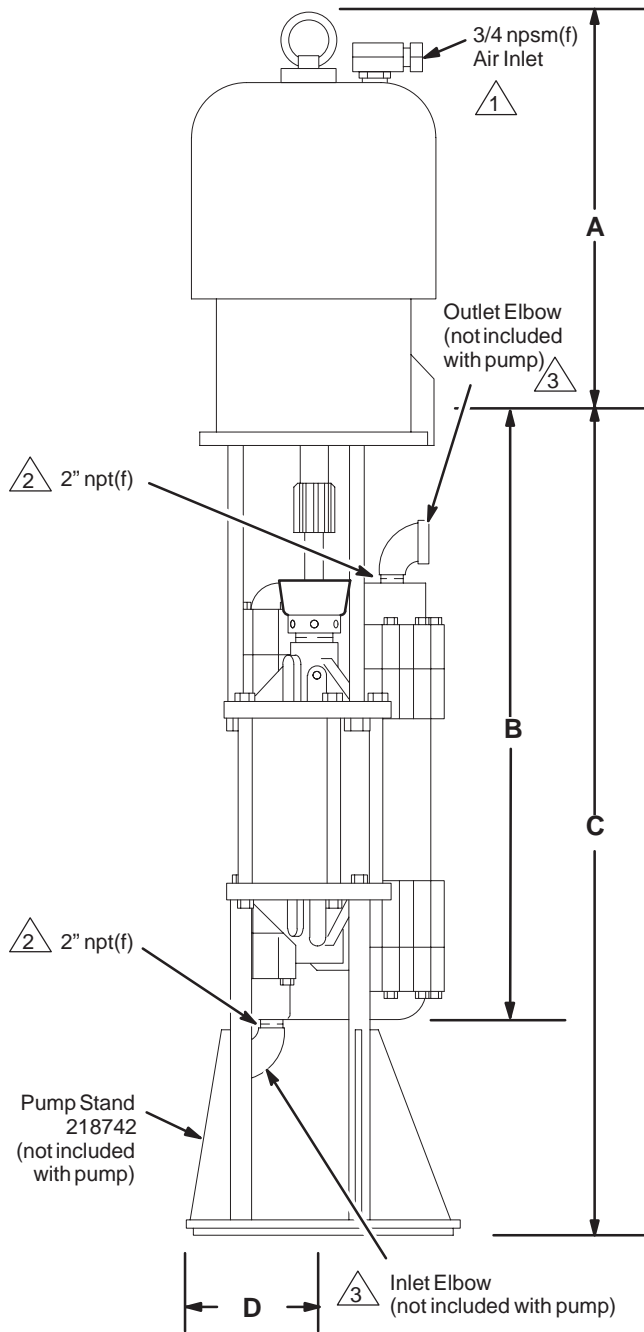

01426

Mounting Stand Hole Layout

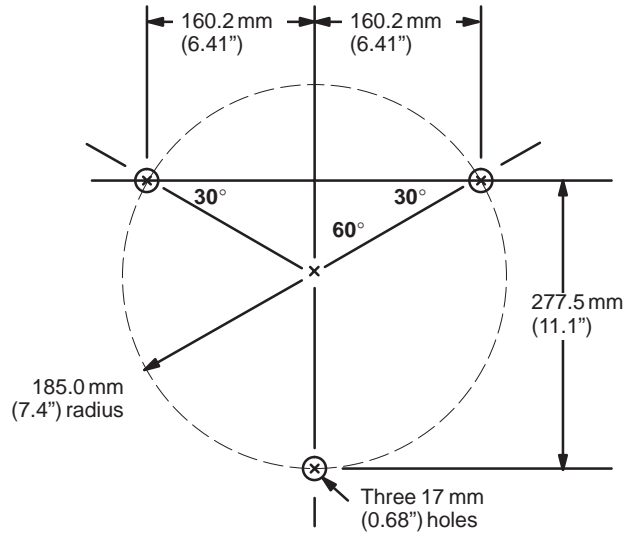

Pump Model	A	B	C	D	Weight
Bulldog	540 mm (21.25")	732 mm (29.28")	1003 mm (40")	205 mm (8.2")	75 kg (167 lb)
King	540 mm (21.25")	732 mm (29.28")	1003 mm (40")	205 mm (8.2")	84 kg (187 lb)
Model 240598/599 & 240601/602 King	540 mm (21.25")	754 mm (30.16")	1025 mm (40.88")	205 mm (8.2")	84 kg (187 lb)
Viscount	633 mm (24.94")	732 mm (29.28")	1003 mm (40")	205 mm (8.2")	98 kg (217 lb)
Senator	546 mm (21.50")	732 mm (29.28")	1003 mm (40")	205 mm (8.2")	71 kg (158 lb)

The Graco Standard Warranty

Graco warrants all equipment manufactured by Graco and bearing its name to be free from defects in material and workmanship on the date of sale by an authorized Graco distributor to the original purchaser for use. With the exception of any special, extended, or limited warranty published by Graco, Graco will, for a period of twelve months from the date of sale, repair or replace any part of the equipment determined by Graco to be defective. This warranty applies only when the equipment is installed, operated and maintained in accordance with Graco's written recommendations.

This warranty does not cover, and Graco shall not be liable for general wear and tear, or any malfunction, damage or wear caused by faulty installation, misapplication, abrasion, corrosion, inadequate or improper maintenance, negligence, accident, tampering, or substitution of non-Graco component parts. Nor shall Graco be liable for malfunction, damage or wear caused by the incompatibility of Graco equipment with structures, accessories, equipment or materials not supplied by Graco, or the improper design, manufacture, installation, operation or maintenance of structures, accessories, equipment or materials not supplied by Graco.

This warranty is conditioned upon the prepaid return of the equipment claimed to be defective to an authorized Graco distributor for verification of the claimed defect. If the claimed defect is verified, Graco will repair or replace free of charge any defective parts. The equipment will be returned to the original purchaser transportation prepaid. If inspection of the equipment does not disclose any defect in material or workmanship, repairs will be made at a reasonable charge, which charges may include the costs of parts, labor, and transportation.

THIS WARRANTY IS EXCLUSIVE, AND IS IN LIEU OF ANY OTHER WARRANTIES, EXPRESS OR IMPLIED, INCLUDING BUT NOT LIMITED TO WARRANTY OF MERCHANTABILITY OR WARRANTY OF FITNESS FOR A PARTICULAR PURPOSE.

Graco's sole obligation and buyer's sole remedy for any breach of warranty shall be as set forth above. The buyer agrees that no other remedy (including, but not limited to, incidental or consequential damages for lost profits, lost sales, injury to person or property, or any other incidental or consequential loss) shall be available. Any action for breach of warranty must be brought within two (2) years of the date of sale.

Graco makes no warranty, and disclaims all implied warranties of merchantability and fitness for a particular purpose in connection with accessories, equipment, materials or components sold but not manufactured by Graco. These items sold, but not manufactured by Graco (such as electric motors, switches, hose, etc.), are subject to the warranty, if any, of their manufacturer. Graco will provide purchaser with reasonable assistance in making any claim for breach of these warranties.

In no event will Graco be liable for indirect, incidental, special or consequential damages resulting from Graco supplying equipment hereunder, or the furnishing, performance, or use of any products or other goods sold hereto, whether due to a breach of contract, breach of warranty, the negligence of Graco, or otherwise.

FOR GRACO CANADA CUSTOMERS

The parties acknowledge that they have required that the present document, as well as all documents, notices and legal proceedings entered into, given or instituted pursuant hereto or relating directly or indirectly hereto, be drawn up in English. Les parties reconnaissent avoir convenu que la rédaction du présente document sera en Anglais, ainsi que tous documents, avis et procédures judiciaires exécutés, donnés ou intentés à la suite de ou en rapport, directement ou indirectement, avec les procédures concernées.

Graco Phone Number

TO PLACE AN ORDER, contact your Graco distributor, or call this number to identify the distributor closest to you:
1-800-367-4023 Toll Free

*All written and visual data contained in this document reflects the latest product information available at the time of publication.
Graco reserves the right to make changes at any time without notice.*

Sales Offices: Minneapolis, Detroit

Foreign Offices: Belgium, England, Korea, France, Germany, Hong Kong, Japan

GRACO INC. P.O. BOX 1441 MINNEAPOLIS, MN 55440-1441

www.graco.com

PRINTED IN U.S.A. 307678 September 1984 Revised March 1999