

5 Gallon Duo Paint Sprayer

306713N

A portable one or two gun circulating supply package.

*360 psi (25 bar) Maximum Working Pressure
180 psi (12 bar) Maximum Air Inlet Pressure*

Part No. 205585, Series D

With Agitator



II 1/2 G T6
ITS03ATEX11251

Part No. 205584, Series A

Without Agitator



II 1/2 G T6
ITS03ATEX11251

Part No. 205595, Series E

Bare Pump Assembly



II 1/2 G T6
ITS03ATEX11227



Important Safety Instructions.

Read all warnings and instructions in this manual. Save these instructions. See page 2 for Table of Contents

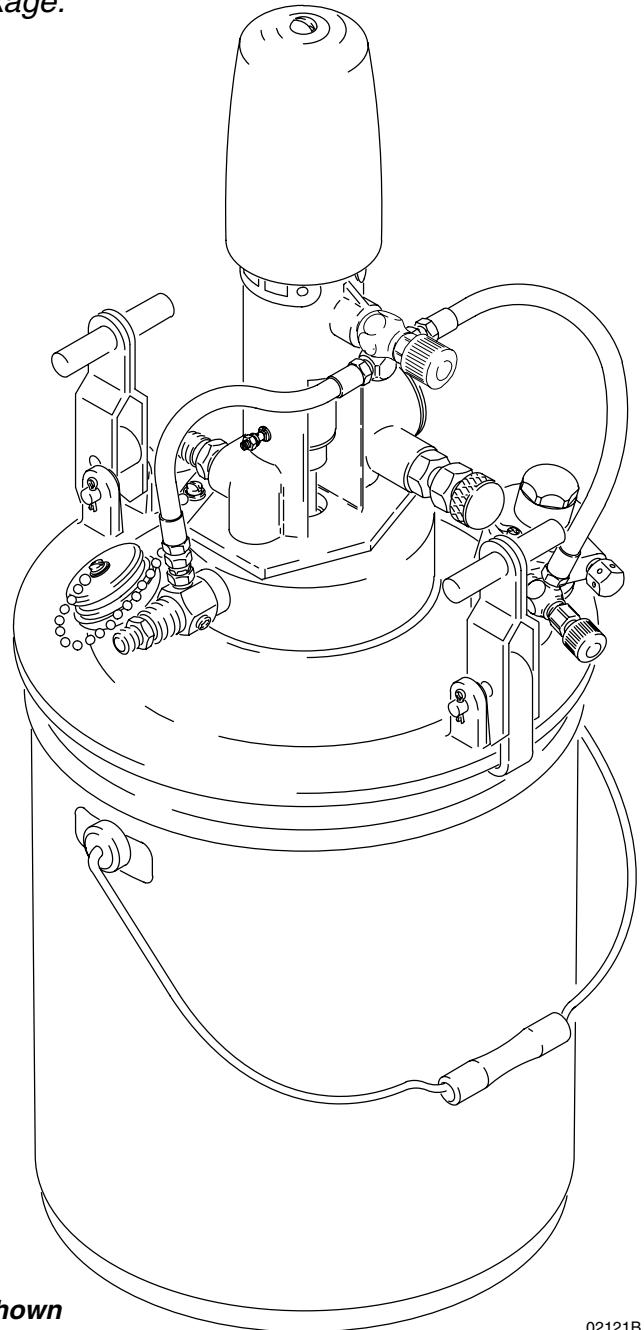

Model 205585 Shown

02121B

Table of Contents

| | |
|-------------------------|----|
| Warnings | 2 |
| Setup | 4 |
| Operation | 8 |
| Troubleshooting | 14 |
| Service | 14 |
| Parts | 18 |
| Technical Data | 22 |
| Dimensions | 23 |
| Graco Warranty | 24 |
| Graco Information | 24 |

Symbols

Warning Symbol



This symbol alerts you to the possibility of serious injury or death if you do not follow the instructions.

Caution Symbol



This symbol alerts you to the possibility of damage to or destruction of equipment if you do not follow the instructions.

! WARNING



INSTRUCTIONS

EQUIPMENT MISUSE HAZARD

Equipment misuse can cause the equipment to rupture or malfunction and result in serious injury.

- This equipment is for professional use only.
- Read all instruction manuals, tags, and labels before operating the equipment.
- Use the equipment only for its intended purpose. If you are not sure, call your Graco distributor.
- Do not alter or modify this equipment.
- Check equipment daily. Repair or replace worn or damaged parts immediately.
- Do not exceed the maximum working pressure of the lowest rated system component. Refer to the **Technical Data** on page 22 for the maximum working pressure of this equipment.
- Use fluids and solvents which are compatible with the equipment wetted parts. Refer to the **Technical Data** section of all equipment manuals. Read the fluid and solvent manufacturer's warnings.
- Do not use 1,1,1-trichloroethane, methylene chloride, other halogenated hydrocarbon solvents or fluids containing such solvents in aluminum equipment. Such use could result in a serious chemical reaction, with the possibility of explosion.
- Do not use hoses to pull equipment.
- Route hoses away from traffic areas, sharp edges, moving parts, and hot surfaces. Do not expose Graco hoses to temperatures above 82°C (180°F) or below -40°C (-40°F).
- Wear hearing protection when operating this equipment.
- Do not lift pressurized equipment.
- Comply with all applicable local, state, and national fire, electrical, and safety regulations.

WARNING



FIRE AND EXPLOSION HAZARD

Improper grounding, poor ventilation, open flames or sparks can cause a hazardous condition and result in a fire or explosion and serious injury.

- Ground the equipment and the object being sprayed. Refer to **Grounding** on page 4.
- If there is any static sparking or you feel an electric shock while using this equipment, **stop spraying immediately**. Do not use the equipment until you identify and correct the problem.
- Provide fresh air ventilation to avoid the buildup of flammable fumes from solvents or the fluid being sprayed.
- Keep the spray area free of debris, including solvent, rags, and gasoline.
- Electrically disconnect all equipment in the spray area.
- Extinguish all open flames or pilot lights in the spray area.
- Do not smoke in the spray area.
- Do not turn on or off any light switch in the spray area while operating or if fumes are present.
- Do not operate a gasoline engine in the spray area.



TOXIC FLUID HAZARD

Hazardous fluid or toxic fumes can cause serious injury or death if splashed in the eyes or on the skin, inhaled, or swallowed.

- Know the specific hazards of the fluid you are using.
- Store hazardous fluid in an approved container. Dispose of hazardous fluid according to all local, state and national guidelines.
- Always wear protective eyewear, gloves, clothing and respirator as recommended by the fluid and solvent manufacturer.



MOVING PARTS HAZARD

Moving parts, such as the air motor piston, can pinch or amputate your fingers.

- Keep clear of all moving parts when starting or operating the pump.
- Before servicing the equipment, follow the **Pressure Relief Procedure** on page 8 to prevent the equipment from starting unexpectedly.

Setup

NOTE: Reference numbers and letters in parentheses in the text refer to the callouts in the figures and the parts drawing.

Prepare the Operator

All persons who operate the equipment must be trained in the safe, efficient operation of all system components as well as the proper handling of all fluids. All operators must thoroughly read all instruction manuals, tags, and labels before operating the equipment.

Prepare the Site

The pump requires 3.75 scfm (0.105 m³/min) of compressed air while operating at 100 psi (7 bar) air pressure and 60 cycles per minute. Ensure that you have an adequate compressed air supply.

Refer to Fig. 2. Bring a compressed air supply line (D) from the air compressor to the pump location. Be sure all air hoses (F) are properly sized and pressure-rated for your system. Use only electrically conductive hoses.

Keep the site clear of any obstacles or debris that could interfere with the operator's movement.

Have a grounded, metal pail available for use when flushing the system or draining the fluid filter.

Grounding

| | |
|--|--|
| ⚠ WARNING | |
|  | FIRE AND EXPLOSION HAZARD Before operating the pump, ground the system as explained below. Also read the section FIRE AND EXPLOSION HAZARD on page 3. |

1. *Pump:* use a ground wire and clamp. See Fig. 1. Loosen the grounding lug locknut (W) and washer (X). Insert one end of the ground wire (Y) into the slot in lug (Z) and tighten the locknut securely. Connect the other end of the wire to a true earth ground. Order Part No. 237569 Ground Wire and Clamp (supplied with Model 205585).

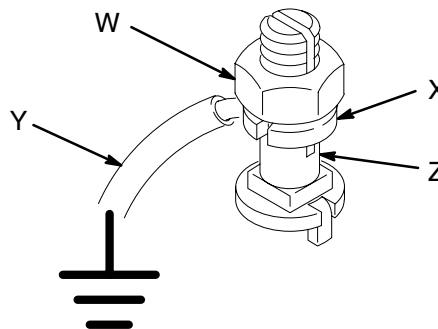

0864

Fig. 1

2. *Air and fluid hoses:* use only electrically conductive hoses.
3. *Air compressor:* follow manufacturer's recommendations.
4. *Spray gun:* ground through connection to properly grounded hoses and pump.
5. *Fluid supply container:* follow your local code.
6. *Object being sprayed:* follow your local code.
7. *Solvent pails used when flushing:* follow your local code. Use only metal pails, which are conductive, placed on a grounded surface. Do not place the pail on a nonconductive surface, such as paper or cardboard, which interrupts the grounding continuity.
8. *To maintain grounding continuity when flushing or relieving pressure,* hold a metal part of the spray gun firmly to the side of a grounded *metal* pail, then trigger the gun.

Setup

Available Accessories (must be purchased separately)

NOTE: Always use Genuine Graco Parts and Accessories, available from your Graco distributor. If you supply your own accessories, be sure they are adequately sized and pressure rated for your system.

Fig. 2 is only a guide for selecting and installing system components and accessories. Contact your Graco distributor for assistance in designing a system to suit your particular needs.

Air Line Accessories

WARNING

A red-handled bleed-type master air valve (E) is required in your system to help reduce the risk of serious injury, including splashing of fluid in the eyes or on the skin, and injury from moving parts if you are adjusting or repairing the pump.

The bleed-type master air valve relieves air trapped between this valve and the pump after the air is shut off. Trapped air can cause the pump to cycle unexpectedly. Locate the valve close to the pump.

- **The red-handled bleed-type master air valve (E)** is required in your system to relieve air trapped between it and the air motor when the valve is closed (see the **WARNING** above). Be sure the bleed valve is easily accessible from the pump, and is located **downstream** from the air filter/regulator (G). Order Part No. 113329 Bleed Valve (supplied with Model 205585).
- **The air filter/regulator (G)** controls pump speed and outlet pressure by adjusting the air pressure to the pump and the air spray gun. It also removes harmful dirt and moisture from the compressed air supply. Locate the pump air filter/regulator **upstream** from the bleed-type master air valve (E). Also, supply an air filter/regulator at each spray booth.

- **An air line lubricator (J)** provides automatic air motor lubrication. Install downstream from the pump air filter/regulator (G).
- **Install additional air bleed valves (M)** at each air line drop, to isolate accessories for servicing.

Fluid Line Accessories

WARNING

A fluid drain valve (K) is required in your system to help reduce the risk of serious injury, including splashing of fluid in the eyes or on the skin.

The fluid drain valve assists in relieving fluid pressure in the displacement pump, hose, and gun. Triggering the gun to relieve pressure may not be sufficient.

- **The fluid drain valve (K)** is required in your system to relieve fluid pressure in the hose and gun (see the **WARNING** above).
- **Install a fluid filter (H)** to remove impurities from the fluid before it reaches the spray gun (L).
- **Install a fluid pressure regulator (A)** to provide precise fluid pressure control at each spray booth.

Supplied Components

Refer to Fig. 3.

- **The pump air valve (4)** controls the pump speed by adjusting the supply of air to the pump.
- **The pump restrictor valve (12)** adjusts the fluid pressure by restricting the fluid flow.
- **The agitator (N) is supplied on Model 205585 only.** To prevent fluid from settling out, operate the agitator as explained in its separate manual 306565.

Setup

Connect the Hoses and Gun

NOTE: Be sure the hoses are properly sized and pressure-rated for your system. Use only electrically conductive hoses.

For One to Five Guns, Circulating System

1. Install a fluid pressure regulator (A) at each spray booth. See Fig. 2.
2. Install an air filter/regulator (G) and an air bleed valve (M) at each spray booth.
3. Connect an air supply hose (F) between the air filter/regulator (G) and the air inlet of the gun (L).
4. Connect a fluid return line (B) between the fluid regulator (A) and the return port of the pump.
5. Connect a fluid supply line (C) between the fluid outlet of the pump and the fluid regulator (A).
6. Connect a fluid hose (C) between the fluid regulator and the fluid inlet of the spray gun.
7. Connect an air supply hose to the air inlet of the pump (R). See Fig. 3.

KEY

| | | |
|--|---|--|
| A Fluid Pressure Regulator | G Air Filter/Regulator | N Agitator (supplied on Model 205585) |
| B Circulating Fluid Return Line | H Fluid Filter | P Pump |
| C Circulating Fluid Supply Line | J Air Line Lubricator | Y Ground Wire (required; see page 4 for installation instructions; supplied on Model 205585) |
| D Main Air Supply Line | K Fluid Drain Valve (required) | |
| E Red-Handled Bleed-Type Master Air Valve (required, for pump; supplied on Model 205585) | L Air Spray Gun | |
| F Electrically Conductive Air Supply Hose | M Bleed-Type Master Air Valve (for accessories) | |

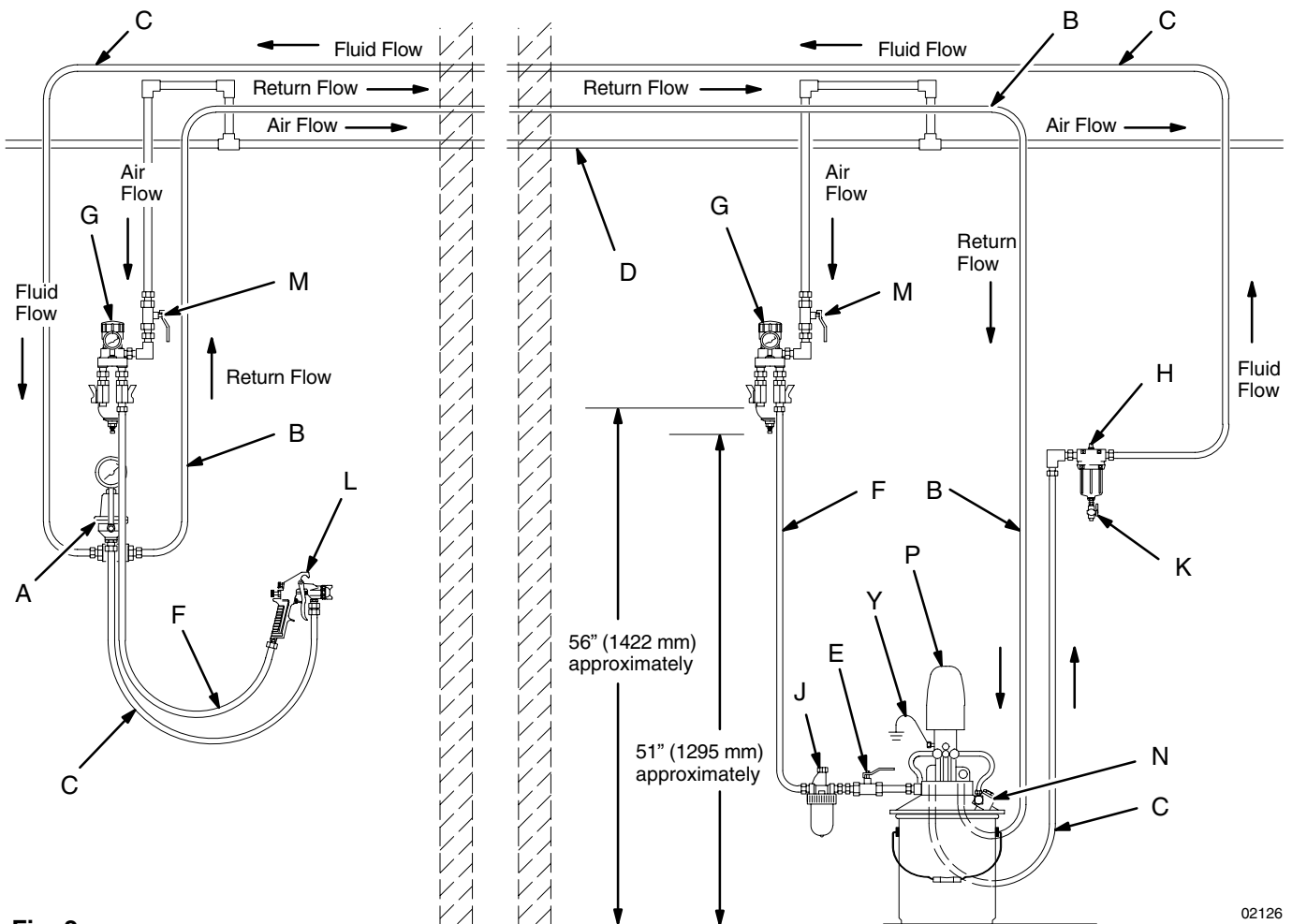

Fig. 2

02126

Setup

For a One Gun, Direct Supply System

1. Install a fluid pressure regulator (A) at the spray booth. See Fig. 2.
2. Install an air filter/regulator (G) and an air bleed valve (M) at the spray booth.
3. Connect an air supply hose (F) between the air filter/regulator (G) and the air inlet of the gun (L).
4. See Fig. 3. Connect a fluid supply line (C) between the pump fluid outlet nipple (59) and the fluid regulator (A).
5. Connect a fluid hose (C) between the fluid regulator and the fluid inlet of the spray gun.
6. Connect an air supply hose to the air inlet of the pump (R).

Model 205585 Shown

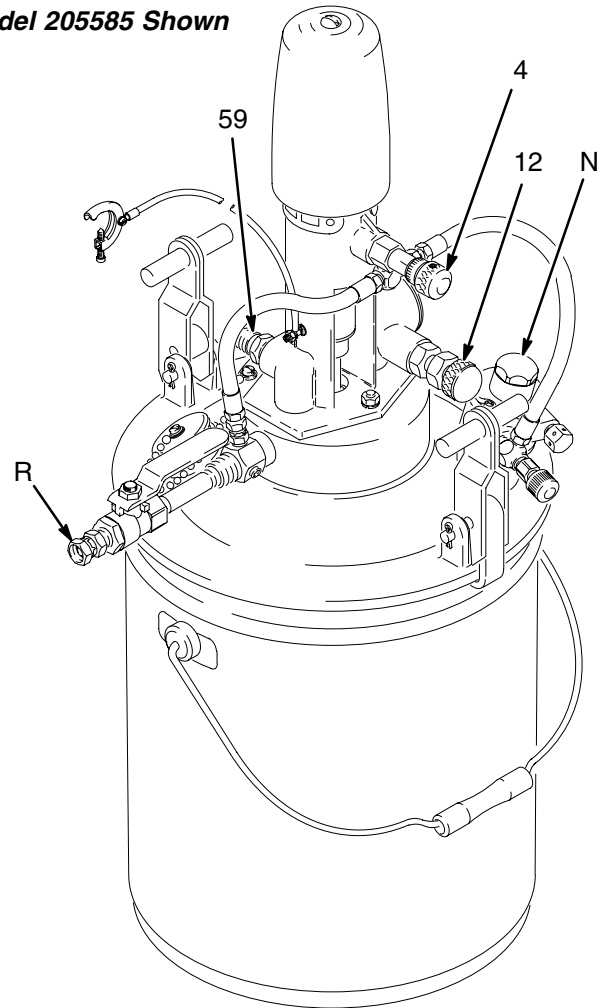

Fig. 3

02121

For a Two Gun, Direct Supply System

NOTE: Order Outlet Manifold 203171 for two gun, direct supply operation.

1. Remove the nipple (59) from the fluid outlet of the pump. See Fig. 3.
2. Install the manifold studs in the fluid outlet (S) and return (T) ports of the pump. Tighten the manifold setscrews (U) to secure. See Fig. 4.
3. Install a fluid pressure regulator (A) at each spray booth. See Fig. 2.
4. Connect two fluid hoses to the manifold outlets (V). Connect the other end of the hoses to the fluid regulators (A).
5. Connect a fluid hose (C) between the fluid regulator (A) and the fluid inlet of the spray gun (L).
6. Install an air filter/regulator (G) and an air bleed valve (M) at each spray booth.
7. Connect an air supply hose (F) between the air filter/regulator (G) and the air inlet of the gun (L).
8. Connect an air supply hose to the air inlet of the pump (R).

Model 205585 Shown

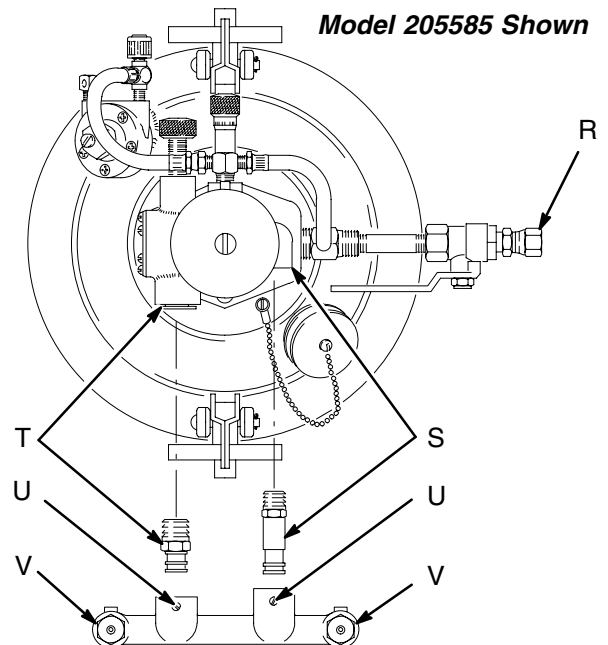

Fig. 4

02122

Operation

Pressure Relief Procedure

WARNING

PRESSURIZED EQUIPMENT HAZARD

The system pressure must be manually relieved to prevent the system from starting or spraying accidentally. To reduce the risk of an injury from accidental spray from the gun, splashing fluid, or moving parts, follow the **Pressure Relief Procedure** whenever you:

- are instructed to relieve the pressure,
- stop spraying,
- check or service any of the system equipment,
- or install or clean the spray nozzle.

1. Close the red-handled bleed-type master air valve (E, required in your system). Leave the pump air valve (4) open.
2. Close the pump restrictor valve (12).
3. Shut off the air to the agitator (if used).
4. Hold a metal part of the gun firmly to the side of a grounded metal pail, and trigger the gun to relieve pressure.
5. Open the drain valve (required in your system), having a container ready to catch the drainage.
6. Leave the drain valve open until you are ready to spray again.

If you suspect that the spray nozzle or hose is completely clogged, or that pressure has not been fully relieved after following the steps above, very slowly loosen the nozzle retaining ring or hose end coupling and relieve pressure gradually, then loosen completely. Now clear the nozzle or hose.

Packing Nut

WARNING

To reduce the risk of serious injury whenever you are instructed to relieve pressure, always follow the **Pressure Relief Procedure** at left.

Check the tightness of the packing nut (106) periodically. The nut should be tight enough to prevent leakage. Do not overtighten the packing nut. **Relieve pressure** before adjusting the nut.

Flush the Pump Before First Use

The pump is tested with lightweight oil, which is left in to protect the pump parts. If the fluid you are using may be contaminated by the oil, flush it out with a compatible solvent. See **Flushing** on page 12.

Lubrication

If you are not using an accessory air line lubricator, manually lubricate the motor daily. Disconnect the air line at the pump air inlet, place about 15 drops of light machine oil in the pump air inlet, reconnect the air line and turn on the air supply to blow air into the motor.

Using the Agitator

When starting the agitator, gradually increase the speed of the agitator by turning its needle valve (W) until a vortex begins to form in the fluid. Reduce the speed slightly. See Fig. 5.

For further agitator operating instructions, refer to the separate agitator manual 306565.

Operation

Prime the Pump (Direct Supply Systems)

1. See Figs. 2 and 5. Remove the spray nozzle from the gun. See the gun instruction manual.
2. Close all bleed-type air valves (E, M).
3. Close the pump air filter/regulator (G).
4. Close the fluid drain valve (K).
5. Check that all fittings throughout the system are tightened securely.
6. Connect the air supply line to the pump air inlet.
7. Open the bleed-type air valves (E, M). Open the air filter/regulator (G).
8. Hold a metal part of the gun firmly to the side of a grounded metal pail and hold the trigger open.
9. Slowly open the pump air valve (4) until the pump starts. Use the air valve to control pump speed and fluid pressure. Always use the lowest pressure necessary to get the desired results. Higher pressures cause premature nozzle and pump wear.
10. Cycle the pump slowly until all air is pushed out and the pump and hoses are fully primed.
11. Release the gun trigger and lock the trigger safety. The pump should stall against pressure.
12. With the pump and lines primed, and with adequate air pressure and volume supplied, the pump will start and stop as you open and close the gun.
13. **Relieve the pressure.** Install the spray nozzle in the gun, as explained in the gun manual.

WARNING

COMPONENT RUPTURE HAZARD



To reduce the risk of overpressurizing your system, which could cause component rupture and serious injury, *never exceed the specified Maximum Incoming Air Pressure to the pump* (see the **Technical Data**, on page 22).

WARNING

To reduce the risk of serious injury whenever you are instructed to relieve pressure, always follow the **Pressure Relief Procedure** on page 8.

CAUTION

Do not allow the pump to run dry. It will quickly accelerate to a high speed, causing damage. If your pump is running too fast, stop it immediately and check the fluid supply. If the container is empty and air has been pumped into the lines, refill the container and prime the pump and the lines, or flush and leave it filled with a compatible solvent. Eliminate all air from the fluid system.

Operation

Prime the Pump (Circulating Systems)

1. See Fig. 5. Remove the spray nozzle from the gun. See the gun instruction manual.
2. Close all bleed-type air valves (E, M).
3. Close the pump air filter/regulator (G).
4. Close the fluid drain valve (K).
5. Check that all fittings throughout the system are tightened securely.
6. Connect the air supply line to the pump air inlet.
7. Open the restrictor valve (12) by turning the knob clockwise as far as possible.
8. Open the bleed-type air valves (E, M). Open the air filter/regulator (G).
9. Hold a metal part of the gun firmly to the side of a grounded metal pail and hold the trigger open.

WARNING

COMPONENT RUPTURE HAZARD

 To reduce the risk of overpressurizing your system, which could cause component rupture and serious injury, *never exceed the specified Maximum Incoming Air Pressure to the pump* (see the **Technical Data**, on page 22).

10. Open the pump air valve (4) until the pump runs at about 50 cycles per minute. Adjust the pump air valve to maintain speed while closing the restrictor valve (12) to obtain the desired fluid pressure in the line. Always use the lowest pressure necessary to get the desired results. Higher pressures cause premature tip and pump wear.
11. When the pump speed and fluid pressure have been adjusted, tighten the restrictor valve locknut.
12. Release the gun trigger and lock the trigger safety. The pump will run continuously and speed up or slow down on demand, until the air is shut off.

WARNING

To reduce the risk of serious injury whenever you are instructed to relieve pressure, always follow the **Pressure Relief Procedure** on page 8.

13. **Relieve the pressure.** Install the spray nozzle in the gun, as explained in the gun manual.

CAUTION

Do not allow the pump to run dry. It will quickly accelerate to a high speed, causing damage. If your pump is running too fast, stop it immediately and check the fluid supply. If the container is empty and air has been pumped into the lines, refill the container and prime the pump and the lines, or flush and leave it filled with a compatible solvent. Eliminate all air from the fluid system.

Operation

Model 205585 Shown

KEY

- 4 Pump Air Valve
- 12 Pump Restrictor Valve
- E Red-Handled Bleed-Type Master Air Valve
- N Agitator
- W Agitator Needle Valve

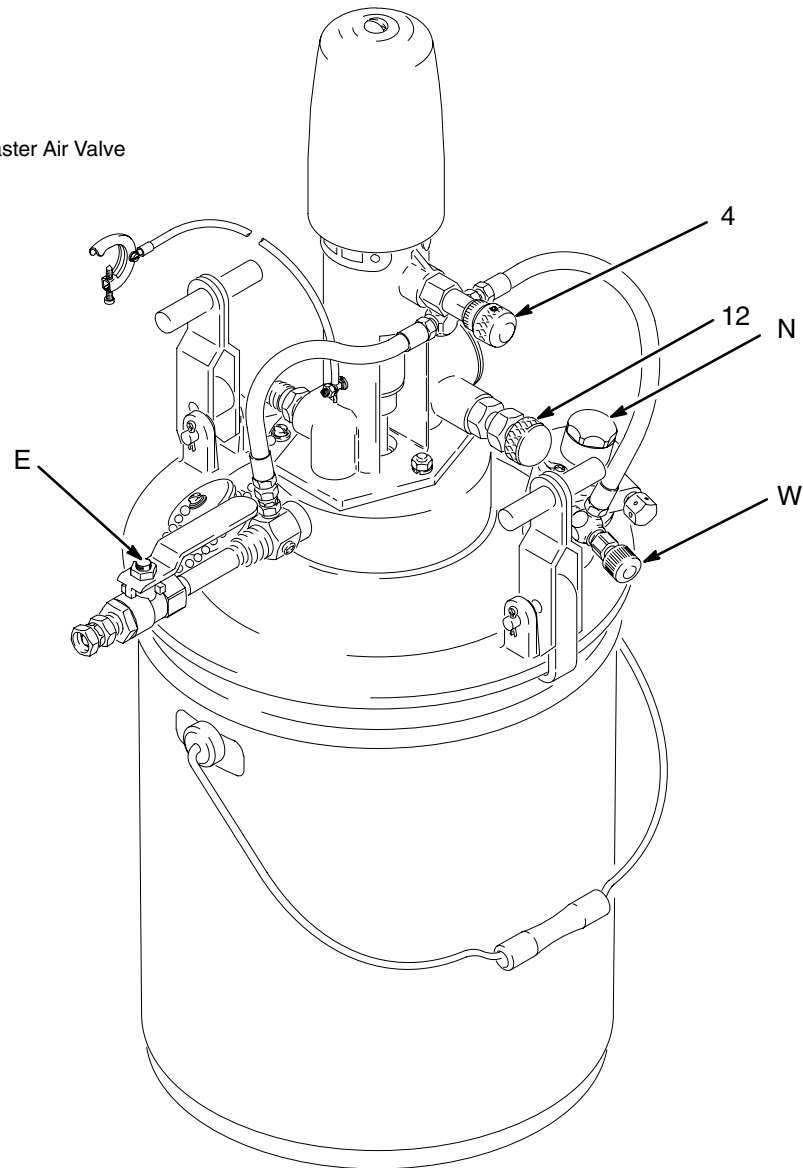

Fig. 5

02121

Operation

Shutdown and Care of the Pump

WARNING

To reduce the risk of serious injury whenever you are instructed to relieve pressure, always follow the **Pressure Relief Procedure** on page 8.

For overnight shutdown, stop the pump at the bottom of its stroke to prevent fluid from drying on the exposed displacement rod and damaging the throat packings. **Relieve the pressure.**

Always flush the pump before the fluid dries on the displacement rod. See **Flushing** below.

Flushing

WARNING



FIRE AND EXPLOSION HAZARD

Before flushing, read the section **FIRE AND EXPLOSION HAZARD** on page 3. Be sure the entire system and flushing pails are properly grounded. Refer to **Grounding** on page 4.



Flush the pump:

- Before the first use
- When changing colors or fluids
- Before fluid can dry or settle out in a dormant pump (check the pot life of catalyzed fluids)
- Before storing the pump.

Flush with a fluid that is compatible with the fluid you are pumping and with the wetted parts in your system. Check with your fluid manufacturer or supplier for recommended flushing fluids and flushing frequency.

CAUTION

Never leave water or water-base fluid in the pump overnight. If you are pumping water-base fluid, flush with water first, then with a rust inhibitor such as mineral spirits. Relieve the pressure, but leave the rust inhibitor in the pump to protect the parts from corrosion.

WARNING

To reduce the risk of serious injury whenever you are instructed to relieve pressure, always follow the **Pressure Relief Procedure** on page 8.

1. **Relieve the pressure.**
2. Remove the spray nozzle from the gun.
3. Hold a metal part of the gun firmly to the side of a grounded *metal* pail.
4. Start the pump. Always use the lowest possible fluid pressure when flushing.
5. Trigger the gun.
6. Flush the system until clear solvent flows from the gun.
7. **Relieve the pressure.**
8. Clean the spray nozzle separately, then reinstall it.

Troubleshooting

| Problem | Cause | Solution |
|-----------------------------|---|---|
| Low fluid output. | Fluid line, air line, or spray gun clogged. | Check and clear. |
| | Clogged fluid regulator or manifold. | Check and clear. |
| | Restricted main air supply. | Check. Open bleed-type master air valves. |
| | Empty fluid supply container. | Refill. |
| | Wrong restrictor valve setting. | Adjust; see page 10. |
| | Dried fluid on the displacement rod. | Clean the pump. Always stop the pump at the bottom of its stroke. |
| | Worn pump valves or packings. | Replace. See page 16. |
| Erratic agitator operation. | Low air supply. | Increase the air supply. |
| | The agitator motor is rusted or dirty. | See manual 306565 to service. |

NOTE: Check all possible causes and solutions before disassembling the unit.

Service

Before You Start

1. Have all the necessary repair parts on hand. Recommended spare parts are indicated in the parts list with a check mark, for example (18✓).
2. Repair Kit 207848 is available. Parts included in the kit are marked with an asterisk, for example (102*). Use all the parts in the kit for the best results.
3. Use a compatible solvent to clean parts. Inspect parts for wear or damage and replace as needed. Scoring or irregular surfaces on the displacement rod (111) or polished inner wall of the cylinder (110) cause premature packing wear and leaking. Check these parts by holding the parts up to a light at a slight angle.
4. Flush the system, if possible. See page 12.
5. Disconnect the hoses from the pump and remove it from its mounting. Clamp the pump in a vise.

Service

WARNING



To reduce the risk of injury from trapped air pressure when servicing the air motor, always remove air cap (11) from air cylinder (47) before removing air cylinder from base (68).

Air Motor

1. Remove the shield capscrew (28) and the shield (56).
2. Unscrew the air cap (11) from the air cylinder (47). To remove the spring (35), gently pry under the coils in the direction of the helix. Check the spring and gasket (60) and replace as necessary.
3. Unscrew the air cylinder (47) from the base.
4. Hold the air exhaust plate (18) with a pliers (P) and the flats of the air piston rod (10) with a wrench (N), and unscrew the piston and valve assembly (13). See Fig. 6. Remove the washer (37) and spring (36).
5. Disassemble and wash the parts thoroughly in a compatible, non-flammable solvent. Blow dry and inspect the parts for wear or damage.
6. If any valve plate spacers (15) are damaged, replace all three to maintain the correct clearance between the valve plates (17, 18) and the seats. See Fig. 7.
7. When reassembling, apply locking compound to the threads of the screws and torque to 10–14 in-lb (1.1–1.6 N•m). With the washer (37) in place, apply thread sealant to the threads of the piston. Carefully screw the piston (11) onto the shaft (23) by hand so it is securely fastened. **Do not use a pliers on the air exhaust plate while tightening.** When installed, there should be a 0.8 mm (0.032 in.) minimum clearance between the washer (37) and the piston shaft shoulder. See Fig. 6.

Restrictor Valve

1. Remove the stem (12) and o-ring (34) from the base. See Fig. 8.
2. Remove the seat (57) from the pump return port with a screwdriver.
3. Clean and inspect all parts for wear or damage and replace if necessary.

- 1  Do not use a pliers on the air exhaust plate while tightening.
- 2  Minimum 0.8 mm (0.032 in.) clearance between washer (37) and piston shaft shoulder.

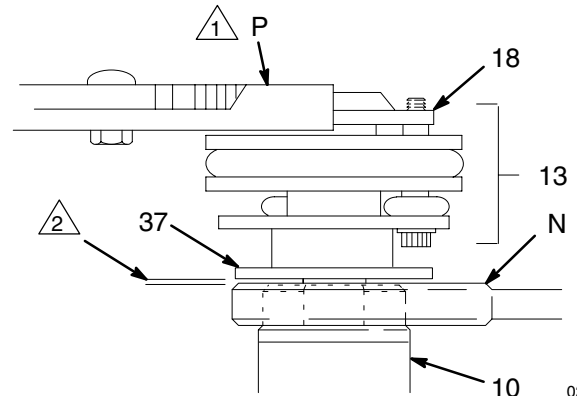



Fig. 6

02124

- 1  Apply locking compound to threads.
- 2  Torque to 10–14 in-lb (1.1–1.6 N•m).

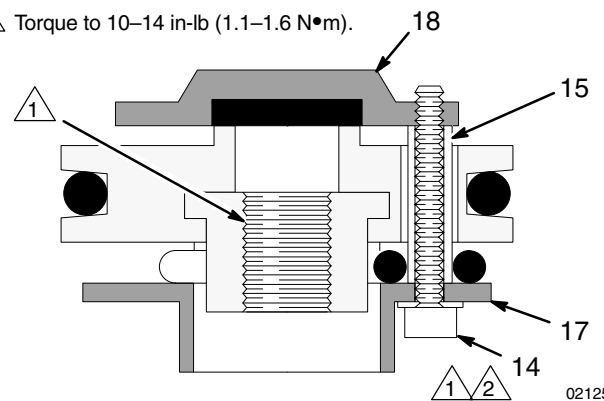

Fig. 7

02125

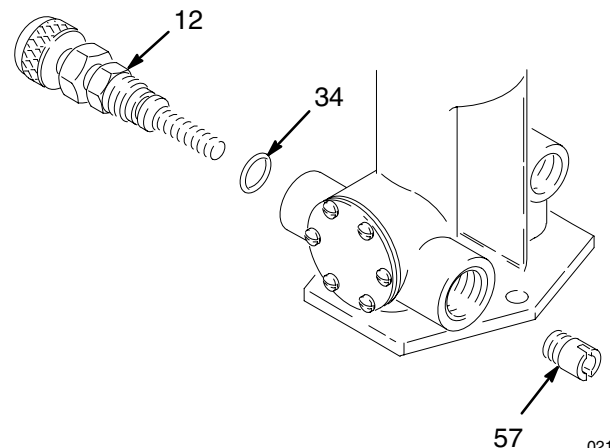

Fig. 8

02130

Service

Displacement Pump

Intake Valve

1. Unscrew the intake valve (109*) from the cylinder (110*) and disassemble. See Detail B of Fig. 9.
2. Clean and inspect all parts for wear or damage.
3. Reassemble the valve. To reseat the ball (102*), hold it against the seat with a brass rod and tap with a hammer. Unless further service is needed, apply thread sealant to the threads of the intake valve, screw it into the cylinder, and tighten securely.

Piston

1. Unscrew the cylinder (110*) from the outlet housing (112) and pull the cylinder down to expose the piston. Unscrew the piston stud (107) and remove the packings (103*), ball (101*), and washers (104, 105). See Detail B of Fig. 9.
2. Clean and inspect all parts for wear or damage and replace them if necessary.
3. To reseat the ball (101*), hold it against the seat with a brass rod and tap with a hammer. Reassemble in the reverse order of disassembly. Screw the stud (107) into the displacement rod (111) and torque to 20–30 ft-lb (27–41 N•m).

Throat Packings

1. To remove the displacement pump, remove the lower locknut (39) from the return tube (64). Disconnect the union (30) from the supply tube (62). Remove the cotter pin (27) to free the upper end of the connecting rod (63). Remove the cotter pin from the lower end of the connecting rod and unscrew the rod from the displacement rod (111). See Detail A of Fig. 9.
2. Unscrew the cylinder (110*) from the outlet housing (112). If the displacement rod (111) is seized by dried fluid, soak in a compatible solvent before disassembling; **do not** try to break loose by twisting the rod.
3. Unscrew the packing nut (106) and remove the bearing (113*), packing (114*), and o-ring (115*). Clean and inspect all parts for wear or damage and replace if necessary.
4. Make sure that all parts are completely free of paint fillers and pigments. Fill the displacement rod cavity with heavy grease and reassemble in the reverse order of disassembly.
5. When reconnecting the displacement pump to the air motor, first tighten the union (30) onto the supply tube (62), then screw the upper nut (39) on the return tube down to the outlet housing (112) and lock in place with the lower lockwasher (25) and nut (39).

Service

- △1 See Fig. 7.
- △2 See Detail A at left.
- △3 See Detail B at left.
- △4 Torque to 20–30 ft-lb (27–41 N•m).
- △5 Lips face up.
- △6 Lips face down.

Detail A: Pump Throat

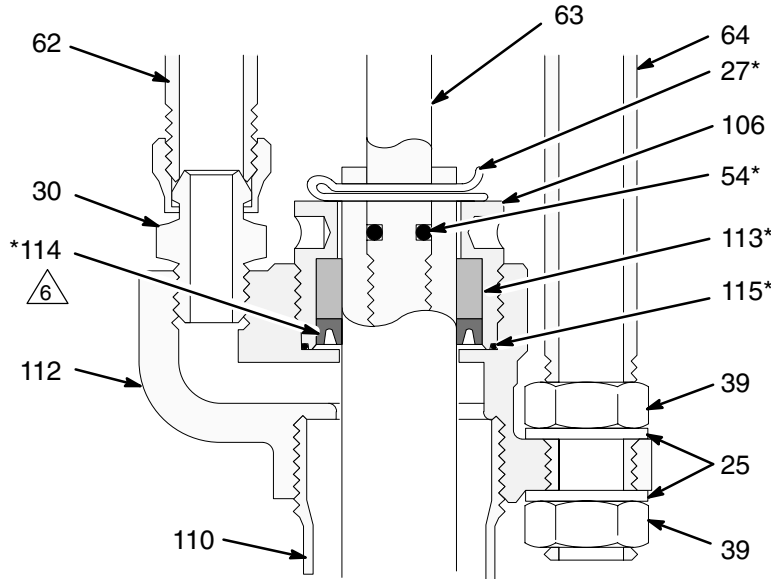

Detail B: Intake Valve and piston Valve

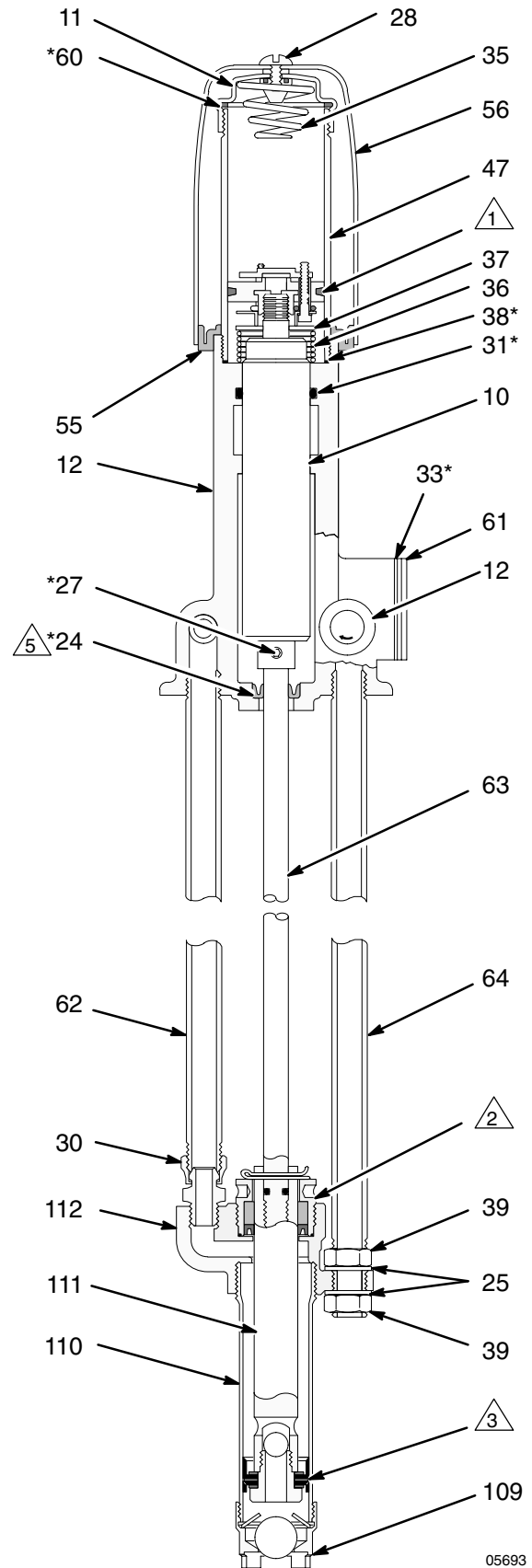
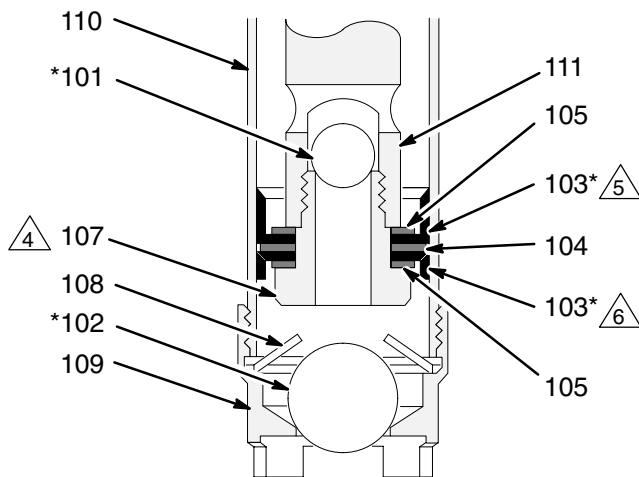

Fig. 9

05693

Parts

Part No. 205585, Series D (includes items 1–99)

| Ref. No. | Part No. | Description | Qty. |
|----------|----------|---|------|
| 1 | 204534 | HOOK, cover | 2 |
| 2 | 204535 | HANDLE, clamp | 2 |
| 3 | 205595 | 2:1 STANDARD PUMP, Series E; See page 21 | 1 |
| 67 | 206755 | CORD, wire; no. 8 screw size loops; 5–1/2" (138 mm) long | 1 |
| 68 | 207351 | BASE, pump mounting | 1 |
| 69 | 100016 | LOCKWASHER, spring; 1/4" | 2 |
| 70 | 100015 | NUT, hex; 1/4–20 thd size | 2 |
| 71 | 100063 | PIN, cotter; 1/16" (1.5 mm) diameter; 1/2" (13 mm) long | 2 |
| 74 | 100721 | PLUG, slotted hd pipe; 1/4 npt | 1 |
| 75 | 100933 | SCREW, self tap type "F"; no. 8–32; 3/8" (10 mm) long | 2 |
| 76 | 101108 | PAIL; 5 gallon (19 liter) | 1 |
| 78 | 101962 | SCREW, socket hd set; 1/4–20 x 3/8" (10 mm) long | 2 |
| 80 | 156593 | O-RING; nitrile rubber | 1 |
| 81 | 158223 | WASHER, flat | 2 |
| 82 | 164724 | HOSE, air; 1/4" (6 mm) ID; 1/8 npt(mbe); 10" (254 mm) long | 2 |
| 83 | 161395 | PIN, handle pivot | 2 |
| 85 | 164725 | COVER, pail | 1 |
| 86 | 164726 | PLUG, fill | 1 |
| 87 | 164815 | TEE, pipe; 1/8 npt (m x f x f) | 1 |
| 89 | 167709 | BOLT, hook | 2 |
| 90 | 224571 | AGITATOR, 5 gallon (19 liter); see 306565 for parts | 1 |
| 93 | 101690 | WRENCH, allen (not shown) | 1 |
| 96 | 100124 | NIPPLE; 1/4 npt | 1 |
| 97 | 113329 | BLEED VALVE, red-handled; 1/4 npt (fbe) | 1 |
| 98 | 156823 | UNION, swivel; 1/4 npt(m) x 1/4 npsm(f) | 1 |
| 99 | 237569 | GROUND WIRE AND CLAMP | 1 |

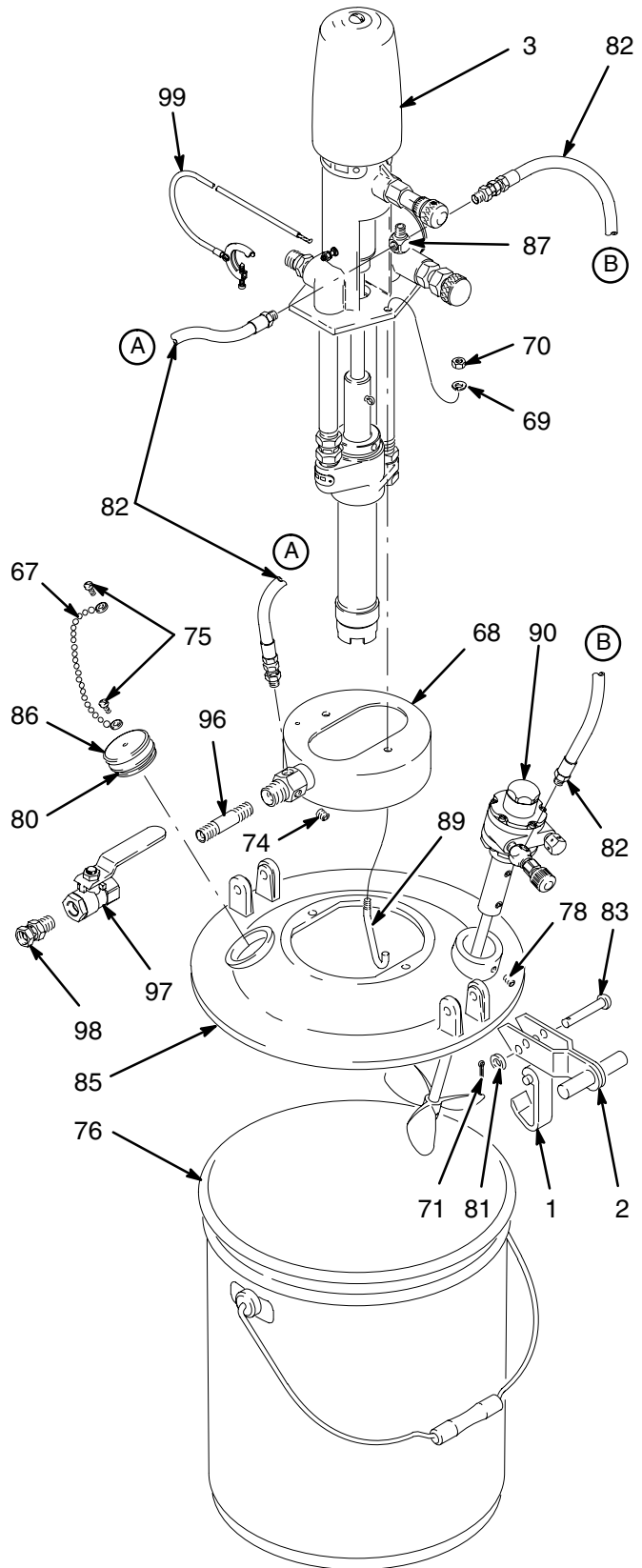

02123

Parts

Part No. 205584, Series A (includes items 1-89)

| Ref. No. | Part No. | Description | Qty. |
|----------|----------|---|------|
| 1 | 204534 | HOOK, cover | 2 |
| 2 | 204535 | HANDLE, clamp | 2 |
| 3 | 205595 | 2:1 STANDARD PUMP, Series E; See page 21 | 1 |
| 67 | 206755 | CORD, wire; no. 8 screw size loops; 5-1/2" (138 mm) long | 1 |
| 68 | 207351 | BASE, pump mounting | 1 |
| 69 | 100016 | LOCKWASHER, spring; 1/4" | 2 |
| 70 | 100015 | NUT, hex; 1/4-20 thd size | 2 |
| 71 | 100063 | PIN, cotter; 1/16" (1.5 mm) diameter; 1/2" (13 mm) long | 2 |
| 72 | 100403 | PLUG, pipe | 1 |
| 74 | 100721 | PLUG, slotted hd pipe; 1/4 npt | 1 |
| 75 | 100933 | SCREW, self tap type "f"; no. 8-32; 3/8" (10 mm) long | 2 |
| 76 | 101108 | PAIL; 5 gallon (19 liter) | 1 |
| 77 | 101342 | PLUG, button | 1 |
| 78 | 101962 | SCREW, socket hd set; 1/4-20 x 3/8" (10 mm) long | 2 |
| 80 | 156593 | O-RING; nitrile rubber | 1 |
| 81 | 158223 | WASHER, flat | 2 |
| 82 | 164724 | HOSE, air; 1/4" (6 mm) ID; 1/8 npt(mbe); 10" (254 mm) long | 2 |
| 83 | 161395 | PIN, handle pivot | 2 |
| 84 | 162453 | NIPPLE, pipe; 1/4 npt x 1/4 npsm | 1 |
| 85 | 164725 | COVER, pail | 1 |
| 86 | 164726 | PLUG, fill | 1 |
| 87 | 164815 | TEE, pipe; 1/8 npt (m x f x f) | 1 |
| 89 | 167709 | BOLT, hook | 2 |

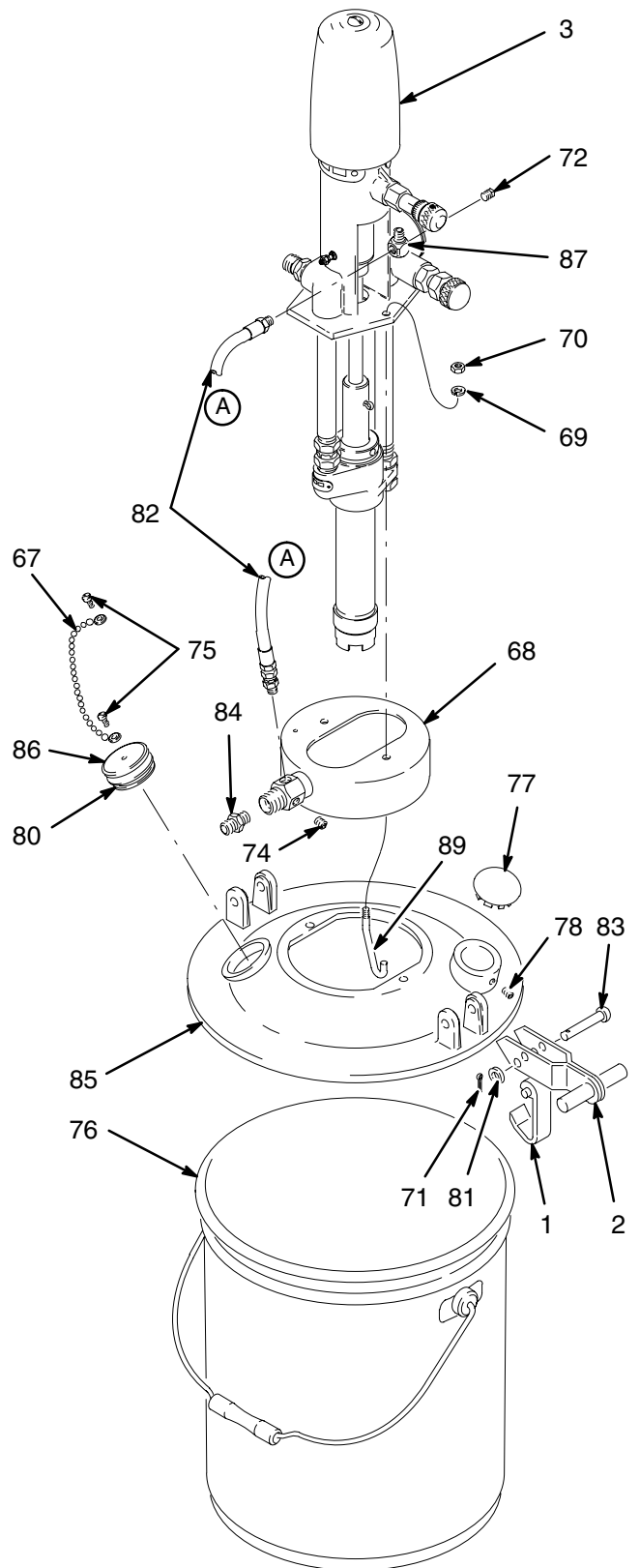

Parts

Part No. 205595 Standard Pump, Series E (includes items 495)

Part No. 203367 Displacement Pump, Series B (includes items 101–115)

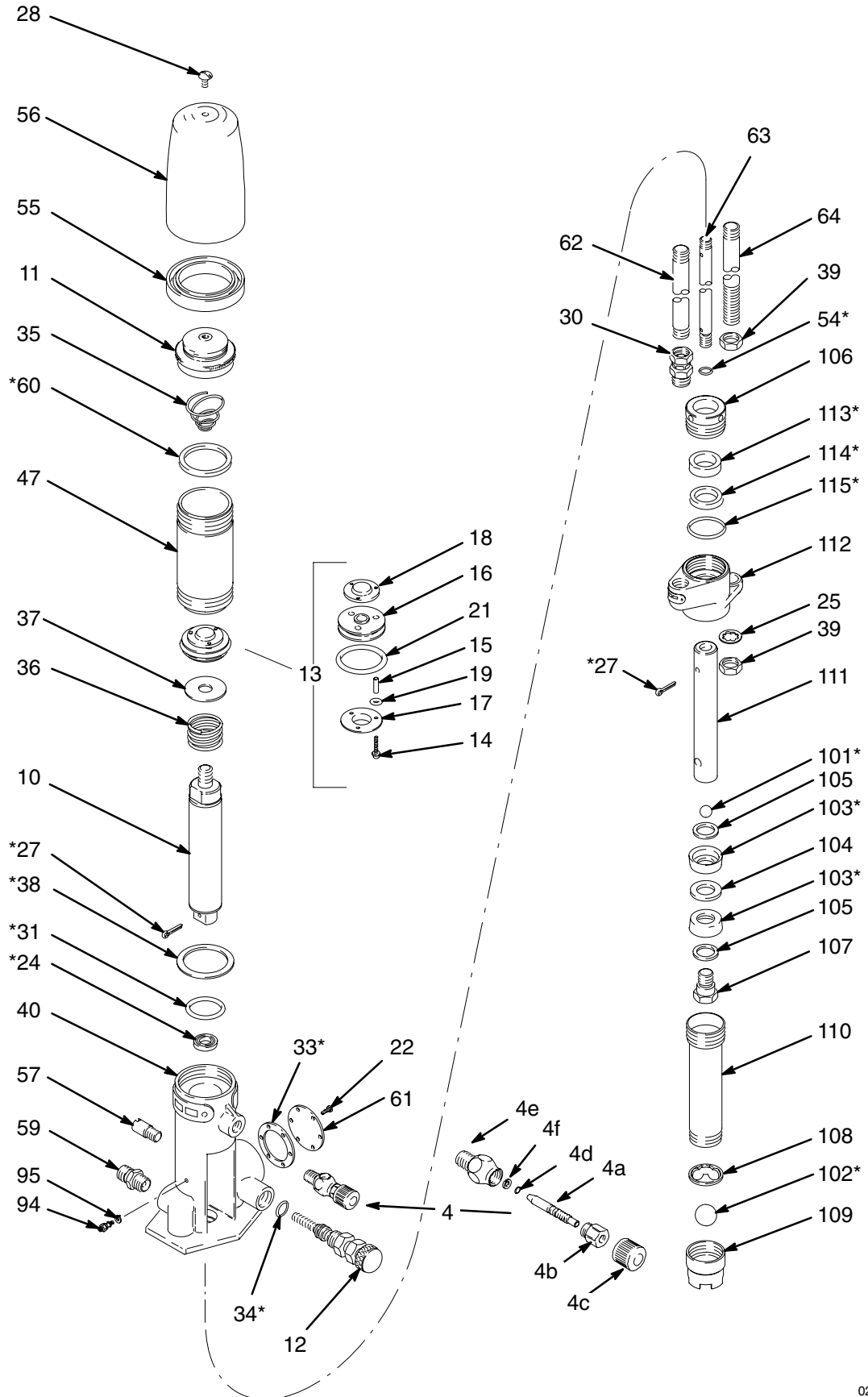

Parts

Part No. 205595 Standard Pump, Series E (includes items 4–95)

| Ref. No. | Part No. | Description | Qty. | Ref. No. | Part No. | Description | Qty. |
|----------|----------|---|------|---|-----------------|--|-------------|
| 4 | 206264 | AIR VALVE Includes items 4a–f | 1 | 56 | 161255 | SHIELD, air motor | 1 |
| 4a | 166529 | .VALVE, needle | 1 | 57 | 161306 | SEAT, valve | 1 |
| 4b | 166532 | .NUT, packing | 1 | 59 | 162485 | NIPPLE, pipe; 3/8 npt x 3/8 npsm | 1 |
| 4c | 164698 | .KNOB, adjusting | 1 | 60* | 162989 | GASKET; neoprene | 1 |
| 4d | 157628 | .O-RING, packing | 1 | 61 | 164806 | PLATE, cover, pressure gauge mounting | 1 |
| 4e | 165722 | .BODY, valve | 1 | 62 | 164807 | TUBE, supply; 6–5/8" (166 mm) long | 1 |
| 4f | 166531 | .WASHER | 1 | 63 | 181257 | ROD, connecting; 8–1/2" (213 mm) long | 1 |
| 10 | 219091 | ROD, piston | 1 | 64 | 164809 | TUBE, return; 9–3/4" (245 mm) long | 1 |
| 11 | 204465 | CAP, air motor cylinder | 1 | 94 | 104029 | GROUNDING LUG | 1 |
| 12✓ | 204496 | VALVE, restrictor | 1 | 95 | 104582 | WASHER, tab | 1 |
| 13 | 220168 | AIR PISTON AND VALVE; Includes items 14–19, 21 | 1 | * These parts are included in Repair Kit 207848, which may be purchased separately. | | | |
| 14 | 220884 | . SCREW, socket hd cap; no. 6–32 x 1" (25 mm); with copper gasket | 3 | | | | |
| 15 | 181485 | . SPACER, valve plate | 3 | ✓ Recommended spare parts. Keep on hand to reduce downtime. | | | |
| 16 | 189210 | . PISTON, air motor | 1 | | | | |
| 17 | 181487 | . PLATE, intake valve | 1 | | | | |
| 18✓ | 162729 | . PLATE, exhaust valve | 1 | | | | |
| 19✓ | 108358 | . O-RING; fluoroelastomer | 3 | | | | |
| 20 | 203367 | DISPLACEMENT PUMP, Series B; See separate parts list at right | 1 | Ref. No. 20 Displacement Pump 203367, Series B (includes items 101–115) | | | |
| 21✓ | 108357 | O-RING; fluoroelastomer | 1 | Ref. No. | Part No. | Description | Qty. |
| 22 | 100258 | SCREW, fillister hd machine; no. 8–32 x 3/8" (10 mm) | 6 | 101* | 100084 | BALL, piston; 1/2" (13 mm) diameter | 1 |
| 24* | 101389 | SEAL | 1 | 102* | 100279 | BALL, intake; 7/8" (22 mm) diameter | 1 |
| 25 | 101390 | LOCKWASHER, internal shakeproof; 3/8" size | 2 | 103* | 156811 | PACKING, cup; leather | 2 |
| 27* | 108450 | PIN, cotter; 1/8" (3 mm) diameter; 1" (25 mm) long | 2 | 104 | 158886 | WASHER | 1 |
| 28 | 101870 | SCREW, oval hd machine; 1/4–20 x 3/8" (10 mm) | 1 | 105 | 158887 | WASHER, backup | 2 |
| 30 | 155665 | UNION, straight swivel; 3/8 npt (m x f) | 1 | 106 | 181251 | NUT, packing | 1 |
| 31* | 156698 | O-RING; nitrile rubber | 1 | 107 | 158891 | STUD, piston | 1 |
| 33* | 157127 | GASKET, flat; vellumoid | 1 | 108 | 159100 | STOP, ball | 1 |
| 34* | 157250 | O-RING; nitrile rubber | 1 | 109 | 159101 | HOUSING, intake valve | 1 |
| 35✓ | 157630 | SPRING, tapered compression | 1 | 110 | 159469 | CYLINDER | 1 |
| 36✓ | 157633 | SPRING, helical compression | 1 | 111 | 159470 | ROD, displacement | 1 |
| 37 | 157872 | WASHER | 1 | 112 | 181254 | HOUSING, outlet | 1 |
| 38* | 158109 | GASKET; nitrile rubber | 1 | 113* | 181255 | BEARING, rod | 1 |
| 39 | 158874 | NUT, hex; 11/16–18 | 2 | 114* | 108285 | PACKING, u-cup; UHMWPE | 1 |
| 40 | 158879 | BASE, air motor | 1 | 115* | 107078 | O-RING; PTFE | 1 |
| 47 | 158896 | CYLINDER, air motor | 1 | * These parts are included in Repair Kit 207848, which may be purchased separately. | | | |
| 54* | 111316 | O-RING | 1 | | | | |
| 55 | 161253 | RING, support | 1 | | | | |

Technical Data

| Category | Data |
|---|--------------------------------------|
| Maximum fluid working pressure | 360 psi (25 bar) |
| Maximum air input pressure | 180 psi (12 bar) |
| Ratio | 2:1 |
| Pump cycles per gallon (3.8 liters) | 46 |
| Fluid flow at 60 cycles per minute | 1.25 gallons (4.7 liters) |
| Air inlet size | 1/4 npsm(f) |
| Fluid outlet size | 3/8 npsm(m) |
| Fluid inlet size | 2 in. npt(f) |
| Maximum operating temperature | 180°F (82°C) |
| * Sound level at 180 psi, 25 cycles/min | 75 dBa |
| * Sound power level at 180 psi, 25 cycles/min | 80 dBa |
| Wetted parts | Pump: Steel, aluminum, iron, leather |

* Tested in accordance with ISO 3744.

KEY: Fluid Outlet Pressure – Black Curves
Air Consumption – Gray Curves

A 180 psi (12.5 bar) Air Pressure
B 100 psi (7 bar) Air Pressure
C 70 psi (4.9 bar) Air Pressure
D 40 psi (2.8 bar) Air Pressure

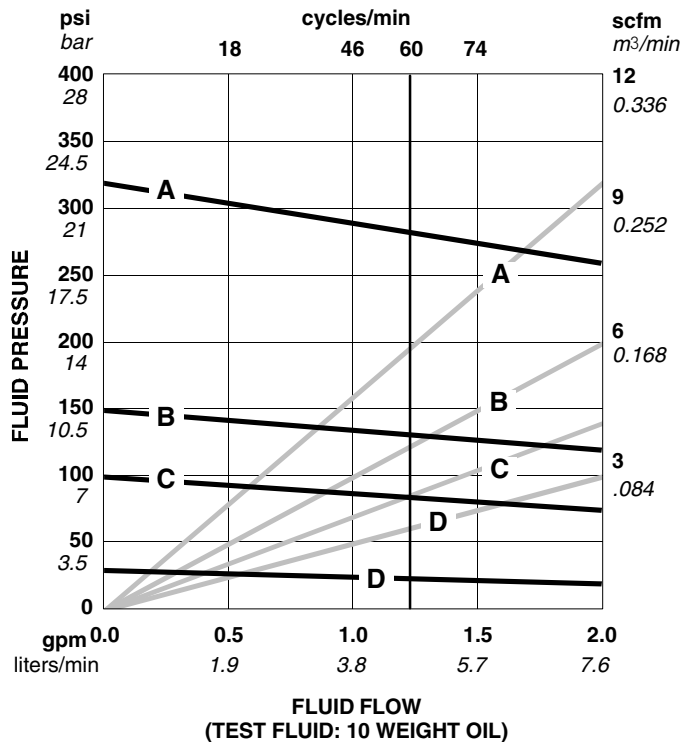

To find Fluid Outlet Pressure (bar/psi) at a specific fluid flow (lpm/gpm) and operating air pressure (bar/psi):

1. Locate desired flow along bottom of chart.
2. Follow vertical line up to intersection with selected fluid outlet pressure curve (black). Follow left to scale to read fluid outlet pressure.

To find Pump Air Consumption (m³/min or scfm) at a specific fluid flow (lpm/gpm) and air pressure (bar/psi):

1. Locate desired flow along bottom of chart.
2. Read vertical line up to intersection with selected air consumption curve (gray). Follow right to scale to read air consumption.

Dimensions

Model 205585 Shown

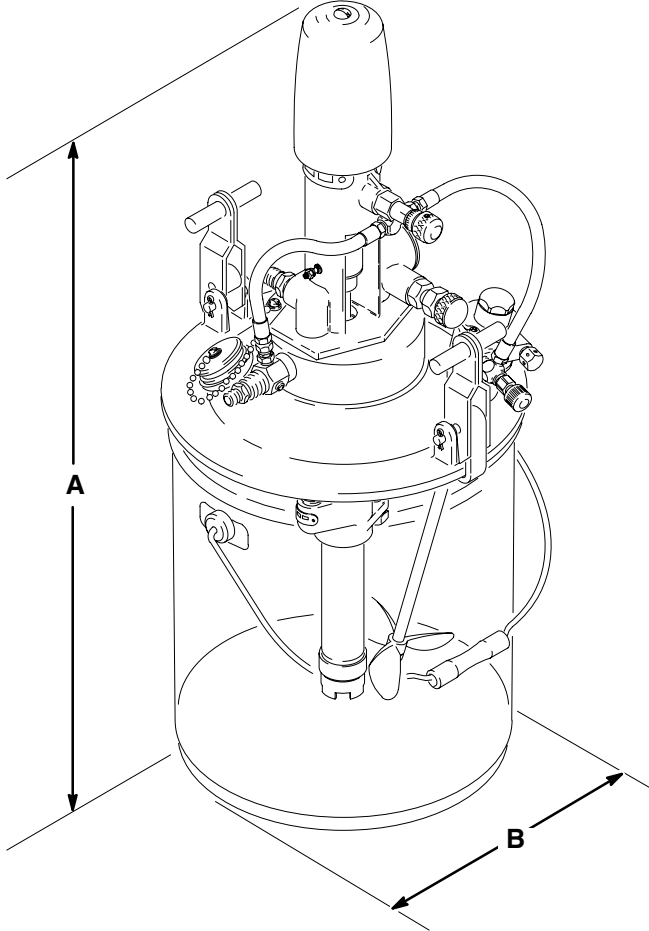

02120

| Pump Model | A | B | Weight |
|------------|-----------------|-----------------|-----------------|
| 205585 | 29 in. (737 mm) | 13 in. (330 mm) | 12.7 kg (28 lb) |
| 205584 | 29 in. (737 mm) | 13 in. (330 mm) | 11.8 kg (26 lb) |

Graco Standard Warranty

WARRANTY

Graco warrants all equipment listed in this manual which is manufactured by Graco and bearing its name to be free from defects in material and workmanship on the date of sale to the original purchaser for use. Graco will, for a period of twelve months from the date of sale, repair or replace any part of the equipment determined by Graco to be defective. This warranty applies only when the equipment is installed, operated and maintained in accordance with Graco's written recommendations.

This warranty does not cover, and Graco shall not be liable for general wear and tear, or any malfunction, damage or wear caused by faulty installation, misapplication, abrasion, corrosion, inadequate or improper maintenance, negligence, accident, tampering, or substitution of non-Graco component parts. Nor shall Graco be liable for malfunction, damage or wear caused by the incompatibility of Graco equipment with structures, accessories, equipment or materials not supplied by Graco, or the improper design, manufacture, installation, operation or maintenance of structures, accessories, equipment or materials not supplied by Graco.

This warranty is conditioned upon the prepaid return of the equipment claimed to be defective to an authorized Graco distributor for verification of the claimed defect. If the claimed defect is verified, Graco will repair or replace free of charge any defective parts. The equipment will be returned to the original purchaser transportation prepaid. If inspection of the equipment does not disclose any defect in material or workmanship, repairs will be made at a reasonable charge, which charges may include the costs of parts, labor, and transportation.

THIS WARRANTY IS EXCLUSIVE, AND IS IN LIEU OF ANY OTHER WARRANTIES, EXPRESS OR IMPLIED, INCLUDING BUT NOT LIMITED TO WARRANTY OF MERCHANTABILITY OR WARRANTY OF FITNESS FOR A PARTICULAR PURPOSE.

Graco's sole obligation and buyer's sole remedy for any breach of warranty shall be as set forth above. The buyer agrees that no other remedy (including, but not limited to, incidental or consequential damages for lost profits, lost sales, injury to person or property, or any other incidental or consequential loss) shall be available. Any action for breach of warranty must be brought within two (2) years of the date of sale.

GRACO MAKES NO WARRANTY, AND DISCLAIMS ALL IMPLIED WARRANTIES OF MERCHANTABILITY AND FITNESS FOR A PARTICULAR PURPOSE IN CONNECTION WITH ACCESSORIES, EQUIPMENT, MATERIALS, OR COMPONENTS SOLD BUT NOT MANUFACTURED BY GRACO. These items sold, but not manufactured by Graco (such as electric motors, switches, hose, etc.) are subject to the warranty, if any, of their manufacturer. Graco will provide purchaser with reasonable assistance in making any claim for breach of these warranties.

For Sales to Canadian Customers:

Except as expressly stated herein, Graco makes no representations, warranties or conditions, express, implied or collateral, concerning any goods or services sold, and **GRACO SHALL NOT BE LIABLE IN ANY MANNER FOR** any other representation, warranty or condition of any kind, whether arising by operation of law or otherwise, including but not limited to, **WARRANTIES OF MERCHANTABILITY OR FITNESS FOR A PARTICULAR PURPOSE.**

LIMITATION OF LIABILITY

In no event will Graco be liable for indirect, incidental, special or consequential damages resulting from Graco supplying equipment hereunder, or for the furnishing, performance, or use of any products or other goods sold hereto, whether due to a breach of contract, breach of warranty, the negligence of Graco, or otherwise.

Graco Information

TO PLACE AN ORDER, contact your Graco distributor, or call one of the following numbers to identify the distributor closest to you:

1-800-328-0211 Toll Free
612-623-6921
612-378-3505 Fax

All written and visual data contained in this document reflects the latest product information available at the time of publication. Graco reserves the right to make changes at any time without notice.

This manual contains English. MM 306713

Graco Headquarters: Minneapolis
International Offices: Belgium, China, Japan, Korea
GRACO INC. P.O. BOX 1441 MINNEAPOLIS, MN 55440-1441

Copyright 1961, Graco Inc. is registered to ISO 9001

www.graco.com

Revised 03/2009