

Instructions–Parts List



STAINLESS STEEL

Dura–Flo™ 2400 Pumps

308152ZAA

Severe–Duty rod and cylinder, for abrasive coatings.



Important Safety Instructions

Read all warnings and instructions in this manual.
Save these instructions.

See page 2 for **Model Numbers, Maximum Working Pressures** and **Table of Contents**.

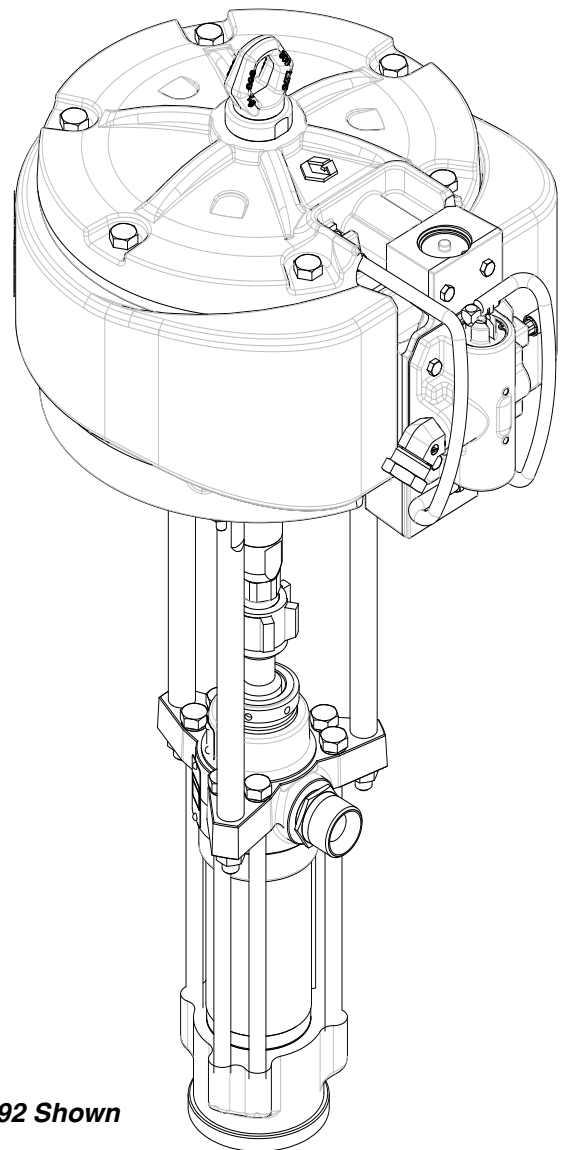

Part No. 24Y192 Shown



PROVEN QUALITY. LEADING TECHNOLOGY.

List of Models

Pump Part No. and Series	Pump Model	Displacement Pump Part No. and Series*	Ratio	Maximum Fluid Working Pressure	Maximum Air/Hydraulic Input Pressure
222827, Series A	Bulldog®	222803, Series A	10:1	7.0 MPa, 69 bar (1000 psi)	0.7 MPa, 7 bar (100 psi)
222899, Series A	King™	222803, Series A	20:1	13.8 MPa, 138 bar (2000 psi)	0.7 MPa, 7 bar (100 psi)
222898, Series B	Quiet King™	222803, Series A	20:1	13.8 MPa, 138 bar (2000 psi)	0.7 MPa, 7 bar (100 psi)
222900, Series B	Viscount®	222803, Series A	1.33:1	14.0 MPa, 138 bar (2000 psi)	10.0 MPa, 103 bar (1500 psi)
**24Y192, Series A	XL10000™	249991, Series A	34:1	23.0 MPa, 234 bar (3400 psi)	0.7 MPa, 7 bar (100 psi)
**24Y206, Series A	XL10000™	249991, Series A	34:1	23.0 MPa, 234 bar (3400 psi)	0.7 MPa, 7 bar (100 psi)

* This manual also covers displacement pumps 236226, 222994, 236230, and 222993. See pages 34 and 35.

** Not CE, EX

Table of Contents

Warnings	3	Parts Drawings and Parts Lists	26
Installation	8	Pump Assemblies	26
Air-Powered Pumps	8	Displacement Pumps	30
Hydraulic-Powered Pumps	10	Technical Data	36
Operation/Maintenance	13	Dimensions	43
All Pumps	13	Mounting Hole Layouts	44
Air-Powered Pumps	14	Graco Standard Warranty	46
Hydraulic-Powered Pumps	16	Graco Information	46
Troubleshooting Chart	18		
Service	19		
Required Tools	19		
Disconnecting the Displacement Pump	19		
Reconnecting the Displacement Pump	20		
Displacement Pump Service	22		

Symbols

Warning Symbol



This symbol alerts you to the possibility of serious injury or death if you do not follow the instructions.

Caution Symbol



This symbol alerts you to the possibility of damage to or destruction of equipment if you do not follow the instructions.

WARNING



INSTRUCTIONS

EQUIPMENT MISUSE HAZARD

Equipment misuse can cause the equipment to rupture or malfunction and result in serious injury.

- This equipment is for professional use only.
- Read all instruction manuals, tags, and labels before operating the equipment.
- Use the equipment only for its intended purpose. If you are uncertain about usage, call your Graco distributor.
- Do not alter or modify this equipment. Use only genuine Graco parts and accessories.
- Check equipment daily. Repair or replace worn or damaged parts immediately.
- Do not exceed the maximum working pressure of the lowest rated system component. Refer to the **Technical Data** section on page 36 for the maximum working pressure of this equipment.
- Use fluids and solvents which are compatible with the equipment wetted parts. Refer to the **Technical Data** section of all equipment manuals. Read the fluid and solvent manufacturer's warnings.
- Do not kink or overbend hoses or use hoses to pull equipment.
- Route hoses away from traffic areas, sharp edges, moving parts, and hot surfaces. Do not expose Graco hoses to temperatures above 82 °C (180 °F) or below -40 °C (-40 °F).
- Wear hearing protection when operating this equipment.
- Do not lift pressurized equipment.
- Comply with all applicable local, state, and national fire, electrical, and safety regulations.

WARNING



SKIN INJECTION HAZARD

Spray from the gun, hose leaks, or ruptured components can inject fluid into your body and cause extremely serious injury, including the need for amputation. Fluid splashed in the eyes or on the skin can also cause serious injury.



- Fluid injected into the skin might look like just a cut, but it is a serious injury. **Get immediate surgical treatment.**
- Do not point the gun at anyone or at any part of the body.
- Do not put your hand or fingers over the spray tip.
- Do not stop or deflect leaks with your hand, body, glove, or rag.
- Do not “blow back” fluid; this is not an air spray system.
- Always have the tip guard and the trigger guard on the gun when spraying.
- Check the gun diffuser operation weekly. Refer to the gun manual.
- Be sure the gun trigger safety operates before spraying.
- Lock the gun trigger safety when you stop spraying.
- Follow the **Pressure Relief Procedure** on page 13 whenever you: are instructed to relieve pressure; stop spraying; clean, check, or service the equipment; and install or clean the spray tip.
- Tighten all fluid connections before operating the equipment.
- Check the hoses, tubes, and couplings daily. Replace worn, damaged, or loose parts immediately. Permanently coupled hoses cannot be repaired; replace the entire hose.
- Use only Graco approved hoses. Do not remove any spring guard that is used to help protect the hose from rupture caused by kinks or bends near the couplings.



MOVING PARTS HAZARD

Moving parts, such as the air motor piston, can pinch or amputate your fingers.

- Keep clear of all moving parts when starting or operating the pump.
- Before servicing the equipment, follow the **Pressure Relief Procedure** on page 13 to prevent the equipment from starting unexpectedly.

WARNING



FIRE AND EXPLOSION HAZARD

Improper grounding, poor ventilation, open flames or sparks can cause a hazardous condition and result in a fire or explosion and serious injury.

- Ground the equipment and the object being sprayed. Refer to **Grounding** on page 7.
- If there is any static sparking or you feel an electric shock while using this equipment, **stop spraying immediately**. Do not use the equipment until you identify and correct the problem.
- Provide fresh air ventilation to avoid the buildup of flammable fumes from solvents or the fluid being sprayed.
- Eliminate all ignition sources such as pilot lights, cigarettes, and plastic drop cloths (static arc hazard). Do not plug or unplug power cords or turn lights on or off in the spray area.
- Keep the spray area free of debris, including solvent, rags, and gasoline.
- Electrically disconnect all equipment in the spray area.
- Extinguish all open flames or pilot lights in the spray area.
- Do not smoke in the spray area.
- Do not turn on or off any light switch in the spray area while operating or if fumes are present.
- Do not operate a gasoline engine in the spray area.
- Keep a fire extinguisher in the working area.



TOXIC FLUID HAZARD

Hazardous fluid or toxic fumes can cause serious injury or death if splashed in the eyes or on the skin, inhaled, or swallowed.

- Know the specific hazards of the fluid you are using.
- Store hazardous fluid in an approved container. Dispose of hazardous fluid according to all local, state, and national guidelines.
- Always wear protective eyewear, gloves, clothing, and respirator as recommended by the fluid and solvent manufacturer.

Installation

(ALL PUMPS)

Grounding

WARNING



FIRE AND EXPLOSION HAZARD

Before operating the pump, ground the system as explained below. Also read the section **FIRE AND EXPLOSION HAZARD** on page 5.

1. *King Pumps:* use a ground wire and clamp. See Fig. 1. Remove the ground screw (Z) and insert through eye of ring terminal at the end of ground wire (Y). Fasten ground screw back onto pump and tighten securely. Connect the other end of the wire to a true earth ground. Order Part No. 222011 Ground Wire and Clamp.

XL10000™ Pumps: See figure 3. Verify that the ground screw (GS) is attached and tightened securely to the air motor. connect the clamp (U) of the static ground cable (H) to a true earth ground. For a ground wire and clamp, order part No. 244524.

All Other Pumps: use a ground wire and clamp. See Fig. 2. Loosen the grounding lug locknut (W) and washer (X). Insert one end of a 1.5 mm² (12 ga) minimum ground wire (Y) into the slot in lug (Z) and tighten the locknut securely. Connect the other end of the wire to a true earth ground. Order Part No. 237569 Ground Wire and Clamp.

2. *Air, fluid, and hydraulic hoses:* Use only electrically conductive hoses with a maximum of 500 feet (150m) combined hose length to ensure grounding continuity. Check the electrical resistance of your hoses at least once a week. If the total resistance to ground exceeds 29 megohms, replace the hose immediately.

NOTE: Use a meter that is capable of measuring resistance at this level.

3. *Air compressor or hydraulic power supply:* follow manufacturer's recommendations.
4. *Spray gun:* ground through connection to a properly grounded fluid hose and pump.
5. *Fluid supply container:* follow your local code.
6. *Object being sprayed:* follow your local code.
7. *Solvent pails used when flushing:* follow your local code. Use only metal pails, which are conductive, placed on a grounded surface. Do not place the pail on a nonconductive surface, such as paper or cardboard, which interrupts the grounding continuity.

8. *To maintain grounding continuity when flushing or relieving pressure,* hold a metal part of the spray gun firmly to the side of a grounded *metal* pail, then trigger the gun.

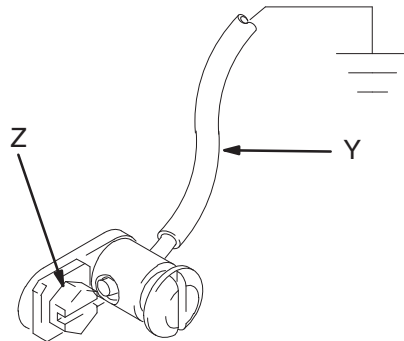

T11052

Fig. 1

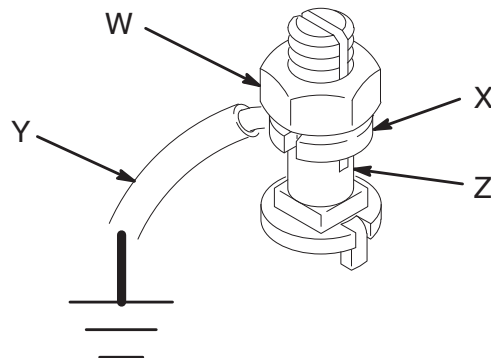

0864

Fig. 2

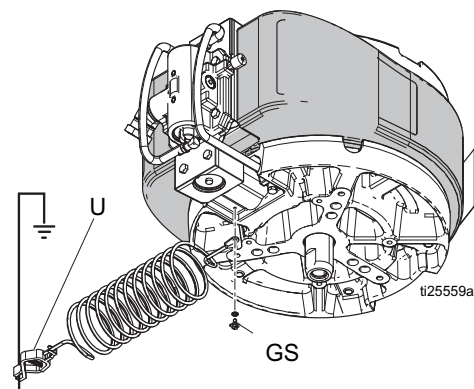

Fig. 3

Optional Fluid Outlet Fitting

Part No. 184470 Fluid Outlet Fitting is available for applications requiring a smaller fluid outlet fitting than the standard 1-1/2 in. npt(m). The 184470 Fitting is 3/4 npt(m) x M42 x 2.0. Contact your Graco distributor to order.

Notes

Installation

(AIR-POWERED PUMPS)

NOTE: Reference numbers and letters in parentheses in the text refer to the callouts in the figures and the Parts Drawing.

NOTE: Always use Graco Parts and Accessories, available from your Graco distributor. If you supply your own accessories, be sure they are adequately sized and pressure rated for your system.

Fig. 4 is only a guide for selecting and installing system components and accessories. Contact your Graco distributor for assistance in designing a system to suit your particular needs.

TYPICAL INSTALLATION

KEY

- | | | |
|--|---|--|
| A Pump | H Electrically Conductive Air Supply Hose | P Fluid Whip Hose |
| B Wall Bracket | J Air Line Filter | R Gun/Valve Swivel |
| C Pump Runaway Valve
Air Line | K Bleed-Type Master Air Valve
(for accessories) | S Airless Spray Gun or
Dispensing Valve |
| D Lubricator | L Fluid Filter | T Drum Suction Kit |
| E Bleed-Type Master Air Valve
(required, for pump) | M Fluid Drain Valve (required) | Y Ground Wire (required; see page 7
for installation instructions) |
| F Pump Air Regulator | N Electrically Conductive Fluid Supply Hose | |
| G Air Manifold | | |

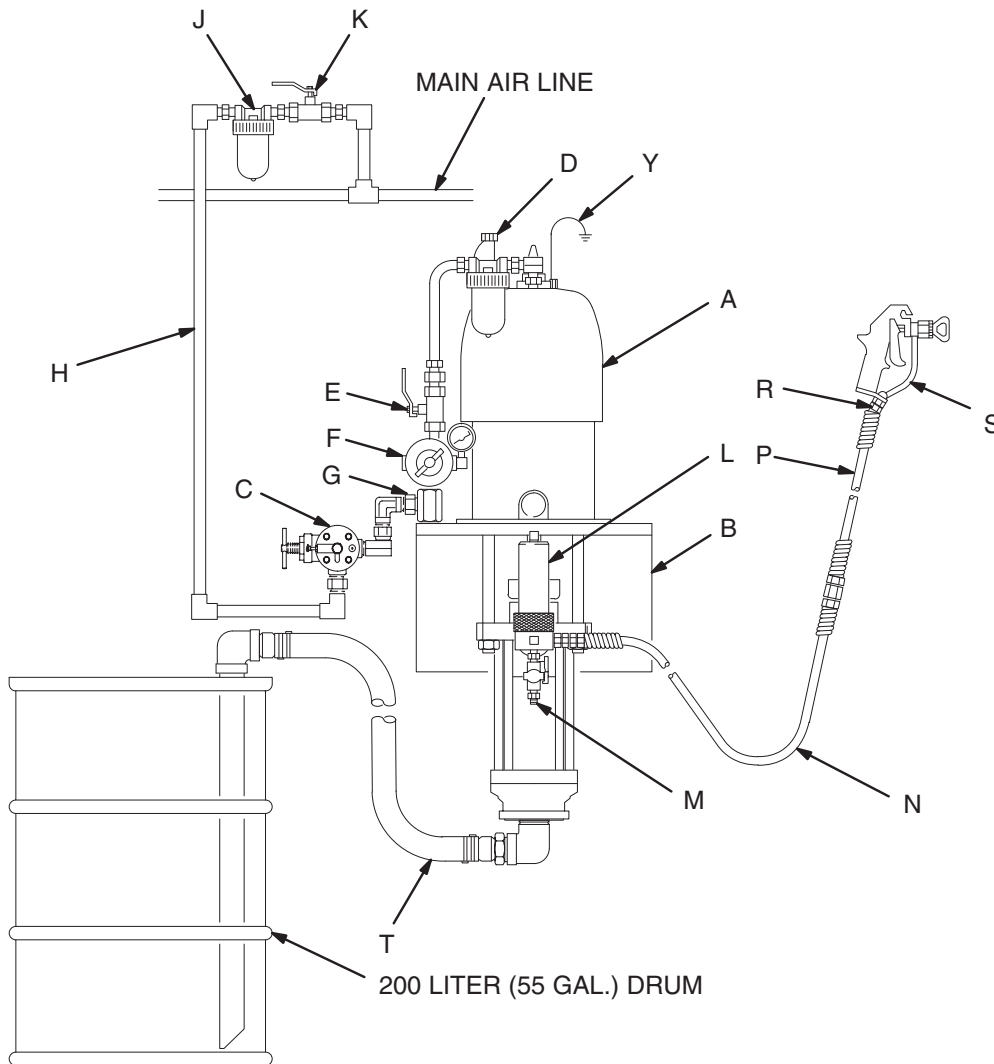

0626C

Fig. 4

Installation

(AIR-POWERED PUMPS)

System Accessories

WARNING

A bleed-type master air valve (E) and a fluid drain valve (M) are required in your system. These accessories help reduce the risk of serious injury, including fluid injection and splashing of fluid in the eyes or on the skin, and injury from moving parts if you are adjusting or repairing the pump.

The bleed-type master air valve relieves air trapped between this valve and the pump after the air is shut off. Trapped air can cause the pump to cycle unexpectedly. Locate the valve close to the pump.

The fluid drain valve assists in relieving fluid pressure in the displacement pump, hose, and gun. Triggering the gun to relieve pressure may not be sufficient.

Air and Fluid Hoses

Be sure all air hoses (H) and fluid hoses (N and P) are properly sized and pressure-rated for your system. Use only electrically conductive hoses. Fluid hoses must have spring guards on both ends. Use a whip hose (P) and a swivel (R) between the main fluid hose (N) and the gun/valve (S) for easier gun/valve movement.

Mounting Accessories

Mount the pump (A) to suit the type of installation planned. Fig. 4 illustrates a wall-mounted system. Pump dimensions and the mounting hole layout are shown on pages 44 and 45.

If you are using an elevator or a cart, refer to the separate manuals supplied with those components for installation and operation instructions.

Air Line Accessories

Install the following accessories in the order shown in Fig. 4, using adapters as necessary:

- **An air line lubricator (D)** provides automatic air motor lubrication.

- **A bleed-type master air valve (E)** is required in your system to relieve air trapped between it and the air motor when the valve is closed (see the **WARNING** at left). Be sure the bleed valve is easily accessible from the pump, and is located **down-stream** from the air regulator.
- **An air regulator (F)** controls pump speed and outlet pressure by adjusting the air pressure to the pump. Locate the regulator close to the pump, but **upstream** from the bleed-type master air valve.
- **A pump runaway valve (C)** senses when the pump is running too fast and automatically shuts off the air to the motor. A pump which runs too fast can be seriously damaged.
- **An air manifold (G)** has a swivel air inlet. It mounts to a wall bracket, and provides ports for connecting lines to air-powered accessories.
- **An air line filter (J)** removes harmful dirt and moisture from the compressed air supply.
- **A second bleed-type air valve (K)** isolates the air line accessories for servicing. Locate upstream from all other air line accessories.

Fluid Line Accessories

Install the following accessories in the positions shown in Fig. 4, using adapters as necessary:

- **A fluid filter (L)** with a 60 mesh (250 micron) stainless steel element, to filter particles from the fluid as it leaves the pump. It includes a **fluid drain valve (M)**, which is required in your system to relieve fluid pressure in the hose and gun (see the **WARNING** at left).
- **A gun or valve (S)** dispenses the fluid. The gun shown in Fig. 4 is an airless spray gun for light to medium viscosity fluids.
- **A gun swivel (R)** allows for easier gun movement.
- **A suction kit (T)** allows the pump to draw fluid from a 200 liter (55 gallon) drum.

Installation

(HYDRAULIC-POWERED PUMPS)

NOTE: Reference numbers and letters in parentheses in the text refer to the callouts in the figures and the parts drawing.

NOTE: Accessories are available from your Graco distributor. If you supply your own accessories, be sure they are adequately sized and pressure-rated to meet the system's requirements.

Fig. 5 is only a guide for selecting and installing system components and accessories. Contact your Graco distributor for assistance in designing a system to suit your particular needs.

CAUTION

Keep the hydraulic supply system clean at all times. Be sure that all hydraulic fluid lines are absolutely clean. Blow out the lines with air and flush thoroughly with solvent before connecting to the hydraulic motor, to avoid introducing harmful contaminants into the motor. Plug the hydraulic lines immediately when they are disconnected.

Do not exceed 37.8 liter/min (10 gpm) hydraulic oil volume to the motor, to avoid stalling the pump.

For optimum pump performance, keep the temperature of the hydraulic oil below 54 °C (130 °F).

KEY

- A Pump
- B Wall Bracket
- C Hydraulic Supply Line
- D Hydraulic Return Line
- E Drain Line (from pressure reducing valve)
- F Pressure Gauge
- G Flow Control Valve
- H Pressure Reducing Valve
- J Accumulator
- K Drain Line (from motor drip pan)
- L Fluid Filter
- M Fluid Drain Valve (required)
- N Electrically Conductive Fluid Supply Hose
- P Fluid Whip Hose
- R Gun/Valve Swivel

TYPICAL INSTALLATION

- S Airless Spray Gun or Dispensing Valve
- T Drum Suction Kit
- U Hydraulic Supply Line Shutoff Valve
- V Hydraulic Return Line Shutoff Valve
- Y Ground Wire (required, see page 7 for installation instructions)
- AA Hydraulic Return Line Filter

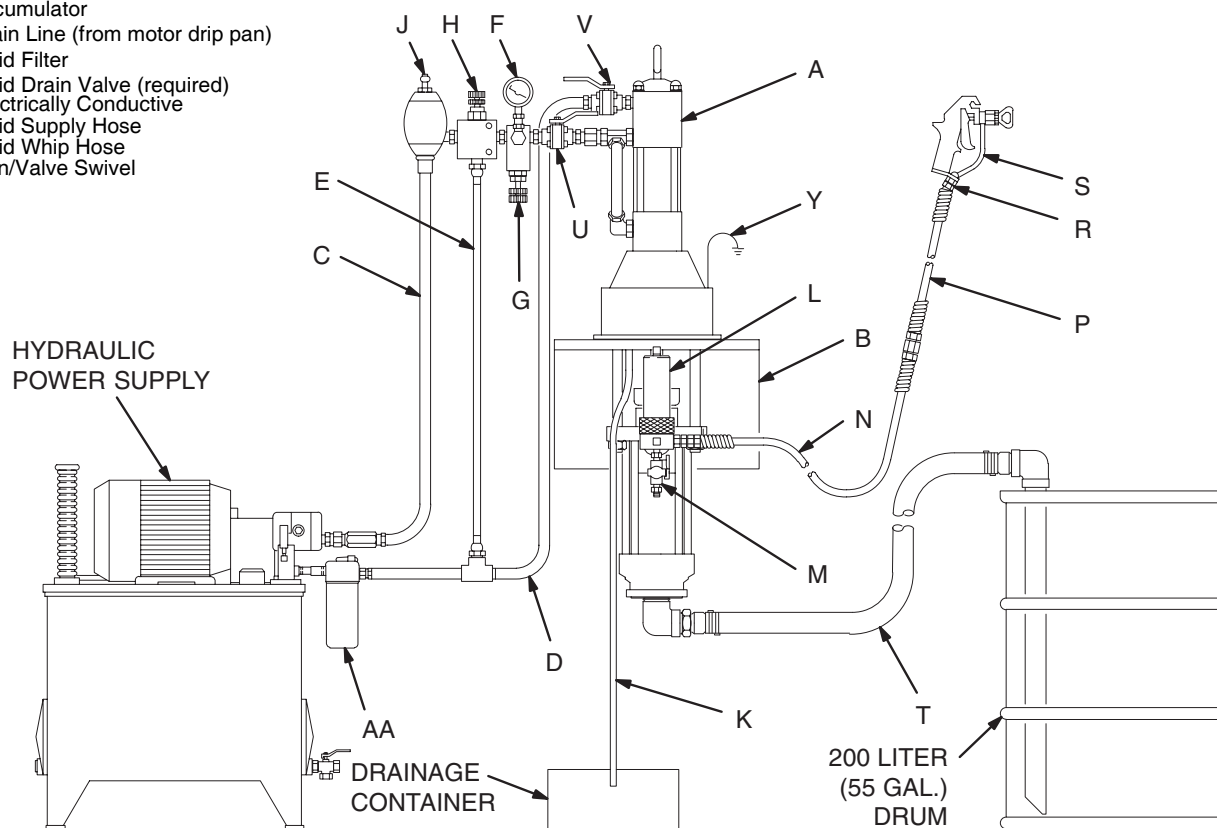

0627B

Fig. 5

Installation

(HYDRAULIC-POWERED PUMPS)

System Accessories

WARNING

A fluid drain valve (M) is required in your system to help reduce the risk of serious injury, including fluid injection and splashing of fluid in the eyes or on the skin if you are adjusting or repairing the pump. The fluid drain valve assists in relieving fluid pressure in the displacement pump, hose, and gun. Triggering the gun to relieve pressure may not be sufficient.

Mounting Accessories

Mount the pump (A) to suit the type of installation planned. Fig. 5 illustrates a wall-mounted system. Pump dimensions and the mounting hole layout are shown on pages 44 and 45.

Filters

Be sure your hydraulic power supply is equipped with a suction filter to the hydraulic pump and a system return line filter (AA) of 10 micron size.

Carefully follow the manufacturer's recommendations on reservoir and filter cleaning, and periodic changes of hydraulic fluid. Use only Graco-approved hydraulic oil. Order Part No. 169236, 19 liter (5 gal.) or Part No. 207428, 3.8 liter (1 gal.). Do not substitute a lower grade oil or one with a lower flash point.

Hydraulic Lines

The motor has a 3/4 npt(f) hydraulic oil supply fitting, and a 1 in. npt(f) hydraulic oil return fitting. Use a minimum 13 mm (1/2 in.) ID hydraulic supply line, and a minimum 22 mm (7/8 in.) ID return line.

On the hydraulic supply line (C), install the following accessories in the order shown in Fig. 5, using adapters as necessary:

- **A shutoff valve (U)** isolates the pump for service.
- **A fluid pressure gauge (F)** to monitor hydraulic oil pressure to the motor and to avoid overpressurizing the motor or displacement pump, and **a pressure and temperature compensated flow control valve (G)** to prevent the motor from running too fast and possibly damaging itself.
- **A pressure reducing valve (H), with a drain line (E)** run directly to the hydraulic return line (D).

- **An accumulator (J)** to reduce the hammering effect caused by the motor reversing direction.

On the hydraulic return line (D), install the following accessories in the order shown in Fig. 5, using adapters as necessary:

- **A shutoff valve (V)** isolates the pump for service.
- **A filter (AA)** of 10 micron size.

Hydraulic Motor Drip Pan

The hydraulic motor has a drip pan to collect any leakage. Connect a 6 mm (1/4 in.) ID drain line (K) to the barbed fitting on the drip pan, and place the free end in a container to receive the drainage.

Fluid Supply Hoses

Be sure all fluid supply hoses (N and P) are properly sized and pressure-rated for your system. Use only electrically conductive hoses. Fluid hoses must have spring guards on both ends. Use a whip hose (P) and a swivel (R) between the main fluid hose (N) and the gun/valve (S) to allow for easier gun/valve movement.

Fluid Line Accessories

Install the following accessories in the positions shown in Fig. 5, using adapters as necessary:

- **A fluid filter (L)** with a 60 mesh (250 micron) stainless steel element, to filter particles from the fluid as it leaves the pump. It includes a **fluid drain valve (M)**, which is required in your system to relieve fluid pressure in the hose and gun (see the **WARNING** at left).
- **A gun or valve (S)** dispenses the fluid. The gun shown in Fig. 5 is an airless spray gun for light to medium viscosity fluids.
- **A gun swivel (R)** allows for easier gun movement.
- **A suction kit (T)** allows the pump to draw fluid from a 200 liter (55 gallon) drum

Notes

Operation/Maintenance

(All PUMPS)

Pressure Relief Procedure

 **WARNING**

SKIN INJECTION HAZARD

The system pressure must be manually relieved to prevent the system from starting or spraying accidentally. Fluid under high pressure can be injected through the skin and cause serious injury. To reduce the risk of an injury from injection, splashing fluid, or moving parts, follow the **Pressure Relief Procedure** whenever you:

- are instructed to relieve the pressure,
- stop spraying,
- check or service any of the system equipment,
- or install or clean the spray tips.

1. Lock the gun trigger safety.
2. Shut off the air or hydraulic supply to the pump.
3. *In air-powered systems*, close the bleed-type master air valve (required in your system).

In hydraulic-powered systems, close the hydraulic supply line valve first, then the return line valve.
4. Unlock the gun trigger safety.
5. Hold a metal part of the gun firmly to the side of a grounded metal pail, and trigger the gun to relieve pressure.
6. Lock the gun trigger safety.
7. Open the drain valve (required in your system), having a container ready to catch the drainage.
8. Leave the drain valve open until you are ready to spray again.

If you suspect that the spray tip or hose is completely clogged, or that pressure has not been fully relieved after following the steps above, very slowly loosen the tip guard retaining nut or hose end coupling and relieve pressure gradually, then loosen completely. Now clear the tip or hose.

Packing Nut/Wet-Cup

Before starting, fill the packing nut (3) 1/3 full with Graco Throat Seal Liquid (TSL) or compatible solvent. See Fig. 6.

 **WARNING**

SKIN INJECTION HAZARD

To reduce the risk of serious injury whenever you are instructed to relieve pressure, always follow the **Pressure Relief Procedure** at left.

The packing nut is torqued at the factory and is ready for operation. If it becomes loose and there is leaking from the throat packings, **relieve pressure**, then torque the nut to 128–156 N•m (95–115 ft-lb) using the supplied wrench (104). Do this whenever necessary. Do not overtighten the packing nut.

Model 24Y192 Shown

 Bleed hole must face down

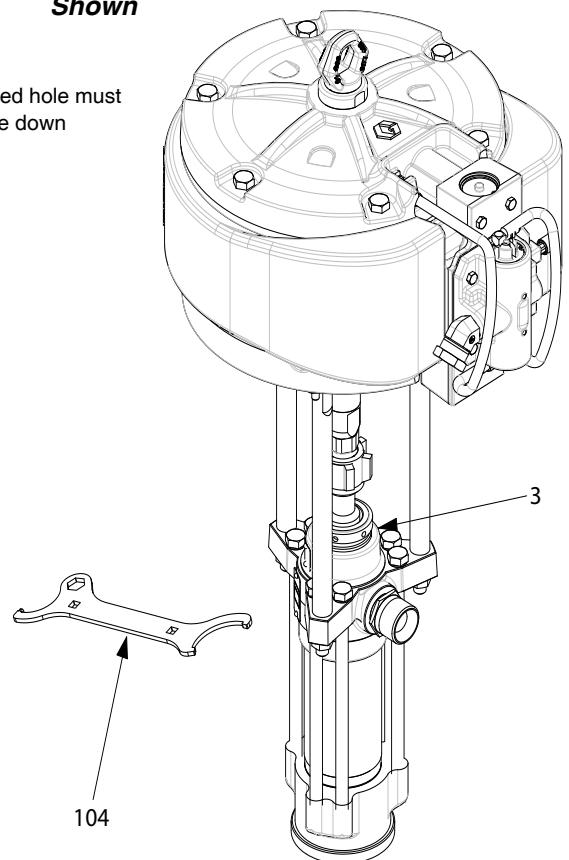

Fig. 6

Operation/Maintenance

(AIR-POWERED PUMPS)

Flush the Pump Before First Use

The pump is tested with lightweight oil, which is left into protect the pump parts. If the fluid you are using may be contaminated by the oil, flush it out with a compatible solvent. See **Flushing** on page 15.

Starting and Adjusting the Pump

1. Refer to the **Typical Installation** on page 8. Connect the suction kit (T) to the pump's fluid inlet, and place the tube into the fluid supply.
2. Be sure the air regulator (F) is closed. Then open the pump's bleed-type master air valve (E). Hold a metal part of the spray gun/dispersing valve firmly to the side of a grounded metal pail and hold the trigger open. Now slowly open the air regulator until the pump starts.
3. Cycle the pump slowly until all air is pushed out and the pump and hoses are fully primed. Release the gun/valve trigger and lock the trigger safety. The pump should stall against pressure when the trigger is released.

WARNING

SKIN INJECTION HAZARD

To reduce the risk of fluid injection, do not use your hand or fingers to cover the bleed hole on the underside of the bleeder valve body (34) when priming the pump. Use a crescent wrench to open and close the bleeder plug (35). Keep your hands away from the bleed hole.

4. If the pump fails to prime properly, open the bleeder valve plug (35) slightly. Use the bleed hole on the underside of the valve body (34) as a priming valve until the fluid appears at the hole. See Fig. 6. Close the plug (35).

NOTE: When changing fluid containers with the hose and gun already primed, open the bleeder valve plug (35) to help prime the pump and vent air before it enters the hose. Close the plug when all air is eliminated.

CAUTION

Do not allow the pump to run dry. It will quickly accelerate to a high speed, causing damage. If the pump is running too fast, stop it immediately and check the fluid supply. If the container is empty and air has been pumped into the lines, refill the container and prime the pump and the lines, or flush and leave it filled with a compatible solvent. Eliminate all air from the fluid system.

5. With the pump and lines primed, and with adequate air pressure and volume supplied, the pump will start and stop as the gun/valve is opened and closed. In a circulating system, the pump will speed up or slow down on demand, until the air supply is shut off.
6. Use the air regulator to control the pump speed and the fluid pressure. Always use the lowest air pressure necessary to get the desired results. Higher pressures cause premature tip/nozzle and pump wear.

WARNING

COMPONENT RUPTURE HAZARD

 To reduce the risk of overpressurizing your system, which could cause component rupture and serious injury, *never exceed the specified Maximum Incoming Air Pressure to the pump* (see the **Technical Data** section on pages 36–41).

Operation/Maintenance

(AIR-POWERED PUMPS)

Shutdown and Care of the Pump

WARNING

To reduce the risk of serious injury whenever you are instructed to relieve pressure, always follow the **Pressure Relief Procedure** on page 13.

For overnight shutdown, stop the pump at the bottom of its stroke to prevent fluid from drying on the exposed displacement rod and damaging the throat packings.

Relieve the pressure.

Always flush the pump before the fluid dries on the displacement rod. See **Flushing** below.

Flushing

WARNING



FIRE AND EXPLOSION HAZARD

Before flushing, read the section **FIRE AND EXPLOSION HAZARD** on page 5. Be sure the entire system and flushing pails are properly grounded. Refer to **Grounding** on page 7.

Flush with a fluid that is compatible with the fluid you are pumping and with the wetted parts in your system. Check with your fluid manufacturer or supplier for recommended flushing fluids and flushing frequency. Always flush the pump before fluid dries on the displacement rod.

WARNING

To reduce the risk of serious injury whenever you are instructed to relieve pressure, always follow the **Pressure Relief Procedure** on page 13.

1. **Relieve the pressure.**
2. Remove the spray tip from the gun.
3. Hold a metal part of the gun firmly to the side of a grounded *metal* pail.
4. Start the pump. Always use the lowest possible fluid pressure when flushing.
5. Trigger the gun.
6. Flush the system until clear solvent flows from the gun.
7. **Relieve the pressure.**

Operation/Maintenance

(HYDRAULIC-POWERED PUMPS)

Flush the Pump Before First Use

The pump is tested with lightweight oil, which is left in to protect the pump parts. If the fluid you are using may be contaminated by the oil, flush it out with a compatible solvent. See **Flushing** on page 17.

Starting and Adjusting the Pump

1. Refer to the **Typical Installation** on page 10. Connect the suction kit (T) to the pump's fluid inlet, and place the tube into the fluid supply.
2. Check the hydraulic fluid level before each use, and add fluid as necessary.
3. Make certain that the supply line shutoff valve (U) and the return line shutoff valve (V) are closed.
4. Start the hydraulic power supply.
5. Hold a metal part of the gun (S) firmly to the side of a grounded metal pail and hold the trigger open.
6. Open the return line shutoff valve (V) *first*, then slowly open the supply line shutoff valve (U).
7. Cycle the pump slowly until all air is pushed out and the pump and hoses are fully primed.
8. Release the gun trigger and lock the trigger safety. The pump should stall against pressure.

WARNING

SKIN INJECTION HAZARD

To reduce the risk of fluid injection, do not use your hand or fingers to cover the bleed hole on the underside of the bleeder valve body (34) when priming the pump. Use a crescent wrench to open and close the bleeder plug (35). Keep your hands away from the bleed hole.

9. If the pump fails to prime properly, open the bleeder valve plug (35) slightly. Use the bleed hole on the underside of the valve body (34) as a priming valve until the fluid appears at the hole. See Fig. 6. Close the plug (35).

NOTE: When changing fluid containers with the hose and gun already primed, open the bleeder valve plug (35) to help prime the pump and vent air before it enters the hose. Close the plug when all air is eliminated.

CAUTION

Do not allow the pump to run dry. It will quickly accelerate to a high speed, causing damage. If the pump is running too fast, stop it immediately and check the fluid supply. If the container is empty and air has been pumped into the lines, refill the container and prime the pump and the lines, or flush and leave it filled with a compatible solvent. Eliminate all air from the fluid system.

10. With the pump and lines primed, and with adequate hydraulic volume supplied, the pump will start and stop as you open and close the gun. In a circulating system, the pump will speed up or slow down on demand, until the hydraulic power supply is shut off.
11. Use the fluid pressure gauge (F) and flow control valve (G) to control the pump speed and the fluid outlet pressure. Always use the lowest hydraulic flow and pressure necessary to get the desired results. Higher pressures cause premature tip/nozzle and pump wear.

WARNING

COMPONENT RUPTURE HAZARD



To reduce the risk of overpressurizing your system, which could cause component rupture and serious injury, *never exceed 10.5 MPa, 105 bar (1500 psi) Maximum Hydraulic Input Pressure to the pump, 14.0 MPa, 140 bar (2000 psi) Maximum Fluid Working Pressure (see the **Technical Data** on pages 42–43).*

To prevent overpressurizing the hydraulic motor or its seals, always shut off the supply line valve (U) *first*, then shut off the return line valve (V).

CAUTION

Do not allow the hydraulic oil temperature to exceed 54 °C (130 °F). The pump seals will wear faster and leakage may occur if the pump is operated at higher oil temperatures.

Operation/Maintenance

(HYDRAULIC-POWERED PUMPS)

Shutdown and Care of the Pump

WARNING

To reduce the risk of serious injury whenever you are instructed to relieve pressure, always follow the **Pressure Relief Procedure** on page 13.

For overnight shutdown, stop the pump at the bottom of its stroke to prevent fluid from drying on the exposed displacement rod and damaging the throat packings.

Relieve the pressure.

Always flush the pump before the fluid dries on the displacement rod. See **Flushing** below.

Flushing

WARNING



FIRE AND EXPLOSION HAZARD

Before flushing, read the section **FIRE AND EXPLOSION HAZARD** on page 5. Be sure the entire system and flushing pails are properly grounded. Refer to **Grounding** on page 7.

Flush with a fluid that is compatible with the fluid you are pumping and with the wetted parts in your system. Check with your fluid manufacturer or supplier for recommended flushing fluids and flushing frequency. Always flush the pump before fluid dries on the displacement rod.

WARNING

To reduce the risk of serious injury whenever you are instructed to relieve pressure, always follow the **Pressure Relief Procedure** on page 13.

1. **Relieve the pressure.**
2. Remove the spray tip from the gun.
3. Hold a metal part of the gun firmly to the side of a grounded *metal* pail.
4. Start the pump. Always use the lowest possible fluid pressure when flushing.
5. Trigger the gun.
6. Flush the system until clear solvent flows from the gun.
7. **Relieve the pressure.**

Troubleshooting Chart

1. Relieve the pressure.

2. Check all possible causes and problems before disassembling the pump.



WARNING

To reduce the risk of serious injury whenever you are instructed to relieve pressure, always follow the **Pressure Relief Procedure** on page 13.

PROBLEM	CAUSE	SOLUTION
Pump fails to operate	Restricted line or inadequate air/hydraulic supply; closed or clogged valves	Clear; increase air/hydraulic supply. Check that valve are open.
	Obstructed fluid hose or gun/valve; fluid hose ID is too small	Open, clear*; use hose with larger ID.
	Fluid dried on the displacement rod	Clean; always stop pump at bottom of stroke; keep wet-cup 1/3 filled with compatible solvent.
	Dirty, worn, or damaged motor parts	Clean or repair; see separate motor manual.
Pump operates, but output low on both strokes	Restricted line or inadequate air/hydraulic supply, closed or clogged valves	Clear; increase air/hydraulic supply. Check that valves are open.
	Obstructed fluid hose or gun/valve; fluid hose ID is too small	Open clear*; use hose with larger ID.
	Bleeder valve open	Close.
	Fluid too heavy for pump priming	Use bleeder valve (see pages 14 and 16); use ram.
	Worn packings in displacement pump	Replace packings.
Pump operates, but output low on upstroke	Held open or worn intake valve	Clear valve; service.
	Fluid too heavy for pump priming	Use bleeder valve (see pages 14 and 16); use ram.
Pump operates, but output low on upstroke	Held open or worn piston valve or packings	Clear valve; replace packings.
Erratic or accelerated pump speed	Exhausted fluid supply	Refill and prime.
	Fluid too heavy for pump priming	Use bleeder valve (see pages 14 and 16); use ram.
	Held open or worn piston valve or packings	Clear valve; replace packings.
	Held open or worn intake valve	Clear valve; service.

* To determine if the fluid hose or gun is obstructed, follow the **Pressure Relief Procedure** on page 13. Disconnect the fluid hose and place a container at the pump fluid outlet to catch any fluid. Turn on the air/hydraulic power just enough to start the pump. If the pump starts when the air/hydraulic power is turned on, the obstruction is in the fluid hose or gun.

NOTE: If you experience air motor icing, call your Graco Distributor.

Service

Required Tools

- Set of socket wrenches
- Set of adjustable wrenches
- 24 in. adjustable wrench
- Torque wrench
- Rubber mallet
- Arbor press
- Soft wooden block (approx. 1 square ft in size)
- Large vise, with soft jaws
- Thread lubricant
- Anti-seize lubricant 222955
- Loctite® 2760™ or equivalent

NOTE: Service Tool 109508 is available as an accessory. This tool fits over the top of the displacement rod, making it easier to apply a 24 in. adjustable wrench or 3/4 in. drive socket when connecting or disconnecting the rod from the piston assembly.

Disconnecting the Displacement Pump

1. Flush the pump, if possible. Stop the pump at the bottom of its stroke.



WARNING

To reduce the risk of serious injury whenever you are instructed to relieve pressure, always follow the **Pressure Relief Procedure** on page 13.

2. **Relieve the pressure.**
3. Disconnect the air or hydraulic hose. Plug all hydraulic hoses immediately, to prevent contamination of the hydraulic system. Hold the fluid outlet fitting (4) with a wrench to keep it from being loosened while you disconnect the fluid hose.
4. Disconnect the displacement pump (105) from the motor (101) as follows. Be sure to note the relative position of the pump's fluid outlet to the air or hydraulic inlet of the motor. If the motor does not require servicing, leave it attached to its mounting.



CAUTION

Be sure to use at least two people when lifting, moving, or disconnecting the pump. This pump is too heavy for one person. If you are disconnecting the displacement pump from a motor which is still mounted (for example, on a wall bracket), be sure to support the displacement pump while it is being disconnected, to prevent it from falling and causing injury and property damage. Do this by securely bracing the pump, or by having at least two people hold it while another disconnects it.

If the pump is mounted on a cart, slowly tip the cart backward until the handle rests on the ground, then disconnect the displacement pump.

5. Using an adjustable wrench, unscrew the coupling nut (103) from the connecting rod adapter (102). Remove the coupling collars (108). Take care not to lose or drop them. See Fig. 7.
6. Hold the tie rod flats with a wrench to keep the rods from turning. Unscrew the nuts (106) from the tie rods (107). Carefully remove the displacement pump (105) from the motor (101).
7. Refer to page 22 for displacement pump service. To service the air or hydraulic motor, refer to the separate motor manual, supplied.

Service

Reconnecting the Displacement Pump

WARNING

To reduce the risk of pinching or injuring hands or fingers caught between the hydraulic motor drip pan and the coupling nut, always use connecting rod adapter 184595 and tie rods 184596 on model 222900 Viscount Pump. Never use connecting rod adapter 184451 and tie rods 184452 on Model 222900; those parts do not allow sufficient clearance between the drip pan and coupling nut.

NOTE: On XL10000™ models, ensure that the rod adapter (102) has not loosened during maintenance. Proper torque is necessary to prevent the rod adapter from loosening during the pump operation.

If the rod adapter (102) has loosened during maintenance, remove the adapter and apply Loctite® 2760™ (or equivalent) to the rod adapter and air motor piston threads, and then torque as specified in Fig. 7.

1. Use at least two people to hold the displacement pump while another reconnects it to the motor (see the **CAUTION** at left). Orient the pump's fluid outlet to the air or hydraulic inlet as was noted in step 4 under **Disconnecting the Displacement Pump**. Position the displacement pump (105) on the tie rods (107). See Fig. 7.

2. Screw the nuts (106) onto the tie rods (107) and torque as noted in Fig. 7.
3. Place the coupling nut (103) on the displacement rod (1), then place the coupling collars (108) into the nut. Screw the coupling nut onto the connecting rod adapter (102) loosely. Hold the connecting rod adapter flats with a wrench to keep it from turning. Use an adjustable wrench to tighten coupling nut. Torque as noted in Fig. 7.
4. Torque the packing nut (3) to 128–156 N•m (95–115 ft-lb).
5. Reconnect all hoses. Reconnect the ground wire if it was disconnected. Fill the wet-cup (3) 1/3 full of Graco Throat Seal Liquid or compatible solvent.
6. Turn on the air or hydraulic power supply. On hydraulic pumps, open the hydraulic return line valve first, then the supply line valve. Run the pump slowly to ensure that it is operating properly.

Service

**King, Bulldog, and Viscount Pumps
(Model 222899 shown)**

**XL10000™ Pumps
(Model 24Y192 shown)**

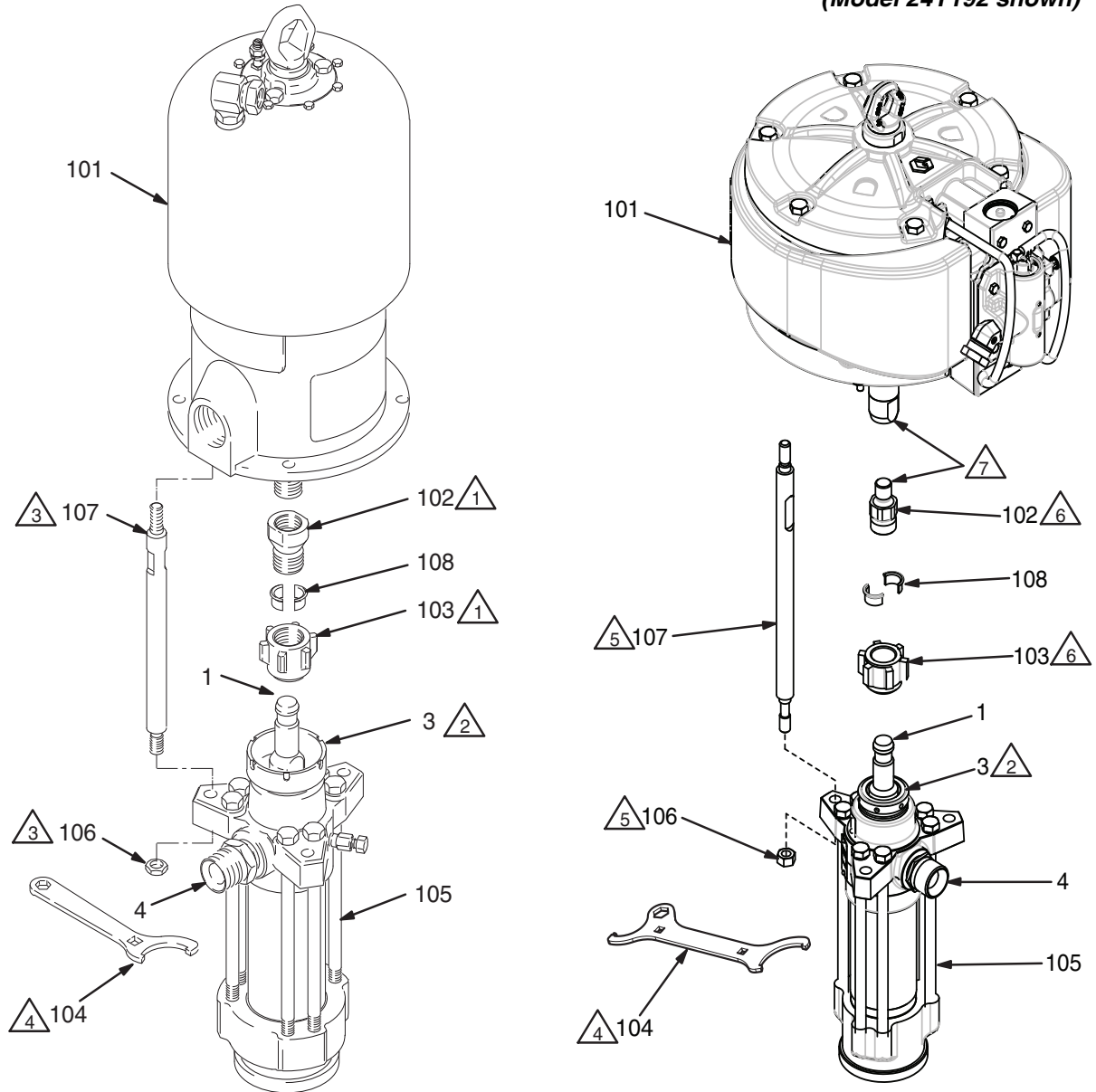

△1 Torque to 196–210 N•m (145–155 ft-lb)

△2 Torque to 128–156 N•m (95–115 ft-lb).

△3 Torque to 81–89 N•m (60–66 ft-lb)

△4 Square hole is for use with torque wrench.

△5 Torque to 129–142 N•m (95–105 ft-lb)

△6 Torque to 312–340 N•m (230–250 ft-lb)

△7 Apply Loctite® 2760™ (or equivalent) to threads.

Fig. 7

Service

Displacement Pump Service

Disassembly

When disassembling the pump, lay out all the removed parts in sequence, to ease reassembly. Clean all parts with a compatible solvent and inspect them for wear or damage. Refer to Fig. 8.

NOTE: Repair Kits are available to replace the throat (T) and piston (P) packings, and to replace the o-rings and cylinder seals. For the best results, use all the new parts in the kit. Kit parts are marked with an asterisk, for example (11*). These kits can also be used to convert the pump to different packing materials. Refer to pages 32 through 35.

NOTE: Standard Displacement Pump 222803 and optional displacement pumps 222994 and 241648 use stainless steel capscrews (20) with washers (36). Optional Pumps 222993, 236226, and 236230 use carbon steel cap screws and do not include washers.

1. Stand the displacement pump upright in a large vise. Loosen, but do not remove the packing nut (3). Remove the six long cap screws (20) and washers (36, if present), using a socket wrench.
2. Lift the outlet housing (19) straight up off the pump. Be careful not to scratch the displacement rod (1) while removing the housing.
3. Lift the cylinder (7), displacement rod (1), and piston assembly off the intake housing (17).
4. Remove the seal (6), ball guide (14), intake ball (16), intake seat housing (15), and o-ring (8) from the intake housing (17). Inspect the ball (16) and the ball seat (A) on the housing (15) for wear or damage.
5. Remove the seal (6) from the bottom of the outlet housing (19). Unscrew the packing nut (3). Remove the glands and v-packings (T) from the housing. Do not remove the outlet fitting (4) and o-ring (5) unless they need replacement.
6. Unscrew the bleeder valve plug (35) completely from the valve body (34). Clean the valve threads and the bleed hole. It is not necessary to remove the valve body from the pump outlet housing (19).
7. Stand the cylinder (7) upright on a wooden block. Using a rubber mallet or an arbor press, drive the displacement rod (1) and piston assembly down into the cylinder as far as possible, then place the cylinder on its side and continue to drive the rod out the bottom until the piston comes free. Pull the rod and piston from the cylinder, being careful not to scratch to rod or cylinder.

CAUTION

To reduce the possibility of costly damage to the rod (1) and cylinder (7), always use a rubber mallet or an arbor press to drive the rod out of the cylinder. Be sure to place the cylinder on a soft block of wood. Never use a hammer to drive the rod.

NOTE: Service Tool 109508 is available as an accessory. The tool fits over the top of the displacement rod (1), making it easier to apply a 24 inch adjustable wrench or 3/4 in. drive socket when disconnecting the rod from the piston assembly.

8. Put the flats of the piston seat housing (12) in a vise. Unscrew the rod (1) from the housing (12), leaving the ball guide (9) assembled to the rod. Be careful to catch the piston ball (10) as you separate the housing (12) and ball guide (9), so that it doesn't fall and suffer damage.
9. Remove the glands and v-packings (P) from the piston seat housing (12). Inspect the ball (10) and ball seat (B) on the housing (12) for wear or damage.
10. Inspect the outer surface of the displacement rod (1) and inner surface of the cylinder (7) for scoring or wear; replace either part if necessary. If the rod is being replaced, remove the ball guide (9) as explained in step 11.

NOTE: Do not remove the ball guide (9) from the displacement rod (1) unless either part is damaged.

11. Place the flats of the ball guide (9) in a vise. Using a 24 in. adjustable wrench or 3/4 in. drive socket, unscrew the rod (1) from the ball guide.

Service

 Included only on Displacement Pumps 222803, 222994, and 241648 with stainless steel cap screws (20).

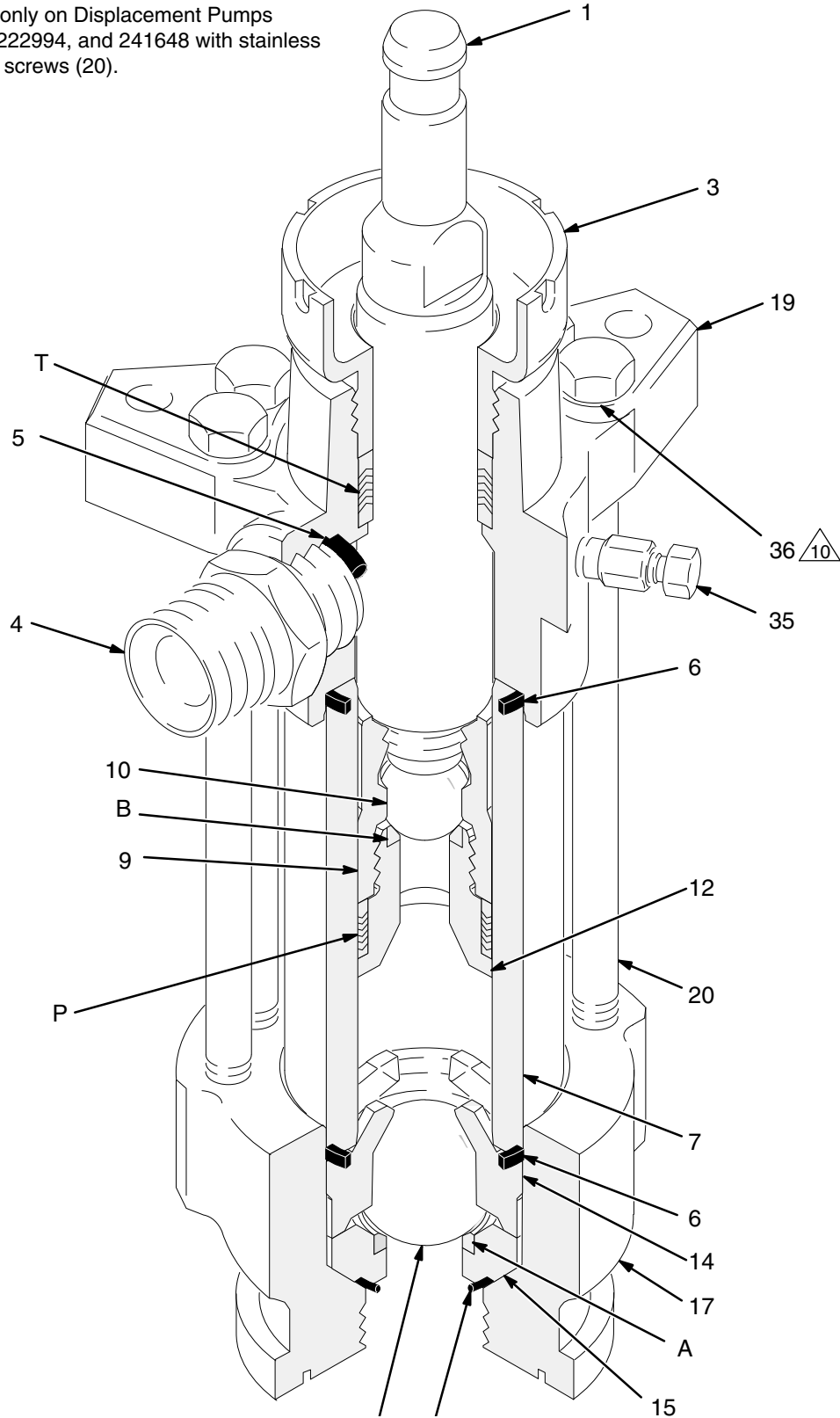

Fig. 8

Services

Reassembly

1. *If it was necessary to remove the ball guide (9) from the displacement rod (1),* place the flats of the rod in a vise. Apply anti-seize lubricant 222955 to the threads and mating faces of the rod and the ball guide. Screw the ball guide onto the rod, hand tight. Remove from the vise. See Fig. 9.
 2. Place the female gland (32*) on the piston seat housing (12). Install the five v-packings (P) one at a time with the lips facing up. Refer to pages 32 through 35 for the correct packing order for your pump. Install the male gland (13*).
- NOTE:** To convert the pump to a different packing material, see pages 32 through 35.
- NOTE:** Service Tool 109508 is available as an accessory. The tool fits over the top of the displacement rod (1), making it easier to apply a 24 inch adjustable wrench or 3/4 in. drive socket when connecting the rod to the piston assembly.
3. Apply anti-seize lubricant 222955 to the threads and mating faces of the ball guide (9) and piston seat housing (12). Place the flats of the piston seat housing in a vise. Place the ball (10) on the piston seat. Screw the assembled rod (1) and ball guide (9) onto the piston assembly hand tight, then torque to 444–492 N•m (327–363 ft-lb).
 4. Use an arbor press to reinstall the rod (1) into the cylinder (7), as follows. (The cylinder is symmetrical, so either end may face up). Lubricate the piston packings (P). With the piston end facing down, lower the rod into the cylinder. Start the piston into the cylinder as much as possible. then drive the rod and piston the rest of the way into the cylinder with the arbor press.

CAUTION

To reduce the possibility of costly damage to the rod (1) and cylinder (7), always use an arbor press to drive the rod into the cylinder, and be sure to place the cylinder on a soft block of wood. Never use a hammer to drive the rod.

5. Lubricate the o-ring (8*) and seal (6*). Install the o-ring on the intake seat housing (15). Install the intake seat housing (15), intake ball (16), ball guide (14), and seal (6*) in the intake housing (17). Set the intake housing all the way into the vise.

6. Place the cylinder (7) on the intake housing (17). Tap on the top of the displacement rod (1) with a rubber mallet, to seat the cylinder.
7. Lubricate the throat packings (T). Place the male gland (28*) into the outlet housing (19). Install the five v-packings one at a time **with the lips facing down**. Refer to pages 32 through 35 for the correct packing order for your pump. Install the female gland (25*).

NOTE: To convert the pump to a different packing material, see pages 32 through 35 .

8. Lubricate the threads of the packing nut (3), and loosely install it in the outlet housing (19).
9. Lubricate the seal (6*) and install it in the bottom of the outlet housing (19). Set the outlet housing on top of the cylinder (7). Apply thread lubricant to the six long cap screws (20). Install the washers (36, if present) and cap screws through the outlet housing (19) and thread them loosely by hand into the intake housing (17). Tighten the cap screws oppositely and evenly, using a socket wrench, then torque to 217–299 N•m (160–220 ft-lb).
10. Lubricate the threads of the bleeder valve plug (35). The plug has two sets of threads. Be sure to screw the plug completely into the valve body (34). Torque the plug to 31–37 N•m (23–27 ft-lb).

NOTE: It is not ordinarily necessary to remove the outlet fitting (4) and o-ring (5*). However, if they were replaced because of damage, lubricate the o-ring and place it on the fitting. Screw the fitting into the outlet housing (19). Torque to 141–185 N•m (104–136 ft-lb).

11. Reconnect the displacement pump to the motor as explained on page 20.

Service

1 Torque to 141–185 N•m (104–136 ft-lb)

2 Torque to 60–70 N•m (45–55 ft-lbs). For displacement pump 241648 only, limit packing nut torque to 27–40 N•m (20–30 ft-lb).

3 Torque to 444–492 N•m (327–363 ft-lb)

4 Torque oppositely and evenly to 217–299 N•m (160–220 ft-lb)

5 Apply anti-seize lubricant to threads and mating faces

6 Lubricate

7 Apply thread lubricant

8 Use arbor press to drive into cylinder (7)

9 Unscrew valve plug from valve housing and clean

10 Included only on Displacement Pumps 222803, 222994, and 241648 with stainless steel cap screws (20).

11 Torque to 31–37 N•m (23–27 ft-lb)

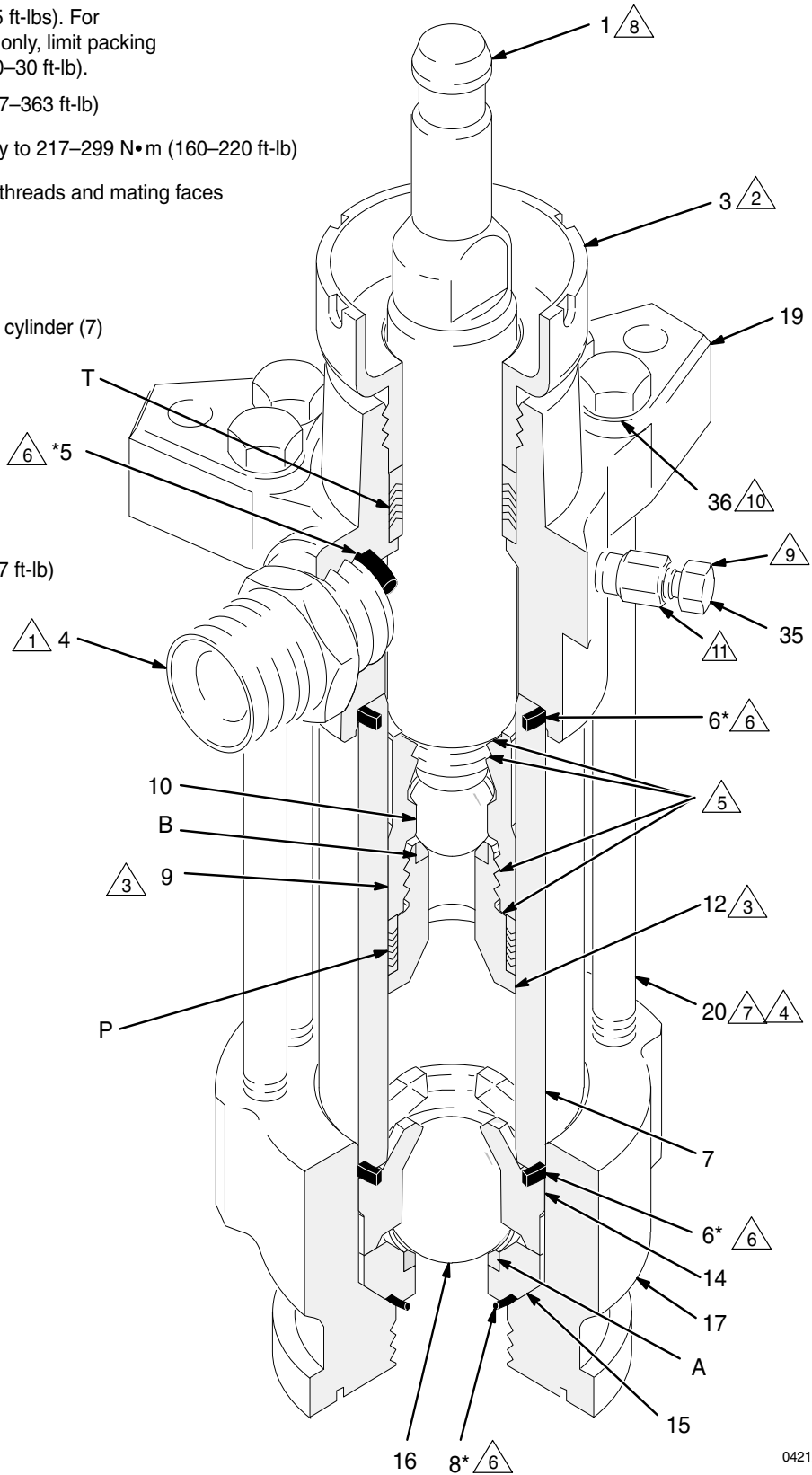

0421A

Fig. 9

Parts

Part No. 222827 Pump, Series A 10:1 Ratio, with Bulldog Air Motor

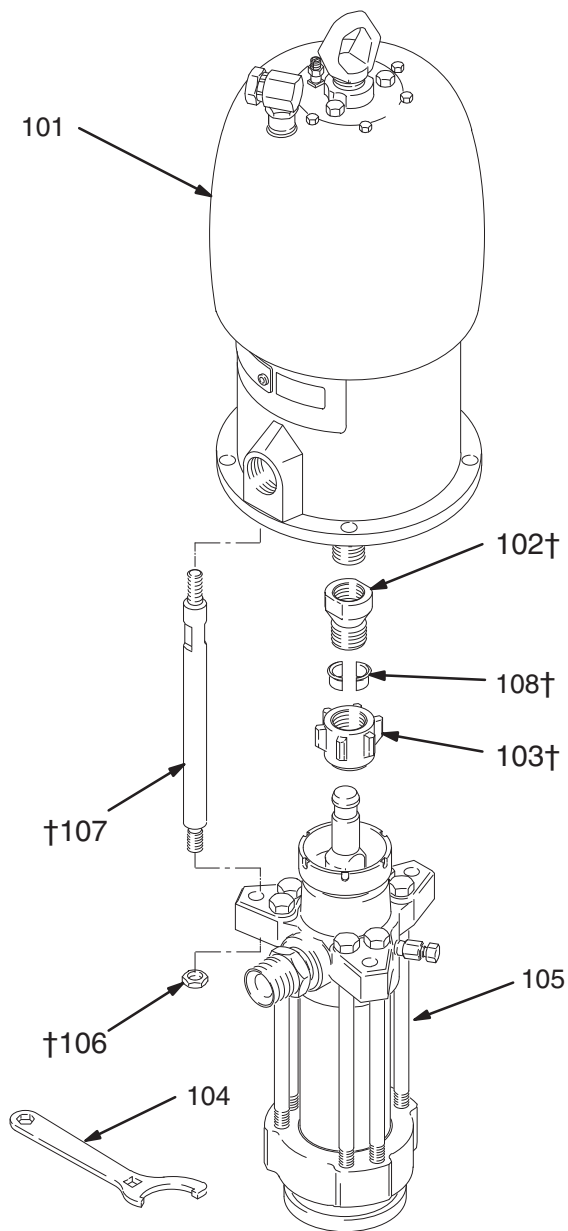

Ref. No.	Part No.	Description	Qty.
101	208356	AIR MOTOR, Bulldog See manual 307049 for parts	1
102†	184451	ADAPTER, connecting rod	1
103†	184096	NUT, coupling	1
104	184278	WRENCH, packing nut	1
105	222803	PUMP, displacement See pages 30 & 32 for parts	1
106†	106166	NUT, hex; M16 x 2.0	3
107†	184452	ROD, tie; 265 mm (10.43 in.) shoulder to shoulder; carbon steel	3
108†	184130	COLLAR, coupling	2

† For applications requiring stainless steel tie rods, order Connection Kit 222913.

0570B

Parts

Part No. 222899 Pump, Series B 20:1 Ratio, with King Air Motor

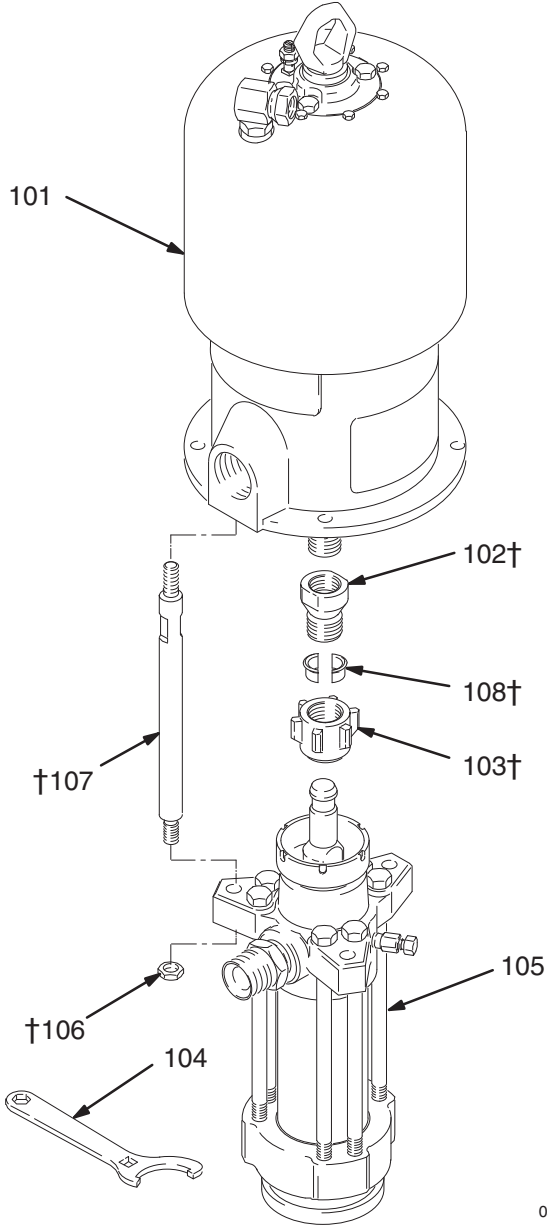

0567B

Part No. 222898 Pump, Series B 20:1 Ratio, with Quiet King Air Motor

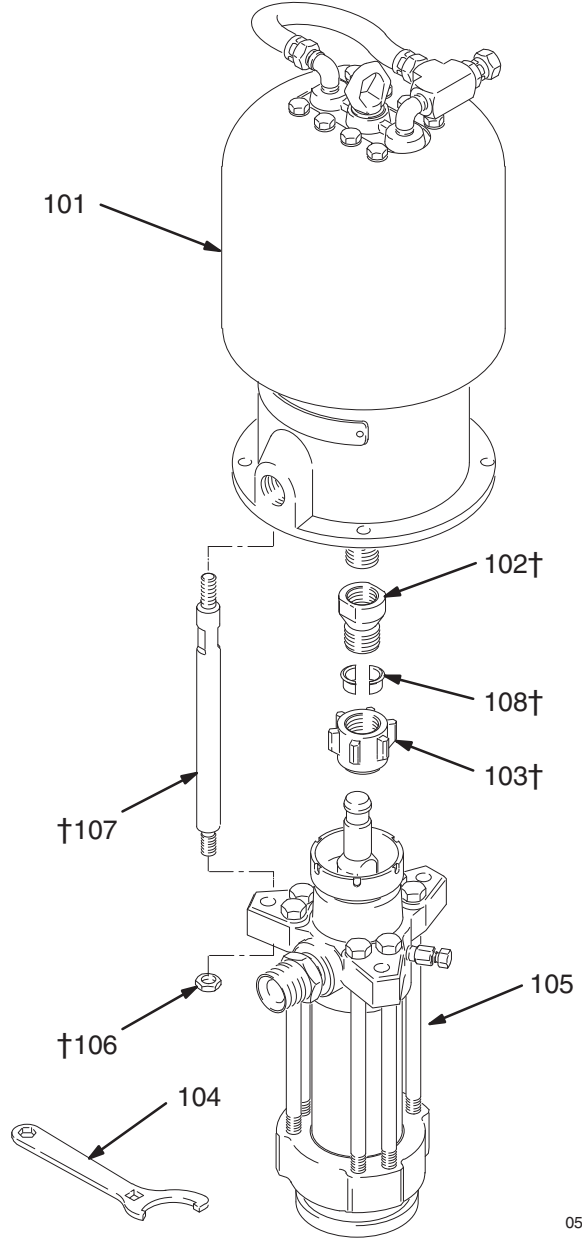

0568B

Ref. No.	Part No.	Description	Qty.
101	245111	AIR MOTOR, King See manual 309347 for parts	1
102†	184451	ADAPTER, connecting rod	1
103†	184096	NUT, coupling	1
104	184278	WRENCH, packing nut	1
105	222803	PUMP, displacement See pages 30 & 32 for parts	1
106†	106166	NUT, hex; M16 x 2.0	3
107†	184452	ROD, tie; 265 mm (10.43 in.) shoulder to shoulder; carbon steel	3
108†	184130	COLLAR, coupling	2

† For applications requiring stainless steel tie rods, order Connection Kit 222913.

Ref. No.	Part No.	Description	Qty.
101	220106	AIR MOTOR, King, quiet See manual 309348 for parts	1
102†	184451	ADAPTER, connecting rod	1
103†	184096	NUT, coupling	1
104	184278	WRENCH, packing nut	1
105	222803	PUMP, displacement See pages 30 & 32 for parts	1
106†	106166	NUT, hex; M16 x 2.0	3
107†	184452	ROD, tie; 265 mm (10.43 in.) shoulder to shoulder; carbon steel	3
108†	184130	COLLAR, coupling	2

† For applications requiring stainless steel tie rods, order Connection Kit 222913.

Parts

Part No. 24Y192 Pump, Series A 35:1 Ratio, with XL1000™ Air Motor

Part No. 24Y206 Pump, Series A 35:1 Ratio, with XL1000™ Air Motor

Ref. No.	Part No.	Description	Qty.
101	24Y400	AIR MOTOR, XL1000™	
102†	184582	See manual 334644 for parts ADAPTER, connecting rod	1 1
103†	184096	NUT, coupling	1
104†	184278	WRENCH, packing nut	1
105	249991	PUMP, displacement; used on Part No. 24Y192 and 24Y206; See pages 30 & 32 for parts	1 1
106†	106166	NUT, hex; M16 x 2.0	3
107†	184382	ROD, tie;380 mm (14.96 in.) shoulder to shoulder	3
108†	184130	COLLAR, coupling	2

† These parts are included in Connection Kit 235419.

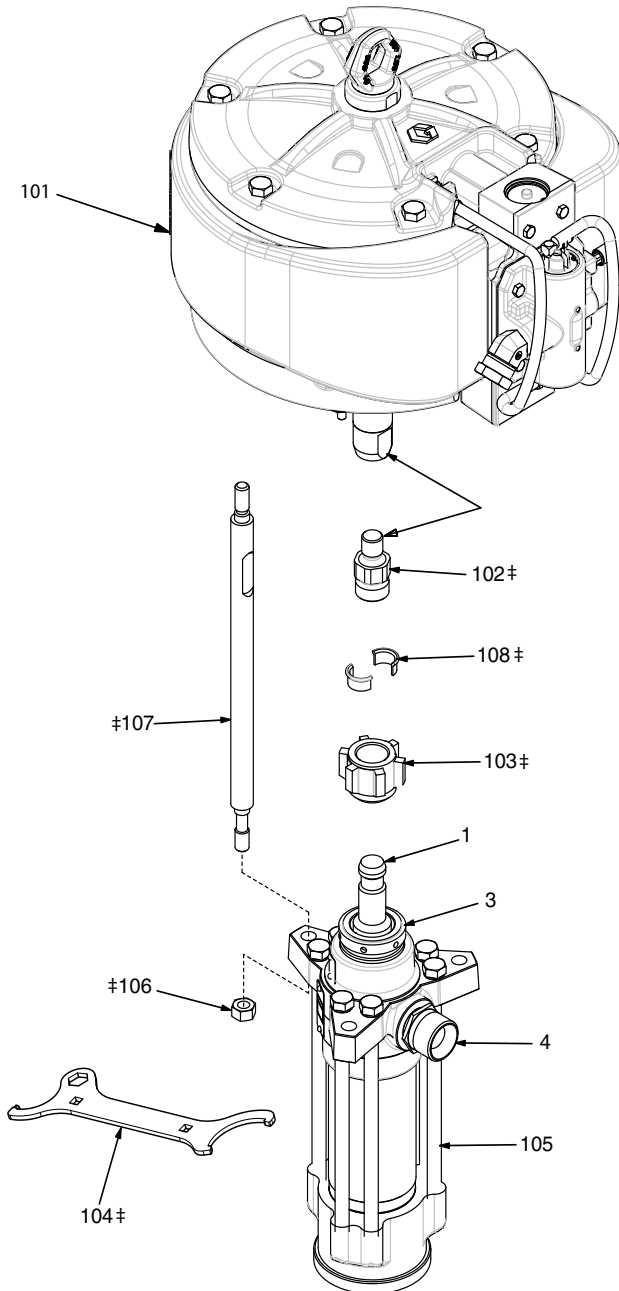

Parts

Part No. 222900 Pump, Series B with Viscount Hydraulic Motor

Ref. No.	Part No.	Description	Qty.
101	235345	HYDRAULIC MOTOR, Viscount See manual 307158 for parts	1
102†	184595	ADAPTER, connecting rod	1
103†	184096	NUT, coupling	1
104	184278	WRENCH, packing nut	1
105	222803	PUMP, displacement See pages 30 & 32 for parts	1
106†	106166	NUT, hex; M16 x 2.0	3
107†	184596	ROD, tie; 315 mm (12.40 in.) shoulder to shoulder	3
108†	184130	COLLAR, coupling	2

† These parts are included in Connection Kit 222976.

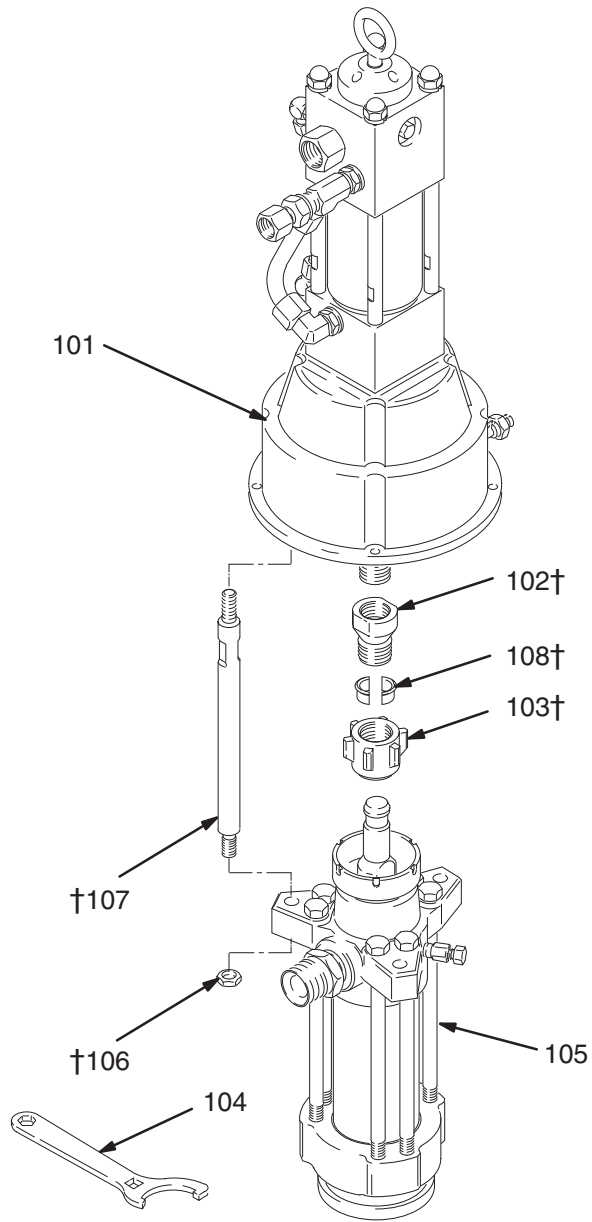

0569B

Displacement Pump Parts

NOTE: The parts listed on this page are common to all displacement pumps covered in this manual. The pumps use different packing configurations. Pump Models 222803, 222994, 241648, 15F298 and 249991 use stainless steel cap screws with washers. Models 222993, 236226, and 236230 use carbon steel cap screws without a washer. Refer to pages 32 through 35 for the different pump configurations available.

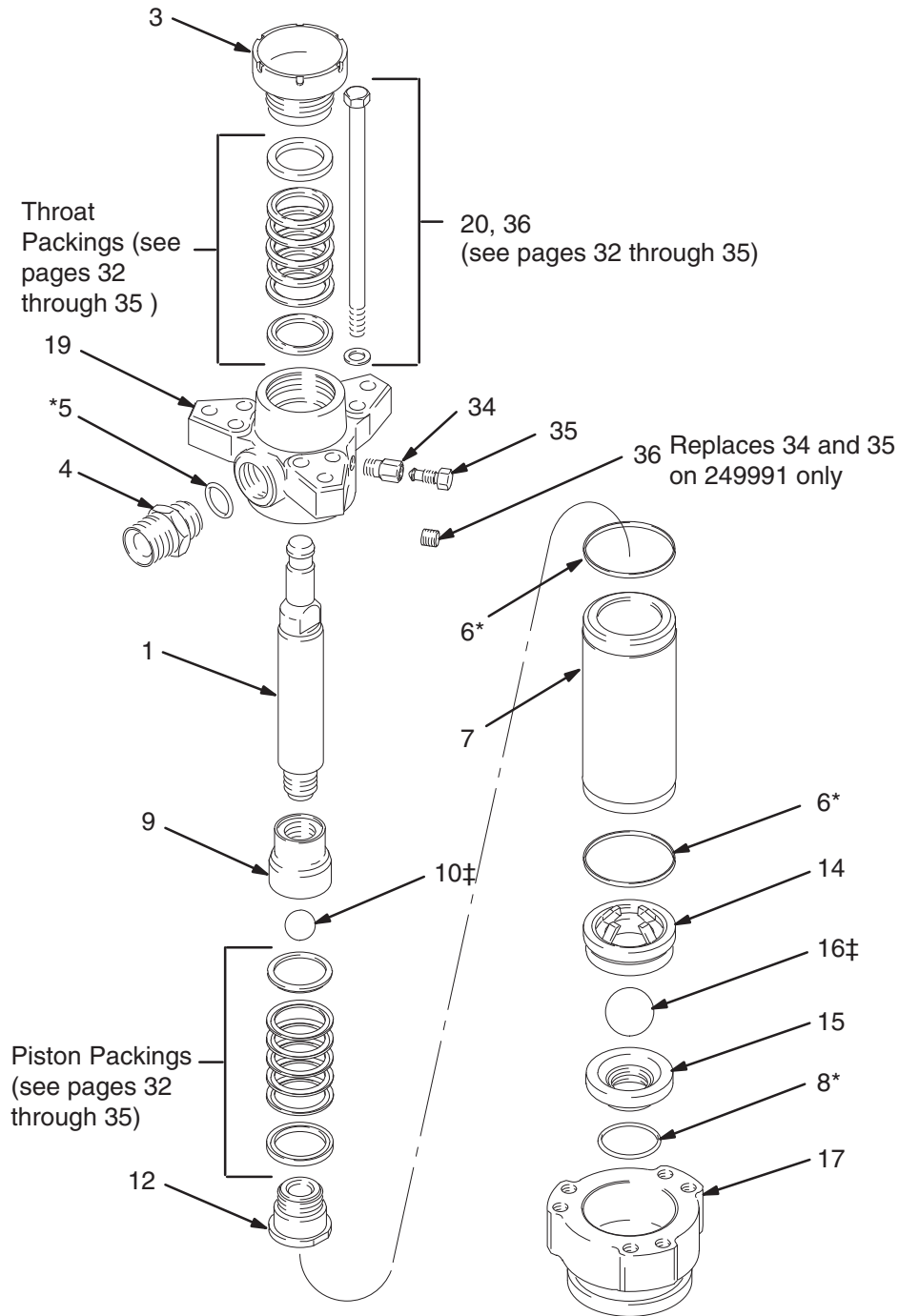

02257

Displacement Pump Parts

Ref No.	Part No.	Description	Qty	Ref Part No. No.	Description	Qty
1	184002	ROD, displacement; stainless steel	1	14 184282	GUIDE, ball, intake; stainless steel	1
	15G854	ROD, displacement; stainless steel (used on 249991 only)	1	15 222838	HOUSING, seat, intake valve; stainless steel w/tungsten carbide seat	1
3	24U018	PACKING NUT/WET-CUP; stainless steel	1	253742	HOUSING, valve, seat (used on 249991 only)	1
4	184387	FITTING, OUTLET; 1-1/2 in. npt(m) x M42 x 2.0; stainless steel; not used on Part No. 241648	1	16‡ 110294	BALL, intake; stainless steel; 2 in. (50.8 mm) dia.	1
5‡	109213	O-RING; PTFE; not used on Part No. 241648	1	15C868	BALL, intake; silicon nitride; 2 in. (50.8 mm) dia.;	1
6‡	184072	SEAL; acetal	2	17 184390	used on 15F298 and 249991 only HOUSING, intake; stainless steel	1
7	184003	CYLINDER, stainless steel	1	19 184389	HOUSING, outlet; stainless steel	1
	15G855	CYLINDER, pump (used on 249991 only)	1	34 184392	HOUSING, valve; 3/8-18 npt x 1/2 -20 unf-2a;	1
8‡	102857	O-RING; PTFE	1		Not included on 249991	1
9	184297	GUIDE, ball, piston; stainless steel	1	35 190293	PLUG, valve; 1/2-30 unf-2a; Not included on 249991	1
10‡	109220	BALL, piston; stainless steel; 1.5 in. (38.1 mm) dia.	1	36 101748	PLUG, (replaces 34 and 35 on 249991 only)	1
	119669	BALL, piston; silicon nitride; 1.5 in. (38.1 mm) dia.;	1			1
		used on 15F298 and 249991 only	1	*		
12	222802	HOUSING, seat, piston valve; stainless steel w/tungsten carbide seat	1		<i>These parts are included in Packing Repair Kit 222875 which may be purchased separately for standard Displacement Pump 222803.</i>	
	253741	HOUSING, valve, seat (used on 249991 only)	1	‡	<i>Keep these spare parts on hand to reduce down time.</i>	

Displacement Pump Parts

Standard Displacement Pumps

Displacement Pump 222803, Series A (UHMWPE and PTFE Packings, with Stainless Steel Cap Screws)

Ref Part No. No.	Description	Qty
11* 109266	V-PACKING; piston; UHMWPE	3
13* 184236	GLAND, male; piston; stainless steel	1
18* 109316	V-PACKING; piston; PTFE	2
20 109470	SCREW, cap, hex hd; 5/8-11 unc-2A x 12 in. (305 mm); stainless steel; <i>see page 30</i>	6
25* 184185	GLAND, female; throat; stainless steel	1
26* 109265	V-PACKING; throat; UHMWPE	3
27* 109315	V-PACKING; throat; PTFE	2
28* 184235	GLAND, male; throat; stainless steel	1
32* 184186	GLAND, female; piston; stainless steel	1
36 184618	WASHER, flat; stainless steel; <i>see page 30</i>	6

* These parts are included in Packing Repair Kit 222875, which may be purchased separately.

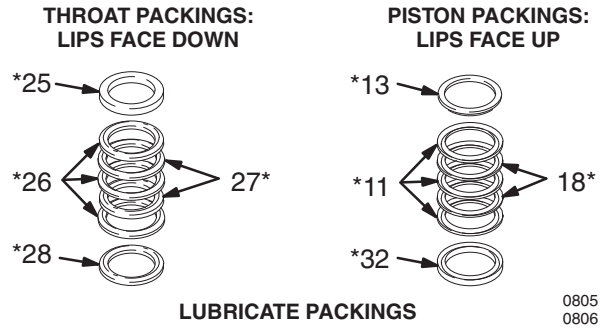

Displacement Pump 15F298, Series A (UHMWPE and Leather Packings)

NOTE: For this pump only, limit packing nut torque to 27–40 N•m (20–30 ft-lb).

Ref Part No. No.	Description	Qty
11* 109266	V-PACKING; piston; UHMWPE	3
13* 184236	GLAND, male; piston; stainless steel	1
20 109470	SCREW, cap, hex hd; 5/8-11 unc-2A x 12 in. (305 mm); stainless steel; <i>see page 30</i>	6
25* 184185	GLAND, female; throat; stainless steel	1
26* 109265	V-PACKING; throat; UHMWPE	3
28* 184235	GLAND, male; throat; stainless steel	1
32* 184186	GLAND, female; piston; stainless steel	1
33* 184316	V-PACKING; leather	2
34* 184315	V-PACKING; leather	4
36 184618	WASHER, flat; stainless steel; <i>see page 30</i>	6

* These parts are included in Packing Repair Kit 222881,

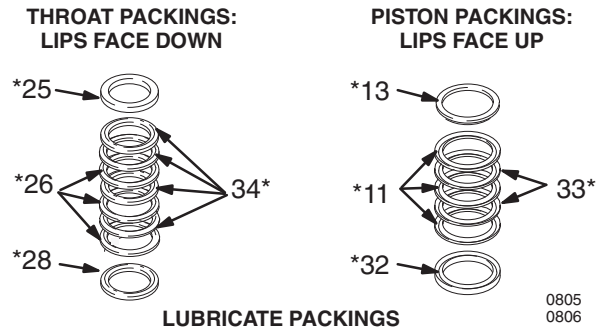

Displacement Pump Parts

Standard Displacement Pumps

Displacement Pump 249991, Series A, (UHMWPE Submicron and Leather Packings)

NOTE: For this pump only limit packing nut torques to 27–40 N•m (20–30 ft–lb).

Ref No.	Part No.	Description	Qty
11*	109266	V-PACKING; piston; UHMWPE	3
13*	184236	GLAND, male; piston; stainless steel	1
20	109470	SCREW, cap, hex hd; 5/8-11 unc-2A x 12 in. (305 mm); stainless steel; <i>see page 30</i>	6
25*	184185	GLAND, female; throat; stainless steel	1
26*	109265	V-PACKING; throat; UHMWPE	3
28*	184235	GLAND, male; throat; stainless steel	1
32*	184186	GLAND, female; piston; stainless steel	1
33*	120532	V-PACKING	2
34*	184315	V-PACKING; leather	4
36	184618	WASHER, flat; stainless steel; <i>see page 30</i>	6

* These parts are included in Packing Repair Kit 253745, which may be purchased separately.

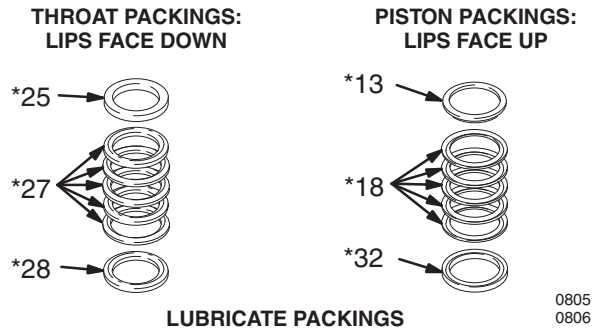

0805
0806

Optional Displacement Pumps

Displacement Pump 241648, Series A (UHMWPE and Carbon-Filled PTFE Packings, with Stainless Steel Cap Screws)

Carbon-filled PTFE for use with water up to 60° C (140° F)

NOTE: For this pump only, limit packing nut torque to 27–40 N•m (20–30 ft–lb).

Ref No.	Part No.	Description	Qty
11*	109266	V-PACKING; piston; UHMWPE	3
13*	184236	GLAND, male; piston; stainless steel	1
20	109470	SCREW, cap, hex hd; 5/8-11 unc-2A x 12 in. (305 mm); stainless steel; <i>see page 30</i>	6
25*	184185	GLAND, female; throat; stainless steel	1
26*	109265	V-PACKING; throat; UHMWPE	3
28*	184235	GLAND, male; throat; stainless steel	1
		GLAND, female; piston; stainless steel	1
32*	184186	V-PACKING; piston; PTFE	2
33*	109318	V-PACKING; throat; PTFE	2
34*	109317	V-PACKING; throat; PTFE	2
36	184618	WASHER, flat; stainless steel; <i>see page 30</i>	6

* These parts are included in Packing Repair Kit 222880, which may be purchased separately.

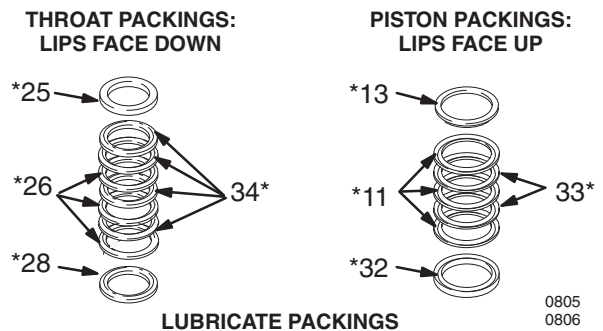

0805
0806

Displacement Pump Parts

Optional Displacement Pumps

Displacement Pump 236226, Series A (UHMWPE and PTFE Packings, with Carbon Steel Cap Screws)

Ref No.	Part No.	Description	Qty
11*	109266	V-PACKING; piston; UHMWPE	3
13*	184236	GLAND, male; piston; stainless steel	1
18*	109316	V-PACKING; piston; PTFE	2
20	109203	SCREW, cap, hex hd; 5/8-11 unc-2A x 12 in. (305 mm); carbon steel; see page 30	6
25*	184185	GLAND, female; throat; stainless steel	1
26*	109265	V-PACKING; throat; UHMWPE	3
27*	109315	V-PACKING; throat; PTFE	2
28*	184235	GLAND, male; throat; stainless steel	1
32*	184186	GLAND, female; piston; stainless steel	1

* The replacements for these parts are available in Packing Repair Kit 222875. Purchase the kit separately.

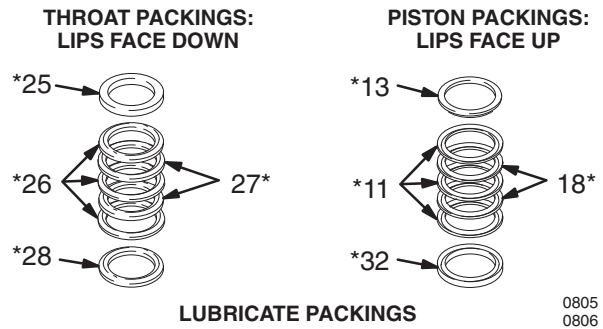

Wetted Parts: Chrome, Zinc, and Electroless Nickel Plating; 304, 329 and 17-4 PH Grades of Stainless Steel; Tungsten Carbide; acetal; PTFE; UHMWPE

Displacement Pump 222994, Series A, (PTFE Packings, with Stainless Steel Cap Screws)

Ref No.	Part No.	Description	Qty
13*	184236	GLAND, male; piston; stainless steel	1
18*	109316	V-PACKING; piston; PTFE	5
20	109470	SCREW, cap, hex hd; 5/8-11 unc-2A x 12 in. (305 mm); stainless steel; see page 30	6
25*	184185	GLAND, female; throat; stainless steel	1
27*	109315	V-PACKING; throat; PTFE	5
28*	184235	GLAND, male; throat; stainless steel	1
32*	184186	GLAND, female; piston; stainless steel	1
36	184618	WASHER, flat; stainless steel; see page 30	6

* The replacements for these parts are available in Packing Repair Kit 222876. Purchase the kit separately.

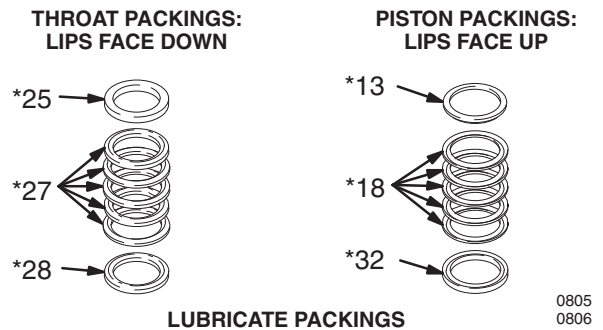

Wetted Parts: Chrome, Zinc, and Electroless Nickel Plating; 304, 329 and 17-4 PH Grades of Stainless Steel; Tungsten Carbide; acetal; PTFE

Displacement Pump Parts

Optional Displacement Pumps

Displacement Pump 236230, Series A, (Leather Packings and PTFE Backup, with Carbon Steel Cap Screws)

Ref No.	Part No.	Description	Qty
13*	184236	GLAND, male; piston; stainless steel	1
18*	109316	V-PACKING; piston; PTFE	3
20	109203	SCREW, cap, hex hd; 5/8-11 unc-2A x 12 in. (305 mm); carbon steel; see page 30	6
25*	184185	GLAND, female; throat; stainless steel	1
27*	109315	V-PACKING; throat; PTFE	3
28*	184235	GLAND, male; throat; stainless steel	1
29*	184316	V-PACKING; piston; leather	2
30*	184315	V-PACKING; throat; leather	2
32*	184186	GLAND, female; piston; stainless steel	1

* The replacements for these parts are available in Packing Repair Kit 222879. Purchase the kit separately.

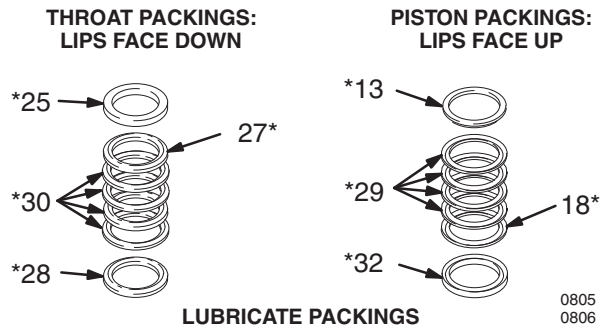

Wetted Parts: Chrome, Zinc, and Electroless Nickel Plating; 304, 329 and 17-4 PH Grades of Stainless Steel; Tungsten Carbide; acetal; PTFE; Leather

Displacement Pump 222993, Series A, (PTFE and Leather Packings, with Carbon Steel Cap Screws)

Ref No.	Part No.	Description	Qty
13*	184236	GLAND, male; piston; stainless steel	1
18*	109316	V-PACKING; piston; PTFE	1

Ref No.	Part No.	Description	Qty
20	109203	SCREW, cap, hex hd; 5/8-11 unc-2A x 12 in. (305 mm); carbon steel; see page 30	6
25*	184185	GLAND, female; throat; stainless steel	1
27*	109315	V-PACKING; throat; PTFE	1
28*	184235	GLAND, male; throat; stainless steel	1
29*	184316	V-PACKING; piston; leather	4
30*	184315	V-PACKING; throat; leather	4
32*	184186	GLAND, female; piston; stainless steel	1

* The replacements for these parts are available in Packing Repair Kit 222877. Purchase the kit separately.

Max-Life Conversion Kit 288552, Series A, Includes parts to convert existing Dura-Flo 2400 displacement pump (15F298) to Max-Life displacement pump (249991).

Ref No.	Part No.	Description	Qty
1	15G854	Rod	1
7	15G855	Cylinder	1
11*	109266	V-PACKING; piston; UHMWPE	3
12	253741	Housing	1
13*	184236	GLAND, male; piston; stainless steel	1
15	253742	Housing	1
20	109470	SCREW, cap, hex hd; 5/8-11 unc-2A x 12 in. (305 mm); stainless steel; see page 30	6
25*	184185	GLAND, female; throat; stainless steel	1

Ref No.	Part No.	Description	Qty
26*	109265	V-PACKING; throat; UHMWPE	3
28*	184235	GLAND, male; throat; stainless steel	1
32*	184186	GLAND, female; piston; stainless steel	1
33*	120532	V-PACKING	2
34*	184315	V-PACKING; leather	4
36	184618	WASHER, flat; stainless steel; see page 30	6

* The replacements for these parts are available in Packing Repair Kit 253745, which can be purchased separately

Refer to page 30 for assembly detail.

Technical Data (Bulldog Pumps)

WARNING

Be sure that all fluids and solvents used are chemically compatible with the Wetted Parts listed below. Always read the manufacturer's literature before using fluid or solvent in this pump.

Category	Data
Ratio	10:1
Maximum fluid working pressure	7.0 MPa, 70 bar (1000 psi)
Maximum air input pressure	0.7 MPa, 7 bar (100 psi)
Pump cycles per 3.8 liters (1 gal.)	6.5
Fluid flow at 60 cpm	46 liters/min (12 gpm)
Air motor piston effective area	248 cm ² (38.5 in. ²)
Stroke length	120 mm (4.75 in.)
Displacement pump effective area	24 cm ² (3.72 in. ²)
Maximum pump operating temperature	82° C (180° F)
Air inlet size	3/4 npsm(f)
Fluid inlet size	2 in. npt(f)
Fluid outlet size	1-1/2 npt(m)
Weight	approx. 61 kg (134 lb)
Wetted parts	304, 329 and 17-4 PH Grades of Stainless Steel; Tungsten Carbide; acetal, PTFE, Ultra-High Molecular Weight Polyethylene

Sound Pressure Levels (dBa)

(measured at 1 meter from unit)

Air Motor	Input Air Pressures at 15 cycles per minute			
	0.28 MPa, 2.8 bar (40 psi)	0.48 MPa, 4.8 bar (70 psi)	0.63 MPa, 6.3 bar (90 psi)	0.7 MPa, 7 bar (100 psi)
Bulldog	82.4	87.3	88.5	90.0

Sound Power Levels (dBa)

(tested in accordance with ISO 9614-2)

Air Motor	Input Air Pressures at 15 cycles per minute			
	0.28 MPa, 2.8 bar (40 psi)	0.48 MPa, 4.8 bar (70 psi)	0.63 MPa, 6.3 bar (90 psi)	0.7 MPa, 7 bar (100 psi)
Bulldog	91.6 dB(A)	95.9 dB(A)	97.4 dB(A)	98.1 dB(A)

Technical Data (Bulldog Pumps)

Performance Charts: Standard Bulldog Pumps

To find Fluid Outlet Pressure (psi/MPa/bar) at a specific fluid flow (lpm/gpm) and operating air pressure (psi/MPa/bar):

1. Locate desired flow along bottom of chart.
2. Follow vertical line up to intersection with selected fluid outlet pressure curve (black). Follow left to scale to read fluid outlet pressure.

To find Pump Air Consumption (m³ /min or scfm) at a specific fluidflow (lpm/gpm) and air pressure (psi/MPa/bar):

1. Locate desired flow along bottom of chart.
2. Read vertical line up to intersection with selected air consumption curve (dashes). Follow left to scale to read air consumption.

- A** 0.7 MPa, 7 bar (100 psi) air pressure
B 0.5 MPa, 4.9 bar (70 psi) air pressure
C 0.3 MPa, 2.8 bar (40 psi) air pressure

Test Fluid: No. 10 Weight Oil

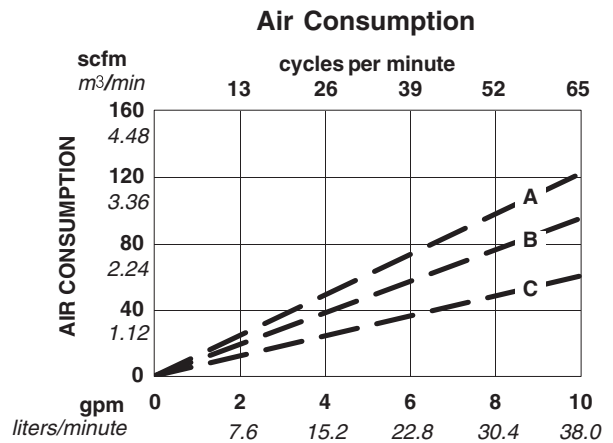
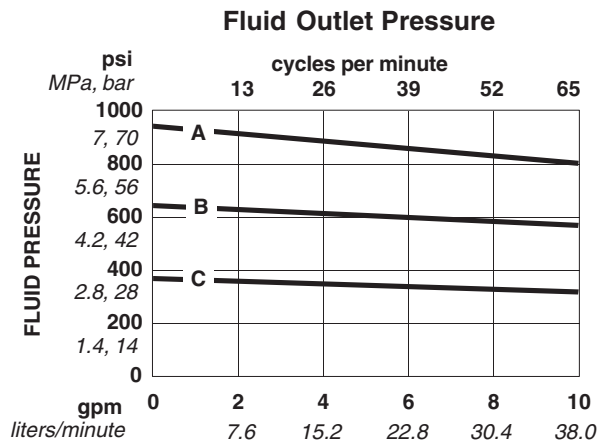

Technical Data (King Pumps)

WARNING

Be sure that all fluids and solvents used are chemically compatible with the Wetted Parts listed below. Always read the manufacturer's literature before using fluid or solvent in this pump.

Category	Data
Ratio	20:1
Maximum fluid working pressure	13.8 MPa, 138 bar (2000 psi)
Maximum air input pressure	0.7 MPa, 7 bar (100 psi)
Pump cycles per 3.8 liters (1 gal.)	6.5
Fluid flow at 50 cpm	46 liters/min (12 gpm)
Air motor piston effective area	506 cm ² (78.5 in. ²)
Stroke length	120 mm (4.75 in.)
Displacement pump effective area	24 cm ² (3.72 in. ²)
Maximum pump operating temperature	82° C (180° F)
Air inlet size	3/4 npsm(f)
Fluid inlet size	2 in. npt(f)
Fluid outlet size	1-1/2 in. npt(m)
Weight	approx. 69 kg (162 lb)
Wetted parts	304, 329 and 17-4 PH Grades of Stainless Steel; Tungsten Carbide; acetal, PTFE, Ultra-High Molecular Weight Polyethylene

Sound Pressure Levels (dBa)

(measured at 1 meter from unit)

Air Motor	Input Air Pressures at 15 cycles per minute		
	0.28 MPa, 2.8 bar (40 psi)	0.48 MPa, 4.8 bar (70 psi)	0.63 MPa, 6.3 bar (90 psi)
King	78.8	82.7	90.5
Quiet King	77.9	79.2	87.5

Sound Power Levels (dBa)

(tested in accordance with ISO 9614-2)

Air Motor	Input Air Pressures at 15 cycles per minute		
	0.28 MPa, 2.8 bar (40 psi)	0.48 MPa, 4.8 bar (70 psi)	0.63 MPa, 6.3 bar (90 psi)
King	86.5	88.8	97.7
Quiet King	85.2	86.6	95.2

Technical Data (King Pumps)

Performance Charts: Standard King Pumps

To find Fluid Outlet Pressure (psi/MPa/bar) at a specific fluid flow (lpm/gpm) and operating air pressure (psi/MPa/bar):

1. Locate desired flow along bottom of chart.
2. Follow vertical line up to intersection with selected fluid outlet pressure curve (black). Follow left to scale to read fluid outlet pressure.

To find Pump Air Consumption (m³/min or scfm) at a specific fluidflow (lpm/gpm) and air pressure (psi/MPa/bar):

1. Locate desired flow along bottom of chart.
2. Read vertical line up to intersection with selected air consumption curve (dashes). Follow left to scale to read air consumption.

- A 0.6 MPa, 6.3 bar (90 psi) air pressure
- B 0.5 MPa, 4.9 bar (70 psi) air pressure
- C 0.3 MPa, 2.8 bar (40 psi) air pressure

Test Fluid: No. 10 Weight Oil

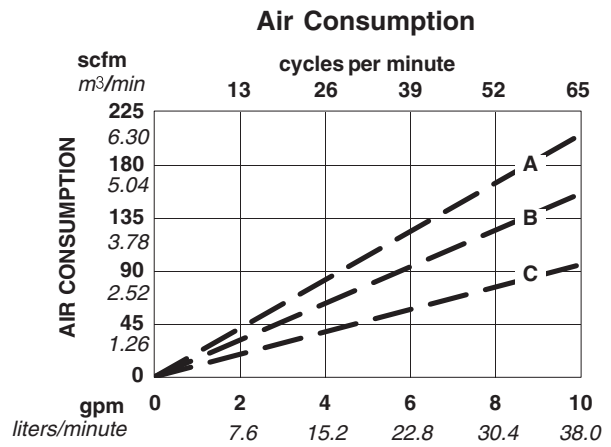
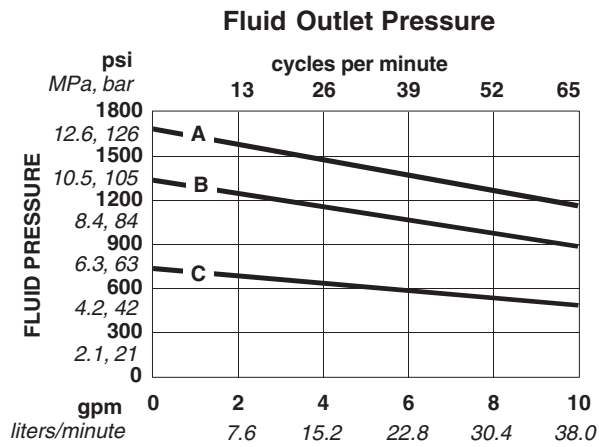

Performance Charts: Quiet King Pumps

To find Fluid Outlet Pressure (psi/MPa/bar) at a specific fluid flow (lpm/gpm) and operating air pressure (psi/MPa/bar):

1. Locate desired flow along bottom of chart.
2. Follow vertical line up to intersection with selected fluid outlet pressure curve (black). Follow left to scale to read fluid outlet pressure.

To find Pump Air Consumption (m³/min or scfm) at a specific fluidflow (lpm/gpm) and air pressure (psi/MPa/bar):

1. Locate desired flow along bottom of chart.
2. Read vertical line up to intersection with selected air consumption curve (dashes). Follow left to scale to read air consumption.

- A 0.6 MPa, 6.3 bar (90 psi) air pressure
- B 0.5 MPa, 4.9 bar (70 psi) air pressure
- C 0.3 MPa, 2.8 bar (40 psi) air pressure

Test Fluid: No. 10 Weight Oil

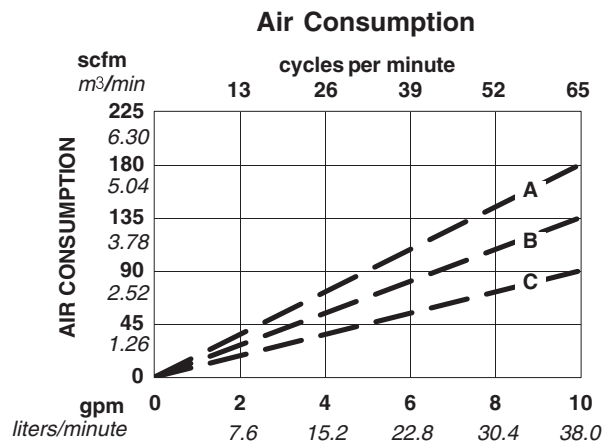
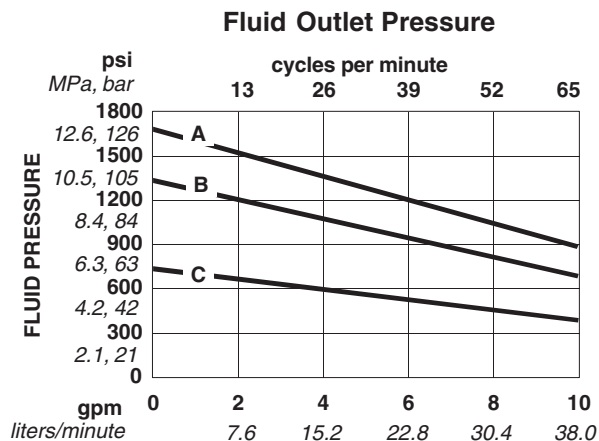

Technical Data (XL10000™ Pump)

WARNING

Be sure that all fluids and solvents used are chemically compatible with the Wetted Parts listed below. Always read the manufacturer's literature before using fluid or solvent in this pump.

Category	Data
Ratio	35:1
Maximum fluid working pressure	23.0 MPa, 234 bar (3400 psi)
Maximum air input pressure	0.7 MPa, 7 bar (100 psi)
Pump cycles per 3.8 liters (1 gal.)	6.5
Fluid flow at 60 cpm	34.6 liters/min (9.2 gpm)
Air motor piston effective area	856 cm ² (38.5 in. ²)
Stroke length	122 mm (4.8 in.)
Displacement pump effective area	24 cm ² (3.72 in. ²)
Maximum pump operating temperature	82° C (180° F)
Air inlet size	1 in. npt(f)
Fluid inlet size	2 in. npt(f)
Fluid outlet size	1-1/2 in. npt(m) or M42 x 2.0 (Part No. 241648 only)
Weight	approx. 106 kg (234 lb)
Wetted parts	304, 329 and 17-4 PH Grades of Stainless Steel; Tungsten Carbide; acetal, PTFE, Ultra-High Molecular Weight Polyethylene, Carbon-Filled PTFE (Part No. 241648 only)
Wetted parts (LASD Pumps 24Y192 and 24Y206)	304, 329 and 17-4 PH Grades of Stainless Steel, Silicone Nitride, Leather, acetal, PTFE, UHMWPE, Tungsten Carbide

Technical Data (Viscount Pump)



WARNING

Be sure that all fluids and solvents used are chemically compatible with the Wetted Parts listed below. Always read the manufacturer's literature before using fluid or solvent in this pump.

Category	Data
Maximum fluid working pressure	14.0 MPa, 138 bar (2000 psi)
Maximum oil input pressure	10.0 MPa, 103 bar (1500 psi)
Pump cycles per 3.8 liters (1 gal.)	6.5
Fluid flow at 60 cpm	34.9 liters/min (9.2 gpm)
Hydraulic motor piston effective area	31.6 cm ² (4.9 in. ²)
Stroke length	120 mm (4.75 in.)
Displacement pump effective area	24 cm ² (3.72 in. ²)
Maximum pump operating temperature	65.5° C (150° F)
Hydraulic oil supply size	3/4 npsm(f)
Hydraulic oil return size	1 in. npt
Fluid inlet size	2 in. npt(f)
Fluid outlet size	1-1/2 in. npt(m)
Weight	approx. 89 kg (196 lb)
Wetted parts	304, 329 and 17-4 PH Grades of Stainless Steel; Tungsten Carbide; acetal, PTFE, Ultra-High Molecular Weight Polyethylene

Technical Data (Viscount Pump)

Performance Charts: Viscount Pump

To find Fluid Outlet Pressure (psi/MPa/bar) at a specific fluid flow (lpm/gpm) and operating air pressure (psi/MPa/bar):

1. Locate desired flow along bottom of chart.
2. Follow vertical line up to intersection with selected fluid outlet pressure curve (black). Follow left to scale to read fluid outlet pressure.

To find Pump Air Consumption (m³/min or scfm) at a specific fluid flow (lpm/gpm) and hydraulic pressure (psi/MPa/bar):

1. Locate desired flow along bottom of chart.
2. Read vertical line up to intersection with selected hydraulic consumption curve (dashes). Follow left to scale to read oil consumption.

- A** 10.5 MPa, 105 bar (1500 psi) hydraulic oil pressure
- B** 7.5 MPa, 74 bar (1050 psi) hydraulic pressure
- C** 4.2 MPa, 42 bar (600 psi) hydraulic pressure

Test Fluid: No. 10 Weight Oil

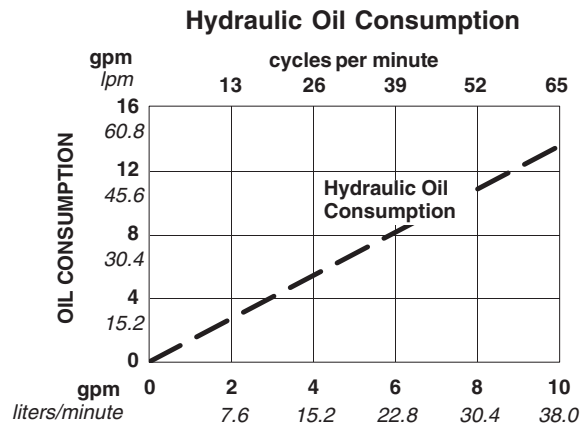
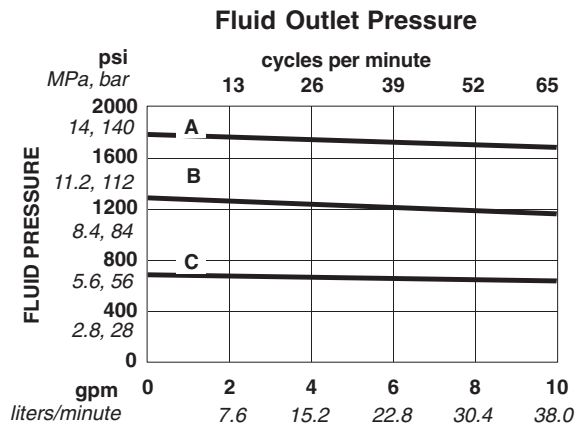

Dimensions

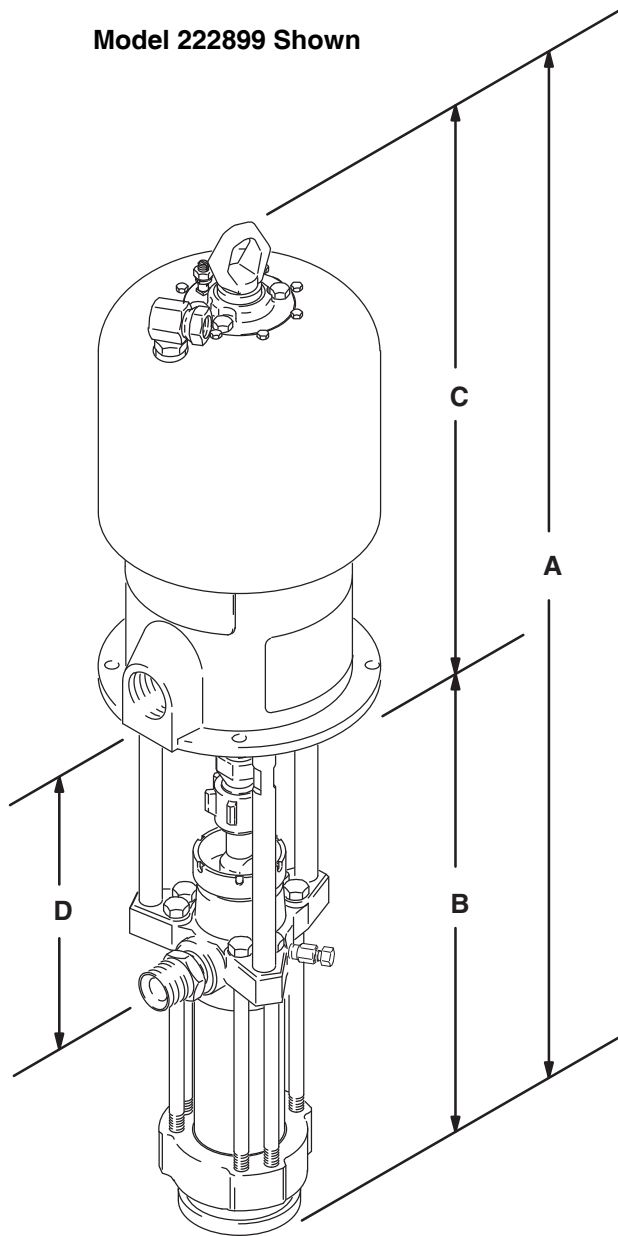

0566B

Pump Model	A	B	C	D
222827	1183 mm (46.58 in.)	642.6 mm (25.3 in.)	540.5 mm (21.28 in.)	298.0 mm (11.73 in.)
222899	1226 mm (48.25 in.)	642.6 mm (25.3 in.)	583.0 mm (22.95 in.)	298.0 mm (11.73 in.)
222898	1235 mm (48.63 in.)	642.6 mm (25.3 in.)	592.5 mm (23.33 in.)	298.0 mm (11.73 in.)
24Y192, 24Y206	1125.0 mm (44.3 in.)	759.0 mm (29.9 in.)	366.0 mm (14.41 in.)	413.0 mm (16.3 in.)
222900	1264.8 mm (49.8 in.)	642.6 mm (25.3 in.)	622.2 mm (24.5 in.)	298.0 mm (11.73 in.)

Mounting Hole Layouts

King, Bulldog, and Viscount Pumps

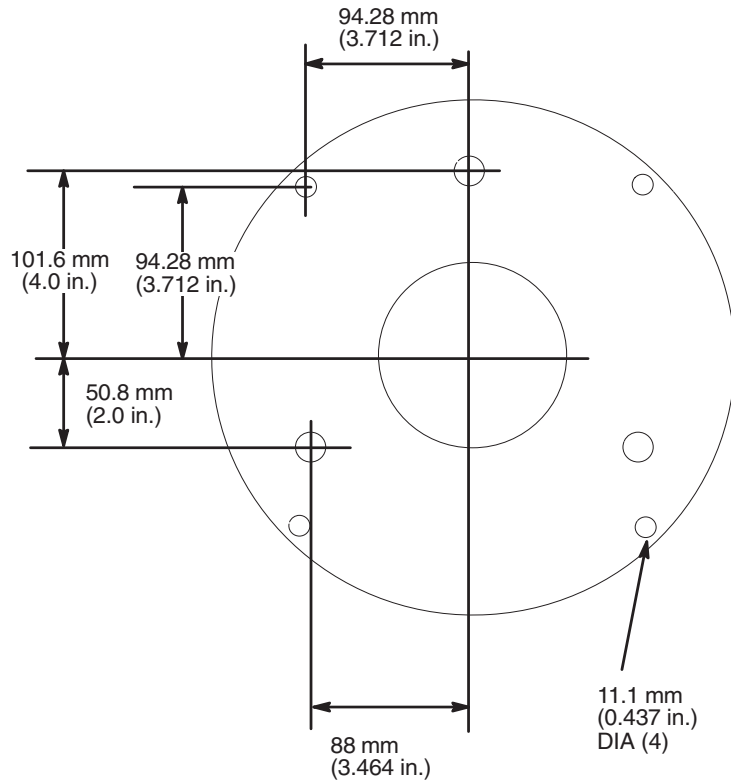

XL10000™ Pumps

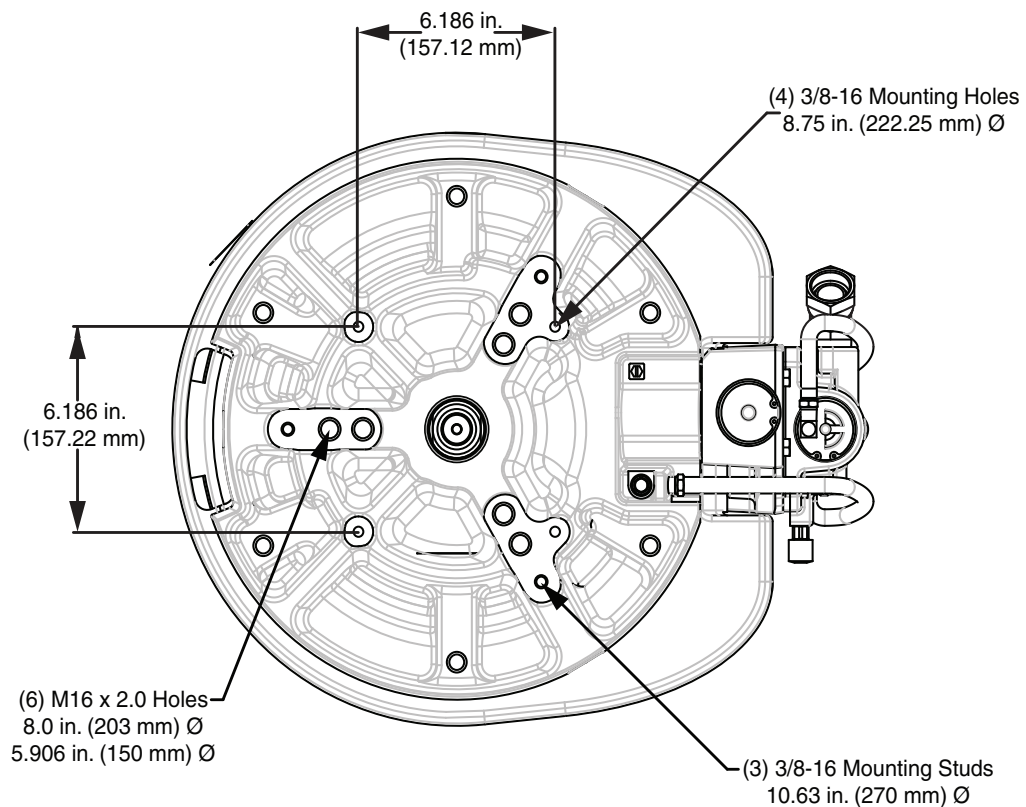

Graco Standard Warranty

Graco warrants all equipment manufactured by Graco and bearing its name to be free from defects in material and workmanship on the date of sale to the original purchaser for use. With the exception of any special, extended, or limited warranty published by Graco, Graco will, for a period of twelve months from the date of sale, repair or replace any part of the equipment determined by Graco to be defective. This warranty applies only when the equipment is installed, operated and maintained in accordance with Graco's written recommendations.

This warranty does not cover, and Graco shall not be liable for general wear and tear, or any malfunction, damage or wear caused by faulty installation, misapplication, abrasion, corrosion, inadequate or improper maintenance, negligence, accident, tampering, or substitution of non-Graco component parts. Nor shall Graco be liable for malfunction, damage or wear caused by the incompatibility of Graco equipment with structures, accessories, equipment or materials not supplied by Graco, or the improper design, manufacture, installation, operation or maintenance of structures, accessories, equipment or materials not supplied by Graco.

This warranty is conditioned upon the prepaid return of the equipment claimed to be defective to an authorized Graco distributor for verification of the claimed defect. If the claimed defect is verified, Graco will repair or replace free of charge any defective parts. The equipment will be returned to the original purchaser transportation prepaid. If inspection of the equipment does not disclose any defect in material or workmanship, repairs will be made at a reasonable charge, which charges may include the costs of parts, labor, and transportation.

THIS WARRANTY IS EXCLUSIVE, AND IS IN LIEU OF ANY OTHER WARRANTIES, EXPRESS OR IMPLIED, INCLUDING BUT NOT LIMITED TO WARRANTY OF MERCHANTABILITY OR WARRANTY OF FITNESS FOR A PARTICULAR PURPOSE.

Graco's sole obligation and buyer's sole remedy for any breach of warranty shall be as set forth above. The buyer agrees that no other remedy (including, but not limited to, incidental or consequential damages for lost profits, lost sales, injury to person or property, or any other incidental or consequential loss) shall be available. Any action for breach of warranty must be brought within two (2) years of the date of sale.

Graco makes no warranty, and disclaims all implied warranties of merchantability and fitness for a particular purpose in connection with accessories, equipment, materials or components sold but not manufactured by Graco. These items sold, but not manufactured by Graco (such as electric motors, switches, hose, etc.), are subject to the warranty, if any, of their manufacturer. Graco will provide purchaser with reasonable assistance in making any claim for breach of these warranties.

In no event will Graco be liable for indirect, incidental, special or consequential damages resulting from Graco supplying equipment hereunder, or the furnishing, performance, or use of any products or other goods sold hereto, whether due to a breach of contract, breach of warranty, the negligence of Graco, or otherwise.

FOR GRACO CANADA CUSTOMERS

The parties acknowledge that they have required that the present document, as well as all documents, notices and legal proceedings entered into, given or instituted pursuant hereto or relating directly or indirectly hereto, be drawn up in English. Les parties reconnaissent avoir convenu que la rédaction du présente document sera en Anglais, ainsi que tous documents, avis et procédures judiciaires exécutés, donnés ou intentés à la suite de ou en rapport, directement ou indirectement, avec les procédures concernées.

Graco Information

For the latest information about Graco products, visit www.graco.com.

For patent information, see www.graco.com/patents.

TO PLACE AN ORDER, contact your Graco distributor or call to identify the nearest distributor.

Phone: 612-623-6921 or Toll Free: 1-800-328-0211 Fax: 612-378-3505

*All written and visual data contained in this document reflects the latest product information available at the time of publication.
Graco reserves the right to make changes at any time without notice.*

This manual contains English. MM 308152

Graco Headquarters: Minneapolis
International Offices: Belgium, China, Japan, Korea

GRACO INC. P.O. BOX 1441 MINNEAPOLIS, MN 55440-1441

Copyright 1995, Graco Inc. is registered to I.S. EN ISO 9001

www.graco.com

Revision ZAA, October 2015