

# Portable Evacuation System

308035H

EN

**For gear lube\*, gear lube evac or drain plug evac use. For professional use only.**

## Model 223695

For gear lube use only\*. Includes a special Husky™ 716 diaphragm pump, a mounting frame that allows the pump to hang on the back of a rolling drain cart and discharge fluid directly into the cart, and a suction wand kit.

\*To adapt for use with antifreeze and automatic transmission fluid, order option Suction Kit 223888.

*100 psi (0.7 MPa, 7 bar) Maximum Working Pressure  
40 to 50 psi (0.28 to 0.34 MPa, 2.8 to 3.4 bar)  
Recommended operating pressure*

## Model 235335

For gear lube evac or drain plug evac. Includes a Husky™ 716 diaphragm pump, a mounting frame that allows the pump to hang on the back of a rolling drain cart and discharge fluid directly into the cart, a suction wand kit, and a drain plug adapter kit.

*100 psi (0.7 MPa, 7 bar) Maximum Working Pressure  
40 to 50 psi (0.28 to 0.34 MPa, 2.8 to 3.4 bar)  
Recommended operating pressure*



### Important Safety Instructions

Read all warnings and instructions in this manual. Save these instructions.

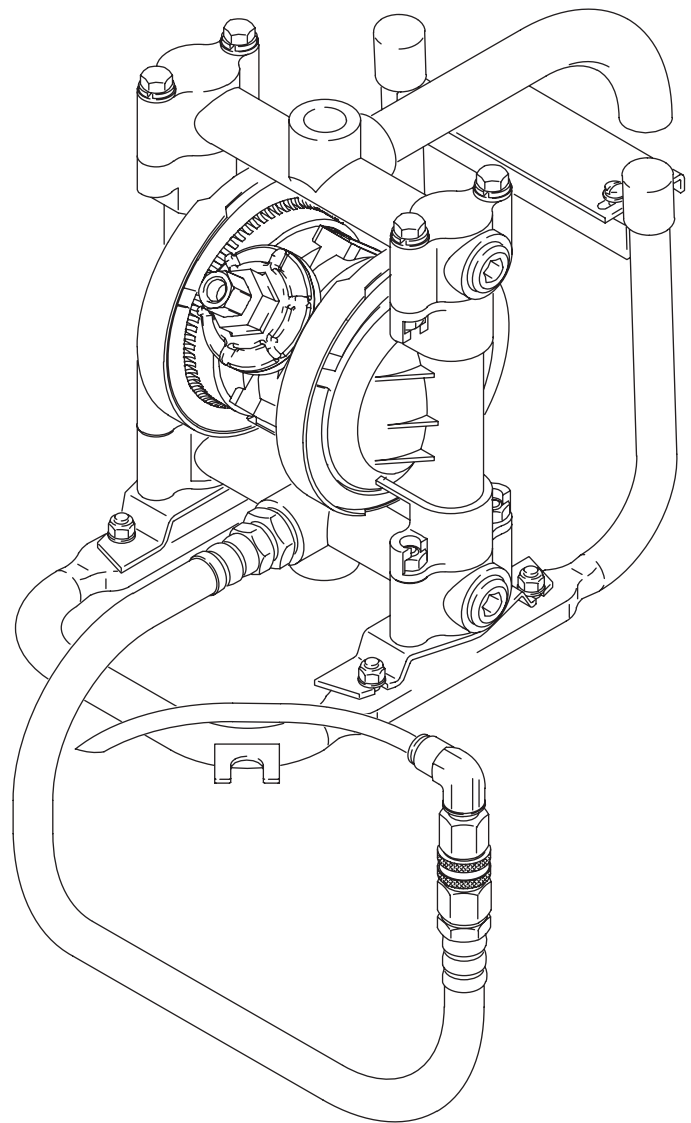

# Warnings

The following warnings are for the setup, use, grounding, maintenance, and repair of this equipment. The exclamation point symbol alerts you to a general warning and the hazard symbols refer to procedure-specific risks. When these symbols appear in the body of this manual or on warning labels, refer back to these Warnings. Product-specific hazard symbols and warnings not covered in this section may appear throughout the body of this manual where applicable.



## WARNING







### FIRE AND EXPLOSION HAZARD

When flammable fluids are present in the work area, such as gasoline and windshield wiper fluid, be aware that flammable fumes can ignite or explode. To help prevent fire and explosion:

- Use equipment only in well ventilated area.
- Eliminate all ignition sources, such as cigarettes and portable electric lamps.
- Keep work area free of debris, including rags and spilled or open containers of solvent and gasoline.
- Do not plug or unplug power cords or turn lights on or off when flammable fumes are present.
- Ground all equipment in the work area.
- Use only grounded hoses.
- **Stop operation immediately** if static sparking occurs or you feel a shock. Do not use equipment until you identify and correct the problem.
- Keep a working fire extinguisher in the work area.

# Installation

## Grounding

						
<p>The equipment must be grounded to reduce the risk of static sparking and electric shock. Electric or static sparking can cause fumes to ignite or explode. Improper grounding can cause electric shock. Grounding provides an escape wire for the electric current.</p>						

**Pump:** Attach ground wire (Y) to the grounding strip (107) with the screw (117), lockwasher (118) and nut (119), as shown in FIG. 1. Connect the clamp end of a ground wire to a true earth ground. To order a ground wire and clamp, order Part No. 222011.

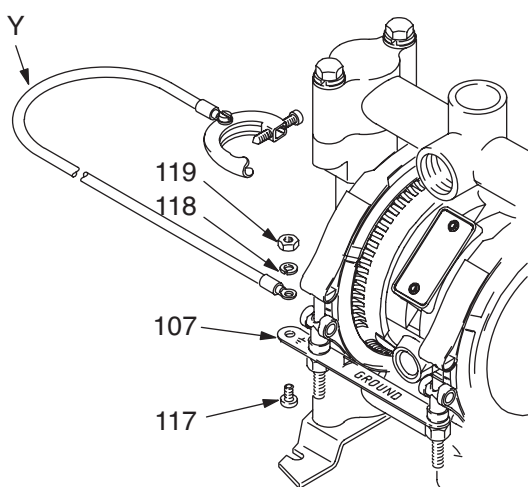

FIG. 1

**Air and fluid hoses:** Use only electrically conductive hoses.

**Air compressor:** Follow manufacturer's recommendations.

**Fluid supply container:** Follow local code.

**Solvent pails used when flushing:** Follow local code. Use only grounded metal pails, which are conductive. Do not place the pail on a non-conductive surface, such as paper or cardboard, which interrupts the grounding continuity.

# Installing

1. Install the parts as shown. Apply sealant to all male pipe threads.
2. Ground the pump.
3. Connect the air supply hose to the male quick coupler.
4. Hang the pump assembly over the back of a rolling drain cart. Adjust the sliding hanger so the hanger fit snugly against the rolling drain cart, and tighten the screw.
5. Connect a suction wand or the 45° swivel to the suction hose.

**NOTE:** When using a suction wand, always use the largest wand that will fit into the differential.

## Setup for Gear Lube Evacuation

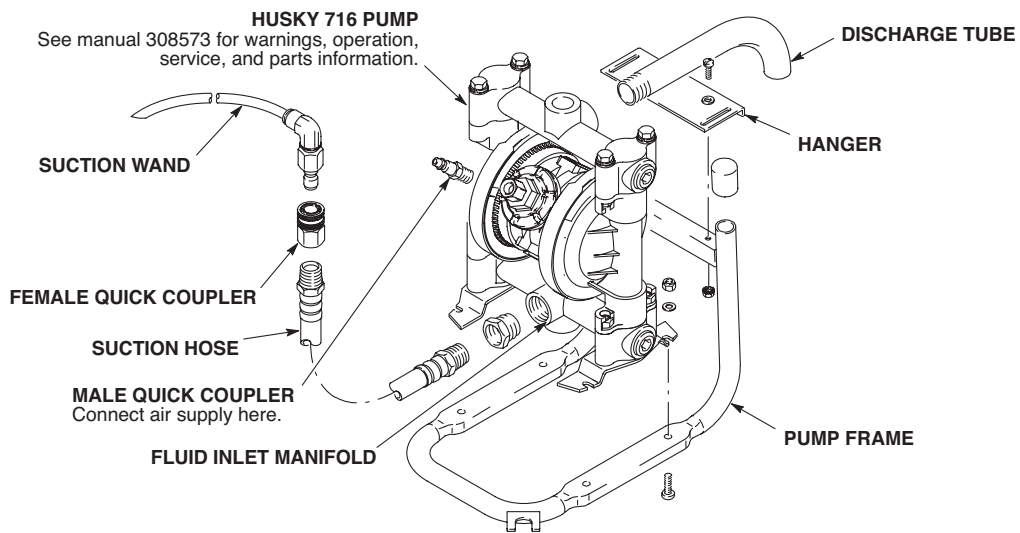

## Setup for Drain Plug Evacuation

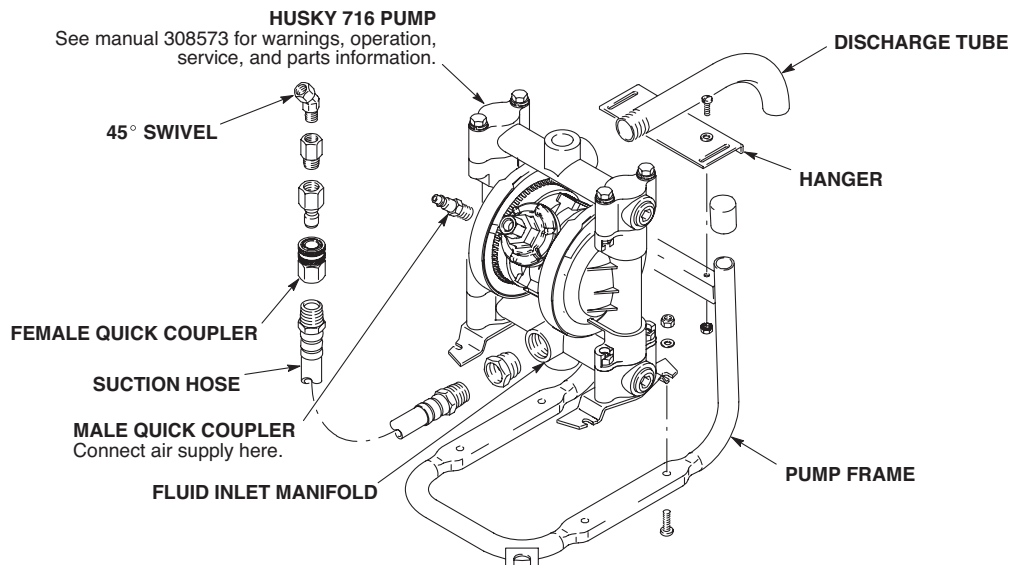
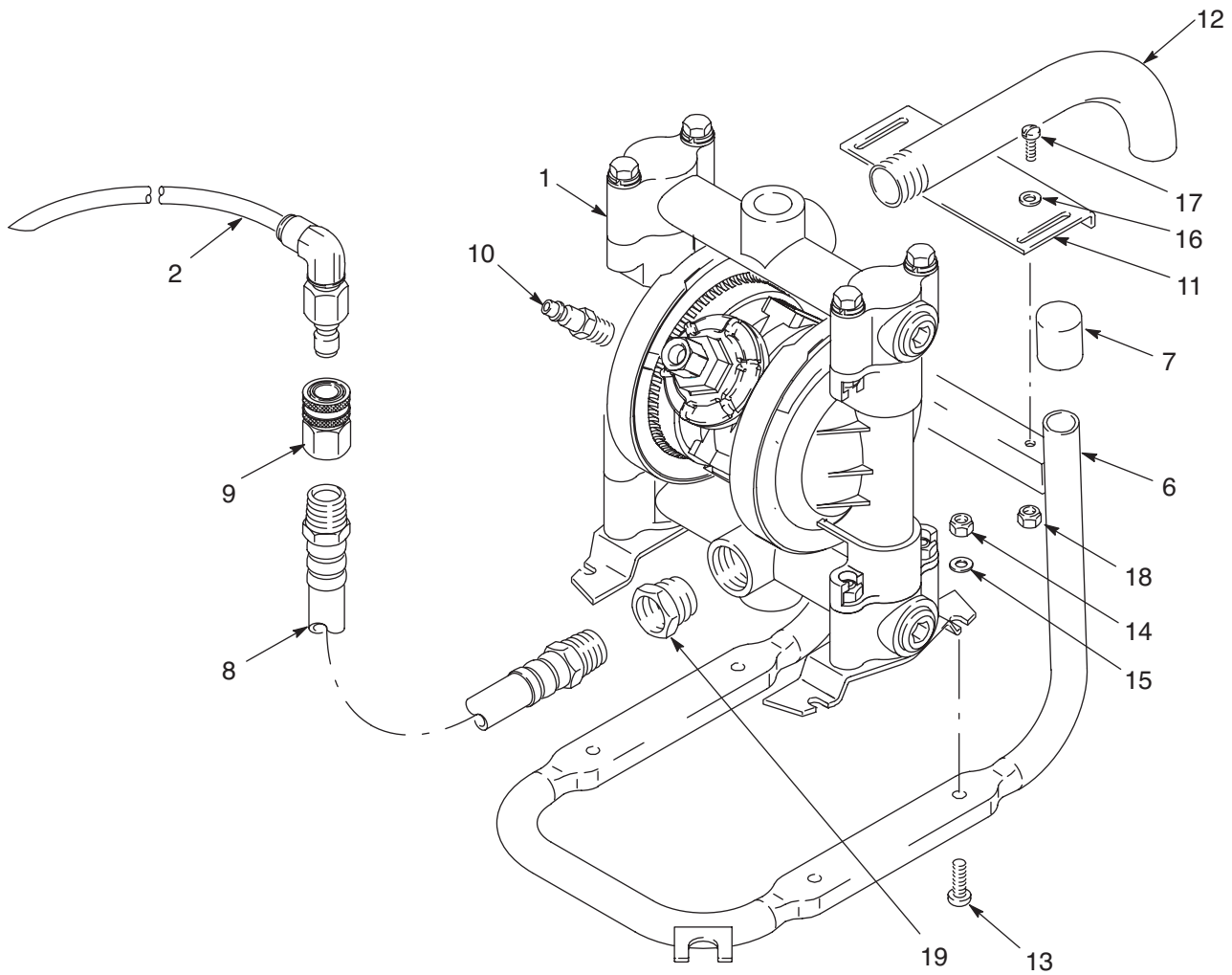

FIG. 2:

## Operation

- Set the air pressure to 40 to 50 psi (0.28 to 0.34 MPa, 2.8 to 3.4 bar) for the best results. Connect the air supply hose to the male quick coupler. Disconnect the air supply hose when the evacuation is complete.
- To use the pump for draining anti-freeze or ATF, use optional Suction Kit 223888. Connect the kit to the fluid inlet manifold.

# Parts



## Gear Lube Evacuation System, Model 223695

Ref.	Part	Description	Qty.
1	241906	PUMP, diaphragm, Husky 716, see manual 308573	1

## Suction Wand Kit, 223696

Ref.	Part	Description	Qty.
2	221145	WAND, 1/2"	1
3	222025	WAND, 3/16", not shown	1
4	222024	WAND, 1/4", not shown	1
5	221144	WAND, 3/8", not shown	1

## Mounting Kit, 223697

Ref.	Part	Description	Qty.
6	223694	FRAME	1
7	110821	CAP	2
8	111473	HOSE	1
9	801569	QUICK COUPLER (F)	1
10	169970	QUICK DISCONNECT, air	1
11	186309	BRACKET, adjustable	1
12	186312	TUBE, discharge	1
13	110823	SCREW	4
14	102040	NUT, nylock	4
15	158223	WASHER	4
16	108193	WASHER	2
17	100036	SCREW	2
18	113505	NUT	2
19	100896	BUSHING	1

### Drain Plug or Gear Lube Evacuation System, Model 235335

Ref.	Part	Description	Qty.
1	241906	PUMP, diaphragm, Husky 716, see manual 308573	1

### Suction Wand Kit, 223696

Ref.	Part	Description	Qty.
2	221145	WAND, 1/2"	1
3	222025	WAND, 3/16", not shown	1
4	222024	WAND, 1/4", not shown	1
5	221144	WAND, 3/8", not shown	1

### Mounting Kit, 223697

Ref.	Part	Description	Qty.
6	223694	FRAME	1
7	110821	CAP	2
8	111473	HOSE	1
9	801569	QUICK COUPLER (F)	1
10	169970	QUICK DISCONNECT, air	1

Ref.	Part	Description	Qty.
11	186309	BRACKET, adjustable	1
12	186312	TUBE, discharge	1
13	110823	SCREW	4
14	102040	NUT, nylock	4
15	158223	WASHER	4
16	108193	WASHER	2
17	100036	SCREW	2
18	113505	NUT	2
19	100896	BUSHING	1

### Adapter Kit, 235334

Ref.	Part	Description	Qty.
20	801568	QUICK COUPLER (M)	1
21	159841	BUSHING	1
22	160127	SWIVEL, 45°	1

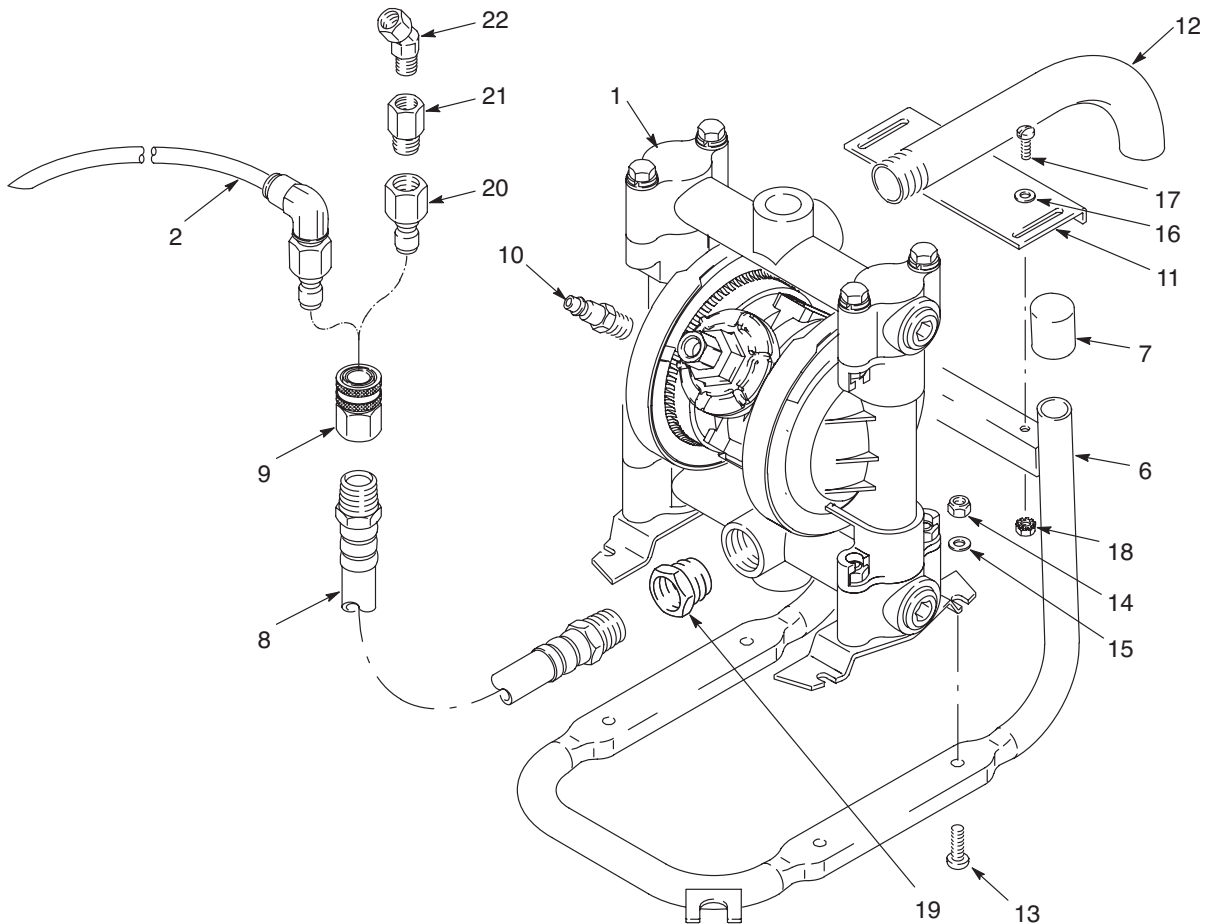

# Graco Standard Warranty

Graco warrants all equipment referenced in this document which is manufactured by Graco and bearing its name to be free from defects in material and workmanship on the date of sale to the original purchaser for use. With the exception of any special, extended, or limited warranty published by Graco, Graco will, for a period of twelve months from the date of sale, repair or replace any part of the equipment determined by Graco to be defective. This warranty applies only when the equipment is installed, operated and maintained in accordance with Graco's written recommendations.

This warranty does not cover, and Graco shall not be liable for general wear and tear, or any malfunction, damage or wear caused by faulty installation, misapplication, abrasion, corrosion, inadequate or improper maintenance, negligence, accident, tampering, or substitution of non-Graco component parts. Nor shall Graco be liable for malfunction, damage or wear caused by the incompatibility of Graco equipment with structures, accessories, equipment or materials not supplied by Graco, or the improper design, manufacture, installation, operation or maintenance of structures, accessories, equipment or materials not supplied by Graco.

This warranty is conditioned upon the prepaid return of the equipment claimed to be defective to an authorized Graco distributor for verification of the claimed defect. If the claimed defect is verified, Graco will repair or replace free of charge any defective parts. The equipment will be returned to the original purchaser transportation prepaid. If inspection of the equipment does not disclose any defect in material or workmanship, repairs will be made at a reasonable charge, which charges may include the costs of parts, labor, and transportation.

**THIS WARRANTY IS EXCLUSIVE, AND IS IN LIEU OF ANY OTHER WARRANTIES, EXPRESS OR IMPLIED, INCLUDING BUT NOT LIMITED TO WARRANTY OF MERCHANTABILITY OR WARRANTY OF FITNESS FOR A PARTICULAR PURPOSE.**

Graco's sole obligation and buyer's sole remedy for any breach of warranty shall be as set forth above. The buyer agrees that no other remedy (including, but not limited to, incidental or consequential damages for lost profits, lost sales, injury to person or property, or any other incidental or consequential loss) shall be available. Any action for breach of warranty must be brought within two (2) years of the date of sale.

**GRACO MAKES NO WARRANTY, AND DISCLAIMS ALL IMPLIED WARRANTIES OF MERCHANTABILITY AND FITNESS FOR A PARTICULAR PURPOSE, IN CONNECTION WITH ACCESSORIES, EQUIPMENT, MATERIALS OR COMPONENTS SOLD BUT NOT MANUFACTURED BY GRACO.** These items sold, but not manufactured by Graco (such as electric motors, switches, hose, etc.), are subject to the warranty, if any, of their manufacturer. Graco will provide purchaser with reasonable assistance in making any claim for breach of these warranties.

In no event will Graco be liable for indirect, incidental, special or consequential damages resulting from Graco supplying equipment hereunder, or the furnishing, performance, or use of any products or other goods sold hereto, whether due to a breach of contract, breach of warranty, the negligence of Graco, or otherwise.

## **FOR GRACO CANADA CUSTOMERS**

The Parties acknowledge that they have required that the present document, as well as all documents, notices and legal proceedings entered into, given or instituted pursuant hereto or relating directly or indirectly hereto, be drawn up in English. Les parties reconnaissent avoir convenu que la rédaction du présente document sera en Anglais, ainsi que tous documents, avis et procédures judiciaires exécutés, donnés ou intentés, à la suite de ou en rapport, directement ou indirectement, avec les procédures concernées.

# Graco Information

For the latest information about Graco products, visit [www.graco.com](http://www.graco.com).

**TO PLACE AN ORDER**, contact your Graco distributor or call to identify the nearest distributor.

**Phone:** 612-623-6928 or **Toll Free:** 1-800-533-9655, **Fax:** 612-378-3590.

*All written and visual data contained in this document reflects the latest product information available at the time of publication.  
Graco reserves the right to make changes at any time without notice.*

*For patent information, see [www.graco.com/patents](http://www.graco.com/patents).*

Original instructions. This manual contains English. MM 308035

**Graco Headquarters:** Minneapolis  
**International Offices:** Belgium, China, Japan, Korea

**GRACO INC. AND SUBSIDIARIES • P.O. BOX 1441 • MINNEAPOLIS MN 55440-1441 • USA**

**Copyright 1989, Graco Inc. All Graco manufacturing locations are registered to ISO 9001.**

[www.graco.com](http://www.graco.com)

Revised January 2013