

Instructions – Parts List



FIRE-BALL 300® and FIRE-BALL 425® DRUM or TANK SUPPLY PUMPS 306520J

Used to pump petroleum and synthetic based oils.

5:1 Fire-Ball 300 Pump Model 225852

900 psi (60 bar) Maximum Working Pressure

10:1 Fire-Ball 425 Pump Model 225853

1800 psi (120 bar) Maximum Working Pressure



Important Safety Instructions.

Read all warnings and instructions in this manual.
Save these instructions.

Table of Contents

Warnings	2
Installation	4
Operation	8
Parts Drawing	9
Parts Lists	9
Warranty	10
Graco Phone Number	10

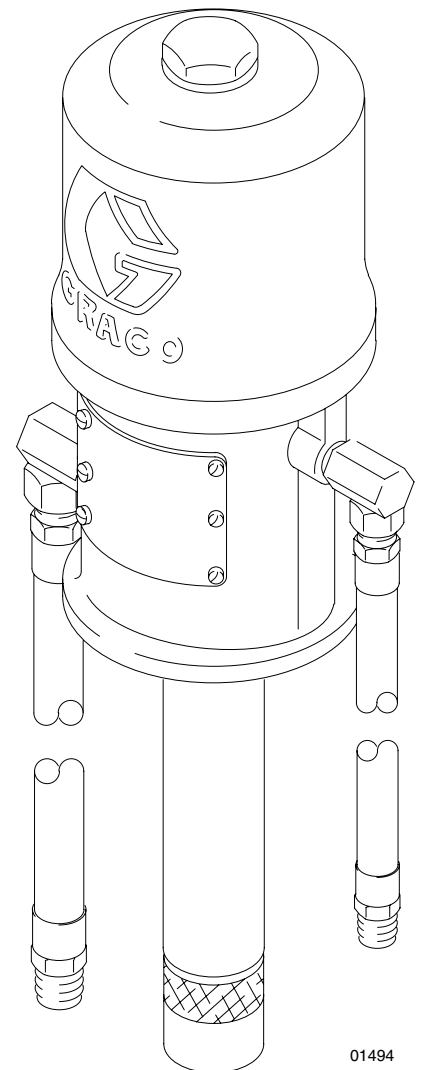

Model 225852 Fire-Ball 300 shown

PROVEN QUALITY. LEADING TECHNOLOGY.



Symbols

Warning Symbol



This symbol alerts you to the possibility of serious injury or death if you do not follow the instructions.

Caution Symbol



This symbol alerts you to the possibility of damage to or destruction of equipment if you do not follow the instructions.

WARNING



INSTRUCTIONS

EQUIPMENT MISUSE HAZARD

Equipment misuse can cause the equipment to rupture or malfunction and result in serious injury.

- This equipment is for professional use only.
- Read all instruction manuals, tags, and labels before operating the equipment.
- Use the equipment only for its intended purpose. If you are not sure, call your Graco distributor.
- Do not alter or modify this equipment.
- Check equipment daily. Repair or replace worn or damaged parts immediately.
- Do not exceed the maximum working pressure stated on the equipment or in the **Technical Data** for your equipment. Do not exceed the maximum working pressure of the lowest rated component in your system.
- Use fluids and solvents that are compatible with the equipment wetted parts. Refer to the **Technical Data** section of all equipment manuals. Read the fluid and solvent manufacturer's warnings.
- Handle hoses carefully. Do not pull on hoses to move equipment.
- **All fluid hoses must have spring guards on both ends.** The spring guards help protect the hose from kinks or bends at or close to the coupling, which can result in hose rupture.
- Route hoses away from traffic areas, sharp edges, moving parts, and hot surfaces. Do not expose Graco hoses to temperatures above 82°C (180°F) or below -40°C (-40°F).
- Do not lift pressurized equipment.
- Comply with all applicable local, state, and national fire, electrical, and safety regulations.
- Use only dispensing valves that are designed to dispense motor oil. Do not modify any part of the dispensing valve; doing so could cause a malfunction and result in serious bodily injury. Be sure the dispensing valve has a maximum working pressure that meets or exceeds that of the pump.
- The maximum fluid working pressure of these pumps, when operated at a maximum of 180 psi (12.6 bar) air pressure is **900 psi (60 bar) on the 5:1 Fire-Ball 300 Pump, and it is 1800 psi (120 bar) on the 10:1 Fire-Ball 425 Pump.**



WARNING



SKIN INJECTION HAZARD

Fluid from the dispensing valve, leaks, or ruptured components can inject fluid into your body and cause extremely serious injury, including the need for amputation. Fluid splashed in the eyes or on the skin can also cause serious injury.

- Fluid injected into the skin may look like just a cut, but it is a serious injury. **Get immediate surgical treatment.**
- Do not point the dispensing valve at anyone or at any part of the body.
- Do not put your hand or fingers over the end of the dispensing valve.
- Do not stop or deflect leaks with your hand, body, glove, or rag.
- Use only extensions and tips that are designed for use with your dispensing valve.
- Tighten all fluid connections before operating the equipment.
- Check the hoses, tubes, and couplings daily. Replace worn or damaged parts immediately. Do not repair high pressure couplings; you must replace the entire hose.



HAZARDOUS FLUIDS

Improper handling of hazardous fluids or inhaling toxic fumes can cause extremely serious injury or death due to splashing in the eyes, ingestion, or bodily contamination.

- Know the specific hazards of the fluid you are using.
- Store hazardous fluid in an approved container. Dispose of hazardous fluid according to all local, state, and national guidelines.
- Always wear protective eyewear, gloves, clothing, and respirator as recommended by the fluid and solvent manufacturer.

WARNING



FIRE AND EXPLOSION HAZARD

Improper grounding, poor ventilation, open flames, or sparks can cause a hazardous condition and result in a fire or explosion and serious injury.

- Ground the equipment. Refer to **Grounding** below.
- If there is any static sparking or you feel an electric shock while using this equipment, **stop dispensing immediately**. Do not use the equipment until you identify and correct the problem.
- Provide fresh air ventilation to avoid the buildup of flammable fumes from solvents or the fluid being dispensed.
- Do not smoke in the dispensing area.



MOVING PARTS HAZARD

Moving parts can pinch or amputate your fingers.

- Keep clear of all moving parts when starting or operating the pump.
- Before servicing the equipment, follow the **Pressure Relief Procedure** on page 8 to prevent the equipment from starting unexpectedly.

United States Government safety standards have been adopted under the Occupational Safety and Health Act. You should consult these standards—particularly General Standards, Part 1910, and Construction Standards, Part 1926.

Installation

Grounding

To reduce the risk of static sparking, ground the pump. Check your local electrical code for detailed grounding instructions for your area and type of equipment.

- **Pump:** Use ground wire and clamp as shown in Fig. 1.
- **Air and fluid hoses:** Use only electrically conductive hoses.
- **Air compressor:** Follow manufacturer's recommendations.
- **Dispensing valve:** Obtain grounding through connection to a properly grounded fluid hose and pump.
- **Fluid supply container:** Follow your local code.
- **Object being lubricated:** Follow your local code.
- **Any pails used when flushing:** Use only metal, grounded pails when flushing. Make firm metal-to-metal contact between a metal part of the dispensing valve and the pail. Use the lowest possible pressure.

- *To maintain grounding continuity when flushing or relieving pressure, always hold a metal part of the dispensing valve firmly to the side of a metal pail, and then open the dispensing valve.*

To ground the pump:

To ground the pump, use a ground wire and clamp as shown below. Remove the ground screw (Z) and insert through the eye of ring terminal at end of ground wire (Y). Fasten the ground screw back onto the pump and tighten securely. Connect the other end of the ground wire to a true earth ground. See Fig. 1. *To order a ground wire and clamp, order Part No. 222011.*

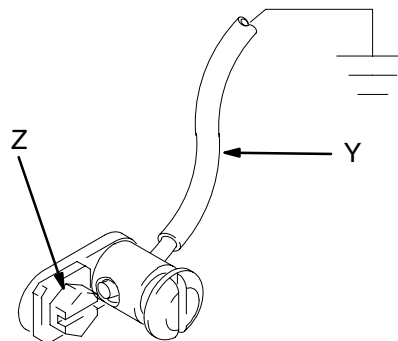

Fig. 1

TI1052

Installation

The typical installation shown in Fig. 2 is only an installation guide; it is not an actual system design. Contact your Graco distributor for assistance in designing a system to suit your needs.

- | | | |
|--|---|---|
| A Maximum vertical lift, tank foot valve to pump intake valve: 10 ft. (3 m) | E Pipe: 1.5 or 2 in. standard iron | K Fill cap |
| B Suction line at pump: 9 in. (230 mm) from wall | F Horizontal suction line: 75 ft. (23 m) maximum | L 4 in. (102 mm) standard pipe |
| C Suction line at pump: 6 in. (150 mm) above floor | G Stub assembly | M Extractor fitting |
| D Vent pipe | H O.P.W. – Buckeye or equivalent extractable suction | N 4 in. (102 mm) from bottom of tank |
| | J Manhole cover | P 1.5 in. foot valve |
| | | Q Swing joints |
| | | R Gate valve |

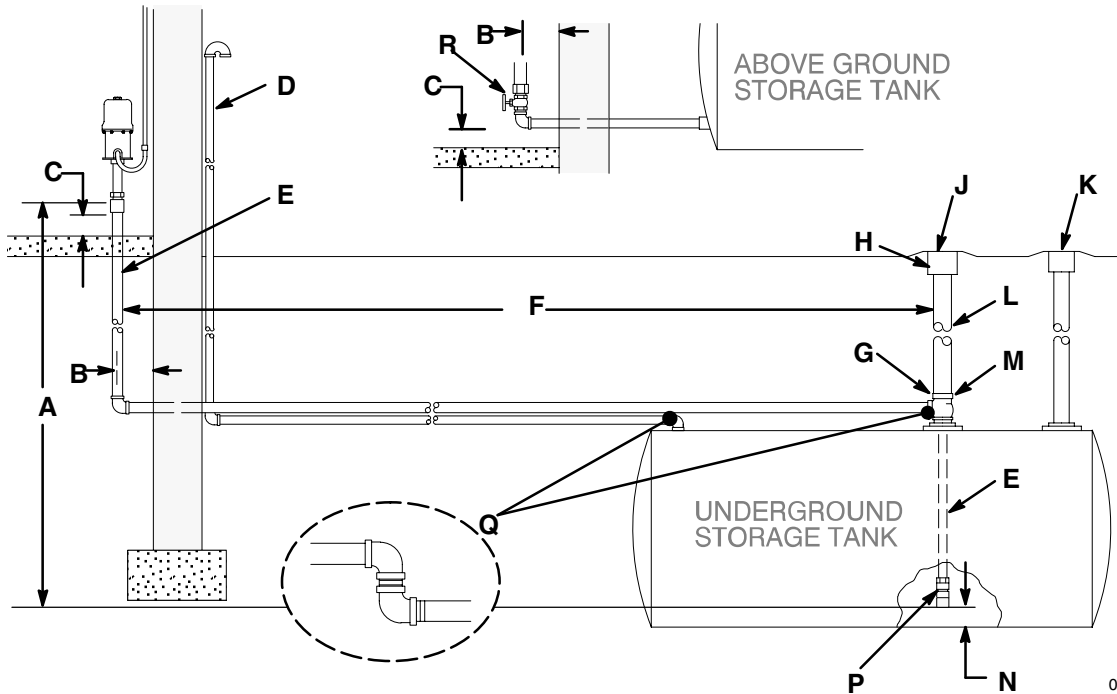

Fig. 2

01495

Permanent Supply and Suction Lines

- Install pumps as close to the tanks as practical.
- Use 1.5 or 2 in. (38 mm or 50 mm) standard iron pipe and heavy malleable iron fittings. Ream the ends of iron pipe and use thread sealant for an airtight system.
- Use long sweeping bends for turns in piping; avoid unnecessary turns.
- All tube ends must be clean and free of burrs. Ream the ends of iron pipe.
- Minimize the use of fittings.
- Avoid using unions and other connections underground and in hard to reach places.
- For underground tanks, blow out and clean all lines before installing them. Start the connections at the storage tank end.

- Flush and test the lines under pressure before covering or cementing in place.
- For installation dimensions for suction lines at the pump end, see Fig. 3.

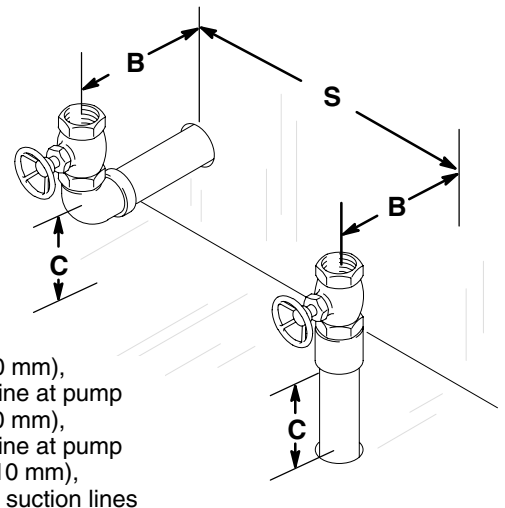

- B** 9 in. (230 mm), Suction line at pump
- C** 6 in. (150 mm), Suction line at pump
- S** 20 in. (510 mm), Between suction lines

Fig. 3

01496

Installation

Supply Lines From Pumps To Dispensing Units

Distance	Annealed Steel Tube			Annealed Copper Tube			Standard Iron Pipe	
	Min. O.D.	Min. Tube Wall	Fittings	Min. O.D.	Min. Tube Wall	Fittings	Min. Size	Fittings
< 25 ft. (7.6 m)	5/8 in.	0.035 in. (0.89)	Flareless	5/8 in. type K	0.049 in. (1.24 mm)	Flared	1/2 in.	Heavy malleable iron
> 25 ft. (7.6 m)	7/8 in.	0.035 in. (0.89)	Flareless	7/8 in. type K	0.065 in. (1.65 mm)	Flared	3/4 in.	Heavy malleable iron
> 75 ft. (23 m)	Contact your Graco distributor							

- A Incoming supply line
- B 3/4 in. npt line strainer
- C Hose or pipe to metered unit
- D Position outlet down

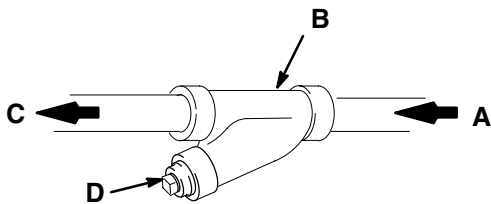

Fig. 4

1. Use a Y-type line strainer in oil supply lines. Locate as close to the meter inlets as practical and where they are easily accessible. Mount the strainer body horizontally with the clean-out plug pointed down. See Fig. 4. Periodically, **relieve the pressure**, and remove and clean the metal strainers.

To order a 3/4 in. npt(f) line strainer, order Part No. 101078.

To order a 1/2 in. npt(f) line strainer, order Part No. 110877.

⚠ WARNING

INJECTION HAZARD
To reduce the risk of serious injury whenever you are instructed to relieve pressure, always follow the **Pressure Relief Procedure** on page 8.



2. See Fig. 5 for installation dimensions for the supply line. Space the line ends to be adjacent to the pump location. For annealed steel or copper tubing lines, use a straight male coupling elbow and a shutoff valve. For iron pipe, a shutoff valve may be used instead. The shutoff valve must close off 1/2 in. npt(f) openings for the Fire-Ball 300 pump, and it must close off 3/4 in. npt(f) openings for the Fire-Ball 425 pump.

Air Lines

Air lines	Annealed Copper Tube		Galvanized Pipe
	O.D. Type L	Minimum Wall Thickness	
Pump to main air	1/2 or 3/8 in.	0.035 in. (0.89 mm)	1/2 in. or 3/8 in.
Compressor to main air	1/2 in.	0.035 in. (0.89 mm)	1/2 in. or 3/8 in.

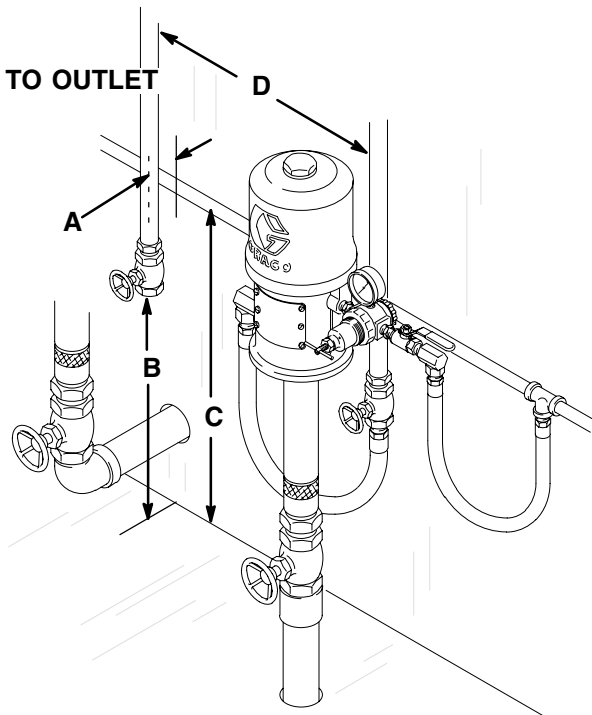

- A 3 in. (76 mm), Supply line to wall
- B 20 in. (510 mm), Main fluid shutoff valves
- C 24 in. (610 mm), Main air line to floor
- D 20 in. (510 mm), Between suction lines

Fig. 5

01497

Installation

Air and Fluid Line Accessories

CAUTION

Do not hang the air accessories directly on the air inlet. Mount them on brackets. The fittings are not strong enough to support the accessories and may break.

- Use thread sealant on male threads except at swivel connections.
- Install a bleed-type master air valve upstream from the pump air regulator, but within easy reach of the pump.

To order a 300 psi (21 bar) maximum working pressure, 1/2 in. npt bleed-type master air valve, order Part No. 107142.

WARNING

A bleed-type master air valve is required in the system to help reduce the risk of serious bodily injury, including fluid injection, splashing in the eyes, and injury from moving parts when adjusting or repairing the pump. This valve relieves air trapped between the valve and the pump to prevent the pump from cycling unexpectedly.

- Install the pump end of the air supply lines about 24 in. (610 mm) above the floor.
- If you are installing several pumps, put tees in the supply line immediately above and behind the pump locations. See Fig. 5.

- Install an air line lubricator for automatic air motor lubrication.

To order a 250 psi (17.5 bar) maximum working pressure air line lubricator, order a Part No. below:

3/8 in. npt 214847

1/2 in. npt 214848

- Install an air regulator to control pump speed and pressure.

To order a 300 psi (21 bar) maximum working pressure regulator, order a Part No. below:

3/8 in. npt 109075

1/2 in. npt 104266

- Install an air line filter to remove harmful dirt and contaminants from your compressed air supply.

To order a 250 psi (17.5 bar) maximum working pressure air filter, order a Part No. below:

3/8 in. npt 106148

1/2 in. npt 214849

- Install a thermal relief kit on the dispensing valve side of the pump to assist in relieving pressure in the pump, hose, and dispensing valve due to heat expansion.

To order a thermal relief kit for the Fire-Ball 300 pump—900 psi (62 bar) maximum working pressure—order Part No. 237893.

To order a thermal relief kit for the Fire-Ball 425 pump—1600 psi (110 bar) maximum working pressure—order Part No. 248324.

Operation

Pressure Relief Procedure

WARNING



INJECTION HAZARD

To reduce the risk of serious bodily injury, including fluid injection, injury from moving parts, or splashing in the eyes or on the skin, always follow this procedure whenever you shut off the pump, when checking or servicing any part of the system, when installing or changing dispensing devices, and whenever you stop dispensing.

1. Close the air regulator and disconnect the air supply hose.
2. Close the pump's bleed-type master air valve (required in the system).
3. Open the dispensing valve until pressure is fully relieved.

*If you suspect that the dispensing valve is clogged, or that pressure has not been fully relieved after following the steps above, **very slowly** loosen the dispensing valve coupler or hose end coupling to relieve pressure gradually, then loosen completely.*

Flushing

To reduce the risk of fluid injection injury, static sparking, or splashing, relieve pressure, hold a metal part of the dispensing valve firmly to the side of a grounded metal pail and use the lowest possible fluid pressure during flushing.

1. Before connecting the supply lines to the supply tank, flush the pump and supply line with a compatible solvent.
2. Connect the supply line to a solvent supply. Turn on the main air, open the bleed-type master air valve, and slowly open the pump air regulator until the pump is cycling slowly. Use the lowest possible pressure, and flush until the lines are thoroughly cleaned. Shut off the pump, and **relieve the pressure**.

WARNING



INJECTION HAZARD

To reduce the risk of serious injury whenever you are instructed to relieve pressure, always follow the **Pressure Relief Procedure** above.

3. Disconnect the solvent supply, and connect the supply lines to the tank.
4. Connect the fluid supply hose from the pump to the dispensing valve.

Operating

WARNING

Never exceed 180 psi (12.6 bar) Maximum Air Pressure to these pumps. Using higher air pressure will cause the pump to overpressurize, which may result in component rupture, fire, or explosion and cause serious bodily injury.

1. Open the bleed-type master air valve.
2. Slowly open the pump air regulator until the pump is running smoothly.
3. Open the dispensing valve, and allow the system to prime. When the system is fully primed, the pump starts and stops as the dispensing valve is opened and closed.

CAUTION

Never allow the pump to run dry of the fluid being pumped. A dry pump will quickly accelerate to a high speed and possibly damage itself. If the pump accelerates quickly, stop it immediately, and check the fluid supply. If the supply container is empty and air has been pumped into the lines, prime the pump and lines with fluid, or flush it and leave it filled with a compatible solvent. Be sure to eliminate all air from the fluid system.

4. Use the air regulator to control pump speed and fluid pressure. Always use the lowest possible pressure, which reduces pump wear.
5. When shutting off the system, and before checking or servicing it, **relieve the pressure**.

WARNING



INJECTION HAZARD

To reduce the risk of serious injury whenever you are instructed to relieve pressure, always follow the **Pressure Relief Procedure** at left.

Parts Drawing

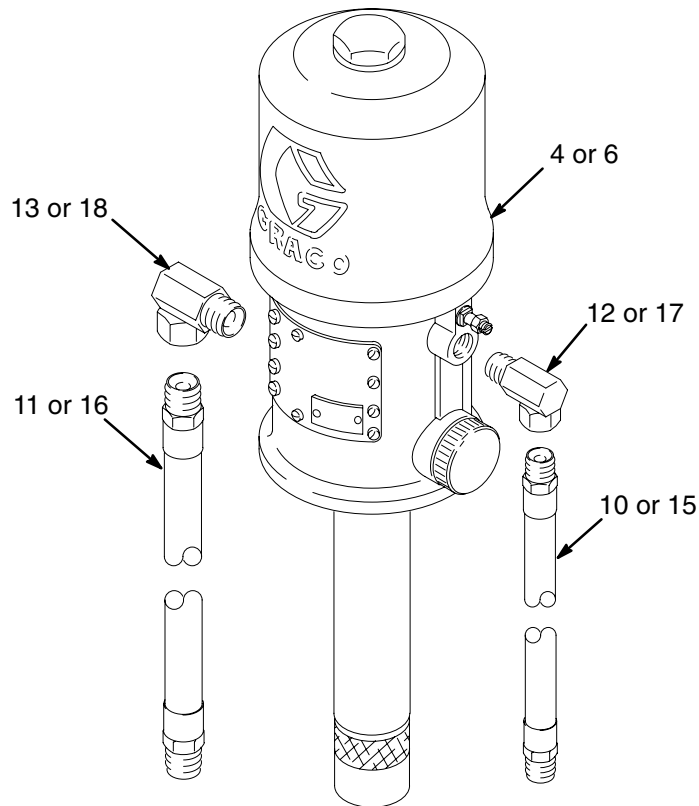

01498

Parts Lists

Model 225852

5:1 Fire-Ball 300 Pump, *Includes items 6, 7, 10 to 13*

Ref No.	Part No.	Description	Qty.
6	203876	5:1 FIRE-BALL 300 PUMP, stubby <i>See manual 306518 for parts.</i>	1
7	222062	HOSE & FITTING KIT <i>See parts list to the right.</i>	1

Model 225853

10:1 Fire-Ball 425 Pump, *Includes items 4, 5, 15 to 18*

Ref No.	Part No.	Description	Qty.
4	205626	10:1 FIRE-BALL 425 PUMP, stubby <i>See manual 308655 for parts.</i>	1
5	222068	HOSE & FITTING KIT <i>See parts list to the right.</i>	1

Model 222062

Hose Kit for Fire-Ball 300 pump

Ref No.	Part No.	Description	Qty.
10	204560	AIR HOSE, 3/8" ID, cpld 3/8-14 npt (mbe), 18" (457 mm)	1
11	220598	FLUID HOSE, 1/2" ID, cpld 1/2-14 npt(mbe), 18" (457 mm)	1
12	155494	UNION, 90°, 3/8-14 npt(m) x 3/8 npsm(f) swivel	1
13	155470	UNION, 90°, 1/2-14 npt(m) x 1/2 npsm(f) swivel	1

Model 222068

Hose Kit for Fire-Ball 425 pump

Ref No.	Part No.	Description	Qty.
15	218093	AIR HOSE, 1/2" ID, cpld 1/2-14 npt (mbe), 18" (457 mm)	1
16	109108	FLUID HOSE, 3/4" ID, cpld 3/4-14 npt(mbe), 18" (457 mm)	1
17	155470	UNION, 90°, 1/2-14 npt(m) x 1/2 npsm(f) swivel	1
18	160327	UNION, 90°, 3/4-14 npt(m) x 3/4 npsm(f) swivel	1

The Graco Warranty and Disclaimers

WARRANTY

Graco warrants all equipment manufactured by it and bearing its name to be free from defects in material and workmanship on the date of sale to the original purchaser for use. As purchaser's sole remedy for breach of this warranty, Graco will, for a period of twelve months from the date of sale, repair or replace any part of the equipment proven defective. This warranty applies only when the equipment is installed, operated and maintained in accordance with Graco's written recommendations.

This warranty does not cover, and Graco shall not be liable for, any malfunction, damage or wear caused by faulty installation, misapplication, abrasion, corrosion, inadequate or improper maintenance, negligence, accident, tampering, or substitution of non-Graco component parts. Nor shall Graco be liable for malfunction, damage or wear caused by the incompatibility with Graco equipment of structures, accessories, equipment or materials not supplied by Graco, or the improper design, manufacture, installation, operation or maintenance of structures, accessories, equipment or materials not supplied by Graco.

This warranty is conditioned upon the prepaid return of the equipment claimed to be defective to an authorized Graco distributor for verification of the claim. If the claimed defect is verified, Graco will repair or replace free of charge any defective parts. The equipment will be returned to the original purchaser transportation prepaid. If inspection of the equipment does not disclose any defect in material or workmanship, repairs will be made at a reasonable charge, which charges may include the costs of parts, labor and transportation.

DISCLAIMERS AND LIMITATIONS

The terms of this warranty constitute purchaser's sole and exclusive remedy and are in lieu of any other warranties (express or implied), including warranty of merchantability or warranty of fitness for a particular purpose, and of any non-contractual liabilities, including product liabilities, based on negligence or strict liability. Every form of liability for direct, special, or consequential damages or loss is expressly excluded and denied. In no case shall Graco's liability exceed the amount of the purchase price. Any action for breach of warranty must be brought within two (2) years of the date of sale.

EQUIPMENT NOT COVERED BY GRACO WARRANTY

Graco makes no warranty, and disclaims all implied warranties of merchantability and fitness for a particular purpose, with respect to accessories, equipment, materials, or components sold but not manufactured by Graco. These items sold, but not manufactured by Graco (such as electric motor, switches, hose, etc.) are subject to the warranty, if any, of their manufacturer. Graco will provide purchaser with reasonable assistance in making any claim for breach of these warranties.

Graco Information

TO PLACE AN ORDER, contact your Graco distributor, or call one of the following numbers to identify the distributor closest to you:

1-800-533-9655 Toll Free

612-623-6928

612-378-3590 Fax

*All written and visual data contained in this document reflects the latest product information available at the time of publication.
Graco reserves the right to make changes at any time without notice.*

This manual contains English. MM 306520

Graco Headquarters: Minneapolis
International Offices: Belgium, Korea, China, Japan

www.graco.com

306520 08/1955, Revised 01/2007