



AdBlue[®] Dispensing Systems

Solutions for Clean Diesel Exhaust Fluid Transfer



PROVEN QUALITY. LEADING TECHNOLOGY.

Clean. Fast. Efficient.



Why Graco?

Value built-in

Choose from a variety of dispense solutions. From the economical drum package to the high-performance tote packages, every solution is designed with the highest quality components for trouble free operation. Uses long lasting BSPP seals for fewer leaks and a clean work environment. Field proven pump provides years of reliable operation.

Efficient, money saving operation

Versatile Husky 515 pump delivers up to 57 l/min (15 gpm) works on as little as 1.4 bar (20 psi) for money saving efficiency and is capable of 3.4 bar (50 psi) to provide high output over a long run of hose or piping. Powerful design has superior suction and lift for deep tanks or totes. Choose the best of both in one pump—power plus efficiency.

Clean transfer solution

Quick change inlet kit provides strong seal between drum coupler and insert to prevent tank to tank contamination—easy to disconnect pump from empty tank leaving behind contaminated down tube.

Everything you need right out of the box

A cost-effective system designed to serve multiple markets and applications.

Choose from three configurations to get exactly what you need for your business.

The Complete package—everything you need to get up and running fast.

All packages come with quick changeover inlet kit, air controls, air-operated double diaphragm pump, supply hose and auto shut-off nozzle. Simple bolt together assembly with no special tools.

Tote mount



Wall mount



208 l drum mount



Note: In-line meter is optional. Check ordering information for the package that best fits your needs.

Simple to Set-up and Change Over

Gives you trouble-free operation

Graco's complete out of the box solutions use the field-proven Husky 515 pump and high quality components with stainless steel connections at the inlet and outlet, optional meter and choice of nozzles for your specific needs. AdBlue® is 32.5% high purity urea. Fluid purity is critical and contamination of as little as +/-0,08 percent will prevent AdBlue® from meeting specifications mandated by the International Standards Organization (ISO). Graco's AdBlue® equipment is designed for fast drum/tote change overs without risk of transferring impurities from tank to tank.

Standard Air Control

Comes complete with pressure gauge and air adjustment for total control over your fluid dispense (air nipple not included).

Choice of Nozzle

High-impact polypropylene nozzle offers dependable operation at a low cost. Heavy-duty stainless steel dispense nozzle has convenient auto shut-off to prevent overflow.

Quick Changeover Inlet Kit

Provides strong seal and prevents tank to tank contamination-easy to disconnect pump from empty tank leaving behind contaminated down tube.

Dependable Field-proven Pump

The Husky 515 double diaphragm pump (57 lpm free flow) is self priming and operates on as little as 1.4 bar (20 psi) with polypropylene materials that will not interact with the AdBlue® chemistry. Provides superior suction and lift for deep totes or tanks.

Premium Hoses

Oil resistant hose extends life and BSPP connections with seals on inlet and outlet provide trouble free performance—eliminates leaking at joints and prevents crystallization.

Quick-secure Bracket

Easily removable with simple thumb screws for effortless changeovers.



Technical Specifications

XD 30 AdBlue® Hose Reel



Size 30

XD SERIES SIZE 30	
A	229 mm (9.0")
B	546 mm (21.50")
C	659.45 mm (25.96")
D	561.73 mm (22.12")
E	588 mm (23.10")
F	700.82 mm (27.60")

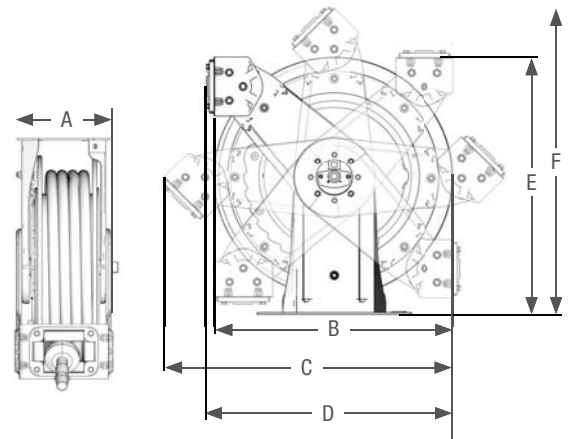

	With Hose	Without Hose
White	HSDD5A	HSDDDA
Blue	HSDD5B	HSDDDB
Yellow	HSDD5F	HSDDDF
Hose Size	3/4" x 15 m	-
Pressure	0.34 MPa	0.34 MPa
Inlet connection	3/4" BSPP (SST)	3/4" BSPP (SST)
Outlet connection	3/4" BSPP (SST)	3/4" BSPP (SST)
Operating temp	-11 to 60 °C (12 to 140 °F)	-11 to 60 °C (12 to 140 °F)

NOTE: Hose Inlet Kit for all XD Reels sold separately.

Ordering Information

Tote/Wall AdBlue® Package with Meter	
24F531	Package includes: Air-Operated Diaphragm pump (24G745), Tote/Wall mounting bracket with nozzle holder (24F870), Automatic shut off SST nozzle with swivel (24F529), AdBlue® meter package for auto nozzle (24H293), Quick connect inlet kit (24F532), AdBlue® Inlet hose - 1.83 m - 3/4" BSPP (M) (124581), AdBlue® Dispense hose - 6.1 m - 3/4" BSPP, MBE (124603), Air Controls: Regulator (110147), vent (110223) - 3.5 bar (50 psi) valve (124963)
Tote/Wall AdBlue® Package without Meter	
24F878	Package includes: Air-Operated Diaphragm pump (24G745), Tote/Wall mounting bracket with nozzle holder (24F870), Automatic shut off SST nozzle with swivel (24F529), Quick connect inlet kit (24F532), AdBlue® Inlet hose - 1.83 m - 3/4" BSPP (M) (124581), AdBlue® Dispense hose - 6.1 m - 3/4" in BSPP, MBE (124603), Air Controls: Regulator (110147), vent (110223) - 3.5 bar (50 psi) valve (124963)
Drum AdBlue® Package without Meter	
24F947	Air-Operated Diaphragm pump (24G745), Drum mounting bracket with nozzle holder (24F679), Manual nozzle (125078), Quick connect inlet kit (24F532), AdBlue® Inlet hose- 61 cm, - 3/4" BSPP X cut (124875), AdBlue® Dispense hose - 3,66 m - 3/4" BSPP (M) x cut end (125079), Air Controls: Regulator (110147), vent (110223) - 3.5 bar (50 psi) valve (124963)
Pumps	
24G745	Air-Operated Diaphragm pump (56 l/min free flow, polypropylene) - 3/4" BSPP (F)
24G636	Pump, hand, AdBlue® compatible
Reels	
HSDD5A	Reel, hose, 3/4" x 15 m - AdBlue® white
HSDD5B	Reel, hose, 3/4" x 15 m - AdBlue® blue
HSDD5F	Reel, hose, 3/4" x 15 m - AdBlue® yellow
HSDD5F	Reel, hose, bare - AdBlue® white
HSDDDA	Reel, hose, bare - AdBlue® blue
HSDDDF	Reel, hose, bare - AdBlue® yellow
Mounting	
24F870	Tote/Wall mounting bracket with nozzle holder
24F679	Drum mounting bracket with nozzle holder
124541	Holder, nozzle bath
Nozzles	
124398	Automatic shut off SST nozzle without swivel-3/4" BSPP (F)
24F529	Automatic shut off SST nozzle with swivel-3/4" BSPP (F)
125078	Manual nozzle
Meter Kits	
24G738	Meter only, 1/2" BSPP (F/F)
24H293	Meter Kit with fittings for SST auto nozzle

Ordering Information

Quick Connect Inlet Kits and Accessories	
24F532	Quick connect inlet kit
124548	Drum coupler
124549	Drum insert with NPS thread
125014	Drum insert with buttress thread
124550	Down tube
Hoses	
124875	AdBlue® Inlet hose - 61 cm - 3/4" BSPP (M) x cut end
124581	AdBlue® Inlet hose - 1.83 m - 3/4" BSPP (M) x cut end
125079	AdBlue® dispense hose - 3.66 m - 3/4" BSPP (M) x cut end
124671	AdBlue® dispense hose - 3.66 m - 3/4" BSPP (MBE)
124603	AdBlue® dispense hose - 6.1 m - 3/4" BSPP (MBE)
125074	AdBlue® dispense hose - 6.1 m - 3/4" BSPP (M) x cut end
125478	AdBlue® dispense hose - 1.2 m - 3/4" BSPP cut both ends (for hand pump only)
125242	AdBlue® dispense hose - 15 m - 3/4" BSPP x 3/4" BSPP

Graco is your number one source for dependable AdBlue® equipment!

NEW
Additions to the AdBlue®
Dispensing Systems!



HSSD5B



24G636



24F947 Drum AdBlue®
Package without Meter



24F529



24F531
Tote/Wall AdBlue®
Package with Meter



24F679



24F532 Quick connect inlet kit (above):
Includes: 24F532 drum coupler, 124549
drum insert and 124550 down tube



24F870



24G745



24H293



124671



ABOUT GRACO

Founded in 1926, Graco is a world leader in fluid handling systems and components. Graco products move, measure, control, dispense and apply a wide range of fluids and viscous materials used in vehicle lubrication, commercial and industrial settings.

The company's success is based on its unwavering commitment to technical excellence, world-class manufacturing and unparalleled customer service. Working closely with qualified distributors, Graco offers systems, products and technology that set the quality standard in a wide range of fluid handling solutions. Graco provides equipment for spray finishing, protective coating, paint circulation, lubrication, and dispensing sealants and adhesives, along with power application equipment for the contractor industry. Graco's ongoing investment in fluid management and control will continue to provide innovative solutions to a diverse global market.

GRACO LOCATIONS

MAILING ADDRESS

P.O. Box 1441
Minneapolis, MN 55440-1441
Tel: 612-623-6000
Fax: 612-623-6777

AMERICAS

MINNESOTA

Worldwide Headquarters
Graco Inc.
88-11th Avenue N.E.
Minneapolis, MN 55413

EUROPE

BELGIUM

European Headquarters
Graco BVBA
Industrieterrein-Oude Bunders
Slakweidestraat 31
3630 Maasmechelen,
Belgium
Tel: 32 89 770 700
Fax: 32 89 770 777

ASIA PACIFIC

AUSTRALIA

Graco Australia Pty Ltd.
Suite 17, 2 Enterprise Drive
Bundoora, Victoria 3083
Australia
Tel: 61 3 9468 8500
Fax: 61 3 9468 8599

CHINA

Graco Hong Kong Ltd.
Shanghai Representative Office
Building 7
1029 Zhongshan Road South
Huangpu District
Shanghai 200011
The People's Republic of China
Tel: 86 21 649 50088
Fax: 86 21 649 50077

INDIA

Graco Hong Kong Ltd.
India Liaison Office
Room 432, Augusta Point
Regus Business Centre 53
Golf Course Road
Gurgaon, Haryana
India 122001
Tel: 91 124 435 4208
Fax: 91 124 435 4001

JAPAN

Graco K.K.
1-27-12 Hayabuchi
Tsuzuki-ku
Yokohama City, Japan 2240025
Tel: 81 45 593 7300
Fax: 81 45 593 7301

KOREA

Graco Korea Inc.
Shinhan Bank Building
4th Floor #1599
Gwanyang-Dong, Dongan-Ku,
Anyang-si, Korea 431-060
Tel: 82 31 476 9400
Fax: 82 31 476 9801

All written and visual data contained in this document are based on the latest product information available at the time of publication. Graco reserves the right to make changes at any time without notice.

Graco is certified ISO 9001.

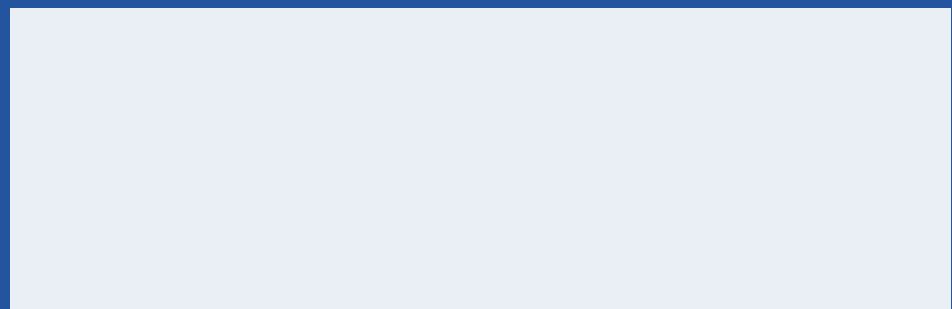

Europe
+32 89 770 700
FAX +32 89 770 777
WWW.GRACO.COM