

Instructions-Parts List



ALUMINUM

Husky™ 716 Air-Operated Diaphragm Pump

308573ZAB

EN

Used to evacuate and transfer fluids.

100 psi (0.7 MPa, 7 bar) Maximum Fluid Working Pressure

100 psi (0.7 MPa, 7 bar) Maximum Air Input Pressure

Part No. 241906, Series D

Buna-N diaphragms and balls

Restricted air inlet to maximize pumping efficiency for evacuation systems



Important Safety Instructions

Read all warnings and instructions in this manual.
Save these instructions.

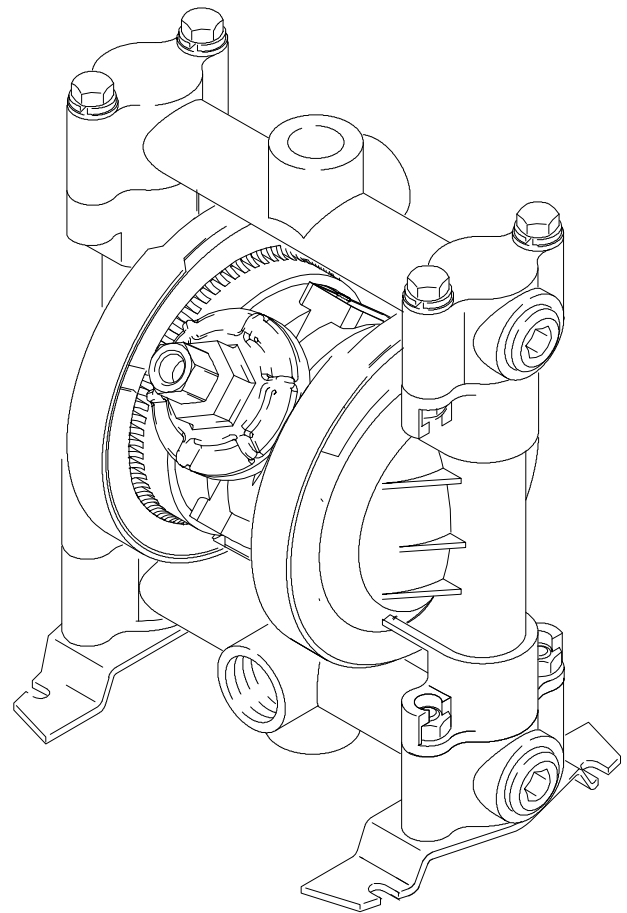

PROVEN QUALITY. LEADING TECHNOLOGY.

Table of Contents

Symbols	2
Safety Warnings	2
Installation	4
Operation	10
Maintenance	12
Troubleshooting	14
Service	15
Parts	20
Torque Sequence	22
Dimensions	23
Technical Data	24
Graco Standard Warranty	28
Graco Information	28

Symbols

Warning Symbol



This symbol alerts you to the possibility of serious injury or death if you do not follow the instructions.

Caution Symbol



This symbol alerts you to the possibility of damage to or destruction of equipment if you do not follow the instructions.

! WARNING



INSTRUCTIONS

EQUIPMENT MISUSE HAZARD

Equipment misuse can cause the equipment to rupture or malfunction and result in serious injury.

- This equipment is for professional use only.
- Read all instruction manuals, tags, and labels before operating the equipment.
- Use the equipment only for its intended purpose. If you are not sure, call your Graco distributor.
- Do not alter or modify this equipment. Use only genuine Graco parts and accessories.
- Check equipment daily. Repair or replace worn or damaged parts immediately.
- Do not exceed the maximum working pressure of the lowest rated component in your system. This equipment has a **100 psi (0.7 MPa, 7 bar) maximum working pressure at 100 psi (0.7 MPa, 7 bar) maximum incoming air pressure.**
- Use fluids and solvents which are compatible with the equipment wetted parts. Refer to the **Technical Data** section of all equipment manuals. Read the fluid and solvent manufacturer's warnings.
- Do not use 1,1,1-trichloroethane, methylene chloride, other halogenated hydrocarbon solvents or fluids containing such solvents in aluminum pumps. Such use could result in a serious chemical reaction, with the possibility of explosion.
- Do not use hoses to pull equipment.
- Route hoses away from traffic areas, sharp edges, moving parts, and hot surfaces. Do not expose Graco hoses to temperatures above 82°C (180°F) or below -40°C (-40°F).
- Do not lift pressurized equipment.
- Wear hearing protection when operating this equipment.
- Comply with all applicable local, state, and national fire, electrical, and safety regulations.

WARNING



TOXIC FLUID HAZARD

Hazardous fluid or toxic fumes can cause serious injury or death if splashed in the eyes or on the skin, inhaled, or swallowed.

- Know the specific hazards of the fluid you are using.
- Store hazardous fluid in an approved container. Dispose of hazardous fluid according to all local, state and national guidelines.
- Always wear protective eyewear, gloves, clothing and respirator as recommended by the fluid and solvent manufacturer.
- Pipe and dispose of the exhaust air safely, away from people, animals, and food handling areas. If the diaphragm fails, the fluid is exhausted along with the air. See **Air Exhaust Ventilation** on page 9.



FIRE AND EXPLOSION HAZARD

Improper grounding, poor ventilation, open flames or sparks can cause a hazardous condition and result in a fire or explosion and serious injury.

- Ground and bond the equipment. Refer to **Grounding** on page 4.
- If there is any static sparking or you feel an electric shock while using this equipment, **stop pumping immediately**. Do not use the equipment until you identify and correct the problem.
- Provide fresh air ventilation to avoid the buildup of flammable fumes from solvents or the fluid being pumped.
- Pipe and dispose of the exhaust air safely, away from all sources of ignition. If the diaphragm fails, the fluid is exhausted along with the air. See **Air Exhaust Ventilation** on page 9.
- Keep the work area free of debris, including solvent, rags, and gasoline.
- Electrically disconnect all equipment in the work area.
- Extinguish all open flames or pilot lights in the work area.
- Do not smoke in the work area.
- Do not turn on or off any light switch in the work area while operating or if fumes are present.
- Do not operate a gasoline engine in the work area.

Installation

Grounding

⚠ WARNING

FIRE AND EXPLOSION HAZARD
This pump must be grounded. Before operating the pump, ground the system as explained below. Also read the section **FIRE OR EXPLOSION HAZARD** on page 3.

Check your system electrical continuity after the initial installation, and then set up a regular schedule for checking continuity to be sure proper grounding is maintained.

To reduce the risk of static sparking, ground the pump and all other equipment used or located in the pumping area. Check your local electrical code for detailed grounding and bonding instructions for your area and type of equipment.

Ground and bond all of this equipment:

- *Pump:* attach a ground wire (Y) to the grounding strip (111) with the screw (121), lockwasher (122) and nut (123), as shown in Fig. 1, and per code. Connect the clamp end of the ground wire to a true earth ground. Order Part No. 222011 Ground Wire and Clamp.

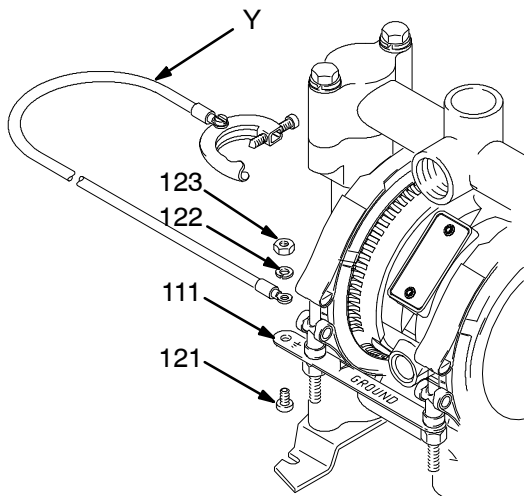

Fig. 1

9247A

- *Air and fluid hoses:* use only electrically conductive hoses.
- *Air compressor:* follow the manufacturer's recommendations.
- *Suction device nozzle:* must be bonded to metal container from which it is suctioning by firm metal-to-metal contact to a properly grounded suction hose and pump.
- *Piping, valves and fittings:* use only electrically conductive materials. Bond and ground per code.
- *Solvent pails used when flushing:* follow your local code. Use only metal pails, which are conductive. Do not place the pail on a non-conductive surface, such as paper or cardboard, which interrupts the grounding continuity.
- *Waste storage tank:* follow your local code.

Installation

Typical Installation Description

Fig. 2 shows a system for the fast evacuation of gear oil from vehicles. One centrally-mounted Husky 716 pump can have suction line drops to up to four service bays, when activated singly. Interchangeable, nylon suction wands are available to fit most differentials. One control valve at each bay remotely activates the pump and quickly suctions the gear oil. This system can also be used to remove waste oil from rolling waste oil drain carts, using a high capacity wand.

Fig. 3 shows a system for the fast evacuation of waste oil from rolling waste oil receivers, or for general fluid transfer applications. In waste oil evacuation systems, roll the receivers up to a centrally mounted Husky 716 pump. Couple a quick disconnect coupler to a mating connector on the waste oil receiver. Turn on the pump and the oil is quickly evacuated from the receiver and sent to a waste oil storage tank.

General Information

- The Typical Installations in Figs. 2 and 3 are only guides for selecting and installing system components. Contact your Graco distributor for assistance in planning a system to suit your needs.
- Always use Genuine Graco Parts and Accessories.
- Installation and use must be in accordance with the Flammable and Combustible Liquids Code (NFPA 30) and Automotive and Marine Service Station Code (NFPA 30A) and must comply with all local, state and federal codes.
- Use a compatible, liquid thread sealant on all male threads. Tighten all connections firmly to avoid air or fluid leaks.
- Reference numbers and letters in parentheses refer to the callouts in the Figures and the parts lists on pages 20 to 21.
- Always mount the pump in the upright position as shown in Figs. 2 and 3. A non-upright position prevents checks from operating properly.

CAUTION

Safe Operating Temperatures

Minimum: 40° F (4° C)

Maximum: 225° F (107° C)

These temperatures are based upon mechanical stress only and may be significantly altered by pumping certain chemicals. Consult engineering guides for chemical compatibilities and temperature limits, or contact your Graco distributor.

WARNING



TOXIC FLUID HAZARD

Hazardous fluid or toxic fumes can cause serious injury or death if splashed in the eyes or on the skin, inhaled, or swallowed.

- Read **TOXIC FLUID HAZARD** on page 3.
- Use fluids and solvents which are compatible with the equipment wetted parts. Refer to the **Technical Data** section of all equipment manuals. Read the fluid and solvent manufacturer's warnings.

Tightening Screws Before First Use

Before using the pump for the first time, check and retorque all external fasteners. See **Torque Sequence**, page 22. After the first day of operation, retorque the fasteners. Although pump use varies, a general guideline is to retorque fasteners every two months.

Mountings

- Be sure the mounting surface can support the weight of the pump, hoses, and accessories, as well as the stress caused during operation.
- The Husky 716 Pump can be used in a variety of installations. See Figs. 2 and 3 for examples.
- Secure the pump with screws and nuts.

Installation

Example of a Gear Oil Receiver Evacuation System

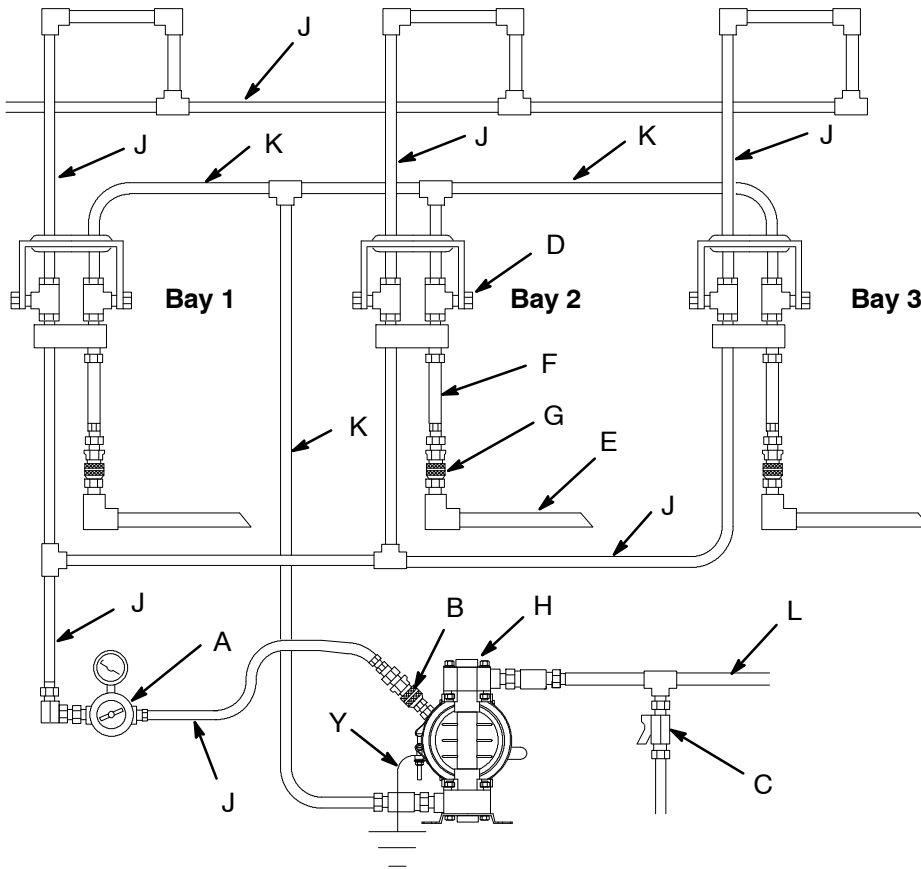

KEY

- A Pump air regulator
- B Air line quick coupler (required)
- C Fluid drain valve (required)
- D Control valve
- E Suction wand
- F Suction hose
- G Fluid quick coupler
- H Husky 716 pump
- J Electrically conductive, bonded air supply line
- K Electrically conductive, bonded fluid line to pump
- L Electrically conductive, bonded waste oil line to storage tank
- Y Ground wire (required; See page 4 for installation instructions. Pump must be properly grounded and entire system electrically bonded.)

Fig. 2

9249A

Example of a Waste Oil Evacuation System, or General Fluid Transfer Application

Shown with fluid inlet and outlet ports facing forward (see page 8).

NOTE: Air inlet restrictor may be removed for higher flow capabilities.

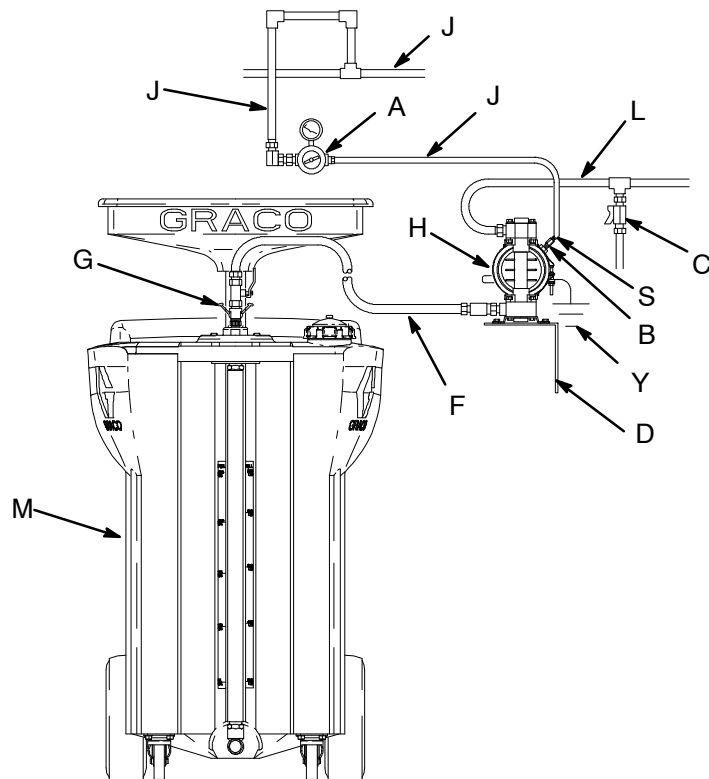

KEY

- A Pump air regulator
- B Air line quick coupler (required)
- C Fluid drain valve (required)
- D Wall-mount bracket (Part No. 224835)
- F Electrically conductive suction hose
- G Fluid quick coupler
- H Husky 716 pump
- J Electrically conductive, bonded air supply line
- L Electrically conductive, bonded waste oil line to storage tank
- M Waste oil receiver
- S 90° Elbow (required for wall mount applications)
- Y Ground wire (required; See page 4 for installation instructions. Pump must be properly grounded and entire system electrically bonded.)

Fig. 3

9250A

Installation

Air Line

WARNING

An air line quick coupler (B) is required in your system to relieve air trapped between this valve and the pump. See Fig. 2. Trapped air can cause the pump to cycle unexpectedly, which could result in serious injury, including splashing in the eyes or on the skin, injury from moving parts, or contamination from hazardous fluids.

CAUTION

Before connecting the permanent air line to the regulator (A), blow out all lines with air to remove contaminants that can clog or damage the regulator, hose, or pump air valve.

CAUTION

The pump exhaust air may contain contaminants. Ventilate to a remote area if the contaminants could affect your fluid supply. See **Air Exhaust Ventilation** on page 9.

1. Install the air line accessories as shown in Fig. 2. Mount these accessories on the wall or on a bracket. Be sure the air line supplying the accessories is electrically conductive and bonded.
2. Use the air regulator (A) to control the pump fluid outlet pressure. The fluid pressure will be the same as the setting on the regulator gauge.
3. Install an electrically conductive, flexible air hose (J) between the regulator (A) and the 1/4 npt(f) pump air inlet (air restrictor in evacuation applications). Use a minimum 1/4 in. (6.3 mm) ID air hose. Screw an air line quick disconnect coupler (B) onto the end of the air hose (J), and screw the mating fitting into the pump air inlet snugly. Do not connect the coupler (B) to the fitting yet.

Fluid Supply Line

- Use electrically conductive fluid hoses (J or F). Be sure the lines are bonded all the way from the fluid supply to the grounded pump.
- The pump fluid inlet is 3/4 npt(f). See Fig. 4. Screw the fluid fitting into the pump inlet snugly. **Do not overtighten.**
- For the Gear Oil Evacuation System, install a control valve (D) and an appropriate wand (E). See Fig. 2.
- For the Waste Oil Receiver Evacuation System, connect an appropriate suction hose (F) and fluid quick coupler (G) between the pump fluid inlet and the waste oil receiver (M). See Fig. 3.
- If the inlet pressure to the pump is more than 25% of the outlet working pressure, the ball check valves will not close fast enough, resulting in inefficient pump operation.
- At inlet fluid pressures greater than 15 psi (100 kPa, 1.0 bar), diaphragm life will be shortened.

Fluid Outlet Line

WARNING

A fluid drain valve (C) is required in your system to relieve pressure in the hose if it is plugged. See Figs. 2 and 3. The drain valve reduces the risk of serious injury, including splashing in the eyes or on the skin, or contamination from hazardous fluids when relieving pressure. Install the valve close to the pump fluid outlet.

- Use electrically conductive fluid hoses (L). Be sure the lines are bonded all the way from the grounded pump to the waste storage tank.
- The pump fluid outlet is 3/4 npt(f). See Fig. 4. Screw the fluid fitting into the pump outlet snugly. **Do not overtighten.**
- Install a fluid drain valve (C) near the fluid outlet. See the **WARNING** above.
- Also read **Fluid Pressure Relief Valve**, on page 8.

Installation

Changing the Orientation of the Fluid Inlet and Outlet Ports

You can change the direction of the fluid inlet and outlet manifolds (102), if desired. Model 241906 is shipped with the fluid inlet manifold pointing toward the air inlet and the fluid outlet manifold pointing away from the air inlet. See Fig. 4.

1. Remove the bolts (105) holding the manifold (102) to the covers (101). Save the attaching hardware.
2. Turn the manifold to the desired position, and reinstall the hardware. Torque the bolts (105) to 80 to 90 in-lb (9 to 10 N•m). See **Torque Sequence**, page 22.

- 1 Torque to 80-90 in-lb (9-10 N•m). See **Torque Sequence**, page 22.
- 2 1/4 npt(f) Air Inlet
- 3 3/4 npt(f) Fluid Inlet
- 4 3/4 npt(f) Fluid Outlet (on opposite side)

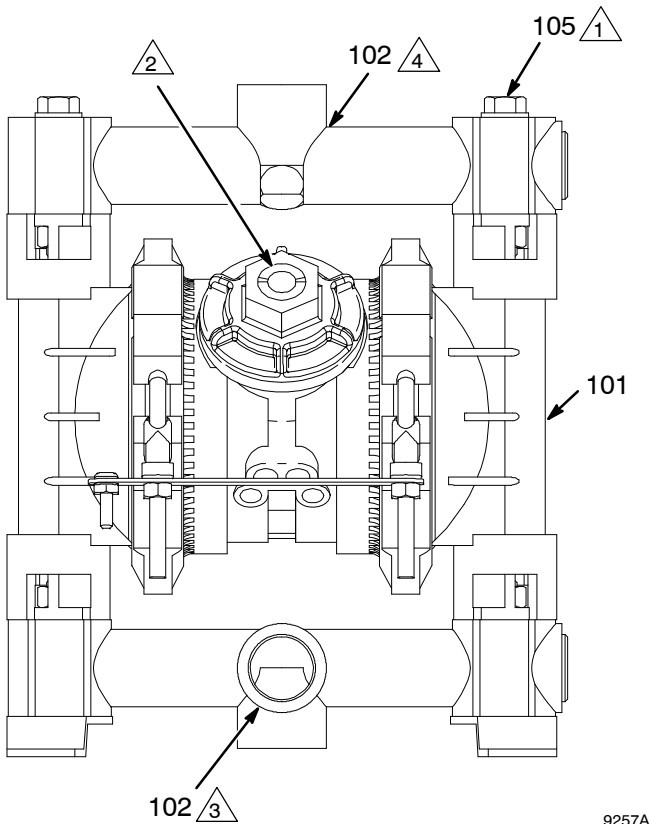

Fig. 4

9257A

Fluid Pressure Relief Valve

CAUTION

Some systems may require installation of a pressure relief valve at the pump outlet to prevent overpressurization and rupture of the pump or hose. See Fig. 5.

Thermal expansion of fluid in the outlet line can cause overpressurization. This can occur when using long fluid lines exposed to sunlight or ambient heat, or when pumping from a cool to a warm area (for example, from an underground tank).

Overpressurization can also occur if the Husky pump is being used to feed fluid to a piston pump, and the intake valve of the piston pump does not close, causing fluid to back up in the outlet line.

Pressure Relief Kit 238428 is available for use on aluminum Husky 716 pumps and may be purchased separately.

KEY

- N 3/4 npt(f) Fluid Inlet Manifold
- P 3/4 npt(f) Fluid Outlet Manifold
- R Pressure Relief Valve, Part No. 113497

- 5 Install valve between fluid inlet and outlet ports. Other parts shown are included in Pressure Relief Kit 238428.

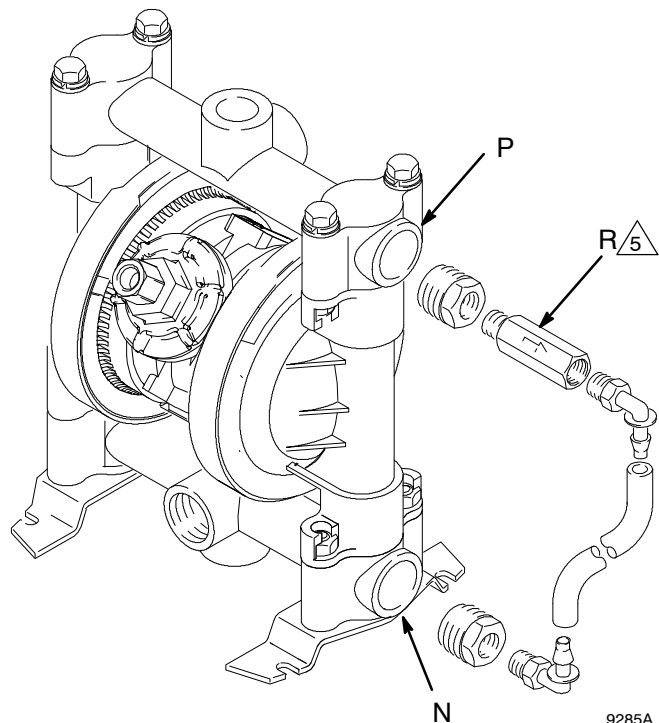

Fig. 5

9285A

Installation

Air Exhaust Ventilation

⚠ WARNING

FIRE AND EXPLOSION HAZARD
Be sure to read **FIRE OR EXPLOSION HAZARD** and **TOXIC FLUID HAZARD** on page 3, before operating this pump.

Be sure the system is properly ventilated for your type of installation. You must vent the exhaust to a safe place, away from people, animals, food handling areas, and all sources of ignition when pumping flammable or hazardous fluids.

Diaphragm failure will cause the fluid being pumped to exhaust with the air. Place an appropriate container at the end of the air exhaust line to catch the fluid. See Fig. 6.

The air exhaust port is 3/8 npt(f). Do not restrict the air exhaust port. Excessive exhaust restriction can cause erratic pump operation.

To exhaust to a remote location:

1. Remove the muffler (W) from the pump air exhaust port.
2. Install an electrically conductive air exhaust hose (X) and connect the muffler to the other end of the hose. The minimum size for the air exhaust hose is 3/8 in. (10 mm) ID. If a hose longer than 15 ft (4.57 m) is required, use a larger diameter hose. Avoid sharp bends or kinks in the hose.
3. Place a container (Z) at the end of the air exhaust line to catch fluid in case a diaphragm ruptures. See Fig. 6.

VENTING EXHAUST AIR
See Fig. 2 for accessories

KEY

- W Muffler
- X Electrically Conductive Air Exhaust Hose
- Z Container for Remote Air Exhaust

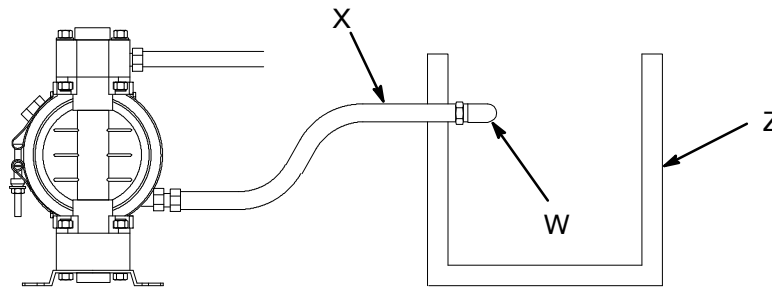

Fig. 6

9253A

Operation

Pressure Relief Procedure

WARNING

PRESSURIZED EQUIPMENT HAZARD

The equipment stays pressurized until pressure is manually relieved. To reduce the risk of serious injury from pressurized fluid, accidental spray from the gun or splashing fluid, follow this procedure whenever you

- Are instructed to relieve pressure
- Stop pumping
- Check, clean or service any system equipment
- Install or clean fluid nozzles

1. Close the air regulator by turning counterclockwise as far as possible.
2. Disconnect the air line quick coupler to relieve air pressure.
3. Open the dispensing valve, if used.
4. Open the fluid drain valve to relieve all fluid pressure, having a container ready to catch the drainage.

Flush the Pump Before First Use

The pump was tested in water. If water could contaminate the fluid you are pumping, flush the pump thoroughly with a compatible solvent. Follow the steps under **Starting and Adjusting the Pump**.

Starting and Adjusting the Pump

All Systems

WARNING



TOXIC FLUID HAZARD

Hazardous fluid or toxic fumes can cause serious injury or death if splashed in the eyes or on the skin, inhaled, or swallowed. Do not lift a pump under pressure. If dropped, the fluid section may rupture. Always follow the **Pressure Relief Procedure** at left before lifting the pump.

1. Be sure the pump is properly grounded and bonded. Read **FIRE OR EXPLOSION HAZARD** on page 3.
2. Check all fittings to be sure they are tight. Use a compatible liquid thread sealant on all male threads. Tighten the fluid inlet and outlet fittings snugly. Do not overtighten the fittings into the pump.
3. **For the first startup:** Connect the fluid inlet hose to the pump and place the other end of the hose in a two quart container of oil. Start the pump following Steps 1, 3 and 4 in either of the following startup procedures. When the container is empty, shut off the air to the pump and reconnect the hose to the suction line. This procedure wets the pump internal parts to ensure maximum suction.

If you are flushing, run the pump long enough to thoroughly clean the pump and hoses. Close the air regulator. Remove the suction tube from the solvent and place it in the fluid to be pumped.

Operation

Waste Receiver Evacuation Systems, or General Fluid Transfer Applications (See Fig. 3)

1. Connect the suction hose (F) to the waste oil receiver (M) with a fluid quick coupler (G).
2. Be sure the drain valve (C) is closed.
3. Connect the air hose (J) to the pump with an air line quick coupler (B). A 90° elbow (134) is supplied for use in wall mount applications.
4. Open the air regulator (A) until the pump starts to cycle.
5. Adjust the air regulator. Do not use higher air pressure than needed for the pump to provide good suction. Increasing the pump cycle rate does not necessarily improve suction.

Gear Oil Evacuation Systems (See Fig. 2)

1. Attach an appropriate wand (E) to the suction hose (F).
2. Be sure the air inlet restrictor (125) is attached to the pump.
3. Be sure the drain valve (C) is closed.
4. Connect the air hose (J) to the pump with an air line quick coupler (B).
5. Open and set the air regulator (A) between 40 and 50 psi (280–340 kPa, 2.8–3.4 bar), adjusting for best operation.

6. Place the suction wand (E) in the differential or fluid to be pumped.
7. Pull the control valve (D) handle down to start the pump.
8. Adjust the air regulator. Do not use higher air pressure than needed for the pump to provide good suction. Increasing the pump cycle rate does not improve suction.
9. Push the control valve (D) handle up when finished. Place the wand in the holder on the control valve.

NOTE: Be sure the control valve handle is closed when the evacuation is completed. Failure to close it may prevent other service bays on the line from developing full suction.

Pump Shutdown

WARNING

To reduce the risk of serious injury whenever you are instructed to relieve pressure, always follow the **Pressure Relief Procedure** on page 10.

At the end of the work shift, **relieve the pressure.**

Maintenance

Lubrication

Do not lubricate the air line or air valve. Excessive lubrication can cause the pump to malfunction.

Flushing and Storage

WARNING

To reduce the risk of serious injury whenever you are instructed to relieve pressure, always follow the **Pressure Relief Procedure** on page 10.

Flush the pump often enough to prevent the fluid you are pumping from drying or freezing in the pump and damaging it. Flush with a fluid that is compatible with the fluid you are pumping and with the wetted parts in your system. Check with your fluid manufacturer or supplier for recommended flushing fluids and flushing frequency.

Always flush the pump and **relieve the pressure** before storing it for any length of time.

Grounding Continuity Check

Check your system electrical continuity regularly to be sure proper grounding is maintained.

Tightening Threaded Connections

Before each use, check all hoses for wear or damage, and replace as necessary. Check to be sure all threaded connections are tight and leak-free.

Check fasteners. Tighten or retorque as necessary. Although pump use varies, a general guideline is to retorque fasteners every two months. See **Torque Sequence**, page 22.

Tightening the Clamps

When tightening the clamps (109), apply thread lubricant to the bolts and **be sure** to torque the nuts (110) to 80 to 90 in-lb (9 to 10 N•m). See **Torque Sequence**, page 22. See Fig. 7.

 Apply thread lube to bolts and torque nuts to 80 to 90 in-lb (9 to 10 N•m). See **Torque Sequence**, page 22.

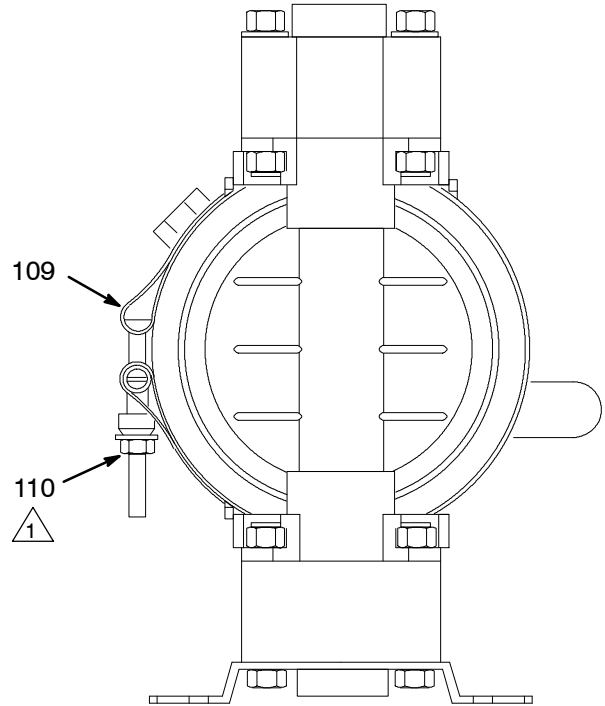

9254A

Fig. 7

Preventive Maintenance Schedule

Establish a preventive maintenance schedule, based on the pump's service history. This is especially important for prevention of spills or leakage due to diaphragm failure.

Troubleshooting

WARNING

To reduce the risk of serious injury whenever you are instructed to relieve pressure, always follow the **Pressure Relief Procedure** on page 10.

1. **Relieve the pressure.**
2. Check all possible problems and causes before disassembling the pump.

PROBLEM	CAUSE	SOLUTION
Pump will not cycle, or cycles once and stops.	Air valve is stuck or dirty.	Use filtered air.
Pump cycles at stall or fails to hold pressure at stall.	Leaky check valves or o-rings.	Replace.
	Worn check balls or guides.	Replace.
	Check ball wedged in guide.	Repair or replace.
	Worn diaphragm shaft seals.	Replace.
Pump operates erratically.	Clogged suction line.	Inspect; clear.
	Sticky or leaking check valve balls.	Clean or replace.
	Diaphragm ruptured.	Replace.
Air bubbles in fluid.	Suction line is loose.	Tighten.
	Diaphragm ruptured.	Replace.
	Loose manifolds or damaged manifold o-rings.	Tighten manifold bolts or nuts; replace o-rings.
	Loose fluid side diaphragm plates.	Tighten.
Fluid in exhaust air.	Diaphragm ruptured.	Replace.
	Loose fluid side diaphragm plates.	Tighten.
	Worn diaphragm shaft seals.	Replace.
Pump exhausts air from clamps.	Loose clamps.	Tighten clamp nuts.
	Air valve o-ring is damaged.	Inspect; replace.
Pump leaks fluid from check valves.	Worn or damaged check valve o-rings.	Inspect; replace.
No fluid output, and pump cycles rapidly.	Pump mounted incorrectly.	Mount the pump in the upright position.

Service

Air Valve (Husky 716 Pumps)

NOTE: Air Valve Repair Kit 241657 is available. Parts included in the kit are marked with a dagger (†) in Fig. 8 and in the Parts Drawings and Lists. A tube of general purpose grease 111920 is supplied in the kit. Service the air valve as follows. See Fig. 8.

⚠ WARNING

To reduce the risk of serious injury whenever you are instructed to relieve pressure, always follow the **Pressure Relief Procedure** on page 10.

1. **Relieve the pressure.**
2. Remove the cover (10) and the o-ring (4).
3. Remove the carriage plungers (7), carriages (8), carriage pins (9), and valve plate (14) from the center housing (11).
4. Clean all the parts, and inspect them for wear or damage.

NOTE: If you are installing the new Air Valve Repair Kit 241657, use all the parts in the kit.

5. Grease the lapped surface of the valve plate (14), and install the valve plate with the lapped surface facing up.
6. Grease the bores of the center housing (11), install the u-cup packings (2) on the carriage plungers (7), and slide the carriage plungers into the carriage plunger bores. See the following important installation notes:

NOTE: Center housing (11) is shown separated from the air covers, but it is not necessary to remove the air covers for this service. Leave the center housing and air covers assembled for this service.

† Included in Air Valve Repair Kit 241657

- 1 Torque to 80-100 in-lb (9.0-13.6 N•m).
- 2 Apply grease.
- 3 Apply grease to lapped face.
- 4 Apply grease to bores of center housing (11) before installing.
- 5 Seal lips face clip end (the smaller end) of carriage plunger (7).
- 6 Install with the clip ends (the smaller ends) facing toward center of center housing (11).

NOTES:

- When you install each u-cup packing (2) on each carriage plunger (7), make sure the lips of the u-cup packing face toward the **clip end** (the smaller end) of the carriage plunger.
 - When you slide the carriage plungers (7) into the bores, slide them in with the clip ends (the smaller ends) facing toward the center of the center housing (11).
7. Grease the carriage pins (9), and slide the carriage pins into the carriage pin bores.
 8. Install the carriages (8). Make sure the carriages engage the clip ends of the carriage plungers (7) and carriage pins (9).
 9. Grease the o-ring (4), and seat it in the groove around the cover opening of the center housing (11).
 10. Screw the cover (10) into the center housing, and torque the cover to 80 to 100 in-lb (9.0 to 13.6 N•m).

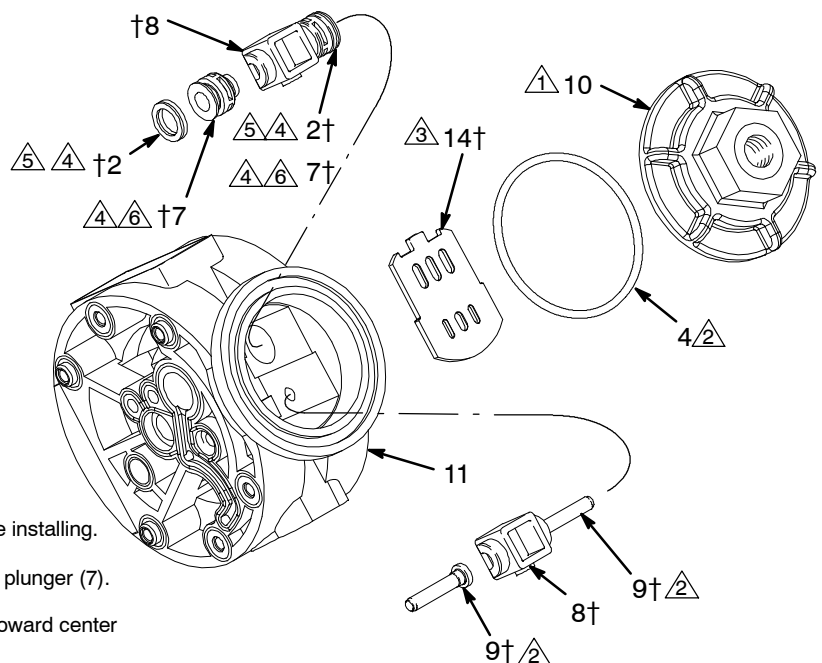

Fig. 8

9069A

Service

Tools Required

- Torque wrench
- 9/16 in. socket wrench
- O-ring pick

Ball Check Valves

NOTE: Fluid Section Repair Kit D05277 is available. Kit parts are marked with an asterisk, for example (301*). Use all the parts in the kit for the best results. Always replace the o-rings (139*) with new ones whenever they are removed for any reason.

WARNING

To reduce the risk of serious injury whenever you are instructed to relieve pressure, always follow the **Pressure Relief Procedure** on page 10.

1. **Relieve the pressure.** Disconnect all hoses.
2. Remove the pump from its mounting.
3. Unscrew the four bolts (105), washers (107), and nuts (106) holding the top manifold (102) to the covers (101). Lift the manifold off the pump. See Fig. 9.
4. Remove the outer o-ring (139*), ball stop (202*), ball (301*), ball guide (201*), and inner o-ring (139*) from each of the covers (101).
5. Turn the pump over. Remove the bolts (105), nuts (106), feet (108) and bottom manifold (102).
6. Remove the outer o-ring (139*), ball guide (201*), ball (301*), ball stop (202*), and inner o-ring (139*) from each of the covers (101).
7. Clean all parts. Inspect parts and replace worn or damaged ones.
8. Reassemble. Follow all notes in Fig. 9. Be sure the ball checks are assembled **exactly** as shown.

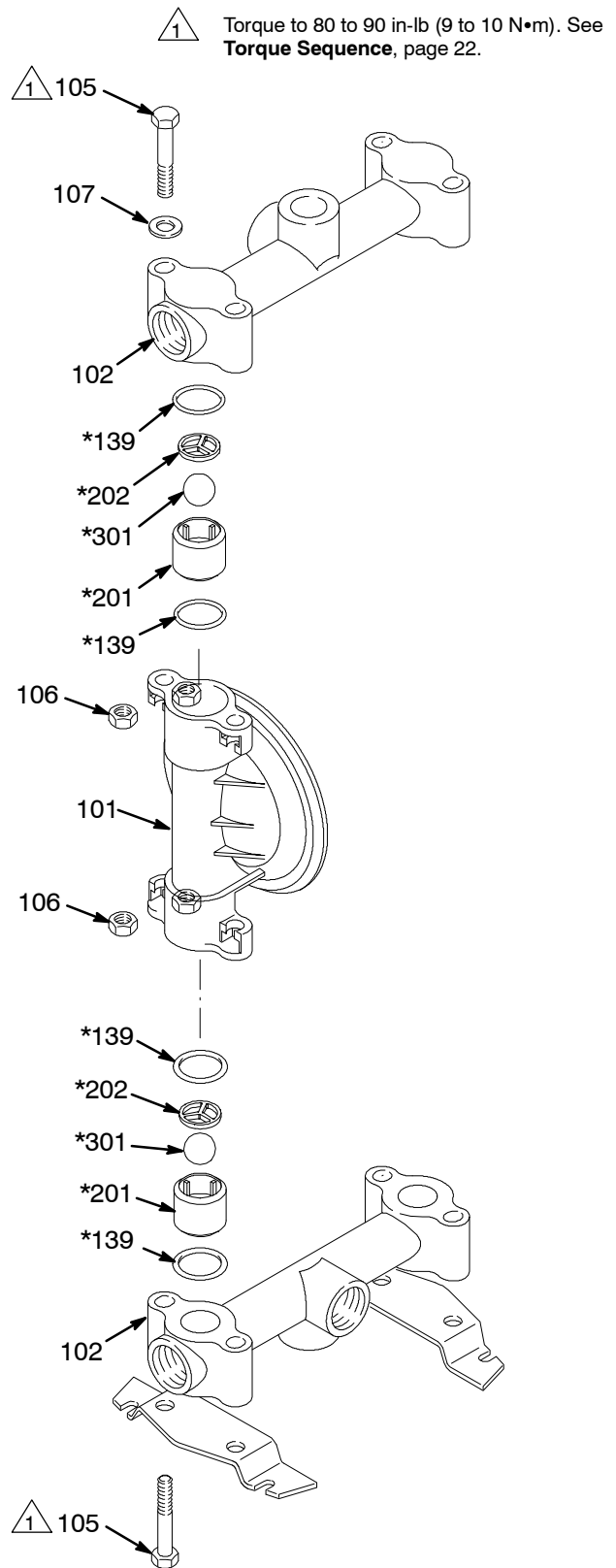

Fig. 9

9256A

Service

Diaphragms

NOTE: Fluid Section Repair Kit D05277 is available. Parts included in the kit are marked with an asterisk in Fig. 10 and in the Parts Drawings and Lists. General purpose grease 111920 and Blue Loctite® 113500 are supplied in the kit. Service the diaphragms as follows. See Fig. 10.

Disassembly

WARNING

To reduce the risk of serious injury whenever you are instructed to relieve pressure, always follow the **Pressure Relief Procedure** on page 10.

1. **Relieve the pressure.**
2. Remove the manifolds (102) and fluid covers (101).

NOTE: Make sure all the check valve parts stay in place. See Fig. 9 on page 16.
3. Remove the grounding strip from the vee clamps (109), and remove the vee clamps.
4. Remove one of the fluid-side diaphragm plates (133) (whichever one comes loose first when you use a wrench on the hex of each), and pull the diaphragm shaft out of the center housing (11).
5. Use a wrench on the flats of the diaphragm shaft (15) to remove the other fluid-side diaphragm plate (133) from the diaphragm shaft.
6. Remove the screws (141) and air covers (136), and remove all old gasket (12) material from the ends of the center housing (11) and the surfaces of the air covers. This will loosen the exhaust cover (13) and o-ring (4) for removal.
7. Remove the diaphragm shaft u-cups (16) and pilot pin o-rings (1).
8. Inspect all parts for wear or damage, and replace as necessary.

Reassembly

1. Insert a diaphragm shaft u-cup (16*) and a pilot pin o-ring (1) into the end of the diaphragm shaft bore of the center housing (11).

NOTE: Make sure the lips of the u-cup face **out** of the center housing.

2. Line up the holes in the gasket (12) with the holes in the end of the center housing (11), and use six screws (141) to fasten an air cover (136) to the end of the center housing (11). Torque the screws to 35 to 45 in-lb (4.0 to 5.0 N-m).
3. Position the exhaust cover (13) and o-ring (4) on the center housing (11).
4. Repeat steps 1 and 2 for the other end of the center housing and the remaining air cover.
5. Apply medium-strength (blue) Loctite or equivalent to the threads of the screws (140). Install on one end of the diaphragm shaft (15) the following parts (see proper order in Fig. 10): air-side diaphragm plate (6), diaphragm (401), fluid-side diaphragm plate (133), o-ring (115), and screw (140).

NOTE: The words “AIR SIDE” on the diaphragm (401) and the flat side of the air-side diaphragm plate (6) must face toward the diaphragm shaft (15).

6. Put grease on the diaphragm shaft (15), and carefully (do not damage the shaft u-cups, 16) run the diaphragm shaft (15) through the center housing (11) bore.
7. Repeat step 5 for the other end of the diaphragm shaft (15), and torque the diaphragm shaft screws (140) to 80 to 90 in-lb (9 to 10 N-m) at 100 rpm maximum.
8. Apply thin, even film of grease to inside of vee clamp (109).
9. Position the fluid covers (101), install the vee clamps (109) around the fluid and air covers, install the grounding strip on the vee clamps, and torque the vee clamp nuts to 80 to 90 in-lb (9 to 10 N•m). See **Torque Sequence**, page 22.

When you install the vee clamps, orient the center housing (11) so the air inlet is approximately 45° above horizontal and the muffler (3) is approximately horizontal.

10. Make sure all the check valve parts are in place. See Fig. 9 on page 16.
11. Install the manifolds (102), and torque the manifold bolts (105) to 80 to 90 in-lb (9 to 10 N•m). See **Torque Sequence**, page 22.

Service

Diaphragms (Husky 716)

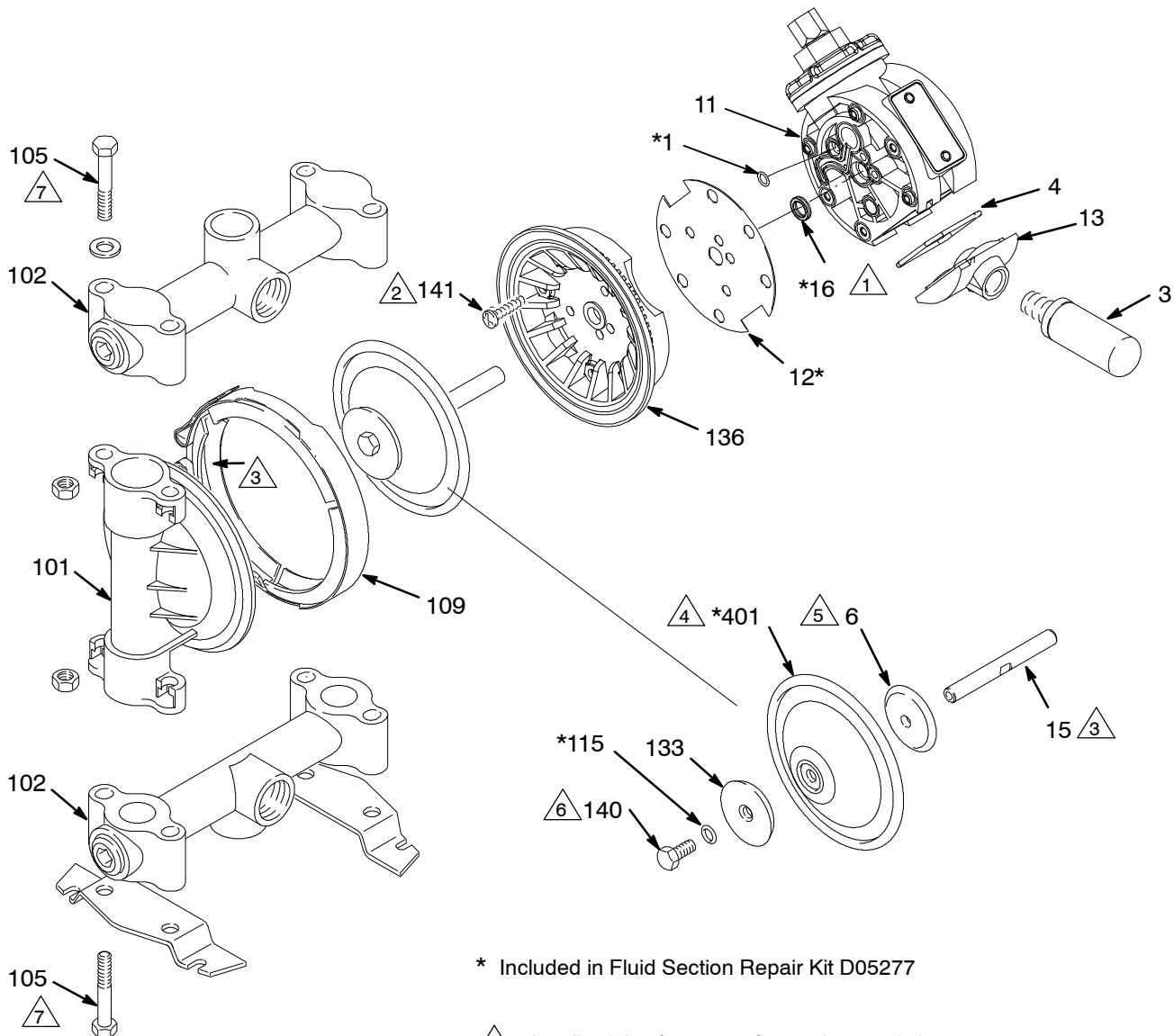

* Included in Fluid Section Repair Kit D05277

- 1 Install with lips facing out of center housing (11).
- 2 Torque to 35 to 45 in-lb (4.0 to 5.0 N·m).
- 3 Apply grease.
- 4 The words "AIR SIDE" on diaphragm and backup diaphragm must face toward diaphragm shaft (15).
- 5 Flat side of the air-side diaphragm plate must face toward diaphragm shaft (15).
- 6 Apply medium-strength (blue) Loctite® or equivalent to threads, and torque to 80 to 90 in-lb (9 to 10 N·m) at 100 rpm maximum.
- 7 Torque to 80 to 90 in-lb (9 to 10 N·m). See **Torque Sequence**, page 22.

Fig. 10

9271A

Parts

† Included in Air Valve Repair Kit 241657

* Included in Fluid Section Repair Kit D05277

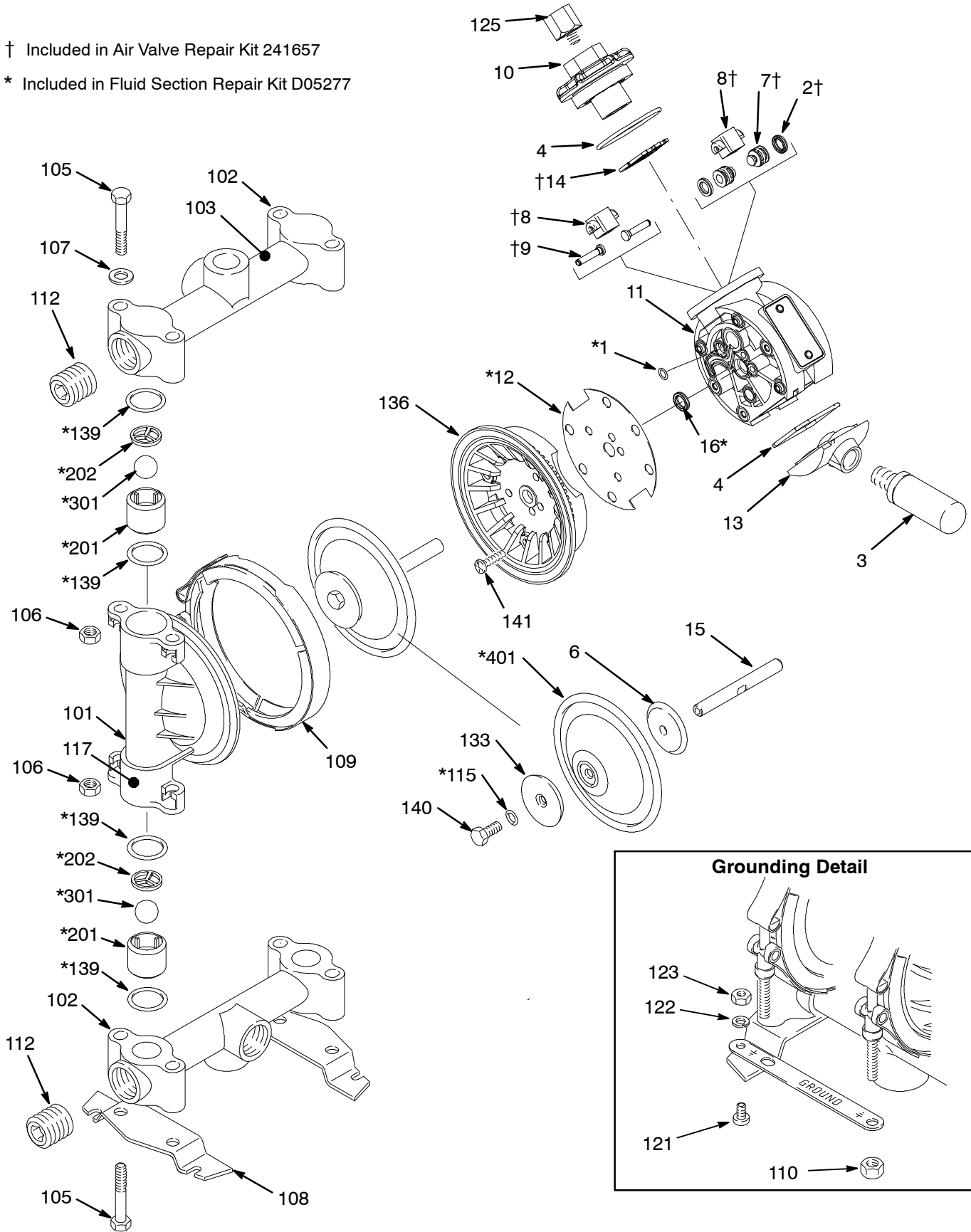

Parts

Ref. No.	Part No.	Description	Qty	Ref. No.	Part No.	Description	Qty
1*	114866	PACKING, o-ring	2	112	102726	PLUG, steel; 3/4 npt	2
2†	108808	PACKING, u-cup, carriage	2	115*	110004	O-RING; PTFE	2
3	112933	MUFFLER	1	117	186205	LABEL, warning	1
4†	162942	PACKING, o-ring	2	121	102790	SCREW; 10-24; 0.31 in. (8 mm)	1
6	195025	PLATE, diaphragm, air side	2	122	100718	LOCKWASHER; #10	1
7†	15Y825	PLUNGER, carriage	2	123	100179	NUT, hex; 10-24	1
8†	192595	CARRIAGE	2	133	191837	PLATE, diaphragm, fluid side; sst	2
9†	192596	PIN, carriage	2	125	238084	RESTRICTOR, air; brass with acetal restrictor	1
10	192597	COVER, valve chamber	1	134	100840	ELBOW, street; 1/4 npt x 1/4 npsm; for use in wall mount applications; not shown	1
11	192602	HOUSING, center	1	136	194246	COVER air	2
12*	192765	GASKET	2	139*	110636	O-RING; PTFE	8
13	194247	COVER, exhaust	1	140	113747	SCREW, flange; hex head	2
14†	194269	PLATE, valve	1	141	114882	SCREW, machine, phillips; pan head	12
15	192601	SHAFT, diaphragm	1	201*	186691	GUIDE; acetal	4
16*	108808	PACKING, u-cup, diaphragm	2	202*	186692	STOP; acetal	4
101	185622	COVER, fluid; aluminum	2	301*	108944	BALL; buna-N	4
102	185624	MANIFOLD; aluminum; NPT	2	401*	190148	DIAPHRAGM; buna-N	2
103	189220	LABEL, warning	1				
105	112912	SCREW; 3/8-16; 2.25 in. (57.2 mm)	8				
106	112913	NUT, hex; 3/8-16; sst	8				
107	112914	WASHER, flat; 3/8 in.; sst	4				
108	186207	BASE, feet	2				
109	189540	CLAMP, vee	2				
110	112499	NUT, clamp; 1/4-28	2				
111	191079	STRIP, grounding	1				

* These parts are included in Fluid Section Repair Kit D05277, which may be purchased separately.

† These parts are included in Air Valve Repair Kit 241657, which may be purchased separately.

▲ Replacement Danger and Warning labels, tags, and cards are available at no cost.

Torque Sequence

Always follow torque sequence when instructed to torque fasteners.

1. Left/Right Fluid Covers
Torque bolts to 80-90 in-lb (9-10 N•m)

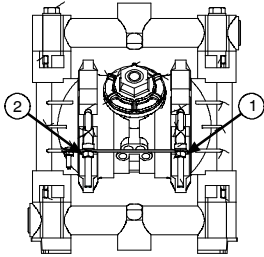

FRONT VIEW

3. Outlet Manifold
Torque Bolts to 80-90 in-lb (9-10 N•m)

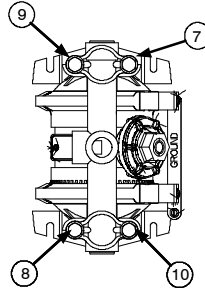

TOP VIEW

2. Inlet Manifold
Torque bolts to 80-90 in-lb (9-10 N•m)

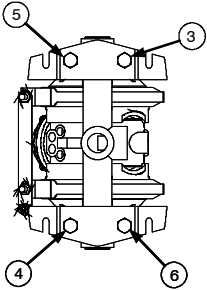

BOTTOM VIEW

Dimensions

FRONT VIEW

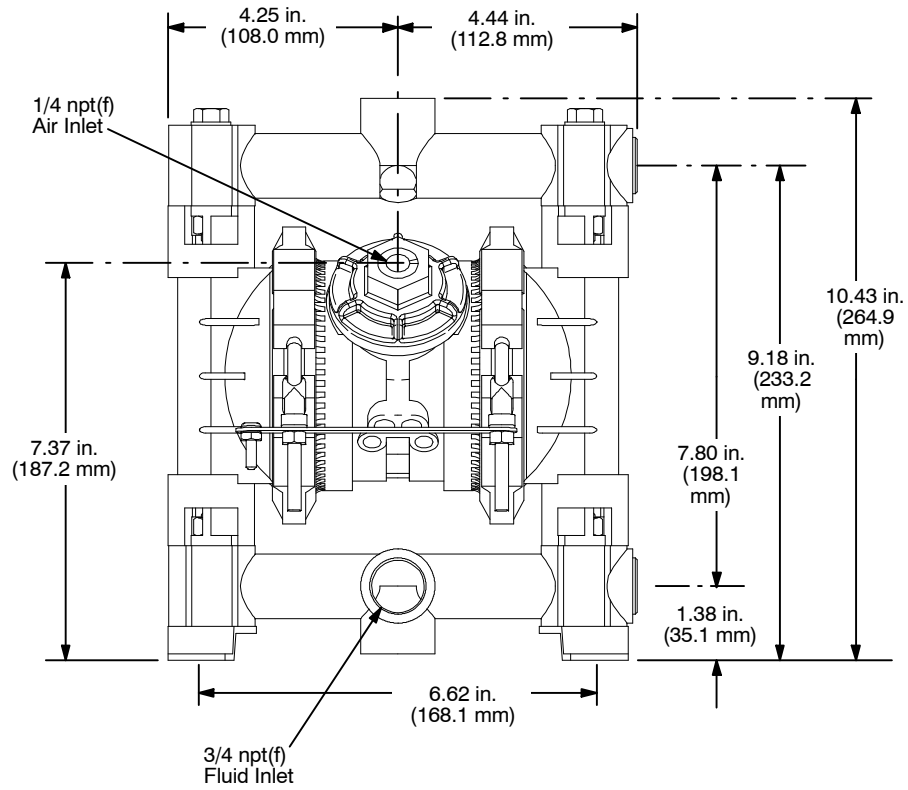

9257A

SIDE VIEW

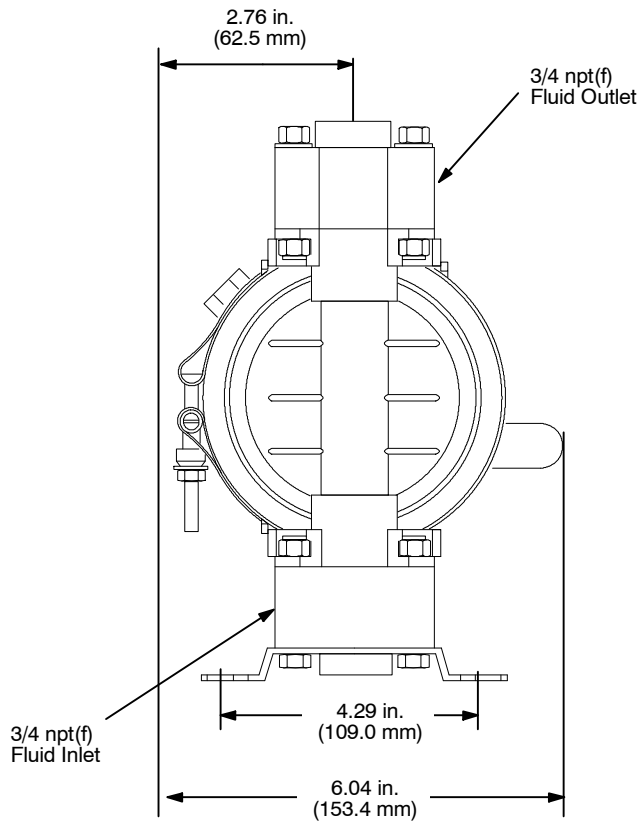

PUMP MOUNTING HOLE PATTERN

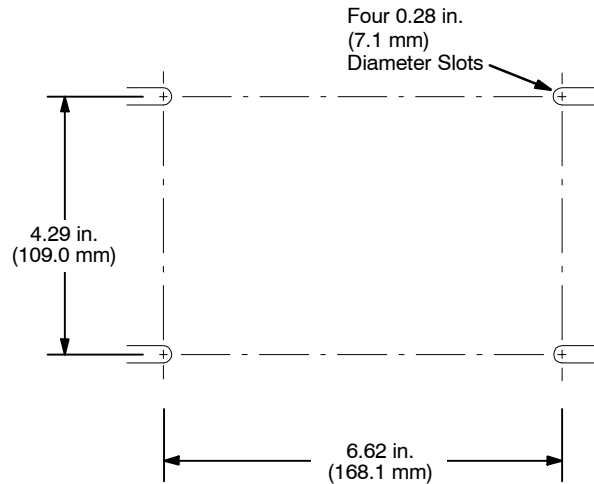

9254A

9078A

Technical Data

Maximum fluid working pressure	100 psi (0.7 MPa, 7 bar)
Air pressure operating range	25 to 100 psi (0.18 to 0.7 MPa, 1.8 to 7 bar)
Maximum air consumption*	28 scfm (0.672 cubic meters/min.)
Maximum free flow delivery*	16 gpm (61 l/min)
Maximum pump speed*	400 cpm
Gallons (Liters) per cycle	0.04(0.15)
Maximum suction lift (water w/buna balls)*	15 ft (4.5 m) dry, 25 ft (7.6 m) wet
Maximum size pumpable solids	3/32 in. (2.5 mm)
Sound power level (measured per ISO standard 9614-2)	
At 70 psig (0.48 MPa, 4.8 bar) at 50 cycles per minute	77 dBa
At 100 psig (0.7 MPa, 7 bar) at maximum cycles per minute	95 dBa
Sound pressure level (measured 1 meter from pump)	
At 70 psig (0.48 MPa, 4.8 bar) at 50 cycles per minute	67 dBa
At 100 psig (0.7 MPa, 7 bar) at maximum cycles per minute	85 dBa
Air inlet size	1/4 npt(f)
Air exhaust port size	3/8 npt(f)
Fluid inlet size	3/4 npt(f)
Fluid outlet size	3/4 npt(f)
Wetted parts	buna-N, acetal, aluminum, stainless steel, PTFE, zinc-plated steel
Non-wetted external parts	polypropylene, stainless steel, polyester (labels), nickel-plated brass, epoxy-coated steel (feet)
Weight (approximate)	8.5 lb (3.9 kg)

Loctite® is a registered trademark of the Loctite Corporation.

** Data given for pump with air inlet restrictor removed.*

Performance Charts

Fluid Outlet Pressure

Test Conditions: Pump tested in water with fluid inlet submerged and air inlet restrictor removed. For performance with air inlet restrictor in place, see manual 308589.

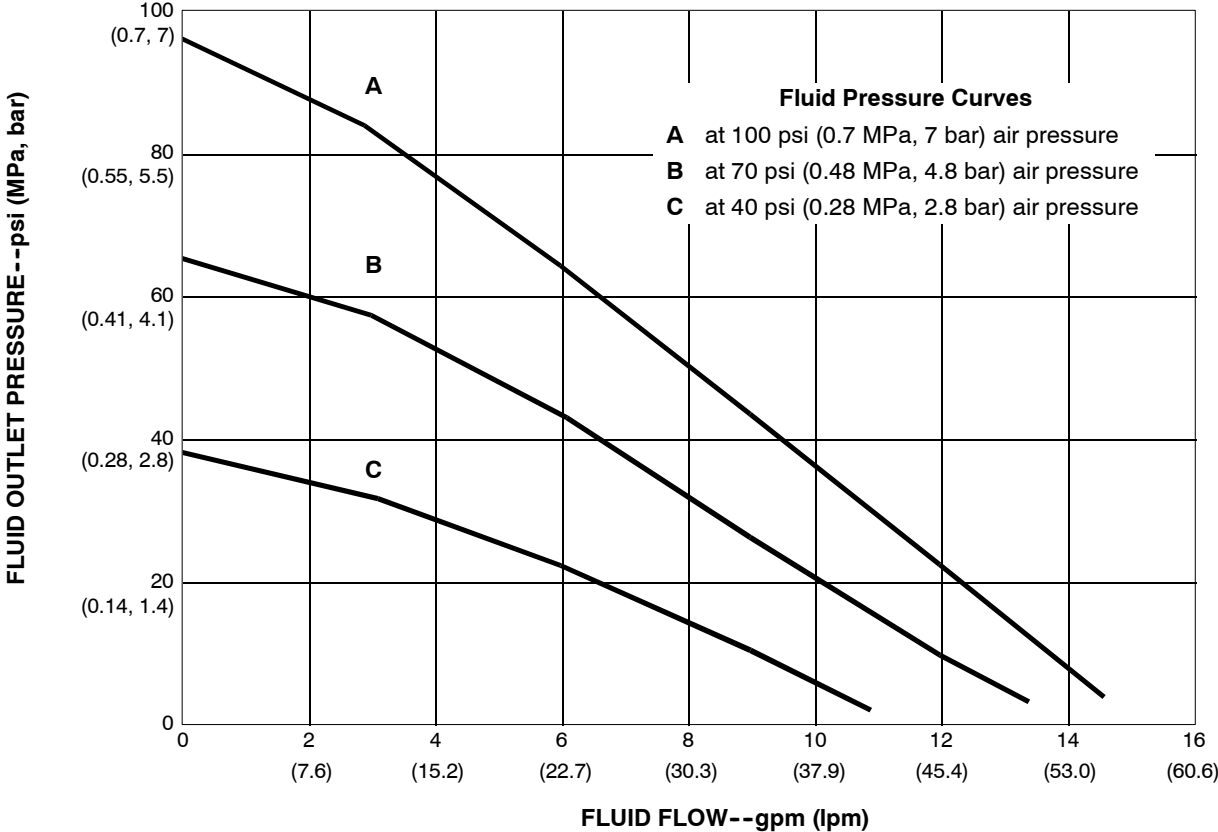

To find Fluid Outlet Pressure (psi/MPa/bar) at a specific fluid flow (gpm/lpm) and operating air pressure (psi/MPa/bar):

1. Locate fluid flow rate along bottom of chart.
2. Follow vertical line up to intersection with selected fluid outlet pressure curve.
3. Follow left to scale to read fluid outlet pressure.

Performance Charts

Air Consumption

Test Conditions: Pump tested in water with fluid inlet submerged and air inlet restrictor removed. For performance with air inlet restrictor in place, see manual 308589.

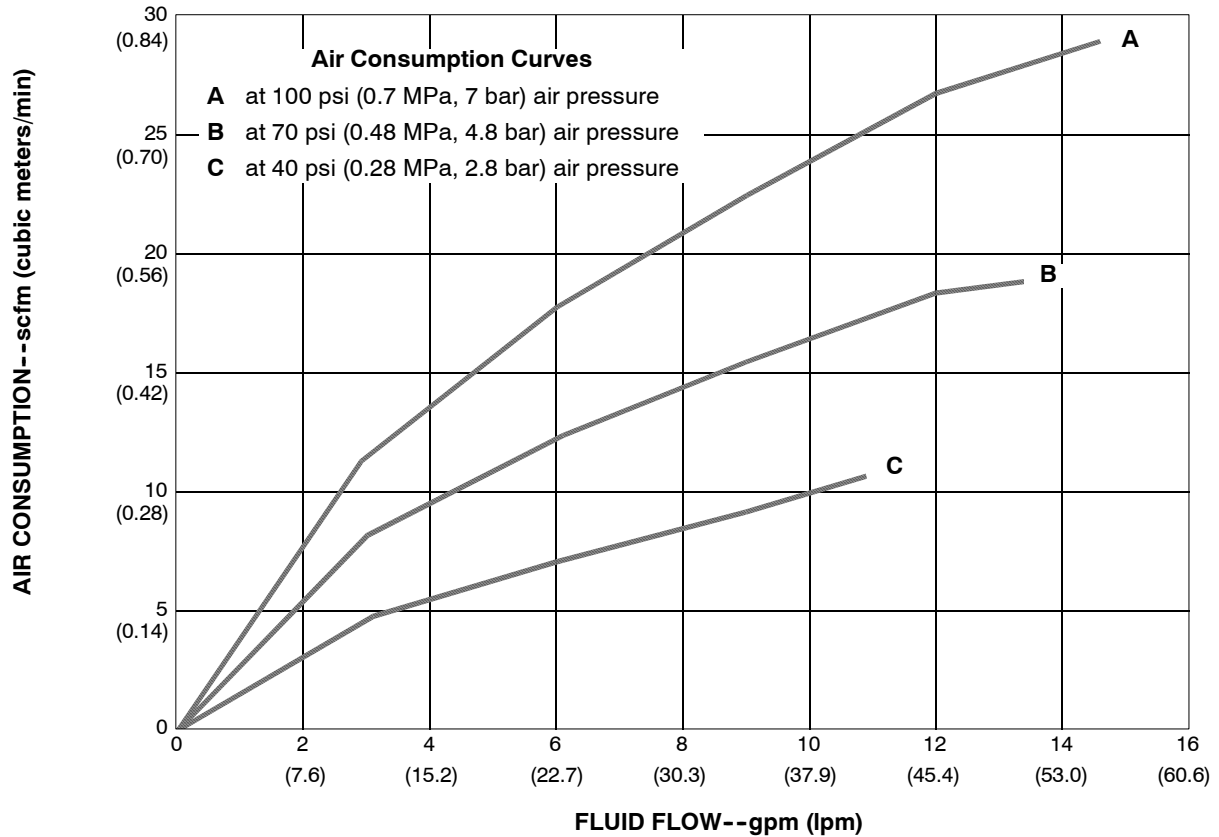

To find Pump Air Consumption (scfm or m³/min) at a specific fluid flow (gpm/lpm) and air pressure (psi/MPa/bar):

1. Locate fluid flow rate along bottom of chart.
2. Read vertical line up to intersection with selected air consumption curve.
3. Follow left to scale to read air consumption.

Graco Standard Husky Pump Warranty

Graco warrants all equipment referenced in this document which is manufactured by Graco and bearing its name to be free from defects in material and workmanship on the date of sale to the original purchaser for use. With the exception of any special, extended, or limited warranty published by Graco, Graco will, for a period of five years from the date of sale, repair or replace any part of the equipment determined by Graco to be defective. This warranty applies only when the equipment is installed, operated and maintained in accordance with Graco's written recommendations.

This warranty does not cover, and Graco shall not be liable for general wear and tear, or any malfunction, damage or wear caused by faulty installation, misapplication, abrasion, corrosion, inadequate or improper maintenance, negligence, accident, tampering, or substitution of non-Graco component parts. Nor shall Graco be liable for malfunction, damage or wear caused by the incompatibility of Graco equipment with structures, accessories, equipment or materials not supplied by Graco, or the improper design, manufacture, installation, operation or maintenance of structures, accessories, equipment or materials not supplied by Graco.

This warranty is conditioned upon the prepaid return of the equipment claimed to be defective to an authorized Graco distributor for verification of the claimed defect. If the claimed defect is verified, Graco will repair or replace free of charge any defective parts. The equipment will be returned to the original purchaser transportation prepaid. If inspection of the equipment does not disclose any defect in material or workmanship, repairs will be made at a reasonable charge, which charges may include the costs of parts, labor, and transportation.

THIS WARRANTY IS EXCLUSIVE, AND IS IN LIEU OF ANY OTHER WARRANTIES, EXPRESS OR IMPLIED, INCLUDING BUT NOT LIMITED TO WARRANTY OF MERCHANTABILITY OR WARRANTY OF FITNESS FOR A PARTICULAR PURPOSE.

Graco's sole obligation and buyer's sole remedy for any breach of warranty shall be as set forth above. The buyer agrees that no other remedy (including, but not limited to, incidental or consequential damages for lost profits, lost sales, injury to person or property, or any other incidental or consequential loss) shall be available. Any action for breach of warranty must be brought within six (6) years of the date of sale.

GRACO MAKES NO WARRANTY, AND DISCLAIMS ALL IMPLIED WARRANTIES OF MERCHANTABILITY AND FITNESS FOR A PARTICULAR PURPOSE, IN CONNECTION WITH ACCESSORIES, EQUIPMENT, MATERIALS OR COMPONENTS SOLD BUT NOT MANUFACTURED BY GRACO. These items sold, but not manufactured by Graco (such as electric motors, switches, hose, etc.), are subject to the warranty, if any, of their manufacturer. Graco will provide purchaser with reasonable assistance in making any claim for breach of these warranties.

In no event will Graco be liable for indirect, incidental, special or consequential damages resulting from Graco supplying equipment hereunder, or the furnishing, performance, or use of any products or other goods sold hereto, whether due to a breach of contract, breach of warranty, the negligence of Graco, or otherwise.

FOR GRACO CANADA CUSTOMERS

The Parties acknowledge that they have required that the present document, as well as all documents, notices and legal proceedings entered into, given or instituted pursuant hereto or relating directly or indirectly hereto, be drawn up in English. Les parties reconnaissent avoir convenu que la rédaction du présente document sera en Anglais, ainsi que tous documents, avis et procédures judiciaires exécutés, donnés ou intentés, à la suite de ou en rapport, directement ou indirectement, avec les procédures concernées.

Graco Information

For the latest information about Graco products, visit www.graco.com.

For patent information, see www.graco.com/patents.

TO PLACE AN ORDER, contact your Graco distributor or call to identify the distributor closest to you:

Phone: 612-623-6921 or **Toll Free:** 1-800-328-0211 **Fax:** 612-378-3505

All written and visual data contained in this document reflects the latest product information available at the time of publication. Graco reserves the right to make changes at any time without notice.

Original instructions. This manual contains English. MM 308573

Graco Headquarters: Minneapolis
International Offices: Belgium, China, Japan, Korea

GRACO INC. AND SUBSIDIARIES P.O. BOX 1441 MINNEAPOLIS, MN 55440-1441 USA
Copyright 1995, Graco Inc. All Graco manufacturing locations are registered to ISO 9001.

www.graco.com

Revision ZAB, January 2015