

XD40™ and XD50™ Hose Reels Repair

332203C

EN

Instructions for repairing hose reels used in applications requiring long range dispense, transfer or evacuation of motor oils, diesel fuels*, lubricants, water, waste oil and air.

Not for use with gasoline or other flammable fluids. Not approved for use in hazardous or explosive atmosphere locations. For professional use only.

**less than 20% biofuel content*

Models

(see page 3 for addition model information)

Spring Hose Reels

XD40 - Floor, Truck-bed or Overhead Mounted

XD50 - Floor or Truck-bed Mounted



Important Safety Instructions

Read all warnings and instructions in this manual and the XD40 and XD50 Operation Manual. Save these instructions.

Related Manual:

3A2990 - Installation and Operating Instructions

XD40

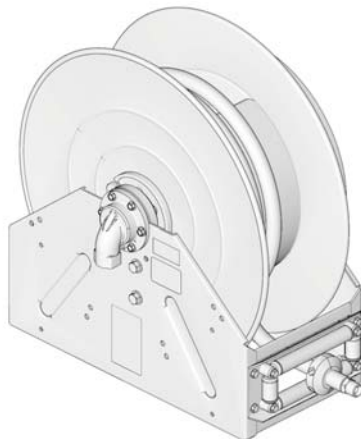

XD50

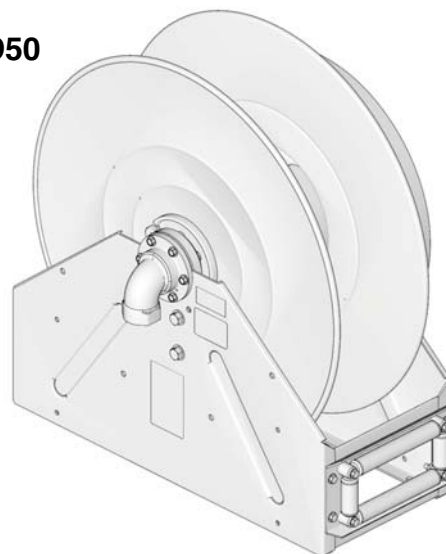

Table of Contents

Models	3	Table 1: Spring Tension Pre-turns	46
Warnings	7	Air / Water Models	46
General Repair Information	9	Oil Models	46
Bare Reels	9	Waste Oil Evacuation Models	46
Pressure Relief Procedure	9	Fuel Models	46
Grounding	9	Notes	47
Hose Reel Disassembly	10	Graco XD40/XD50 Hose Reel Warranty	48
Disconnecting inlet hose	10	Graco Information	48
Removing dispense valve and ball stop	10		
Flushing fluid from reel and hose	11		
Removing hose reel from service	11		
Removing spring canister	13		
Removing hose from spool	14		
Removing outlet	14		
Removing spring side bearing	14		
Removing inlet	14		
Removing spool from reel frame	15		
Removing inlet side bearings	15		
Removing ratchet	16		
Removing swivel	17		
Removing shaft	17		
Hose Reel Reassembly	18		
Swivel installation	18		
Ratchet installation	19		
Shaft installation	19		
Bearing installation	20		
Spool installation	21		
Inlet installation	22		
Spring side bearing installation	22		
Power spring canister installation	22		
Outlet installation	24		
Ball stop installation	25		
Additional Repair and Replacement Instructions 26			
Removing and Installing New Hose on Reel ...	26		
First Time Hose Installation	29		
Roller Guide Replacement	31		
Latch Replacement	33		
Adjusting Spring Tension	34		
Troubleshooting	38		
Parts Drawing	39		
XD40/XD50 Parts List	40		
Related Kits	42		
Technical Data	43		
Dimensions	44		
Mounting Hole Pattern	45		

Models

Understanding the Bare Reel Model Number

Bare reels are assigned a model number. This number identifies the frame size, port size, spring and pressure associated with that reel. For example an XD4010DLP model is an XD Model hose reel, size 40 frame, 1 inch port, D spring, low pressure.

- XD Frame Size: 40 or 50
- Port Size: 10 = 1 inch / 15 = 1.5 inch
- Spring Designation: A, B, C or D
- Pressure: LP - Low Pressure applications such as Air/Water, Fuel, and Waste Oil Evacuation typically under 300 psi (2.1 MPa, 21 bar) / MP - Medium Pressure applications such as Oil Dispense typically under 2000 psi (13.8 MPa, 138 bar)

XD40 Bare Reels

Bare Reel Model	NPT Models	BSPP Models	BSPT Models	Color	Spring	Maximum Working Pressure		
						PSI	MPa	bar
XD4010DLP	24P313	24P364	24P407	Blue	D	600	4.1	41
XD4010DLP	24P315	24P366	24P408	Yellow	D	600	4.1	41
XD4010DLP	24P316	24P367	24P409	White	D	600	4.1	41
XD4010CLP	24P317	24P368	24P410	Blue	C	600	4.1	41
XD4010CLP	24P318	24P369	24P411	Yellow	C	600	4.1	41
XD4010CLP	24P319	24P370	24P412	White	C	600	4.1	41
XD4010CMP	24P320	24P371	24P413	Blue	C	2000	13.8	138
XD4010CMP	24P322	24P372	24P414	Yellow	C	2000	13.8	138
XD4010CMP	24P323	24P373	24P415	White	C	2000	13.8	138
XD4010BMP	24R854	24R864	24R867	Blue	B	2000	13.8	138
XD4010BMP	24R855	24R865	24R868	Yellow	B	2000	13.8	138
XD4010BMP	24R856	24R866	24R869	White	B	2000	13.8	138
XD4010AMP	24P324	24P374	24P416	Blue	A	2000	13.8	138
XD4010AMP	24P325	24P375	24P417	Yellow	A	2000	13.8	138
XD4010AMP	24P326	24P376	24P418	White	A	2000	13.8	138

XD40 NPT, Reel with Hose - Air/Water

Bare Reel Model	Model	Color	Spring	Maximum Working Pressure			Hose Size
				PSI	MPa	bar	
XD4010DLP	24P327	Blue	D	300	2.1	21	1/2 inch x 100 ft.
XD4010DLP	24P328	Yellow	D	300	2.1	21	1/2 inch x 100 ft.
XD4010DLP	24P329	White	D	300	2.1	21	1/2 inch x 100 ft.
XD4010DLP	24P330	Blue	D	300	2.1	21	3/4 inch x 75 ft.
XD4010DLP	24P331	Yellow	D	300	2.1	21	3/4 inch x 75 ft.
XD4010DLP	24P332	White	D	300	2.1	21	3/4 inch x 75 ft.
XD4010CLP	24P333	Blue	C	300	2.1	21	3/4 inch x 100 ft.
XD4010CLP	24P334	Yellow	C	300	2.1	21	3/4 inch x 100 ft.
XD4010CLP	24P335	White	C	300	2.1	21	3/4 inch x 100 ft.
XD4010DLP	24P336	Blue	D	300	2.1	21	1 inch x 50 ft.
XD4010DLP	24P337	Yellow	D	300	2.1	21	1 inch x 50 ft.
XD4010DLP	24P338	White	D	300	2.1	21	1 inch x 50 ft.

XD40 NPT, Reel with Hose - Oil

Bare Reel Model	Model	Color	Maximum Working Pressure			Hose Size	Truck Mount Only
			PSI	MPa	bar		
XD4010AMP	24P339	Blue	2000	13.8	138	1/2 inch x 100 ft.	
XD4010AMP	24P340	Yellow	2000	13.8	138	1/2 inch x 100 ft.	
XD4010AMP	24P341	White	2000	13.8	138	1/2 inch x 100 ft.	
XD4010CMP	24P342	Blue	1530	10.5	105	3/4 inch x 75 ft.	X
XD4010CMP	24P343	Yellow	1530	10.5	105	3/4 inch x 75 ft.	X
XD4010CMP	24P344	White	1530	10.5	105	3/4 inch x 75 ft.	X
XD4010BMP	24R857	Blue	1530	10.5	105	3/4 inch x 75 ft.	
XD4010BMP	24R859	Yellow	1530	10.5	105	3/4 inch x 75 ft.	
XD4010BMP	24R860	White	1530	10.5	105	3/4 inch x 75 ft.	
XD4010AMP	24P345	Blue	1530	10.5	105	3/4 inch x 100 ft.	
XD4010AMP	24P346	Yellow	1530	10.5	105	3/4 inch x 100 ft.	
XD4010AMP	24P347	White	1530	10.5	105	3/4 inch x 100 ft.	
XD4010CMP	24P348	Blue	1275	8.79	88	1 inch x 50 ft.	X
XD4010CMP	24P349	Yellow	1275	8.79	88	1 inch x 50 ft.	X
XD4010CMP	24P350	White	1275	8.79	88	1 inch x 50 ft.	X
XD4010BMP	24R861	Blue	1275	8.79	88	1 inch x 50 ft.	
XD4010BMP	24R862	Yellow	1275	8.79	88	1 inch x 50 ft.	
XD4010BMP	24R863	White	1275	8.79	88	1 inch x 50 ft.	

XD40 NPT, Reel with Hose - Waste Oil Evacuation

Bare Reel Model	Model	Color	Maximum Working Pressure			Hose Size
			PSI	MPa	bar	
XD4010CLP	24P351	Blue	250	1.7	17	1 inch x 50 ft.
XD4010CLP	24P352	Yellow	250	1.7	17	1 inch x 50 ft.
XD4010CLP	24P353	White	250	1.7	17	1 inch x 50 ft.

XD40 NPT, Reel with Hose - Diesel Fuel

Bare Reel Model	Model	Color	Maximum Working Pressure			Hose Size
			PSI	MPa	bar	
XD4010CLP	24P354	Blue	250	1.7	17	1 inch x 50 ft.
XD4010CLP	24P355	Yellow	250	1.7	17	1 inch x 50 ft.
XD4010CLP	24P356	White	250	1.7	17	1 inch x 50 ft.

XD50 Bare Reels

Bare Reel Model	NPT Models	BSPP Models	BSPT Models	Color	Spring	Porting Size (Inches)	Maximum Working Pressure		
							PSI	MPa	bar
XD5010ALP	24P455	24P500	24P549	Blue	A	1	600	4.1	41
XD5010ALP	24P456	24P503	24P550	Yellow	A	1	600	4.1	41
XD5010ALP	24P457	24P504	24P551	White	A	1	600	4.1	41
XD5015BLP	24P461	24P508	24P555	Blue	B	1.5	600	4.1	41
XD5015BLP	24P462	24P509	24P556	Yellow	B	1.5	600	4.1	41
XD5015BLP	24P463	24P510	24P558	White	B	1.5	600	4.1	41
XD5010BLP	24P464	24P511	24P559	Blue	B	1	600	4.1	41
XD5010BLP	24P465	24P512	24P560	Yellow	B	1	600	4.1	41
XD5010BLP	24P466	24P513	24P561	White	B	1	600	4.1	41
XD5015ALP	24P467	24P514	24P563	Blue	A	1.5	600	4.1	41
XD5015ALP	24P468	24P515	24P564	Yellow	A	1.5	600	4.1	41
XD5015ALP	24P469	24P516	24P565	White	A	1.5	600	4.1	41
XD5010AMP	24P458	24P505	24P552	Blue	A	1	2000	13.8	138
XD5010AMP	24P459	24P506	24P553	Yellow	A	1	2000	13.8	138
XD5010AMP	24P460	24P507	24P554	White	A	1	2000	13.8	138

XD50 NPT, Reel with Hose - Air/Water

Bare Reel Model	Model	Color	Spring	Maximum Working Pressure			Hose Size
				PSI	MPa	bar	
XD5010ALP	24P470	Blue	A	300	2.1	21	1 inch x 75 ft.
XD5010ALP	24P471	Yellow	A	300	2.1	21	1 inch x 75 ft.
XD5010ALP	24P472	White	A	300	2.1	21	1 inch x 75 ft.
XD5010ALP	24P473	Blue	A	300	2.1	21	1 inch x 100 ft.
XD5010ALP	24P474	Yellow	A	300	2.1	21	1 inch x 100 ft.
XD5010ALP	24P475	White	A	300	2.1	21	1 inch x 100 ft.

XD50 NPT, Reel with Hose - Oil

Bare Reel Model	Model	Color	Spring	Maximum Working Pressure			Hose Size
				PSI	MPa	bar	
XD5010AMP	24P476	Blue	A	1275	8.79	88	1 inch x 75 ft.
XD5010AMP	24P477	Yellow	A	1275	8.79	88	1 inch x 75 ft.
XD5010AMP	24P478	White	A	1275	8.79	88	1 inch x 75 ft.

XD50 NPT, Reel with Hose - Waste Oil Evacuation



Bare Reel Model	Model	Color	Spring	Maximum Working Pressure			Hose Size
				PSI	MPa	bar	
XD5015BLP	24P479	Blue	B	200	1.4	14	1.25 inch x 35 ft.
XD5015BLP	24P480	Yellow	B	200	1.4	14	1.25 inch x 35 ft.
XD5015BLP	24P481	White	B	200	1.4	14	1.25 inch x 35 ft.
XD5015BLP	24P482	Blue	B	200	1.4	14	1.25 inch x 50 ft.
XD5015BLP	24P483	Yellow	B	200	1.4	14	1.25 inch x 50 ft.
XD5015BLP	24P484	White	B	200	1.4	14	1.25 inch x 50 ft.

XD50 NPT, Reel with Hose - Diesel Fuel





Bare Reel Model	Model	Color	Spring	Maximum Working Pressure			Hose Size
				PSI	MPa	bar	
XD5010BLP	24P485	Blue	B	250	1.7	17	1 inch x 75 ft.
XD5010BLP	24P486	Yellow	B	250	1.7	17	1 inch x 75 ft.
XD5010BLP	24P487	White	B	250	1.7	17	1 inch x 75 ft.
XD5010ALP	24P488	Blue	A	250	1.7	17	1 inch x 100 ft.
XD5010ALP	24P489	Yellow	A	250	1.7	17	1 inch x 100 ft.
XD5010ALP	24P490	White	A	250	1.7	17	1 inch x 100 ft.
XD5015BLP	24P491	Blue	B	250	1.7	17	1.25 inch x 35 ft.
XD5015BLP	24P492	Yellow	B	250	1.7	17	1.25 inch x 35 ft.
XD5015BLP	24P493	White	B	250	1.7	17	1.25 inch x 35 ft.
XD5015BLP	24P494	Blue	B	250	1.7	17	1.25 inch x 50 ft.
XD5015BLP	24P495	Yellow	B	250	1.7	17	1.25 inch x 50 ft.
XD5015BLP	24P496	White	B	250	1.7	17	1.25 inch x 50 ft.
XD5015ALP	24P497	Blue	A	150	1.0	10	1.5 inch x 50 ft.
XD5015ALP	24P498	Yellow	A	150	1.0	10	1.5 inch x 50 ft.
XD5015ALP	24P499	White	A	150	1.0	10	1.5 inch x 50 ft.

Warnings

The following warnings are for the setup, use, grounding, maintenance, and repair of this equipment. The exclamation point symbol alerts you to a general warning and the hazard symbols refer to procedure-specific risks. When these symbols appear in the body of this manual or on warning labels, refer back to these Warnings. Product-specific hazard symbols and warnings not covered in this section may appear throughout the body of this manual where applicable.

 WARNING	
	<p>FIRE AND EXPLOSION HAZARD</p> <p>When flammable fluids are present in the work area, such as gasoline and windshield wiper fluid, be aware that flammable fumes can ignite or explode. To help prevent fire and explosion:</p> <ul style="list-style-type: none"> • Use equipment only in well ventilated area. • Eliminate all ignition sources, such as cigarettes and portable electric lamps. • Keep work area free of debris, including rags and spilled or open containers of solvent and gasoline. • Do not plug or unplug power cords or turn lights on or off when flammable fumes are present. • Ground all equipment in the work area. • Only use hoses that are compatible with the fluid you are dispensing. • Stop operation immediately if static sparking occurs or you feel a shock. Do not use equipment until you identify and correct the problem. • Keep a working fire extinguisher in the work area.
	<p>SKIN INJECTION HAZARD</p> <p>High-pressure fluid from dispensing device, hose leaks, or ruptured components will pierce skin. This may look like just a cut, but it is a serious injury that can result in amputation. Get immediate surgical treatment.</p> <ul style="list-style-type: none"> • Do not point dispensing device at anyone or at any part of the body. • Do not put your hand over the fluid outlet. • Do not stop or deflect leaks with your hand, body, glove, or rag. • Follow the Pressure Relief Procedure when you stop dispensing and before cleaning, checking, or servicing equipment. • Tighten all fluid connections before operating the equipment. • Check hoses and couplings daily. Replace worn or damaged parts immediately.

! WARNING

	<p>EQUIPMENT MISUSE HAZARD</p> <p>Misuse can cause death or serious injury.</p> <ul style="list-style-type: none"> • Do not operate the unit when fatigued or under the influence of drugs or alcohol. • Do not exceed the maximum working pressure or temperature rating of the lowest rated system component. See Technical Data in all equipment manuals. • Use fluids and solvents that are compatible with equipment wetted parts. See Technical Data in all equipment manuals. Read fluid and solvent manufacturer's warnings. For complete information about your material, request MSDS from distributor or retailer. • Do not leave the work area while equipment is energized or under pressure. • Turn off all equipment and follow the Pressure Relief Procedure when equipment is not in use. • Check equipment daily. Repair or replace worn or damaged parts immediately with genuine manufacturer's replacement parts only. • Do not alter or modify equipment. Alterations or modifications may void agency approvals and create safety hazards. • Make sure all equipment is rated and approved for the environment in which you are using it. • Use equipment only for its intended purpose. Call your distributor for information. • Route hoses and cables away from traffic areas, sharp edges, moving parts, and hot surfaces. • Do not kink or over bend hoses or use hoses to pull equipment. • Keep children and animals away from work area. • Comply with all applicable safety regulations.
	<p>MOVING PARTS HAZARD</p> <p>Moving parts can pinch, cut or amputate fingers and other body parts.</p> <ul style="list-style-type: none"> • Keep clear of moving parts. • Do not operate equipment with protective guards or covers removed. • Pressurized equipment can start without warning. Before checking, moving, or servicing equipment, follow the Pressure Relief Procedure and disconnect all power sources.
	<p>TOXIC FLUID OR FUMES HAZARD</p> <p>Toxic fluids or fumes can cause serious injury or death if splashed in the eyes or on skin, inhaled, or swallowed.</p> <ul style="list-style-type: none"> • Read MSDSs to know the specific hazards of the fluids you are using. • Store hazardous fluid in approved containers, and dispose of it according to applicable guidelines.
	<p>PERSONAL PROTECTIVE EQUIPMENT</p> <p>Wear appropriate protective equipment when in the work area to help prevent serious injury, including eye injury, hearing loss, inhalation of toxic fumes, and burns. This protective equipment includes but is not limited to:</p> <ul style="list-style-type: none"> • Protective eyewear, and hearing protection. • Respirators, protective clothing, and gloves as recommended by the fluid and solvent manufacturer

General Repair Information

- Always use all the new parts included in repair kit. Do not reuse old parts.
- Unless otherwise indicated, reference numbers used in the following instructions refer to the Parts Drawing on page 39 and the Parts List beginning on page 39.
- See Related Kits (page 42) or contact Graco Customer Service to identify the kit needed for your repair.
- All instructions assume the hose reel has been installed and is in service.

Bare Reels

Instructions for bare reels are included in the XD40 and XD50 Hose Reels Installation and Operation instruction manual provided with your hose reel and on Graco.com.

Pressure Relief Procedure



Follow the Pressure Relief Procedure whenever you see this symbol.



This equipment stays pressurized until pressure is manually relieved. To help prevent serious injury from pressurized fluid, such as skin injection, splashing fluid and moving parts, follow the Pressure Relief Procedure when you stop spraying and before cleaning, checking, or servicing the equipment.

1. Turn off power supply to fluid pump.
2. Isolate the supply pump fluid supply line.
3. Open the dispensing valve until pressure is fully relieved.

If you suspect the dispensing valve or extension is clogged or that pressure has not been fully relieved after following the steps above, **VERY SLOWLY** loosen coupler or hose end coupling to relieve pressure gradually, then loosen completely. Clear the obstruction.

Grounding

<p>The equipment must be bonded (grounded) to the truck. Grounding reduces the risk of static shock due to static build up on the equipment. Refer to your pump instruction manual for grounding instructions.</p>						

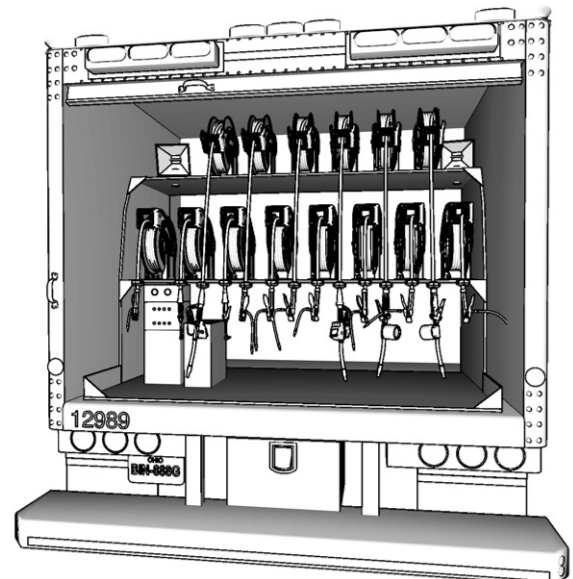

FIG. 1

Hose Reel Disassembly

--	--	--	--	--	--	--

- Always wear heavy, non-slippery gloves to protect your hands from being cut on the hose reel.
- Never allow the reel to spin freely. Doing so causes the spool to spin out of control, which could cause serious injury if you are hit by the hose or dispense valve.

NOTE:

- Throughout these instructions the inlet-side refers to the side of the spool the fluid inlet (6) is installed. The spring-side refers to the side of the spool the spring (10) is installed.
- Additional procedures are provided at the end of the Hose Reel Disassembly section of this manual.

--	--	--	--	--	--	--

1. **Relieve pressure, page 9.**
2. **Disconnect inlet hose (a) from inlet (6).**

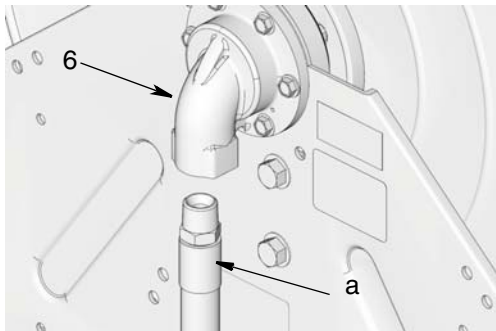

FIG. 2

3. **Pull out enough hose to perform flushing procedure (Step 7, page 11).**

4. Engage latch.

Securely attach a c-clamp (A) to the reel spool abutting frame, as shown in FIG. 3, to help prevent the reel from unintentionally becoming unlatched and spinning freely.

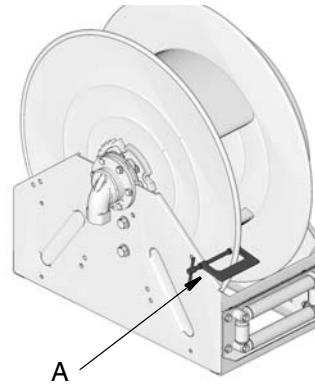

FIG. 3

5. Remove dispense valve and ball stop.

To remove ball stop: remove nuts (47), screws (46) and ball stop (45) from end of hose (FIG. 4).

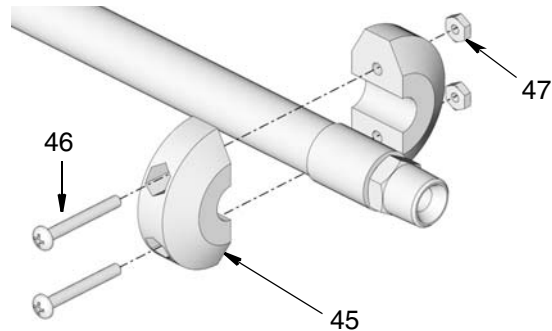

FIG. 4

If you are only replacing the ball stop, stop disassembly instructions here.

Ball Stop Kits: 218341, 222225, 237872, 24R060, 24R061 are available from Graco. Ball stop reassembly instructions are provided in Step 14, page 25.

6. If you are not replacing the ball stop, set these pieces aside to use for reassembly.



7. Flush fluid from reel and hose.

- a. Place end of hose in a waste container.



FIG. 5

- b. Blow out entire lubricant supply line with air.

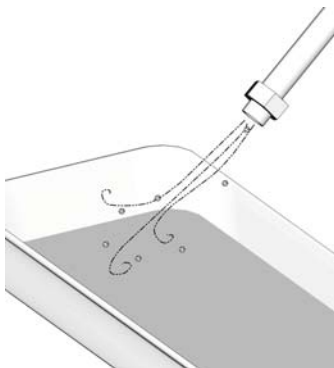

FIG. 6

- c. Cap end of hose to prevent fluid spills.

8. Remove Hose Reel From Service.

The hose reel must be taken out of service to perform some of the repair and service procedures described in this manual.

Refer the following Procedures Table to identify which procedures do not require the hose reel be taken out of service before you perform the repair or maintenance procedure and those that do require the hose reel be taken out of service.

For procedures that do not require the hose reel is taken out of service, skip Step 8a - b and continue hose reel disassembly instructions with Step 9, page 12.

Procedure Table

Procedure	Un-install Reel	Reel Installed
Remove dispense valve and ball stop		X
Add/Remove spring tension		X
Remove /Replace spring canister	X	
Remove/Replace outlet and seals		X
Remove/Replace inlet and seals		X
Remove/Replace bearings	X	
Remove/Replace ratchet	X	
Remove spool from frame	X	
Remove shaft from spool	X	
Remove/Replace hose		X
Replacing roller guide		X
Replace latch		X

- a. Unbolt reel and remove it from mounting location.

NOTE: For overhead installations always use a hoist or other suitable lifting device to raise or lower hose reel position.

Secure a lifting strap around spool as shown in FIG. 7. See Technical Data (page 43) for hose reel weights.

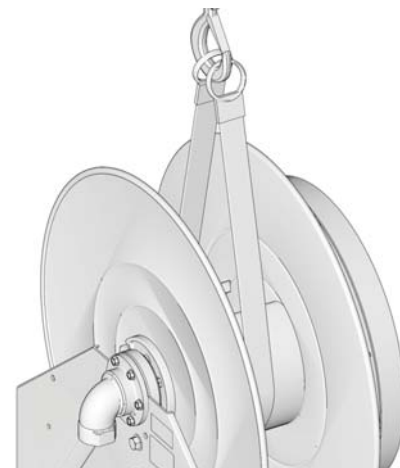

FIG. 7

- b. Use 2, large c-clamps (B) to secure the hose reel to a flat surface (FIG. 8).

NOTE: Graco recommends placing a rag over the bottom roller and the back frame to protect these surfaces from damage when the c-clamps are tightened down.

NOTICE

The front c-clamp should only be tightened enough to prevent the reel from moving. Overtightening this clamp could damage the bottom roller.

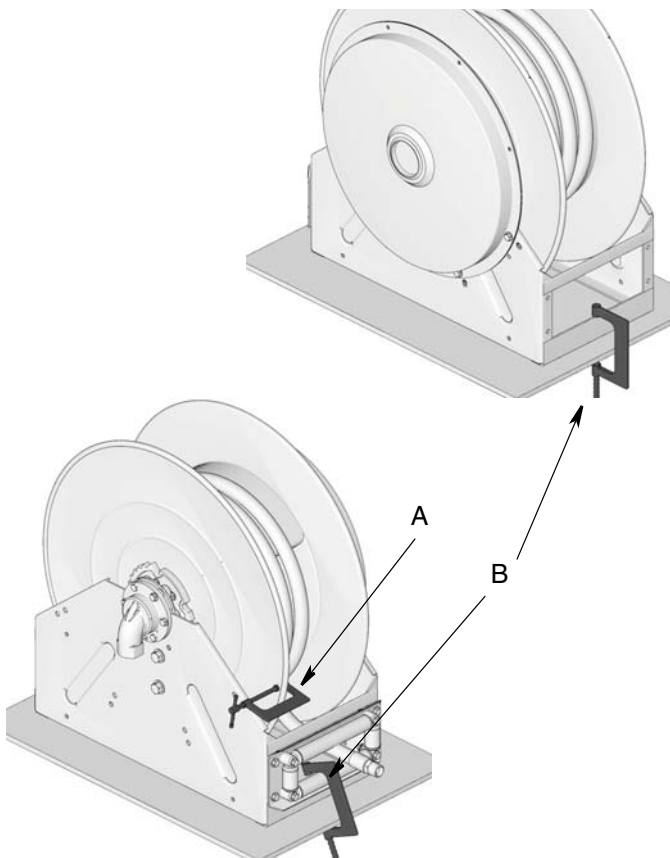

FIG. 8

9. Unwind reel to remove spring tension before beginning disassembly.

<ul style="list-style-type: none"> Always wear heavy, non-slippery gloves to protect your hands from being cut on the hose reel. Never allow the reel to spin freely. Doing so causes the spool to spin out of control, which could cause serious injury if you are hit by the hose or dispense valve. 						

- a. Verify the ratchet and latch are still engaged and the c-clamp is still installed.
- b. Feed the loose end of hose through the hose rollers and manually wrap hose and secure the hose to reel spool (FIG. 9).

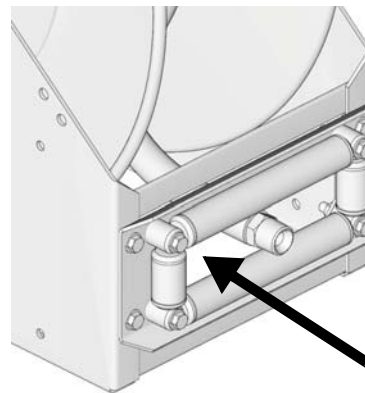

FIG. 9



- c. Place a piece of tape on the side of reel flange as a visual reference point for counting reel rotations.
- d. Remove c-clamp (A).
- e. Rotate spool in the tightening direction to disengage latch.
- f. Use your hands to unwind reel by rotating the spool in the opposite direction turned to add spring tension, until it the reel reaches a free state.

NOTE: Count the number of turns while unwinding the spool and record the number for use when tensioning the spring later.

10. Remove spring canister from reel.

NOTE: The power spring typically doesn't need to be replaced unless it is broken. Verify the spring is broken by confirming the absence of any spring tension. If there is still tension on the spring and you have determined it is not broken, the spring canister can be reused for reassembly.

The hose reel *MUST* be taken out of service for this procedure.

					
<p>HOSE REEL SPRING HAZARD</p> <p>Do not attempt to service the spring inside of the spring canister. It is under extreme tension, even if the spring is broken, and could be propelled out of the opened canister and cause serious injury. The only service you should perform on the reel spring is replacement of the spring canister.</p>					

- a. Insert a flat screwdriver blade into the plastic end cap (32) and pry it off the spring canister (10) (FIG. 10). Discard end cap, it cannot be reused.

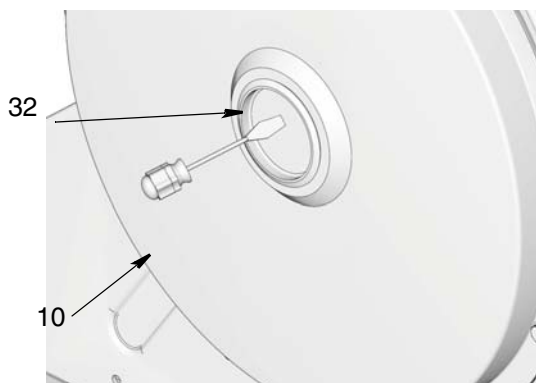

FIG. 10

- b. Remove all bolts (9) from the spring canister (10).

NOTE: Remove the bottom two bolts (9a and 9b) first. Then use your free hand to support the spring while removing the other two bolts 9c and 9d (FIG. 11).

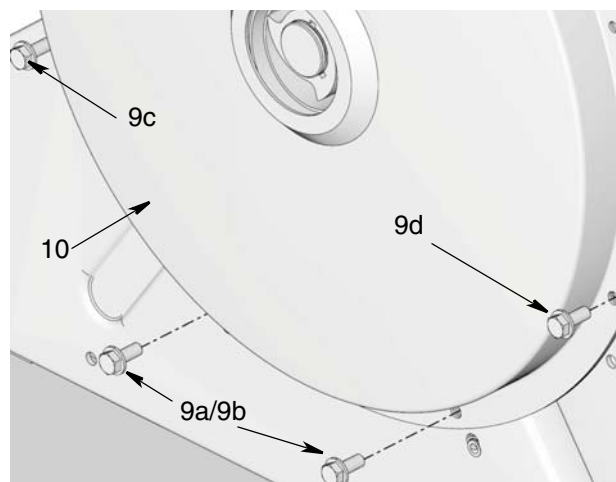

FIG. 11

- c. Remove the spring canister (10) from the spool. If you are not replacing the canister, lift canister slightly to clear hub (13) and set canister aside for reassembly. If you are replacing the spring canister, discard canister.
- d. Use a snap ring pliers to remove snap ring (14) (FIG. 12).

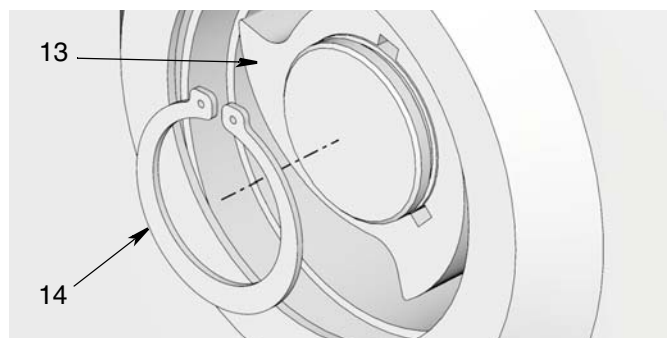

FIG. 12

- e. Remove hub (13) and key (12) (FIG. 12).

If you are only replacing the Power Spring, stop disassembly instructions here.

Power Spring Kits: 24R062, 24R063, 24R064, 24R065 are available from Graco. Power Spring reassembly instructions begin with Step 11 page 22.

11. If you are not replacing the power spring, set the spring canister aside to use for reassembly.

12. Unwind reel to remove hose from spool.

NOTE:

- Because the spring is no longer installed on the reel, the hose should pull off the reel very easily.
 - In some procedures you do not have to remove the spring before taking the hose off the reel. Hose removal instructions when the spring is installed on the reel are provided on page 26.
13. Remove bolts (37) and outlet (30) from spool (FIG. 13).

NOTE:

- The hose does not have to be removed from the outlet unless you are replacing the hose. Hose replacement instructions are provided in Removing and Installing New Hose on Reel on page 26.

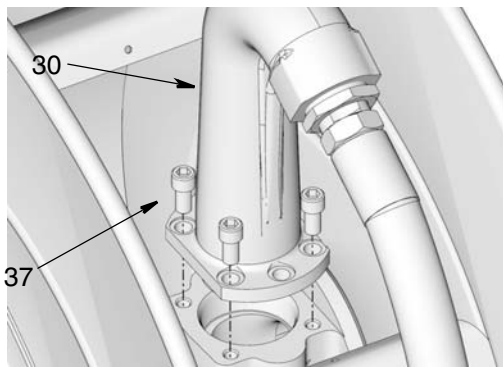

FIG. 13

- The outlet (30) will not fit through the roller guides. Pull the dispense end of the hose through the rollers as shown in FIG. 14 to remove hose from the reel.

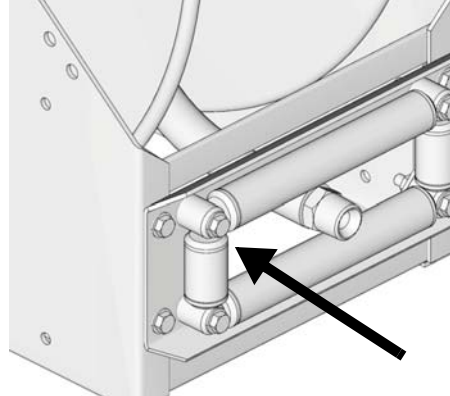

FIG. 14

14. Remove spring side bearing retainer (7), spacers (15) and bearing (8).

- a. Remove nuts (38) (FIG. 15).

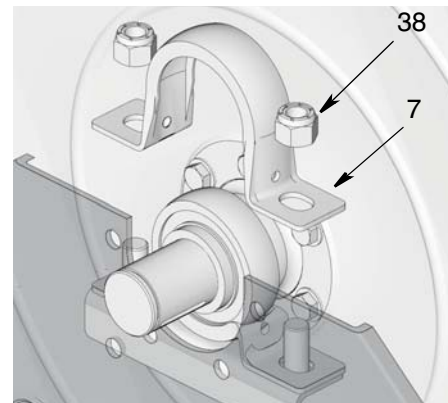

FIG. 15

- b. Insert a flat blade screw driver under the retainer (7) to pry it up and remove it (FIG. 15).
- c. Remove spacers (15) and bearing (8).
15. If you are not replacing these parts, set them aside for use for reassembly.

16. Remove inlet (6) .

NOTE: Notice the position of the inlet to ensure correct orientation of this part for reassembly.

- a. Medium Pressure Models ONLY: On the inlet side, remove bolts (4), inlet (6) and shim (36) (FIG. 16).

NOTE: Do not lose the shim (36). You will need it for reassembly.

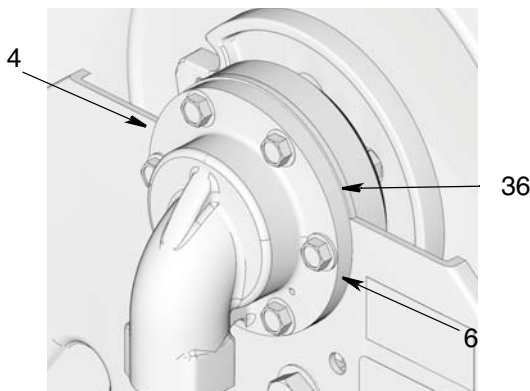

FIG. 16

If you are only replacing the Inlet and/or Inlet Seals, stop disassembly instructions here.

Inlet Kits: 24R067, 24R068, 24R074, 24R075, 24R677, and 24R678 are available from Graco. Inlet reassembly instructions begin with Step 9 page 22.

- 17. If you are not replacing these parts, set them aside for use for reassembly.

- 18. Lift up spool (2) to remove it from base (1) (FIG. 17).

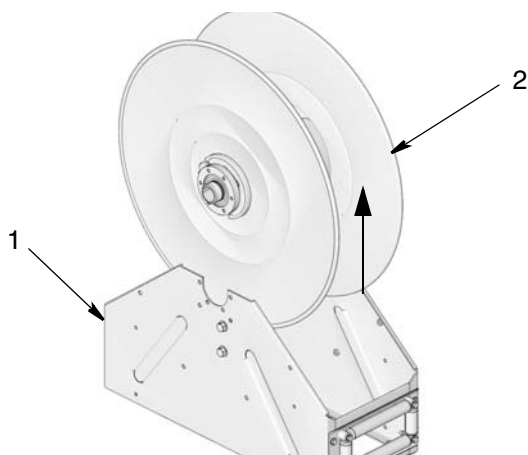

FIG. 17

- 19. Lay spool (2) on it's side on a clean, sturdy work surface.

20. Remove Inlet Side Bearings.

NOTE: Separate instructions are provided for Medium Pressure Hose Reels and Low Pressure Hose Reels (depending on your hose reel model). Medium Pressure Hose Reel instructions begin below, Low Pressure instructions begin on page 16.

Medium Pressure Hose Reels Inlet Side Bearing Removal

- a. Use a snap ring pliers to remove snap ring (41) (FIG. 18).

NOTICE
Be careful not to scratch or score the surface of the (a) when using the snap ring pliers to remove the snap ring (41). Damage to this surface could result in fluid leakage. Protect the surface by wrapping it with black electric tape.

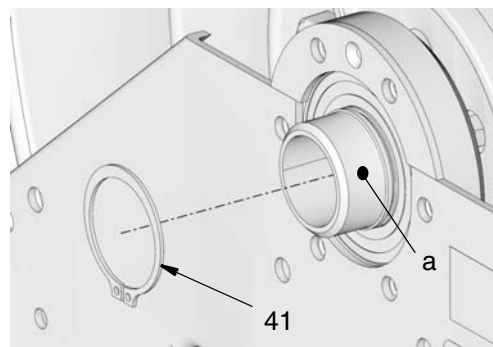

FIG. 18

- b. Use a spanner wrench to remove bearing retainer (42) nut. Once it is loose you can use your hand to unscrew and remove it (FIG. 19).

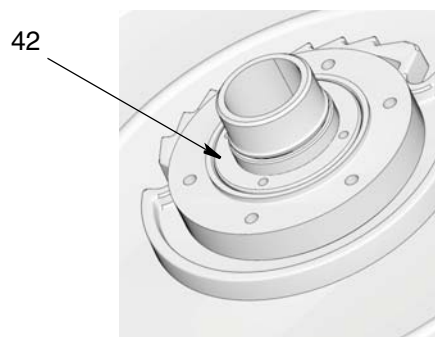

FIG. 19

- c. Remove bearing retainer (5).

NOTE: Be careful when you remove the bearing retainer (5) that the bearing balls (35) do not fall out (FIG. 20).

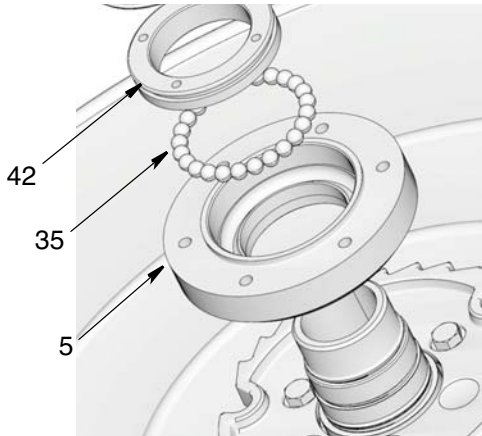

FIG. 20

If you are only replacing the Medium Pressure Bearing, stop disassembly instructions here.

Medium Pressure Bearing Kit: 24R071 is available from Graco. Reassembly instructions begin with Step 5b page 20.

- d. If you are not replacing the Medium Pressure bearing, set these parts aside to use for reassembly.

Low Pressure Hose Reels Inlet Side Bearing Removal

- a. Use a snap ring pliers to remove snap ring (41) (FIG. 21).

NOTICE

Be careful not to scratch or score the surface of the (a) when using the snap ring pliers to remove the snap ring (41). Damage to this surface could result in fluid leakage. Protect the surface by wrapping it with black electric tape.

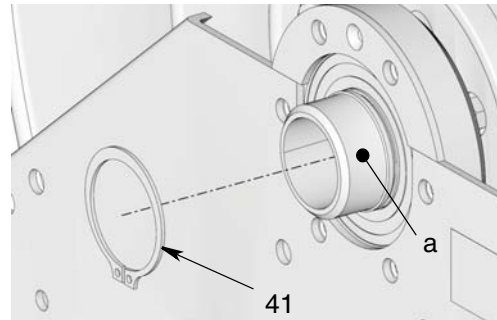

FIG. 21

- b. Slide bearing seal and retainer assembly (49) off shaft (FIG. 22).

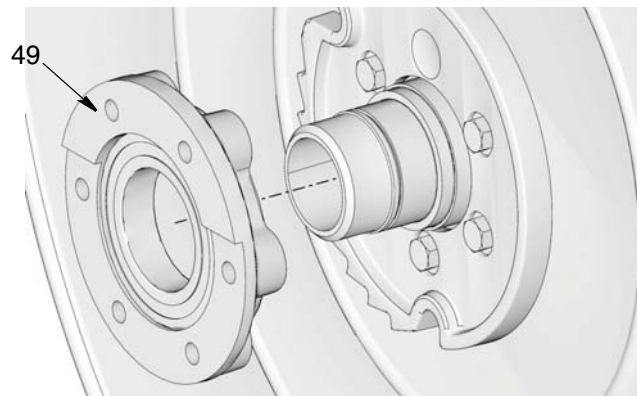

FIG. 22

If you are only replacing the Low Pressure Bearing, stop disassembly instructions here.

Low Pressure Bearing Kit: 24R070 is available from Graco. Reassembly instructions begin with Step 5b page 20.

- c. If you are not replacing the low pressure bearing, set these parts aside to use for reassembly.

21. Remove bolts (4) holding ratchet (31) to spool (FIG. 23).

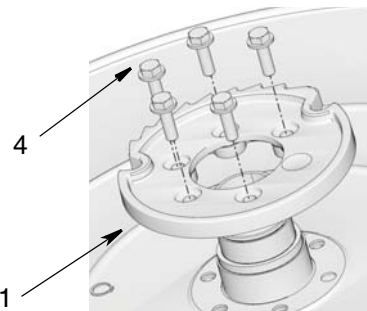

FIG. 23

NOTE: Place a piece of tape as a marker at the location of the non-threaded hole (a) that does not have a screw, located on the inlet side of the spool, to ensure the inlet is reinstalled on the correct side and in the correct position during reassembly.

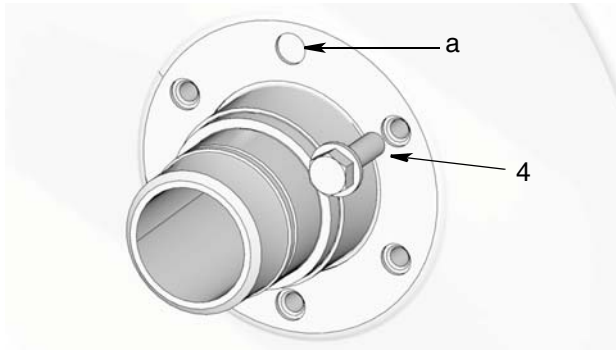

FIG. 24

If you are only replacing the Ratchet, stop disassembly instructions here.

Ratchet Kit 24R338 is available from Graco. If you are only replacing the Ratchet, stop disassembly instructions here. Reassembly instructions are provided in Step 2, page 19.

If you are not replacing the ratchet, set these parts aside to use for reassembly.

22. Remove Swivel (3) from spool.

- d. Remove swivel (3) from inside of spool (2) (FIG. 25).

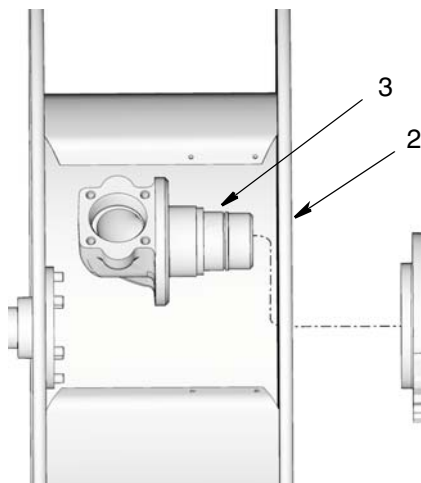

FIG. 25

Low Pressure Spring Swivel Replacement Kit 24R336 and Medium Spring Swivel Replacement Kit 24R337 are available from Graco. See Parts page 39, for additional information about ordering these kits. Reassembly instructions are provided in Step 1, page 18.

23. Remove Shaft (11) from spool.

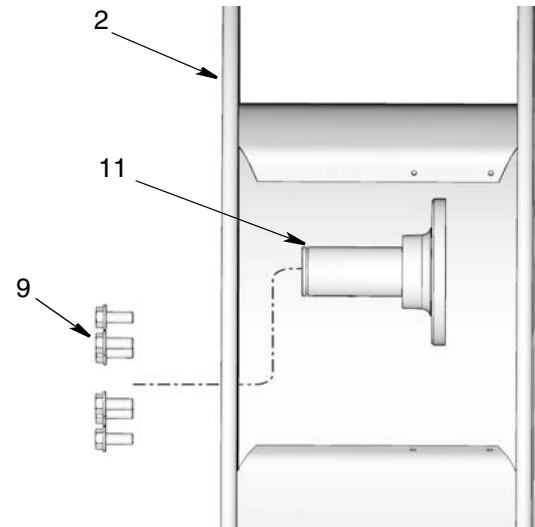

FIG. 26

- e. Remove bolts (9) holding shaft (11) (spring side) to the spool and remove shaft from inside of spool.

C and D Spring Shaft Replacement Kit 24R953 and A and B Spring Shaft Replacement Kit 24R954 are available from Graco. See Parts page 39, for additional information about ordering these kits. Reassembly instructions are provided in Step 3, page 19.

Hose Reel Reassembly

Correctly Installed Swivel (3) and Outlet

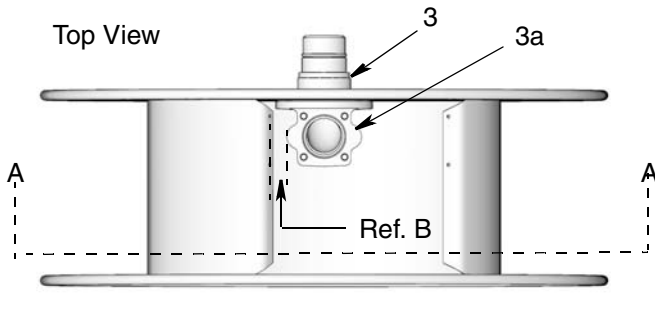

Section View A-A, Showing Outlet Installed Correctly

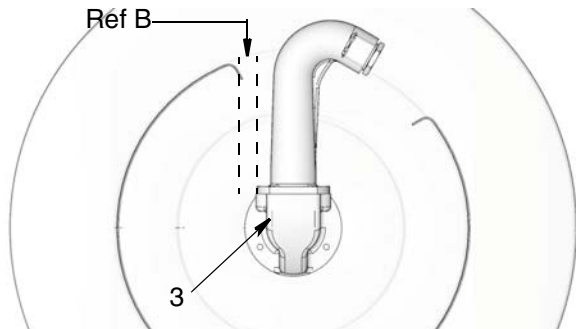
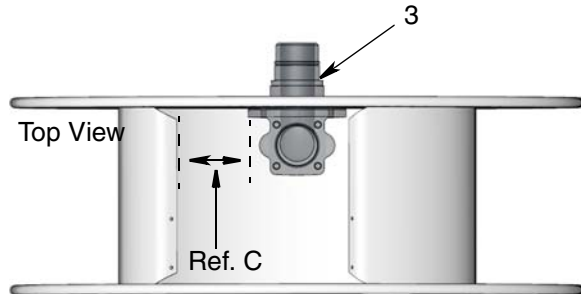

FIG. 27

Incorrectly Installed Swivel (3) On the Wrong Side of the Spool (2)



1. **Install swivel (3) inside spool on the inlet side.**

NOTE: The swivel (3) must be installed on the correct side of the spool (2) and oriented correctly inside the spool to ensure correct hose reel operation.

- a. Slide the swivel through the hole in the center of the spool and rotate the swivel until flat surface (3a) is as parallel as possible to the floor.
- b. Temporarily install one bolt (4) through a hole to hold the swivel in the installed position (FIG. 28).

- c. Rotate the spool (2) until the flat surface (3a) of the swivel is parallel to the floor or table top and matches FIG. 27, Top View, Correctly Installed Swivel and Outlet illustration. This is how your swivel should look inside the spool when it is correctly installed.
- d. Mark the position of the missing threaded screw hole (a) (FIG. 28) on the swivel to use as a reference for lining up the ratchet (31) for installation in Step 2, page 19.

Notice the location of swivel (3) in Ref. B in the Correctly Installed Swivel and Outlet illustration (FIG. 27). This is the correct swivel (3) installation position.

Ref. C shown in the Incorrectly Installed Swivel On the Wrong Side of the Spool illustration (FIG. 27) shows the appearance of the swivel (3) inside the spool when it is incorrectly installed.

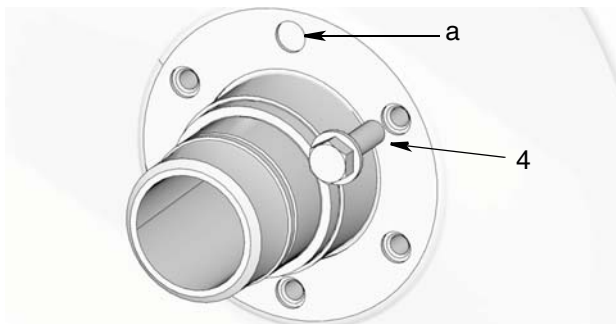

FIG. 28

Refer to these two figures to verify swivel (3) is properly oriented and installed on the correct side of the spool (2).

NOTE: Always compare your swivel installation to the illustrations in FIG. 27 before permanently installing the ratchet (31) and bolts (4). When the swivel (3) is correctly installed in the correct side of the spool, the swivel orientation will EXACTLY match the Top View, Correctly Installed Swivel and Outlet illustration as shown with the swivel facing UP.

If the swivel (3) is incorrectly installed in the spool (3) the reel will not function properly.

2. Install Ratchet.

- a. Slide ratchet (31) over swivel (3) (FIG. 29).

NOTE: When the ratchet is positioned correctly, all 5 bolt holes will be accessible. If you do not have 5 holes available to accommodate all 5 bolts, rotate the ratchet until all 5 holes are open.

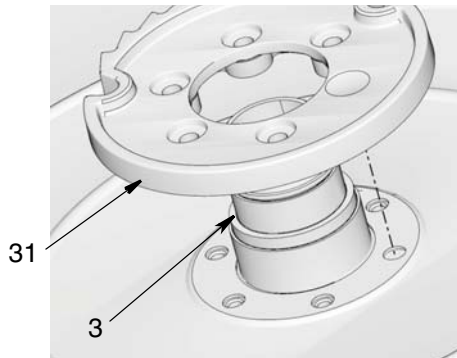

FIG. 29

- b. Install bolts (4) to secure ratchet (31) to spool (FIG. 30). Before tightening bolts, verify swivel (3) is installed in the correct orientation as shown in FIG. 27, page 18. Wrench tighten bolts. Then torque to 25 to 35 ft. lbs (33.9 to 47.45 N.m).

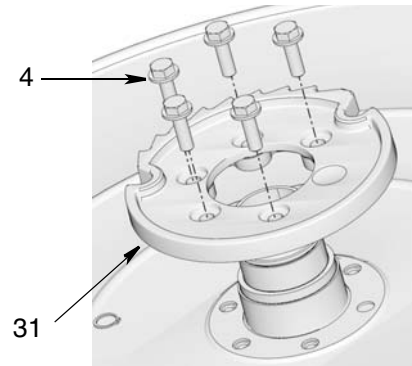

FIG. 30

3. Install shaft (11) inside spool (2) using bolts (9) (FIG. 31). Wrench tighten bolts. Then torque to 25 to 35 ft. lbs (33.9 to 47.45 N.m).

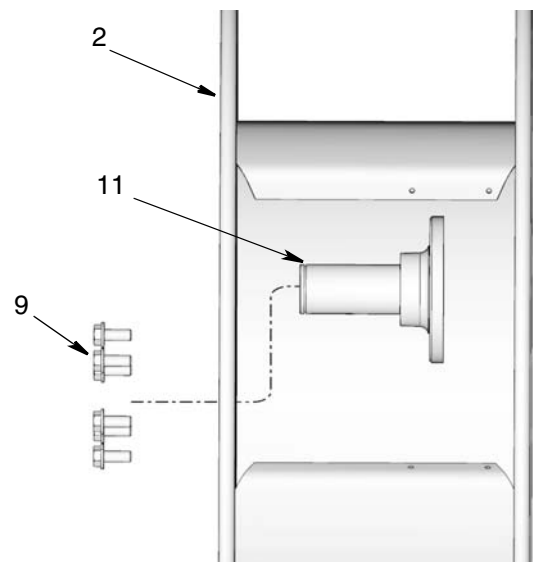

FIG. 31

4. Lay spool on a flat surface or table - inlet side down.

NOTE: Protect surface by wrapping it with black electric tape.

5. Install Bearings.

Medium Pressure Models Bearing Replacement:

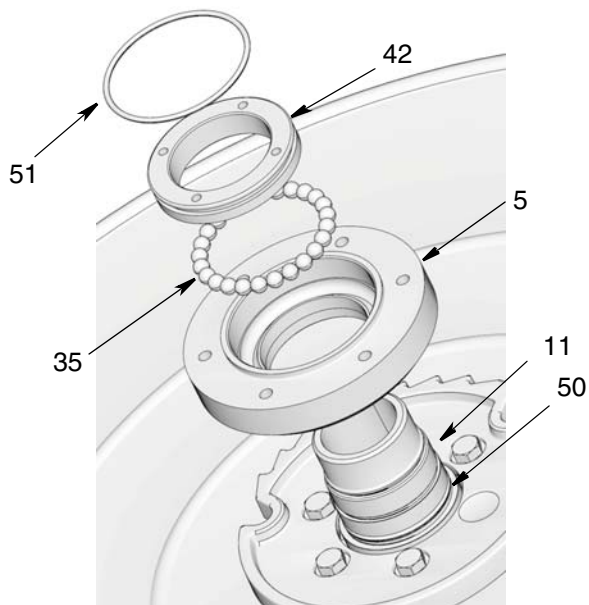

FIG. 32

NOTE: Unless otherwise noted, Steps b - g refer to FIG. 32.

- a. Inspect seals, bearing balls, bearing nut and bearing retainer for nicks and cuts. Replace seals and any parts that are scratched or damaged.
- b. If reusing bearing balls (35) clean bearing balls with a soft, dry cloth.
- c. Grease bearing balls (35).

NOTICE

Use 3 to 3.5 cc of grease only. Over-greasing bearing balls will cause the bearing to prematurely lock up.

- d. Apply a thin layer of grease to seal (51). Install seal around bearing retainer nut (42).
- e. Apply of thin layer of grease to the shaft o-ring (50). Install o-ring around shaft (11).
- f. Apply a thin layer of grease to inside surfaces of bearing retainer (5). Install balls (35) in retainer. Distribute balls evenly and verify there are 24 and they are seated flat.

- g. Install bearing retainer (5) and bearing retainer nut (42). Use a spanner wrench on the bearing nut and tighten it securely. Torque to 20 ft. lbs (27.12 N.m).

Low Pressure Ratchet and Bearing Models:

- a. Slide new bearing retainer assembly (49) onto shaft. Refer to FIG. 33 for the correct orientation of the bearing retainer for assembly.

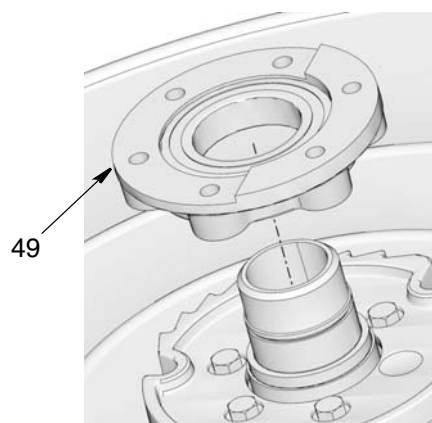

FIG. 33

6. **Install snap ring (41)** over shaft on the inlet side, using a snap ring pliers (FIG. 34). Do not scratch the sealing surface (a).

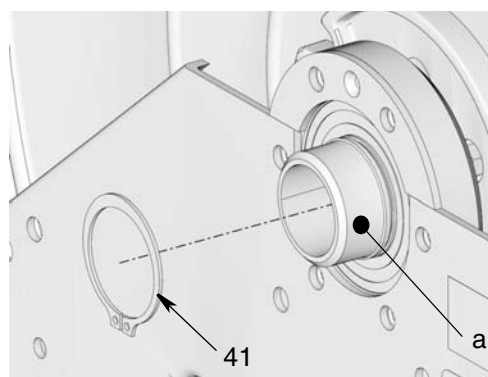

FIG. 34

NOTICE

Be careful not to scratch or score the surface of the (a) when using the snap ring pliers to remove the snap ring (41). Damage to this surface could result in fluid leakage. Protect the surface by wrapping it with black electric tape.

7. Install spool (2) on reel frame (1).

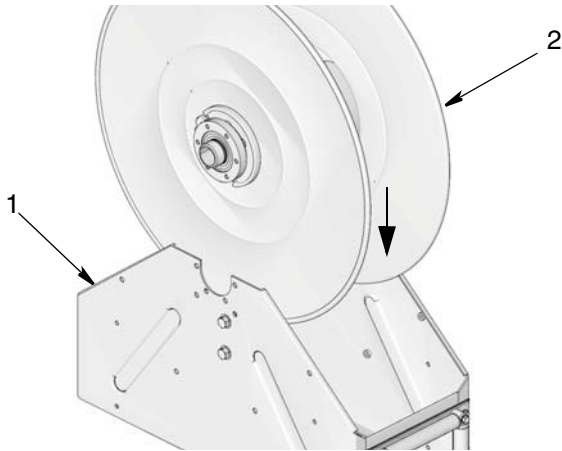

FIG. 35

8. Visually inspect inlet seal and o-ring.

Also, use your finger to feel surface of seal and o-ring for nicks. Replace these parts if damaged.

To replace seals:

- a. Use a pick to remove the damaged white seal (33a) and black o-ring (33b) from the inlet assembly (6) (FIG. 36).

NOTICE

Be careful not to scratch or score the surface of the inlet (6) when using the pick to remove the seal (33a) and o-ring (33b). Damage to this surface could result in fluid leakage.

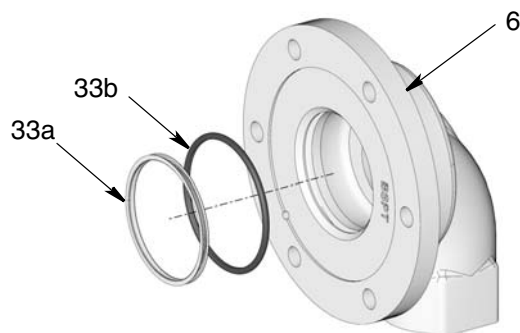

FIG. 36

- b. Apply a thin layer of grease to the black o-ring (33b) and white seal (33a).
- c. Install the new black o-ring (33b) first. Use your fingers to press it into the groove located inside the neck of the inlet assembly (6) (FIG. 37).

NOTE: Folding the o-ring into a U-shape before installation will help seat it correctly inside the inlet assembly. Then use your fingers to press the o-ring into the groove.

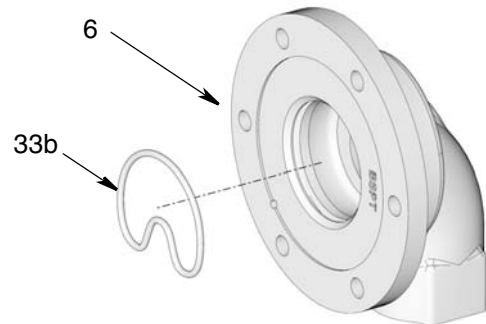

FIG. 37

- d. Install the white seal (33a) over the o-ring (33b) (FIG. 38).

NOTE: Folding the seal into a U-shape before installation will help seat it correctly inside the inlet assembly. Then use your fingers to press the seal into the groove.

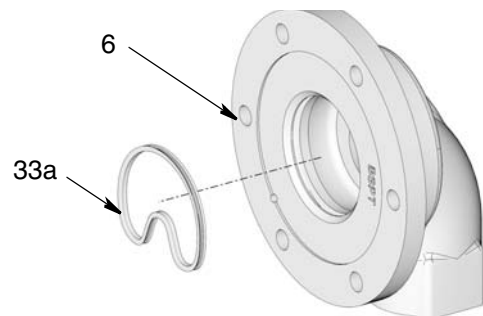

FIG. 38

NOTE: Be careful when installing these parts that they are lying flat inside the groove and do not have any kinks or bends which could result in fluid leakage due to a poorly seated seal.

9. Install inlet on hose reel.

- a. Remove black electric tape if previously installed.
- b. Position inlet (6) in the desired orientation on the base.

Medium Pressure Models ONLY: Align shim (36) between inlet (6) and ratchet (31) (FIG. 39).

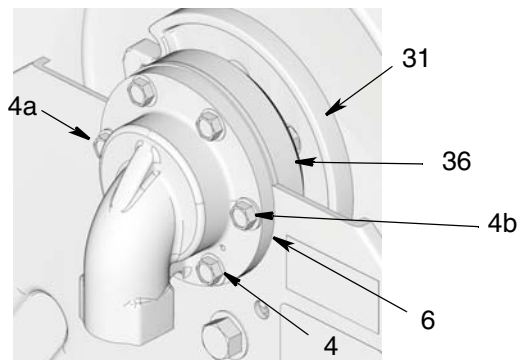

FIG. 39

- c. First install the side 2 bolts (4a and 4b) as shown in FIG. 39 through frame and inlet (6). Tighten bolts just enough to hold everything in place.
- d. Install the remaining bolts (4) (FIG. 39). Hand tighten and then torque all bolts to 13-16 ft. lbs (17.6-20.3 N•m).

10 Install spring side bearing retainer.

- a. On the spring side, install retainer (7) and nuts (38).
- b. Torque nuts to 25 to 35 ft lbs (33.9 to 47.45 N.m) (FIG. 40).

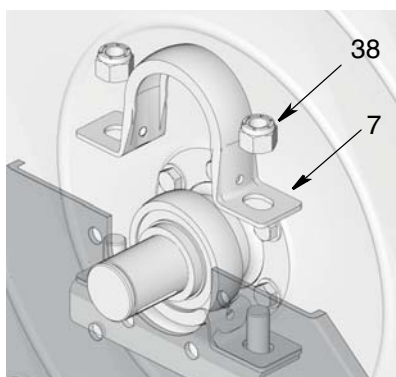

FIG. 40

11. Install power spring.

- a. Separate dust seal (48) from foam disc and remove backing. Adhere the new dust seal (48) to pillow block gear retainer (7).

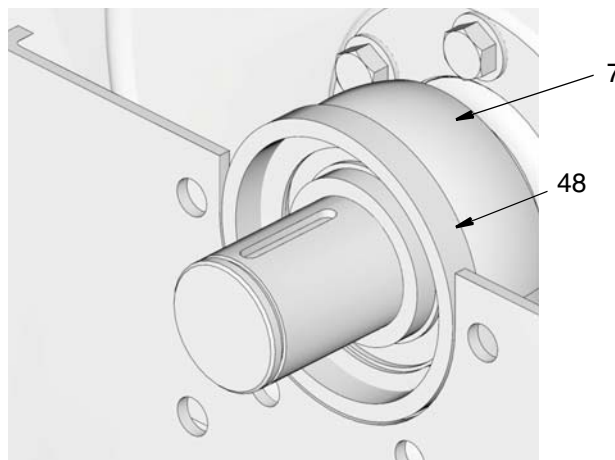

FIG. 41

- b. Rotate shaft (11) so the key-way (b) faces up. Install three spacers (15) over shaft (FIG. 42).

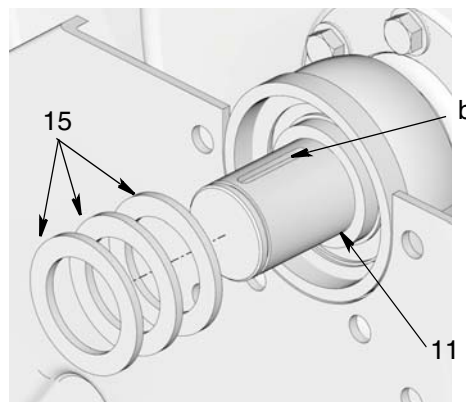

FIG. 42

- c. Install the new spring canister (10) over the shaft.

NOTE: For easier installation, a screwdriver can be used to position the center spring coil over shaft.

- d. First install the outer two bolts (9c and 9d). Then replace the bottom bolts (9a and 9b)(FIG. 43). Torque to 25 to 35 ft. lbs (33.9 to 46.45 N.m).

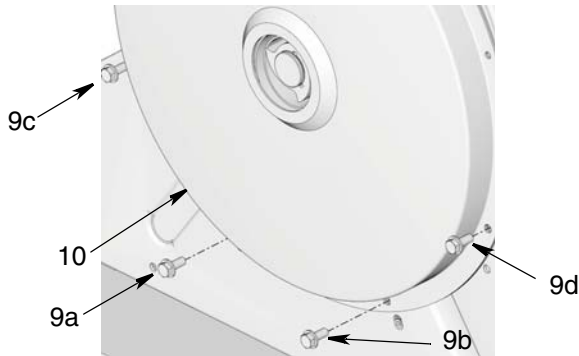

FIG. 43

- e. Install key (12). Align hub (13) in the opening. Push it into place inside the spool. The key should be in the top position.

FIG. 44 shows examples of the hub installed correctly and installed incorrectly.

NOTE: When correctly oriented the hub should easily slide into the opening.

Correct Hub Orientation

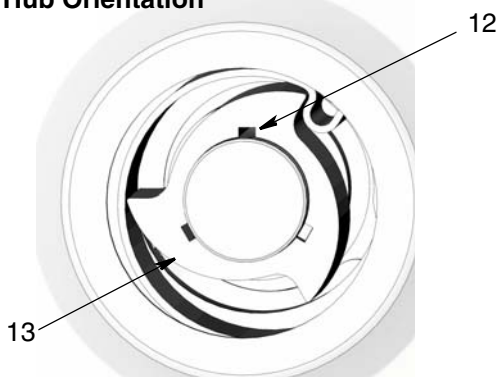

Incorrect Hub Orientation

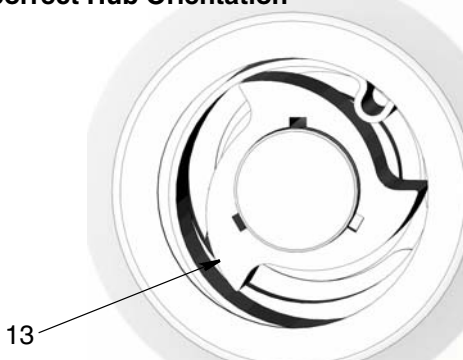

FIG. 44

- f. Install snap ring (14) (FIG. 45).

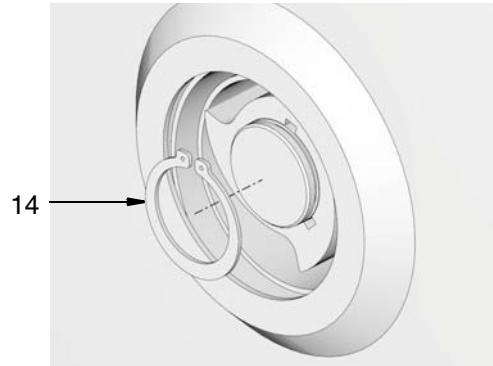

FIG. 45

- g. Install plastic end cap (32).

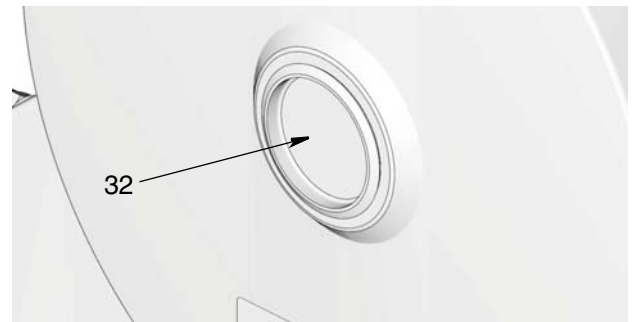

FIG. 46

12. Inspect outlet o-ring.

To replace o-ring:

- a. Use a pick to remove o-ring (34) from outlet (30) (FIG. 47).

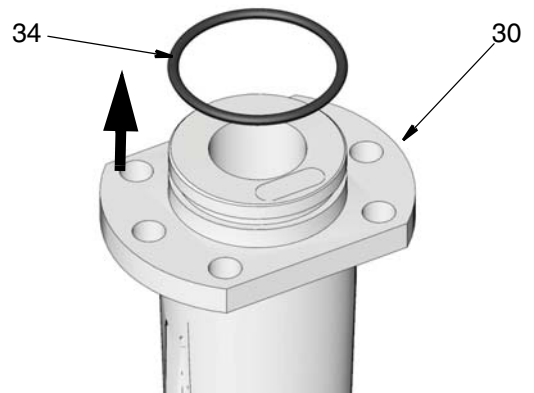

FIG. 47

NOTICE

Be careful not to scratch or score the surface of the outlet (30) when using the pick to remove the o-ring (34). Damage to this surface could result in fluid leakage.

NOTE: If the o-ring (34) is not damaged, you do not need to replace this part. Use a brush to apply a thin layer of grease around the o-ring and threads of the outlet fitting (30). Then continue installation instructions with Step 13

- b. Apply a thin layer of grease to the new o-ring (34) and install new o-ring over outlet (30) as shown in FIG. 48.

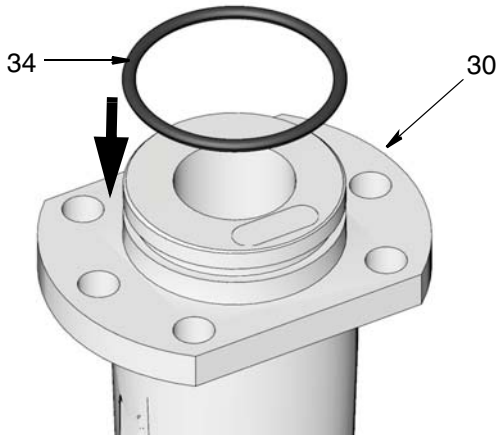

FIG. 48

13. Install outlet to spool.

!						
Always wear heavy, non-slippery gloves when adjusting the spring tension to protect your hands from being cut on the hose reel.						

- a. Pre-wind hose reel as needed to accommodate the length of hose you are installing. Refer to Table 1, Spring Tension and Pre-Turns, page 46 to determine the number of turns needed for your hose and reel model.
- b. Engage the latch. Listen for the loud click when the spool has latched.

NOTE:

- Adhere a piece of tape to the side of the reel flange as a visual reference point for counting reel rotations.
- Wind direction is determined by the direction the spool rotates when the hose is extended during operation.

!					
Never allow the reel to spin freely. Doing so causes the spool to spin out of control, which could cause serious injury if you are hit by the hose or dispense valve.					

- c. Securely attach a c-clamp (A) to the reel spool as shown in FIG. 49 to help prevent the reel from unintentionally becoming unlatched and spinning freely.

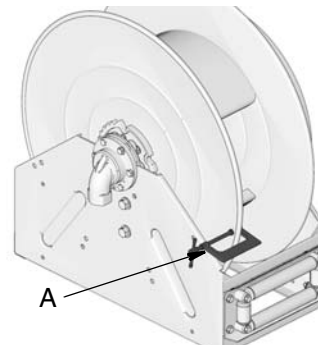

FIG. 49

- d. If hose was removed from outlet (30) during disassembly, or if you are installing a new hose; feed one end of hose through rollers (FIG. 50).

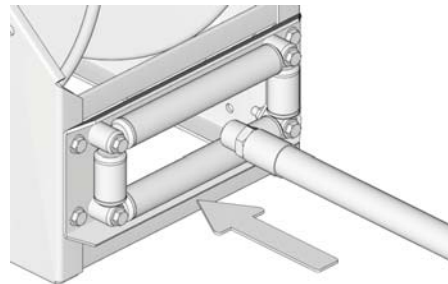

FIG. 50

- e. Securely attach hose to outlet (30).

- f. Reinstall outlet (30) to swivel (3). Replace and tighten all bolts (37) securely. Torque bolts to 24 to 30 ft. pounds (32.54 to 40.67 N.m) (FIG. 51).

NOTE:

- Low Pressure Models (shown in FIG. 51) use 4 bolts (37).
- Medium Pressure Models (not shown) use 6 bolts (37).
- Always use all bolts provided.

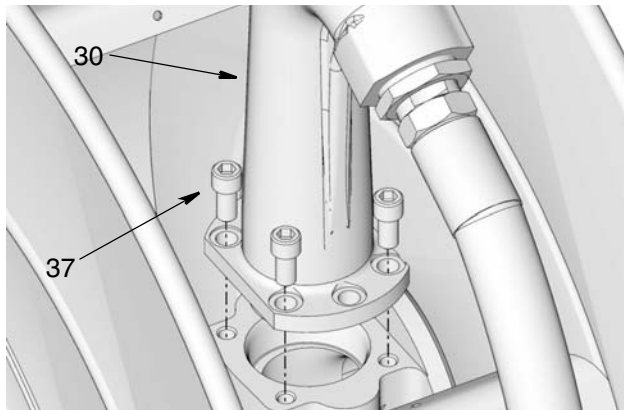

FIG. 51: Low Pressure Model (shown)

14. Install ball stop.

FIG. 52

To install the ball stop:

- Position each half of the stop (45) near the outlet end of the hose (FIG. 52).
- Thread screws (46) through holes in stop pieces (45).
- Tighten nuts (47) until the outside edges of the stop contact each other.

15. Uncoil and extend the hose.

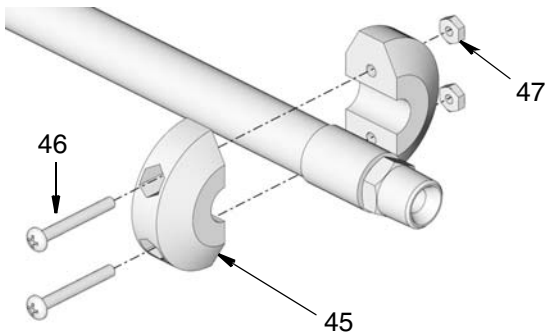
NOTICE

Always hold on to the hose while it is rewinding to avoid damage to the reel.

- Remove c-clamp. Pull the hose firmly enough to release the latch, then slowly allow the hose to retract.
- Remove cap from end of hose and install dispense valve.
- Pressurize hose and verify spring tension.
- If necessary, adjust spring tension. See Spring Tension Adjustment instructions, page 34 and refer to the Table 1: Spring Tension and Pre-turns (page 46) to determine the number of spool rotations needed to correctly set the spring tension for your reel model and hose.

Additional Repair and Replacement Instructions

Removing and Installing New Hose on Reel

Use this procedure to remove the hose from the reel and install a new hose on the bare reel. For this procedure the spring canister is not removed from the spool.

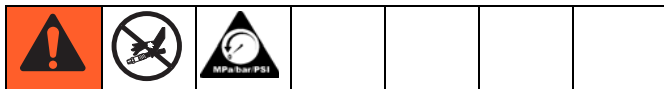

1. Relieve pressure, page 9.
2. Verify there is sufficient access to the back of the hose reel (opposite hose exit) to enable outlet removal. Access is installation dependent. If hose access is not available the hose reel must be taken out of service. See Step 8, Remove Hose Reel From Service, page 11.

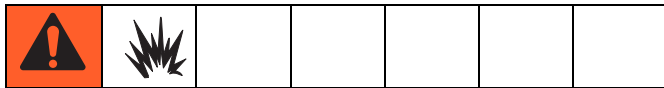

3. Flush fluid from reel and hose.
 - a. Place end of hose in a waste container.



FIG. 53

- b. Blow out entire lubricant supply line with air.

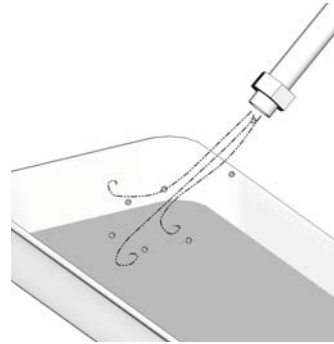

FIG. 54

- c. Cap end of hose to prevent fluid spills.

<ul style="list-style-type: none"> • Always wear heavy, non-slippery gloves when adjusting the spring tension to protect your hands from being cut on the hose reel. • Never allow the reel to spin freely. Doing so causes the spool to spin out of control, which could cause serious injury if you are hit by the hose or dispense valve. 						

4. Pull the hose out far enough to engage the latch. Listen for the loud click when the spool has latched.
5. Remove dispense valve and ball stop.

To remove ball stop: remove nuts (47), screws (46) and ball stop (45) from end of hose (FIG. 55).

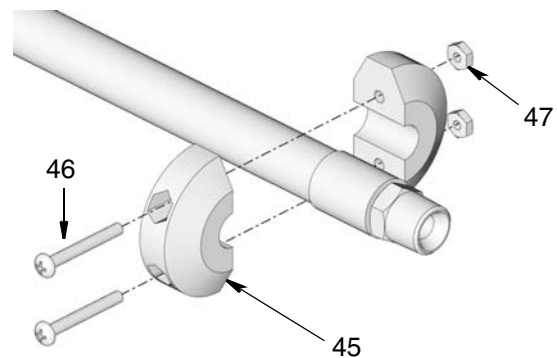

FIG. 55

6. Extend all the hose from spool and engage latch.
7. Securely attach a c-clamp (A) to the reel spool as shown in FIG. 56 to help prevent the reel from unintentionally becoming unlatched and spinning freely.



FIG. 56

8. With hose still attached to outlet, remove bolts (37) and outlet (30) from spool (FIG. 57).

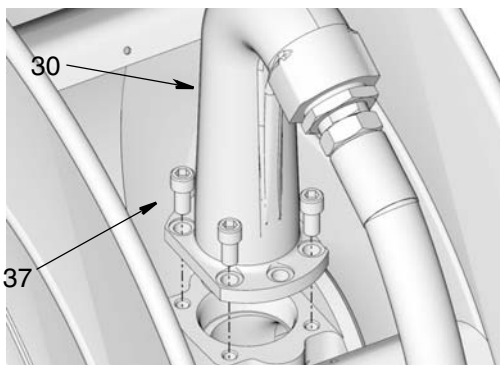

FIG. 57

9. Using two wrenches on the flats, working in opposite directions, loosen and remove the hose from the outlet fitting (FIG. 58).

NOTE: If a reducer (35) was previously installed, it can be reused if required or removed to accommodate a larger hose diameter.

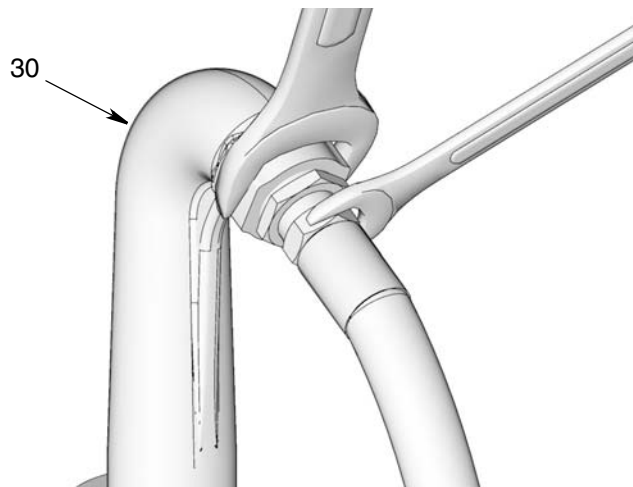

FIG. 58

10. Apply pipe thread sealant or wrap hose threads with PTFE tape.
11. Attach end of the new hose to the outlet (30) using two wrenches on the flats, working in opposite directions, to securely tighten the hose to the outlet fitting (FIG. 59).

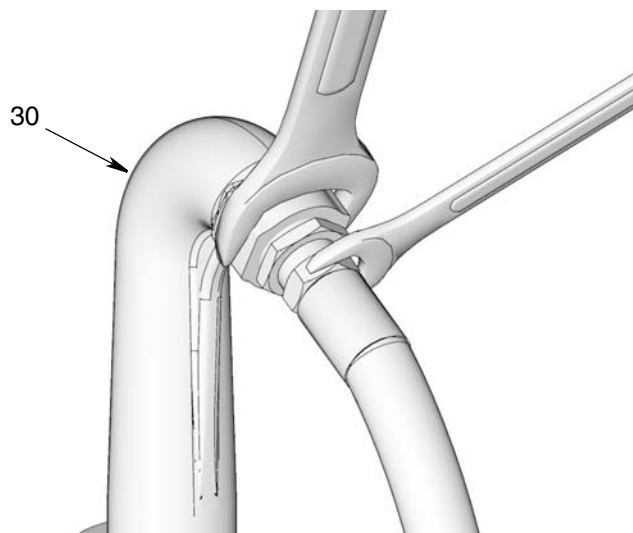

FIG. 59

12. Verify outlet o-ring (34) is in place on outlet (30). Apply a thin layer of grease (G) to o-ring as shown

in FIG. 60.

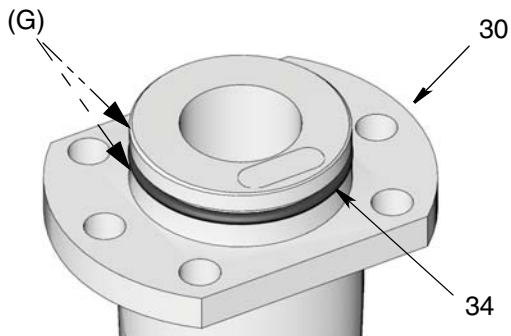

FIG. 60

- d. Install outlet (30) to spool. Replace and tighten all bolts (37) securely. Torque bolts to 24 to 30 ft. pounds (32.54 to 40.67 N.m) (FIG. 61).

NOTE:

- Low Pressure Models (shown in FIG. 51) use 4 bolts (37).
- Medium Pressure Models (not shown) use 6 bolts (37).
- Always use all bolts provided.

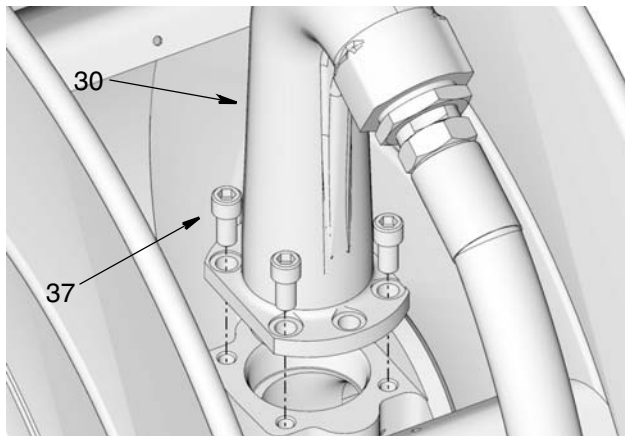





FIG. 61: Low Pressure Model Shown

13. Uncoil and extend hose.
14. Remove c-clamp (A) (installed in Step 7, page 27).
15. Disengage latch by pulling on hose to release it.

Always wear heavy, non-slippery gloves when adjusting the spring tension to protect your hands from being cut on the hose reel.						

16. Use your hand to guide the hose as it rewinds onto the reel.
17. Adjust spring tension if needed. See Adjusting Spring Tension, page 34.
18. Remove cap from end of hose and install dispense valve to end of hose.

First Time Hose Installation

						
<ul style="list-style-type: none"> • Never allow the reel to spin freely. Doing so causes the spool to spin out of control, which could cause serious injury if you are hit by the hose. • Always wear heavy, non-slippery gloves when adjusting the spring tension to protect your hands from being cut on the hose reel. 						

1. Be sure hose reel is secured to a flat surface or installed in its service location. See Disassembly, Step 8b, page 12.
2. Verify the spring is not under tension. If there is spring tension, follow Removing Spring Tension procedure provided on page 36.
3. For easier hose installation, Graco recommends removing the outlet (30) from the spool. To do this remove bolts (37) holding outlet to the spool (FIG. 62).
4. Apply pipe thread sealant or wrap PTFE tape around the threads of reducer (53) (if needed). Then install reducer (53) in the end of the outlet (FIG. 62). Use two wrenches on the flats, working in opposite directions, to securely tighten the reducer to the outlet fitting.

NOTE: A reducer (53) is not required for all installations. It is only necessary if the hose diameter is smaller than the diameter of the outlet (30).

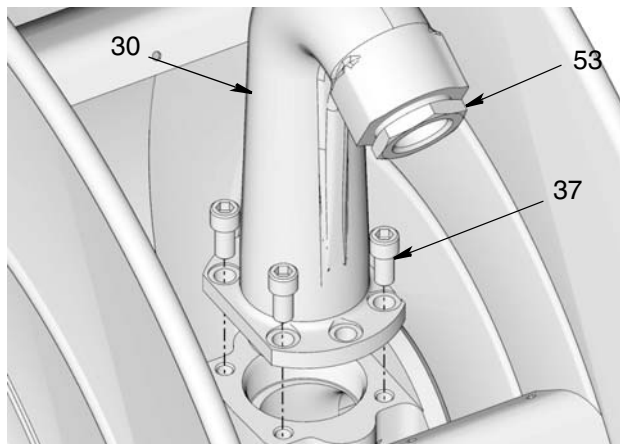

FIG. 62: Low Pressure Outlet shown. Medium Pressure models use 6 bolts.

5. Install ball stop to dispense end of hose.

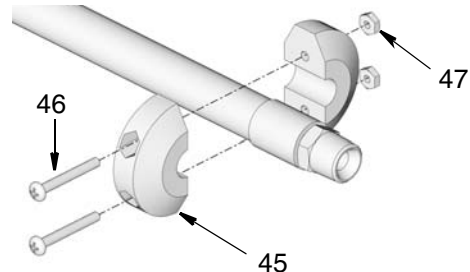

FIG. 63

To install the ball stop:

- a. Position each half of the stop (45) near the outlet end of the hose (FIG. 52).
 - b. Thread screws (46) through holes in stop pieces (45).
 - c. Tighten nuts (47) until the outside edges of the stop contact each other.
6. Uncoil and extend hose.
 7. Feed opposite end of the hose, through the rollers (a), then under the reel (b), and around the back (c) of the spool.

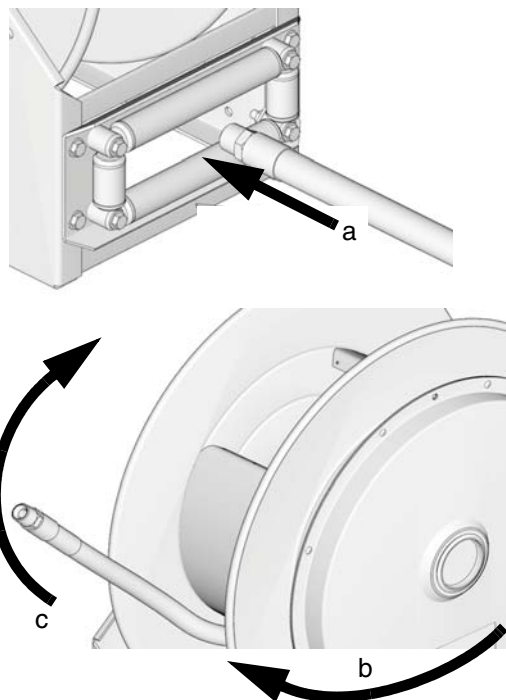

FIG. 64

8. Apply pipe thread sealant or wrap hose threads with PTFE tape.
9. Attach end of the hose to the outlet (30) using two wrenches on the flats, working in opposite directions, to securely tighten the hose to the outlet fitting (FIG. 65).

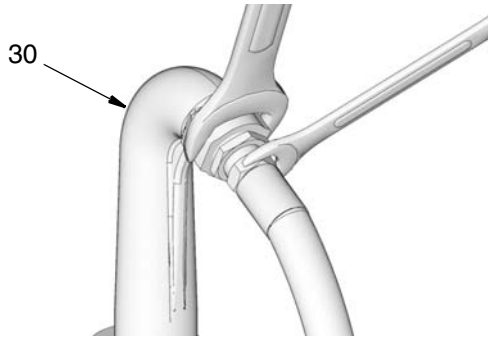

FIG. 65

10. Place a piece of tape on the side of the reel flange as a visual reference point for counting reel rotations.
11. Pre-wind hose reel as needed to accommodate the length of hose you are installing. Refer to Table 1, Spring Tension and Pre-Turns, page 46 to determine the number of turns needed for your hose and reel model.

NOTE: Wind direction is determined by the direction the spool rotates when the hose is extended during operation.

<p>Never allow the reel to spin freely. Doing so causes the spool to spin out of control, which could cause serious injury if you are hit by the hose or dispense valve.</p>					

12. Engage the latch. Listen for the loud click when the spool has latched.

13. Securely attach a c-clamp (A) to the reel spool as shown in FIG. 66 to help prevent the reel from unintentionally becoming unlatched and spinning freely.



FIG. 66

14. Verify outlet o-ring (34) is in place on outlet (30). Apply a thin layer of grease (G) to o-ring as shown in FIG. 67.

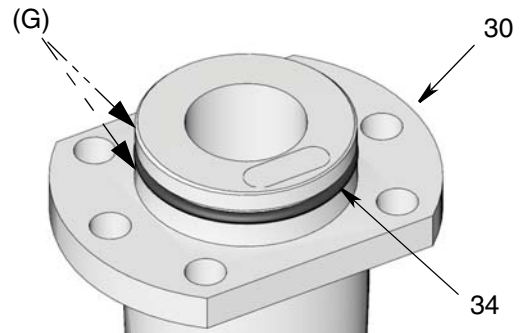

FIG. 67

15. Install outlet (30) to spool. Replace and tighten all bolts (37) securely. Torque bolts to 24 to 30 ft. pounds (32.54 to 40.67 N.m) (FIG. 68).

NOTE:

- Low Pressure Models (shown in FIG. 68) use 4 bolts (37).
- Medium Pressure Models (not shown) use 6 bolts (37).
- Always use all bolts provided.

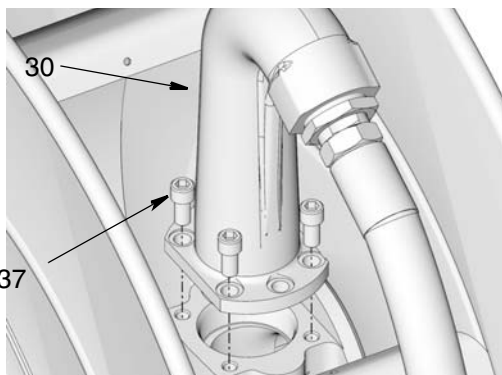

FIG. 68: Low Pressure Model Shown.

16. Remove c-clamp (A) (installed in Step 13, page 30).
17. Disengage latch by pulling on hose to release it.

Always wear heavy, non-slippery gloves when adjusting the spring tension to protect your hands from being cut on the hose reel.						

18. Use your hand to guide the hose as it rewinds onto the reel.
19. Adjust spring tension if needed. See Adjusting Spring Tension, page 34.
20. Remove cap from end of hose and install dispense valve to end of hose.

Roller Guide Replacement

Disassembly

--	--	--	--	--	--	--

1. Relieve pressure, page 9.

Never allow the reel to spin freely. Doing so causes the hose to spin out of control, which could cause serious injury if you are hit by the hose or dispense valve.						

2. Pull the hose out far enough to engage the latch. Listen for the loud click when the spool has latched.
3. Securely attach a c-clamp (A) to the reel spool as shown in FIG. 69 to help prevent the reel from unintentionally becoming unlatched and spinning freely.



FIG. 69

4. Remove dispense valve and ball stop.

To remove ball stop:

Remove nuts (47), screws (46) and ball stop (45) from end of hose (FIG. 70). Cap end of hose (if needed) to prevent fluid spills.

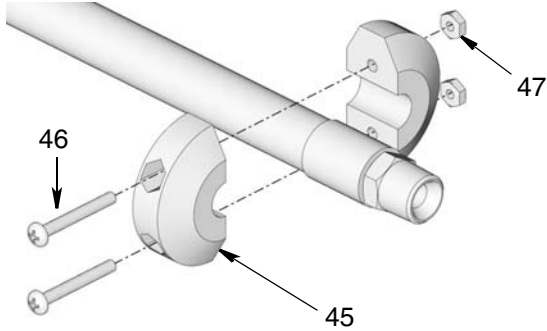

FIG. 70

5. Remove screws (9) and nuts (28) to remove roller plate (43) (FIG. 71).

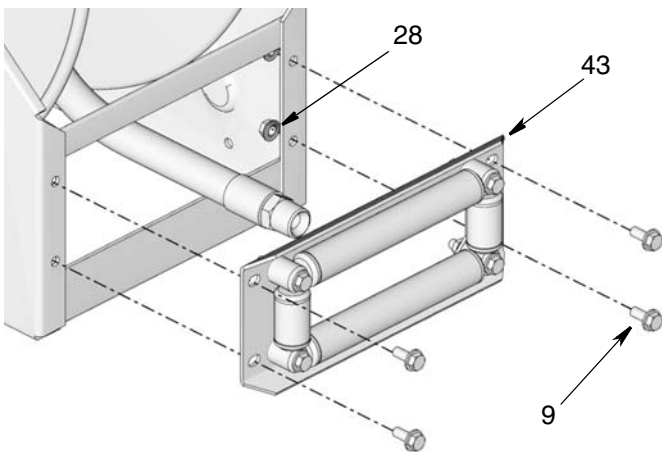

FIG. 71

Roller Guide Reassembly

1. Route end of the hose through the hose rollers (FIG. 72).

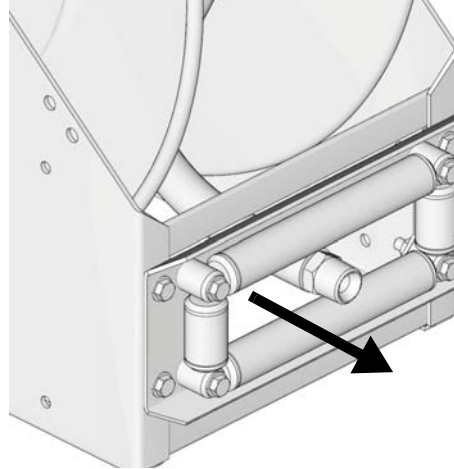

FIG. 72

2. Align plate (43) with front of hose reel base (FIG. 73).

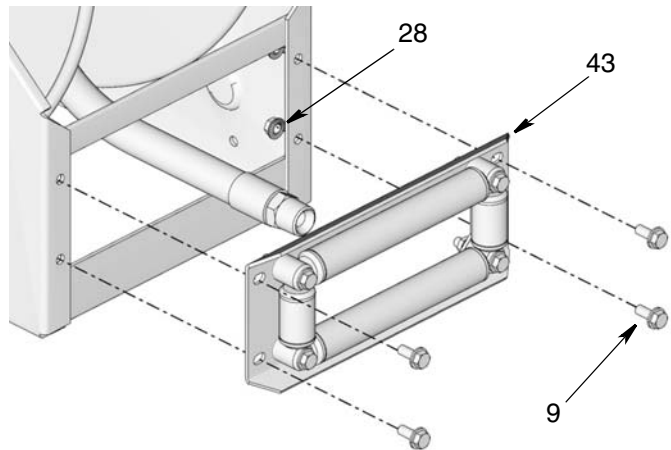

FIG. 73

3. Replace screws (9) and nuts (28) (FIG. 73).
4. Wrench tighten. Then torque to 24-35 ft. lbs (33.9 to 46.45 N.m).

5. Install ball stop and dispensing valve.

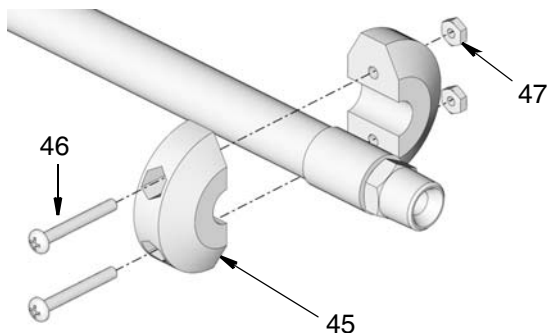

FIG. 74

To install the ball stop:

- a. Position each half of the stop (45) near the outlet end of the hose (FIG. 52).
 - b. Thread screws (46) through holes in stop pieces (45).
 - c. Tighten nuts (47) until the outside edges of the stop contact each other.
 - d. Remove cap from end of hose and install dispense valve to hose end.
6. Remove c-clamp.
 7. Disengage latch.

Latch Replacement

Latch Disassembly

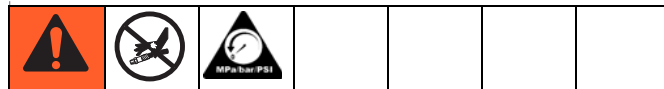

1. Relieve pressure, page 9.



Never allow the reel to spin freely. Doing so causes the spool to spin out of control, which could cause serious injury if you are hit by the hose or dispense valve.

2. Securely attach a c-clamp (A) to the reel spool as shown in FIG. 3 to help prevent the reel from spinning freely (FIG. 75).



FIG. 75

- Remove large bolts (18) holding latch assembly (21) to base (1) (FIG. 76). Discard latch assembly.

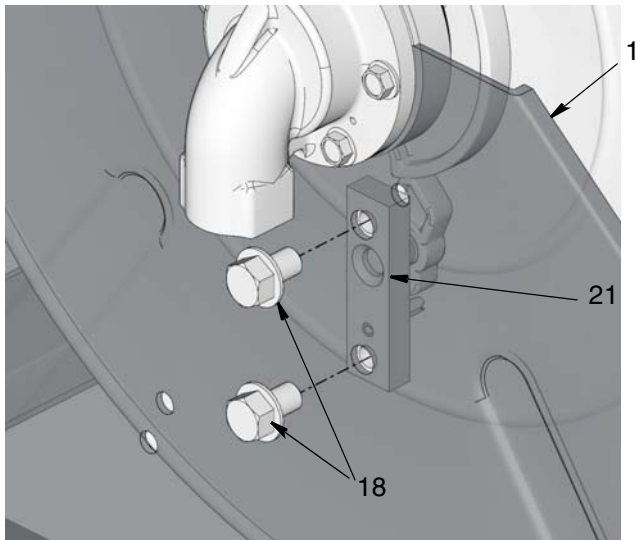

FIG. 76

Latch Reassembly

- Align latch assembly (21) with reel base (1) and orient it as shown in FIG. 76.
- Replace bolts (18).
- Wrench tighten bolts. Then torque to 24-35 ft. lbs (33.9 to 46.45 N.m).
- Remove c-clamp installed in Latch Disassembly, Step 2.

Adjusting Spring Tension

If the hose cannot be pulled all the way out or if it does not retract all the way back onto the hose reel, you need to adjust the spring tension.



- Never allow the reel to spin freely. Doing so causes the spool to spin out of control, which could cause serious injury if you are hit by the hose or dispense valve.
- Always wear heavy, non-slippery gloves when adjusting the spring tension to protect your hands from being cut on the hose reel.

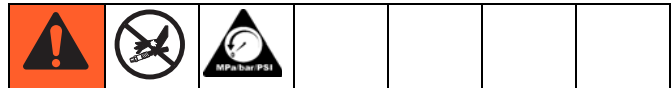

- If the hose reel has been in service, relieve pressure, page 9.
- Pull the hose out far enough to engage the latch.

NOTE: Listen for the loud click when the spool has latched.

- Attach a c-clamp (A) to the reel spool as shown in FIG. 77 to help prevent the reel from unintentionally becoming unlatched and spinning freely.

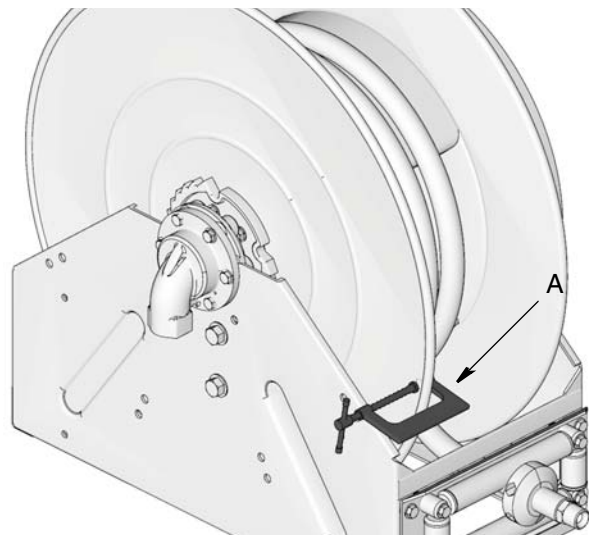

FIG. 77

If a ball stop and dispensing device are **NOT** installed on the hose end, skip Step 4 and continue instructions with Step 5.

- Remove dispense valve, nuts (47), screws (46) and ball stop (45) from end of hose (FIG. 84). Cap end of hose to prevent fluid spills.

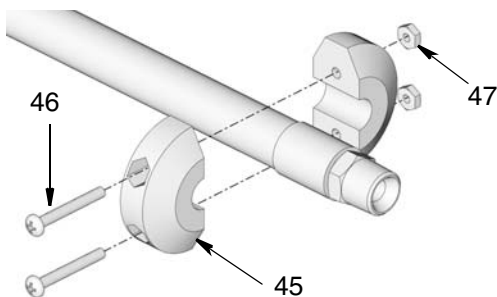

FIG. 78

- Feed the loose end of the hose through the hose rollers and manually wrap and secure the hose onto the reel spool (FIG. 79).

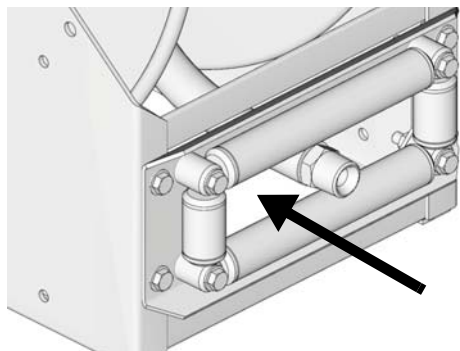

FIG. 79

- Place a piece of tape on the side of the reel flange as a visual reference point for counting reel rotations.
- Remove c-clamp (A) installed in Step 3.
- Rotate reel spool keeping the hose wrapped on the reel.

NOTE:

- Each rotation of the reel spool increases or decreases enough spring tension to retract or let out approximately 5 feet (1.5 m) of hose.
 - Wind spring, in one turn increments, tighter to increase tension.
 - Unwind spring, in one turn increments, to decrease spring tension.

- Refer to the Table 1: Spring Tension and Pre-turns (page 46) to determine the number of spool rotations needed to correctly set the spring tension for your reel model and hose.

- Check the spring tension. When it is set correctly after pulling the hose completely off the spool it will retract fully.

NOTICE

Always hold on to the hose while it is rewinding to avoid damage to the reel.

- Repeat Steps 8 and 9 until you have the proper amount of spring tension.

NOTICE

Do not increase the spring tension so much that the spring winds up tightly before the hose is fully extended. A spring that is wound too tightly:

- Stops the reel from rotating before the hose is fully extended, which puts excessive strain on the hose and reel spring.
- Can cause the latch and ratchet to lock, making disengagement by pulling the hose impossible.

- Rotate spool to engage latch to prevent spool rotation or unwinding.
- Securely attach a c-clamp (A) to the reel spool as shown in FIG. 80 to help prevent the reel from unintentionally becoming unlatched and spinning freely.



FIG. 80

13. Route end of the hose through the hose rollers (FIG. 81).

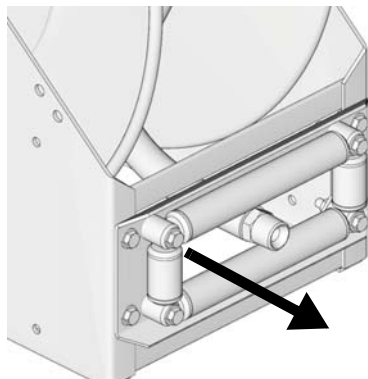

FIG. 81

14. Install ball stop and dispensing valve (FIG. 82).

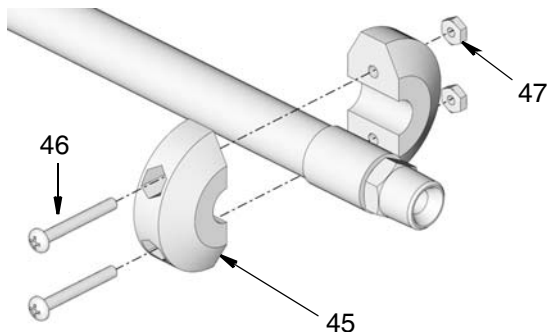
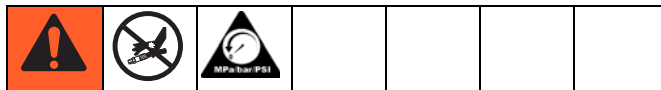

FIG. 82

To install the ball stop:

- a. Position each half of the stop (45) near the outlet end of the hose (FIG. 52).
 - b. Thread screws (46) through holes in stop pieces (45).
 - c. Tighten nuts (47) until the outside edges of the stop contact each other.
15. If hose reel was taken out of service, reinstall hose reel. See XD40/XD50 Hose Reels Installation and Operation instructions.
 16. Remove cap from end of hose and install dispense valve to hose end.
 17. Remove c-clamp (A).
 18. Pressurize hose reel and reverify spring tension.

Removing Spring Tension



1. Relieve pressure, page 9.



Always wear heavy, non-slippery gloves when adjusting the spring tension to protect your hands from being cut on the hose reel.

2. Pull the hose out far enough to engage the latch.

NOTE: Listen for the loud click when the spool has latched.

3. Securely attach a c-clamp (A) to the reel spool as shown in FIG. 83 to help prevent the reel from unintentionally becoming unlatched and spinning freely.



FIG. 83

4. Remove dispense valve, nuts (47), screws (46) and ball stop (45) from end of hose (FIG. 84). Cap end of hose (if needed) to prevent fluid spills.

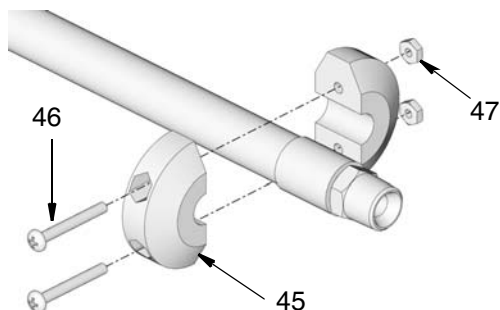

FIG. 84

5. Feed loose end of hose through the hose rollers and manually wrap and secure hose onto reel spool (FIG. 85).

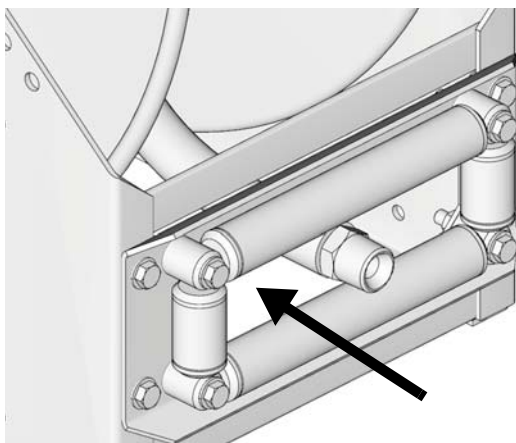

FIG. 85

6. Place a piece of tape on the side of the reel flange as a visual reference point for counting reel rotations.
7. Remove c-clamp (A).
8. Rotate spool in the tightening direction to disengage latch.
9. Use your hands to unwind reel by rotating the spool in the opposite direction turned in step 8, until it the reel reaches a free state. Always keep at least one hand on the spool to prevent free-spool rotation.

NOTE: Count the number of turns while unwinding the spool and record the number for use when tensioning the spring later.

Troubleshooting



Problem	Cause	Solution	
Poor Retraction	Power spring not correctly adjusted	Increase spring pre-load. See Adding Spring Tension, page 34.	
	Hose too stiff	Use correct hose for application. See Parts, beginning on page 39 for the correct hose for you application.	
	Excessive swivel friction and hose bending torque	Reduce operating pressure.	
	Excessive hanging weight of hose and dispense valve	Reduce installation height to recommended values. Do not exceed installation height of 15 ft. (4.57 m). See Parts, beginning on page 39 for the correct hose for you application.	
	Incorrect hose reel / spring for the application		Use recommended reel/spring combination for application.
			Do not use low pressure (LP) reels for Medium Pressure oil dispense.
	Inlet bearing failure	Rebuild or replace inlet bearing, See page 20.	
Spring bearing failure	Rebuild or replace spring bearing.		
Excessive Hose Extension Forces	Power spring not correctly adjusted	Decrease spring pre-load. See Adjusting Spring Tension, page 34.	
	Excessive swivel friction	Reduce operating pressure.	
	Design constraints exceeded for spring reel	Select a power reel for the application.	
Fluid leakage from inlet housing	Worn inlet seal	Replace inlet seal. See Inlet / Inlet Seal and O-Ring Replacement page 20.	
Reel doesn't latch.	Latch pawl broken	Replace latch. See Latch Replacement page 32.	
Reel doesn't retract hose all the way	Power spring broken.	Replace spring canister. See Power Spring Replacement, page 20.	
	Spring hub key broken.	Replace key.	
Fluid leakage from outlet seal	Seal failed	Replace outlet seal. See Outlet / Outlet Seal Replacement page 22.	

XD40/XD50 Parts List

Ref	Part No.	Description	Qty
1		BASE, reel	1
2		SPOOL, hose reel, XD40 models	1
3	16P906^	SWIVEL, Low Pressure models	1
	16P907\$	SWIVEL, Medium Pressure models	1
4\$&@	112586	SCREW, cap, hex head, Low Pressure models	11
		SCREW, cap, hex head, Medium Pressure models	5
5@	16P901	RETAINER, bearing, Medium Pressure models	1
6✓		SWIVEL, inlet	1
7□		RETAINER, bearing, pillow block	1
8□	112953	BEARING, ball	1
9★¥¿	110963	SCREW, cap, flange head	14
10†		SPRING, enclosed	1
11	126150¥	SHAFT, XD40, low pressure, C and D springs	1
	126151¿	SHAFT, XD 40, Medium Pressure and ALL XD50 low and medium pressure , A and B springs	1
12†□¥¿	113267	KEY, square	1
13†		HUB, reel, XD40, low pressure, C and D springs	1
		HUB, reel, XD 40, Medium Pressure and ALL XD50 low and medium pressure , A and B springs	1
14†□¥¿	106082	RING, retaining	1
15□		SPACER, spring, hub	3
16❖	24R066	KIT, latch	1
18❖		SCREW, latch	2
23❖★§	126757	POST, corner	4
24★§	190376	CAP, roller	8
25★§	190378	TUBE, roller, XD40, 1 inch hose and smaller	2
	16P123	TUBE, roller, XD50, 1-1/4 and 1-1/2 inch hoses	2
26★§	190377	TUBE, roller	2
27★§	112960	SCREW, cap, flange head	4
28★	110996	NUT, hex, flange head	8

Ref	Part No.	Description	Qty
29	126596	SCREW, cap, hex head, Low Pressure models	6
30‡✕		SWIVEL, outlet	1
31&	16P903	RATCHET	1
32†□¥\$	112961	CAP, end	1
33✓	126787	SEAL, XD inlet	1
34‡✕	105318	PACKING, o-ring	1
35@		BALL, chrome, 0.375, grade 10, Medium Pressure models	24
36		SHIM, frame, Medium Pressure models	1
37‡✕	108751	SCREW, cap, low pressure	4
	108751	SCREW, cap, medium pressure	6
38□		NUT, nylock, st, 1/2 - 13, zinc	2
39★§	167030	PIN, roller, XD40 models, 1 inch hose and smaller	2
	16P124	PIN, roller, XD50 models, 1-1/4 and 1-1/2 inch hoses	2
40★§	190363	PIN, roller	2
41*@	126643	RING, retaining, 1.969 shaft	1
42@		INSERT, bearing, medium pressure	1
43★	16T624	PLATE, roller, XD40 models, 1 inch hose and smaller	1
	16P081	PLATE, roller, XD50 models, 1-1/4 and 1-1/2 inch hoses	1
44	126359	HOSE, coupled, 1/2 inch x 100 ft, air/water, npt, XD40 models, XD4010DLP	1
	126360	HOSE, coupled, 3/4 inch x 75 ft, air/water, npt, XD40 models, XD4010DLP	1
	126361	HOSE, coupled, 3/4 inch x 100 ft, air/water, npt, XD40 models, XD4010CLP	1
	126362	HOSE, coupled, 1 inch x 50 ft, air/water, npt, XD40 models, XD4010DLP	1
	126375	HOSE, coupled, 1/2 inch x 100 ft, oil, npt, XD40 models, XD4010AMP	1
	126376	HOSE, coupled, 3/4 inch x 75 ft, oil, npt, XD40 models, XD4010BMP	1

Ref	Part No.	Description	Qty
44 (cont)	126377	HOSE, coupled, 3/4 inch x 100 ft, oil, npt, XD40 models, XD4010AMP	1
	126503	HOSE, coupled, 1 inch x 50 ft, oil, npt, XD40 models, XD4010BMP	1
	126379	HOSE, coupled, 1 inch x 50 ft, waste oil evacuation, npt, XD40 models, XD4010CLP	1
	24R102	HOSE, coupled, 1 inch x 50 ft, fuel, npt, XD40 models, XD4010-CLP	1
	126363	HOSE, coupled, 1 inch x 75 ft, air/water, npt, XD50 models, XD5010ALP	1
	126364	HOSE, coupled, 1 inch x 100 ft, air/water, npt, XD50 models, XD5010ALP	1
	126504	HOSE, coupled, 1 inch x 75 ft, oil, npt, XD50 models, XD5010AMP	1
	126380	HOSE, coupled, 1.25 inch x 35 ft, waste oil evacuation, npt, XD50 models, XD5015BLP	1
	126688	HOSE, coupled, 1.25 inch x 50 ft, waste oil evacuation, npt, XD50 models, XD5015BLP	1
	24R103	HOSE, coupled, 1 inch x 75 ft, fuel, npt, XD50 models, XD5010BLP	1
	24R106	HOSE, coupled, 1 inch x 100 ft, fuel, npt, XD50 models, XD5010ALP	1
	24R108	HOSE, coupled, 1.25 inch x 35 ft, fuel, npt, XD50 models, XD5015BLP	1
	24R110	HOSE, coupled, 1.25 inch x 50 ft, fuel, npt, XD50 models, XD5015BLP	1
	24R114	HOSE, coupled, 1.25 inch x 50 ft, fuel, npt, XD50 models, XD5015ALP	1
45◆		STOP, hose	2
46◆	117588	SCREW, machine, phil, pan head	2
47◆	101324	NUT, hex, jam	2
48†□^\$ ¥¿	126467	SEAL, dust	1
49*	24R514	RETAINER, bearing	1
50@	16W910	O-RING, buna	1
51@	126731	O-RING, buna	1

Ref	Part No.	Description	Qty
52*	100380	FITTING, bushing, reducer /2 inch x 1 inch npt	1
	502851	FITTING, bushing, reducer, 3/4 inch x 1 inch npt	1
	121446	FITTING, bushing, reducer, 1-1/4 inch x 1-1/2 inch npt	1
55		LABEL, identification	1
56	16T815	LABEL, XD40	1
57▲	15W036	LABEL, warning	1

▲ Replacement Danger and Warning labels, tags and cards are available at no cost.

See the Related Kits Table provided on page 42, to identify the correct kit to use for your hose reel model.

‡ Parts are included in Outlet Kit 24R056, 24R057, 24R059, 24R665, 24R666, 24R667, 24R668, 24R670, 24R673.

*Parts are included in Outlet Kit 24R053, 24R055, 24R058.

◆Parts are included in Ballstop Kit 222225, 218341, 237872, 24R060, 24R061.

† Parts are included in Power Spring Kit 24R062, 24R063, 24R064, 24R065.

❖Parts are included in Latch Kit 24R066.

✓ Parts are included in Inlet Kit 24R067, 24R068, 24R674, 24R675, 24R677, 24R678.

* Parts are included in Low Pressure Bearing Kit 24R070.

@ Parts are included in Medium Pressure Bearing Kit 24R071.

★Parts are included in Roller Guide Kit 24R072, 24R074.

§ Parts are included in Roller Guide Kit 24R073, 24R075.

□ Parts are included in Spring Side Bearing Kit 24R339.

^ Parts are included in Low Pressure Swivel Kit 24R336.

\$ Parts are included in Medium Pressure Swivel Kit 24R337.

& Parts are included in Ratchet Kit 24R338.

¥ Parts are included in C and D Spring Shaft Replacement Kit 24R953.

¿ Parts are included in A and B Spring Shaft Replacement Kit 24R954.

Related Kits

Part No.	Description
24R053	KIT, outlet, 1/2 inch, npt, XD40, includes parts 30, 34, 37, 52
24R055	KIT, outlet, 3/4 inch, npt, XD40, includes parts 30, 34, 37, 52
24R056	KIT, outlet, 1 inch, npt, XD40, includes parts 30, 34, 37
24R057	KIT, outlet, 1 inch, npt, XD50, includes parts 30, 34, 37
24R058	KIT, outlet, 1-1/4 inch, npt, XD50, includes parts 30, 34, 37, 52
24R059	KIT, outlet, 1-1/2 inch, npt, XD50, includes parts 34, 30, 37
24R665	KIT, outlet, 1 inch, BSPP, XD40, includes parts 30, 34, 37
24R666	KIT, outlet, 1 inch, BSPT, XD40, includes parts 30, 34, 37
24R667	KIT, outlet, 1 inch, BSPP, XD50, includes parts 30, 34, 37
24R668	KIT, outlet, 1 inch, BSPT, XD50, includes parts 30, 34, 37
24R670	KIT, outlet, 1.5 inch, BSPP, XD50, includes parts 30, 34, 37
24R673	KIT, outlet, 1.5 inch, BSPT, XD50, includes parts 30, 34, 37
222225	KIT, ballstop, 1/2 inch, includes parts 45, 46, 47
218341	KIT, ballstop, 3/4 inch, includes parts 45, 46, 47
237872	KIT, ballstop, 1 inch, includes parts 45, 46, 47
24R060	KIT, ballstop, 1-1/4 inch, includes parts 45, 46, 47
24R061	KIT, ballstop, 1-1/2 inch, includes parts 45, 46, 47
24R062	KIT, power spring, D, includes 10, 12, 13, 14, 32, 48
24R063	KIT, power spring, C, includes 10, 12, 13, 14, 32, 48
24R064	KIT, power spring, B, includes 10, 12, 13, 14, 32, 48
24R065	KIT, power spring, A, includes 10, 12, 13, 14, 32, 48
24R066	KIT, latch, includes 17, 18, 19, 20, 21, 22, 23
24R067	KIT, inlet, 1 inch, npt, includes 6, 29, 33
24R068	KIT, inlet, 1-1/2 inch, npt, includes 6, 29, 33
24R674	KIT, inlet, 1 inch, BSPP, includes 6, 29, 33
24R675	KIT, inlet, 1 inch, BSPT, includes 6, 29, 33
24R677	KIT, inlet, 1-1/2 inch, BSPP, includes 6, 29, 33
24R678	KIT, inlet, 1-1/2 inch, BSPT, includes 6, 29, 33

Part No.	Description
24R070	KIT, bearing, low pressure bearing, includes 29, 41, 49
24R071	KIT, bearing, medium pressure, includes 4, 5, 35, 41, 42, 50, 51
24R072	KIT, roller guide, XD40, includes 9, 23, 24, 25, 26, 27, 28, 39, 40, 43
24R073	KIT, roller guide, XD40, includes 23, 24, 25, 26, 27, 39, 40
24R074	KIT, roller guide, XD50, includes 9, 23, 24, 25, 26, 27, 28, 39, 40, 43
24R075	KIT, roller guide, XD50, includes 23, 24, 25, 26, 27, 39, 40
24R076	KIT, support arm, XD40
24R077	KIT, support arm, XD50
24R336	KIT, Low Pressure Shaft, includes parts 3, 4, 32, 48
24R337	KIT, Medium Pressures shaft, includes parts 3, 4, 32, 48
24R339	KIT, bearing, spring side, includes 7, 8, 12, 14, 15, 32, 48
24R111	KIT, inlet hose, 1 inch, air/water and oil, includes 1 inch swivel fitting and 1 inch x 28 inch coupled hose
24R112	KIT, inlet hose, 1 inch, waste oil evacuation, includes 1 inch swivel fitting and 1 inch x 28 inch coupled hose
24R115	KIT, inlet hose, 1 inch, fuel, includes 1 inch swivel fitting and 1 inch x 28 inch coupled hose
24R117	KIT, inlet hose, 1.5 inch, fuel, includes 1 inch swivel fitting and 1.5 inch x 28 inch coupled hose
24R953	KIT, shaft, low pressure, includes 9, 11, 12, 14, 32, 48
24R954	KIT, shaft, medium pressure, includes 9, 11, 12, 14, 32, 48
237932	KIT, mounting, overhead, fits standard I-beams with flanges up to 7 in. (178 mm)

Technical Data

XD40, XD50 Hose Reels		
	US	Metric
Maximum fluid working pressure	See model table, page 3-6	
Operating Temperature		
Bare Reels	-40°F to 180°F	-40°C to 82°C
Air / Water Reels	-40°F to 180°F	-40°C to 82°C
Waste Oil Evacuation Reels	-40°F to 180°F	-40°C to 82°C
1/2-inch and 3/4-inch Oil Reels	-40°F to 180°F	-40°C to 82°C
1-inch Oil Reels	-20°F to 180°F	-29°C to 82°C
Diesel Fuel Reels	-40°F to 140°F	-40°C to 60°C
Inlet/Outlet Sizes		
XD4010 / XD5010 Inlet size	1 npt(f)	
XD4010 / XD5010 Outlet size	1 npt(f)	
XD5015 Inlet size	1-1/2 in. npt(f)	
XD5015 Outlet size	1-1/2 npt(f)	
Materials of construction		
XD40 Wetted materials	carbon steel, nickel plated cast iron, buna-n rubber, UHMWPE	
XD50 Wetted materials	carbon steel, nickel plated cast iron, buna-n rubber, UHMWPE	
Noise (dBa)		
Sound Pressure Level†	77.6 dB(a)	
Sound Power Level‡	86.8 dB(a)	
Weight (Bare Reels)		
XD4010 DLP models	116 lb.	52.6 kg
XD4010 CLP models	125 lb.	56.7 kg
XD4010CMP models	125 lb.	56.7 kg
XD4010 BMP models	134 lb.	60.8 kg
XD4010 AMP models	152 lb.	68.9 kg
XD5010 ALP models	162 lb.	73.4 kg
XD5010 BLP models	145 lb.	65.7 kg
XD5010 AMP models	162 lb.	73.4 kg
XD5015 BLP models	146 lb.	66.2 kg
XD5015 ALP models	164 lb.	74.4 kg
Maximum Recommended Mounting Height		
XD40 models	15 feet	4.6 meters
XD50 and XD4010 CMP models	8 feet	2.4 meters
Notes		
† Calculated at a distance of 1 meter from measurements taken per ISO 9614-2 @ an assumed retraction/extension rate of 20 spool revolutions per minute.		
‡ Measured per ISO 9614-2 @ an assumed retraction/extension rate of 20 spool revolutions per minute.		

Dimensions

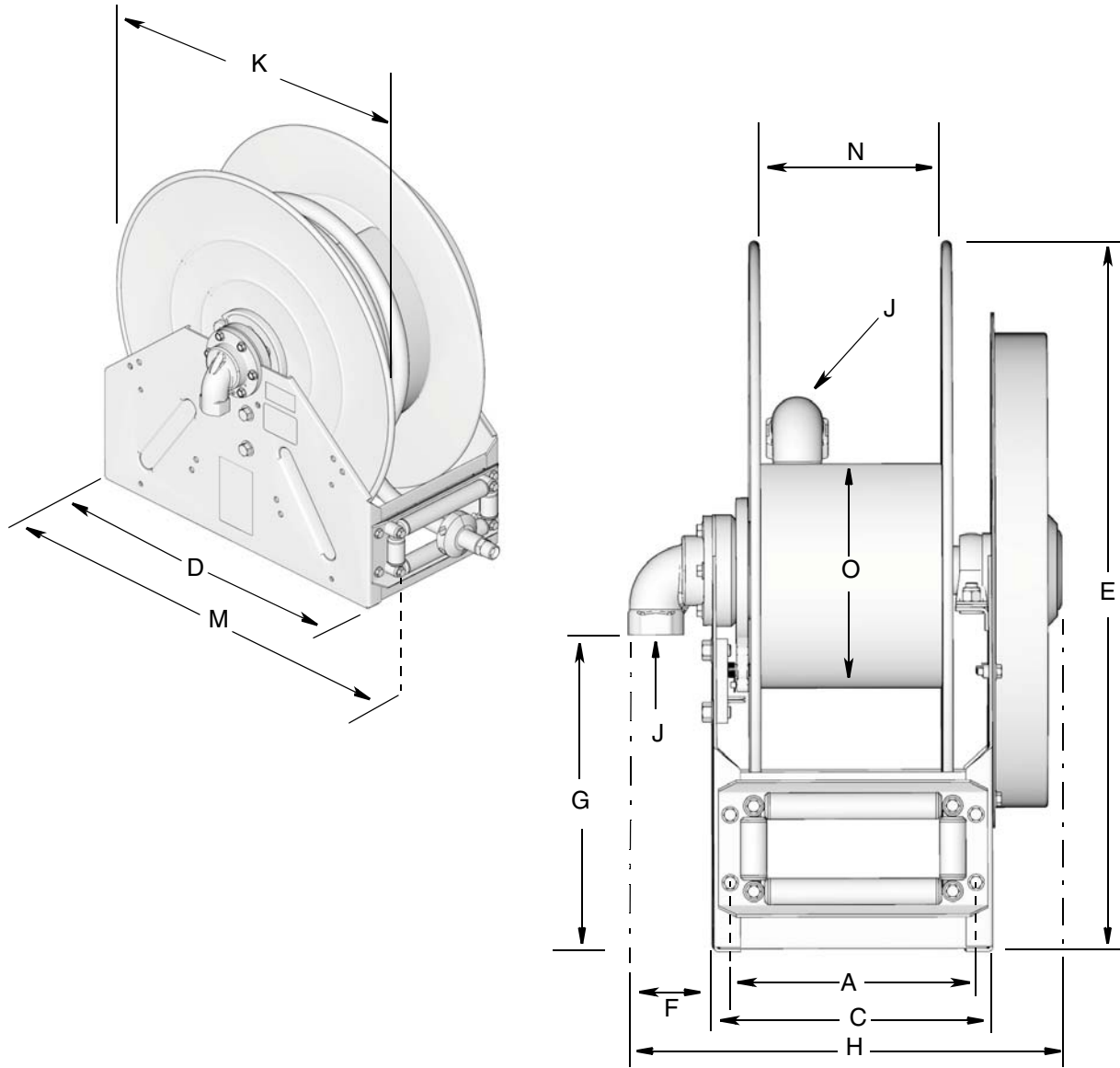

All dimensions shown in inches

Model	Spring	A	C	D	E	F	G	H	J	K	M	N	O
XD4010	C/D	10.45	11.83	24.0	26.13	2.82	10.91	16.54	1.0 npt	25.0	26.4	7.8	15.5
XD4010	A/B			28.5	30.13			17.47					
XD5010	A/B			28.5	30.13			3.59	18.24	1-1/2 npt	28.0		
XD5015	A/B												

All dimensions shown in mm

Model	Spring	A	C	D	E	F	G	H	J	K	M	N	O
XD4010	C/D	265.4	300	610	664	72	277	420	1.0 npt	635	671	198	394
XD4010	A/B			724	765			444					
XD5010	A/B			724	765			91	463	1-1/2 npt	711.2		
XD5015	A/B												

Mounting Hole Pattern

XD40 Reels

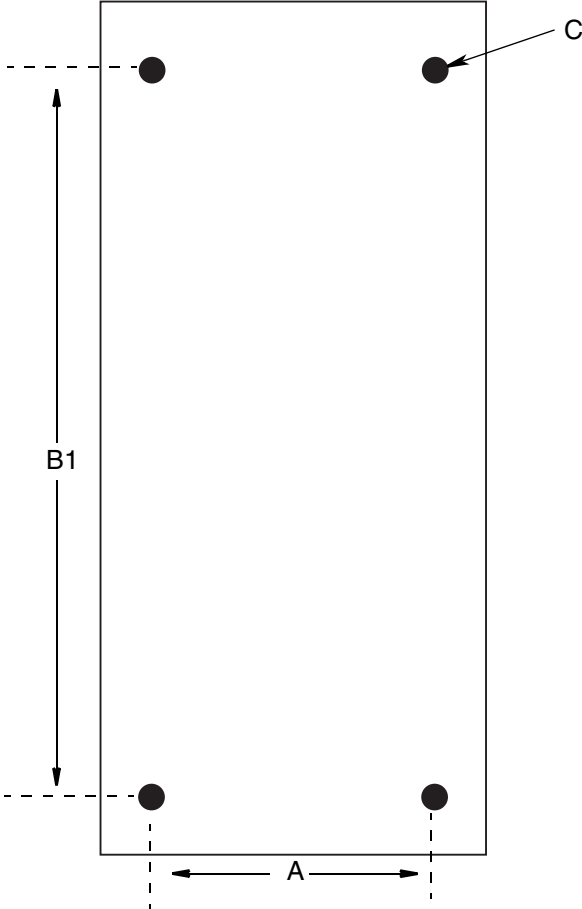

XD50 Reels

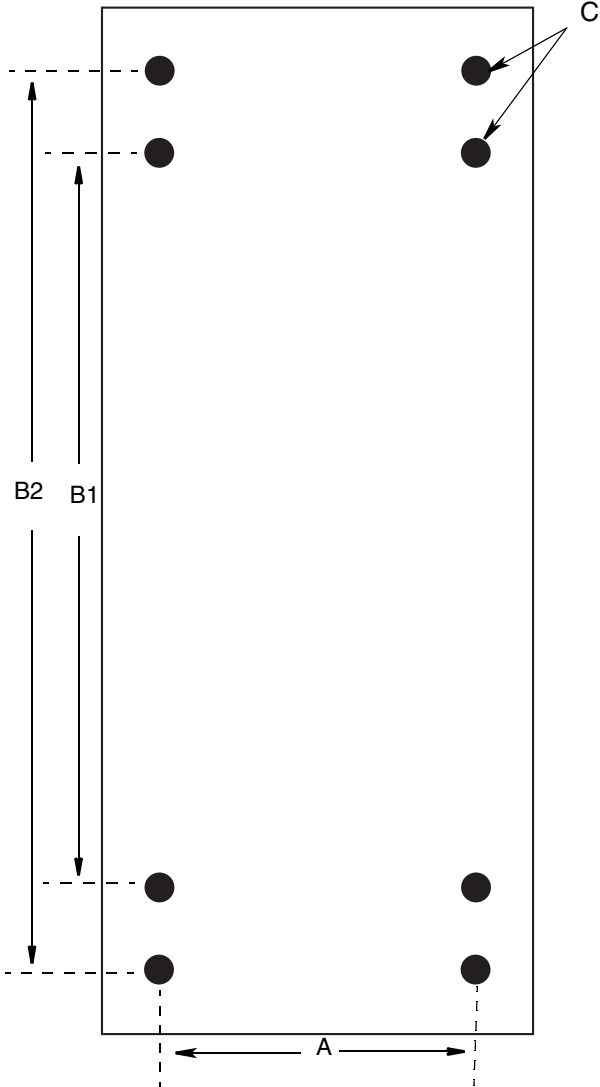

All dimensions shown in inches

Model	Spring	A	B1	B2	C
XD4010	C/D	10.45	22.25	n/a	Ø 0.437
XD4010	A/B				
XD5010	A/B			26.73	
XD5015	A/B				

All dimensions shown in mms

Model	Spring	A	B1	B2	C
XD4010	C/D	265.4	565.2	n/a	Ø 11
XD4010	A/B				
XD5010	A/B			678.9	
XD5015	A/B				

Table 1: Spring Tension Pre-turns

Air / Water Models

Model	Hose Inside Diameter	Hose Length	Number of Pre-Turns From Relaxed State
XD40	0.5 inch	100 feet	24
XD40	0.75 inch	75 feet	25
XD40	0.75 inch	100 feet	25
XD40	1 inch	50 feet	24
XD50	1 inch	75 feet	22
XD50	1 inch	100 feet	26

Oil Models

Model	Hose Inside Diameter	Hose Length	Number of Pre-Turns From Relaxed State
XD40	0.5 inch	100 feet	25
XD4010B	0.75 inch	75 feet	25
XD4010C	0.75 inch	75 feet	27
XD40	0.75 inch	100 feet	30
XD4010B	1 inch	50 feet	25
XD4010C	1 inch	50 feet	27
XD50	1 inch	75 feet	30

Waste Oil Evacuation Models

Model	Hose Inside Diameter	Hose Length	Number of Pre-Turns From Relaxed State
XD40	1 inch	50 feet	26
XD50	1.25 inch	35 feet	17
XD50	1.25 inch	50 feet	20

Fuel Models

Model	Hose Inside Diameter	Hose Length	Number of Pre-Turns From Relaxed State
XD40	1 inch	50 feet	26
XD50	1 inch	75 feet	21
XD50	1 inch	100 feet	26
XD50	1.25 inch	35 feet	18
XD50	1.25 inch	50 feet	21
XD50	1.5 inch	50 feet	22

Graco XD40/XD50 Hose Reel Warranty

Graco warrants all equipment referenced in this document which is manufactured by Graco and bearing its name to be free from defects in material and workmanship on the date of sale to the original purchaser for use. With the exception of any special, extended or limited warranty published by Graco, Graco will, for a period as defined in the table below from the date of sale, repair or replace equipment covered by this warranty and determined by Graco to be defective. This warranty applies only when the equipment is installed, operated and maintained in accordance with Graco's written recommendations.

Component	Warranty Period
Wear parts, including but not limited to: hose, swivel seals, roller guide, bearings, latch	12 months
Hose reel frame: welded base and spool only	84 months

This warranty does not cover, and Graco shall not be liable for general wear and tear, or any malfunction, damage or wear caused by faulty installation, misapplication, abrasion, corrosion, inadequate or improper maintenance, negligence, accident, tampering, or substitution of non-Graco component parts. Nor shall Graco be liable for malfunction, damage or wear caused by the incompatibility of Graco equipment with structures, accessories, equipment or materials not supplied by Graco, or the improper design, manufacture, installation, operation or maintenance of structures, accessories, equipment or materials not supplied by Graco.

This warranty is conditioned upon the prepaid return of the equipment claimed to be defective to an authorized Graco distributor for verification of the claimed defect. If the claimed defect is verified, Graco will repair or replace free of charge any defective parts. The equipment will be returned to the original purchaser transportation prepaid. If inspection of the equipment does not disclose any defect in material or workmanship, repairs will be made at a reasonable charge, which charges may include the costs of parts, labor, and transportation.

THIS WARRANTY IS EXCLUSIVE, AND IS IN LIEU OF ANY OTHER WARRANTIES, EXPRESS OR IMPLIED, INCLUDING BUT NOT LIMITED TO WARRANTY OF MERCHANTABILITY OR WARRANTY OF FITNESS FOR A PARTICULAR PURPOSE.

Graco's sole obligation and buyer's sole remedy for any breach of warranty shall be as set forth above. The buyer agrees that no other remedy (including, but not limited to, incidental or consequential damages for lost profits, lost sales, injury to person or property, or any other incidental or consequential loss) shall be available. Any action for breach of warranty must be brought within 48 months of the date of sale, or 24 months for all other parts.

GRACO MAKES NO WARRANTY, AND DISCLAIMS ALL IMPLIED WARRANTIES OF MERCHANTABILITY AND FITNESS FOR A PARTICULAR PURPOSE, IN CONNECTION WITH ACCESSORIES, EQUIPMENT, MATERIALS OR COMPONENTS SOLD BUT NOT MANUFACTURED BY GRACO. These items sold, but not manufactured by Graco (such as electric motors, switches, hose, etc.), are subject to the warranty, if any, of their manufacturer. Graco will provide purchaser with reasonable assistance in making any claim for breach of these warranties.

In no event will Graco be liable for indirect, incidental, special or consequential damages resulting from Graco supplying equipment hereunder, or the furnishing, performance, or use of any products or other goods sold hereto, whether due to a breach of contract, breach of warranty, the negligence of Graco, or otherwise.

FOR GRACO CANADA CUSTOMERS

The Parties acknowledge that they have required that the present document, as well as all documents, notices and legal proceedings entered into, given or instituted pursuant hereto or relating directly or indirectly hereto, be drawn up in English. Les parties reconnaissent avoir convenu que la rédaction du présente document sera en Anglais, ainsi que tous documents, avis et procédures judiciaires exécutés, donnés ou intentés, à la suite de ou en rapport, directement ou indirectement, avec les procédures concernées.

Graco Information

For the latest information about Graco products, visit www.graco.com.

TO PLACE AN ORDER, contact your Graco distributor or call to identify the nearest distributor.
Phone: 612-623-6928 or **Toll Free:** 1-800-533-9655, **Fax:** 612-378-3590

*All written and visual data contained in this document reflects the latest product information available at the time of publication.
Graco reserves the right to make changes at any time without notice.*

For patent information, see www.graco.com/patents.

Original instructions. This manual contains English. MM 332203

Graco Headquarters: Minneapolis
International Offices: Belgium, China, Japan, Korea

GRACO INC. AND SUBSIDIARIES • P.O. BOX 1441 • MINNEAPOLIS MN 55440-1441 • USA

Copyright 2013, Graco Inc. All Graco manufacturing locations are registered to ISO 9001.

www.graco.com

April 2013; revised October 2013