

Center Drive Box Lubricator

3A2953D

EN

Fluid container used with GBL7500 Gravity Fed or Pressure Fed Box Lubricator Pumps for dispensing non-corrosive and non-abrasive oils and lubricants. For professional use only.

Not approved for use in European explosive atmosphere locations.

See Technical Data, page 11 for maximum outlet pressures per pump station.

Model: 24N724, 24U750

3/16" 7500 psi (51.71 MPa, 517.1 bar) Maximum Working Pressure

1/4" 6000 psi (41.37 MPa, 413.7 bar) Maximum Working Pressure

3/8" 2500 psi (17.24 MPa, 172.4bar) Maximum Working Pressure





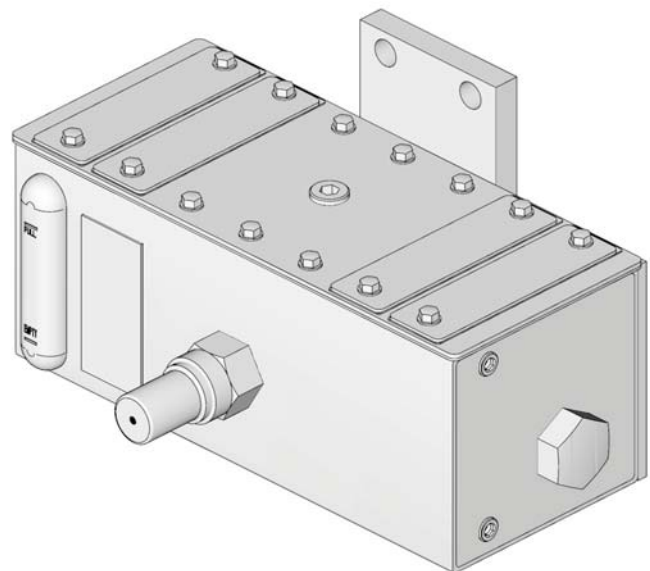

Important Safety Instructions

Read all warnings and instructions in this manual and your pump instruction manual. Save all instructions.



Warnings

The following warnings are for the setup, use, grounding, maintenance, and repair of this equipment. The exclamation point symbol alerts you to a general warning and the hazard symbols refer to procedure-specific risks. When these symbols appear in the body of this manual, refer back to these Warnings. Product-specific hazard symbols and warnings not covered in this section may appear throughout the body of this manual where applicable.

 WARNING	
 	<p>FIRE AND EXPLOSION HAZARD</p> <p>When flammable fluids are present in the work area, such as gasoline and windshield wiper fluid, be aware that flammable fumes can ignite or explode. To help prevent fire and explosion:</p> <ul style="list-style-type: none"> • Use equipment only in well ventilated area. • Eliminate all ignition sources, such as cigarettes and portable electric lamps. • Keep work area free of debris, including rags and spilled or open containers of solvent and gasoline. • Do not plug or unplug power cords or turn lights on or off when flammable fumes are present. • Ground all equipment in the work area. • Use only grounded hoses. • Stop operation immediately if static sparking occurs or you feel a shock. Do not use equipment until you identify and correct the problem. • Keep a working fire extinguisher in the work area.
 	<p>SKIN INJECTION HAZARD</p> <p>High-pressure fluid from dispensing device, hose leaks, or ruptured components will pierce skin. This may look like just a cut, but it is a serious injury that can result in amputation. Get immediate surgical treatment.</p> <ul style="list-style-type: none"> • Do not point dispensing device at anyone or at any part of the body. • Do not put your hand over the fluid outlet. • Do not stop or deflect leaks with your hand, body, glove, or rag. • Follow the Pressure Relief Procedure when you stop dispensing and before cleaning, checking, or servicing equipment. • Tighten all fluid connections before operating the equipment. • Check hoses and couplings daily. Replace worn or damaged parts immediately.



WARNING



EQUIPMENT MISUSE HAZARD

Misuse can cause death or serious injury.

- Do not operate the unit when fatigued or under the influence of drugs or alcohol.
- Do not exceed the maximum working pressure or temperature rating of the lowest rated system component. See **Technical Data** in all equipment manuals.
- Use fluids and solvents that are compatible with equipment wetted parts. See Technical Data in all equipment manuals. Read fluid and solvent manufacturer's warnings. For complete information about your material, request MSDS from distributor or retailer.
- Do not leave the work area while equipment is energized or under pressure.
- Turn off all equipment and follow the **Pressure Relief Procedure** when equipment is not in use.
- Check equipment daily. Repair or replace worn or damaged parts immediately with genuine manufacturer's replacement parts only.
- Do not alter or modify equipment. Alterations or modifications may void agency approvals and create safety hazards.
- Make sure all equipment is rated and approved for the environment in which you are using it.
- Use equipment only for its intended purpose. Call your distributor for information.
- Route hoses and cables away from traffic areas, sharp edges, moving parts, and hot surfaces.
- Do not kink or over bend hoses or use hoses to pull equipment.
- Keep children and animals away from work area.
- Comply with all applicable safety regulations.



MOVING PARTS HAZARD

Moving parts can pinch, cut or amputate fingers and other body parts.



- Keep clear of moving parts.
- Do not operate equipment with protective guards or covers removed.
- Pressurized equipment can start without warning. Before checking, moving, or servicing equipment, follow the **Pressure Relief Procedure** and disconnect all power sources.



PERSONAL PROTECTIVE EQUIPMENT

Wear appropriate protective equipment when in the work area to help prevent serious injury, including eye injury, hearing loss, inhalation of toxic fumes, and burns. This protective equipment includes but is not limited to:

- Protective eye wear, and hearing protection.
- Respirators, protective clothing, and gloves as recommended by the fluid and solvent manufacturer.

Installation

Component Identification

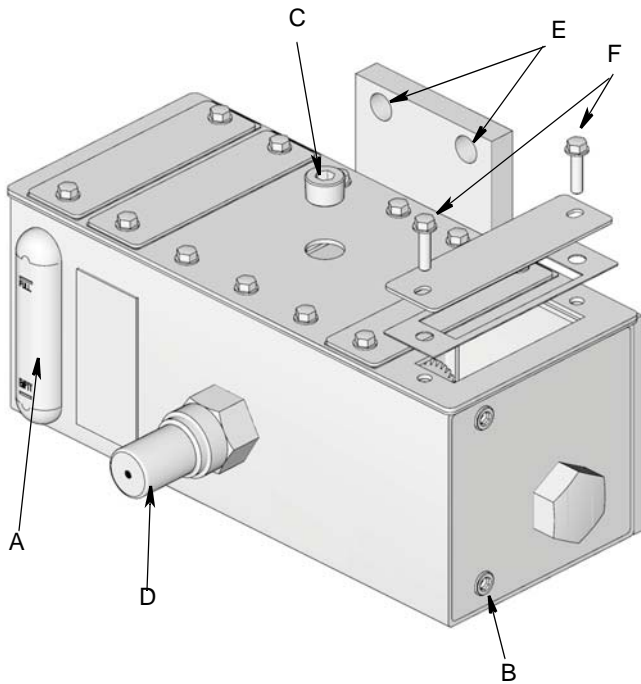

FIG. 1

Key:

- A Sight glass
- B Drain plug
- C Fill plug
- D Drive shaft cover
- E Mounting holes
- F Pump Mounting screws

**The GBL7500 Box Lubricator Pump and GBL Shaft Rotation/Low Level Alarm Pump are available from Graco. See Accessories/Other Accessories, page 10 for information about these pump models and the related instruction manual.*

Grounding

⚠	⚡	⏚				
<p>The equipment must be grounded to reduce the risk of static sparking. Static sparking can cause fumes to ignite or explode. Grounding provides an escape wire for electric current.</p>						

Installation Procedure

Reference letters used in the following instructions, refer to FIG. 1.

1. Select a mounting surface that satisfies the following:
 - Is able to support the weight of the reservoir and fluid when filled to capacity.

NOTE: When possible, mount to a surface that experiences little or no vibration.

 - Allows easy access to the lubricator for filling the reservoir and periodic maintenance.
 - The lubricator must be connected to a ground source.
2. Install reservoir to the mounting surface. See mounting hole layout in the Reservoir and Mounting Dimension section of this manual, page 12.
3. Install bolts through holes (E) in reservoir mounting bracket and tighten securely.
4. Install GBL-7500 pumps into box. Torque mounting bolts (C) to 110 in-lbs ± 10 in-lbs (12.43 N.m ± 1.13 N.m). 1 to 4 pumps can be installed. Refer to GBL-7500 manual for output adjustment and pump information
5. Remove fill plug (C) and fill reservoir with clean, filtered fluid until it reaches the full line on the sight glass. A sight level gauge is provided on the reservoir to monitor the fluid level.

NOTE:

- Filter oil with a minimum 25 micron strainer. Depending on machine requirements it may be necessary to maintain a higher cleanliness level.
- A pump blank is provided to install over all unused pump stations.
- Refer to pump instruction manual for pump **installation and priming** instructions. (See page 10 for Graco pump model information.)

Drive Mechanism



A 1/2 in. diameter shaft is provided to connect the lubricator to a rotary power source.

Install protective guards around all drive components upon installation.

Notice

The maximum recommended speed of the box lubricator input shaft is 1800 rpm. Do not exceed the maximum value of 1800 rpm to avoid box damage.

Operation



Initial Run-In

Fill gear box to “full” line (a) on the sight glass (38) with SAE 30 to SAE 40 weight gear lube. Run the box normally and change gear lube after a 2 week run in period. (FIG. 2)

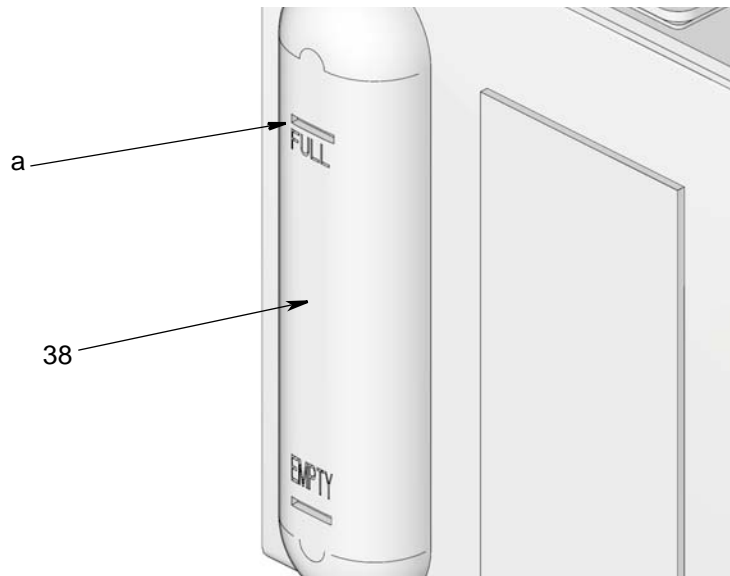

FIG. 2

Refilling/Replacing Gearbox Lube

When necessary, fill the lubricator reservoir with clean filtered lubricant until it reaches the fill line on the sight glass. A sight level gauge is provided on the reservoir to monitor the fluid level. The oil level should not be allowed to drop below the line indicating an empty reservoir. The gearbox lubricant should be checked regularly to ensure proper lubrication of the gearbox. Change fluid annually.

Service/Maintenance

Pressure Relief Procedure



Follow the Pressure Relief Procedure whenever you see this symbol.



This equipment stays pressurized until pressure is manually relieved. To help prevent serious injury from pressurized fluid, such as skin injection, splashing fluid and moving parts, follow the Pressure Relief Procedure in your pump manual when you stop dispensing and before cleaning, checking, or servicing the equipment.

1. Stop lube pump.
 2. If installed, close oil supply valve located upstream from pump.
 3. If installed, open drain valve located downstream from the pump.
- b. Remove all pumping units.
 - c. Clean the pumps and reservoir by brushing loose all foreign matter, dipping in solvent and blowing dry with compressed air.
 - d. Replace pumping units. Torque mounting screws (F) (FIG. 1) to 110 in. lbs \pm 10 in. lbs. (12.43 N.m \pm 1.13 N.m).
 - e. Apply thread sealant (user supplied) to drain plug (C) (FIG. 1) and replace. Torque to 35 in. lbs \pm 5 in. lbs. (3.95 N.m \pm 0.6 N.m).
 - f. Fill reservoir. (See Refilling/Replacing Gearbox Lube, page 6).

Slowly open fluid line fittings to relieve pressure.

1. Follow the **Pressure Relief Procedure** before performing any service procedures.
2. Lubricator operation can be checked by observing the drip tube located within the sight glass well of your pump (if equipped).
 - If the correct pumping rate is maintained, no servicing is required other than periodic replenishment of the reservoir.
 - If the sight glass well pumps dry or no flow is observed refer to the Troubleshooting Section, page 8.
3. Inspect box for worn or damaged components. Replace as necessary.
4. Clean lubricator periodically to eliminate contamination that may have occurred in the oil. To accomplish this:
 - a. Drain reservoir by removing drain plug (C) (FIG. 1). Dispose of oil according to all applicable safety regulations.

Troubleshooting



Problem	Cause	Solution
Sight well pumps dry	Low oil level in reservoir	Add oil. See Refilling the Reservoir, page 6. Check drain plug and tighten if necessary.
No flow from pump outputs	Camshaft not rotating because rotatory power source is defective	Replace rotary power source.
	Broken camshaft	Replace lubricator box.
	Pump issue	Refer to the Troubleshooting Section of your pump instruction manual.
Leaking from under pump	Defective gasket	Replace gasket.
Leaking from reservoir accessory plug	Insufficient thread sealant	Clean and replace thread sealant (user supplied).
Leaking from reservoir drain plug		

Bare Box Parts

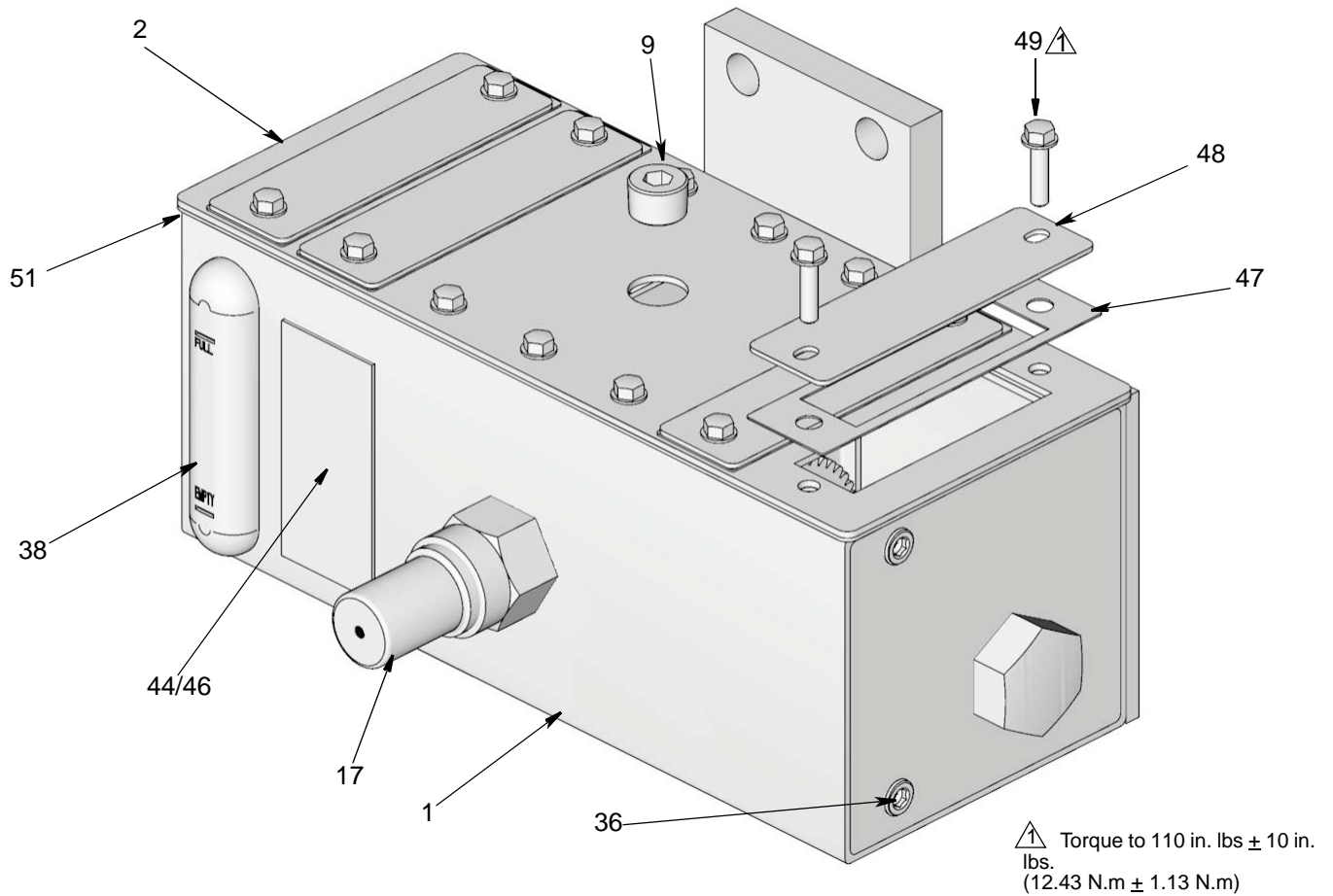

Model: 24N724, 24U750

Ref Part No.	Description	Qty
1	16P865 RESERVOIR	1
2	16P867 COVER, assembly	1
9	260144 PLUG	1
17	556701 DRIVE SHAFT COVER	
36	557391 PLUG, dry seal, 1/4 NPTF	2
38	556697 SIGHTGLASS, level	1
46▲	16P808 LABEL, warning	1
47	556732 GASKET	4
48	557128 PLATE, blankoff	4
49	119426 SCREW, mach, hex washer hd	14
51	16R997 GASKET, cover	1

▲ Replacement Danger and Warning labels, tags, and cards are available at no cost.

Accessories

Pumps* - CE and ATEX certified

Part No.	Description	Special Features / Notes
24J394	3/16 in. Gravity Fed Pump	Not available as a configured option.
24J395	1/4 in. Gravity Fed Pump	Not available as a configured option.
24J396	3/8 in. Gravity Fed Pump	Not available as a configured option.
24J397	3/16 in. Pressure Fed Pump	Not available as a configured option.
24J398	1/4 in. Pressure Fed Pump	Not available as a configured option.
24J399	3/8 in. Pressure Fed Pump	Not available as a configured option.
24K466	Alarm Pump	Not available as a configured option.
		Senses shaft rotation and oil level.
		Pressure switch operation is dependent upon shaft rotation and adequate oil level. NOTE: Pressure switch is not included.

*See pump instruction manual 3A2257.

Other Accessories

Part No.	Description	Special Features/Notes
559307	Gravity Supply	Mounted in the last pump station.
		Exception is when an Alarm Pump is used, then this option is mounted in the second to the last pump station.
563026	Pressurized Supply	Mounted in the last pump station.
		Exception is when an Alarm Pump is used, then this option is mounted in the second to the last pump station.
563013	Low Level Switch	Single-pole, double-throw.
		Meets Explosion Proof Class 1 Group C & D requirements.
		Meets Explosion Proof Class 2 Group E, F & G requirements.
		Mounted in the last pump station. Exception is when an Alarm Pump is used, then this option is mounted in the second to the last pump station.
564015	Low Level Switch	Single-pole, single-throw.
		N.C. Electric Rating is 10 watts @ 120 VAC (minimum).
		Mounted in the last pump station. Exception is when an Alarm Pump is used, then this option is mounted in the second to the last pump station.

Technical Data

Center Drive Box Lubricator		
	US	Metric
Pump Size	Maximum Outlet Pressure	Maximum Outlet Pressure
3/16"	7500 psi	51.71 MPa 517.1 bar
1/4"	6000 psi	41.37 MPa 413.7 bar
3/8"	2500 psi	17.24 MPa 172.4 bar
Temperature		
Operating Temperature Range	-20°F to 140°F	(-29°C to 60°C)
Fluid Viscosity		
Dispensing Fluid Viscosity	80 to 5000 SUS	
Materials of Constructions		
Wetted Materials	carbon steel, nylon, fluoroelastomer, cork, brass, aluminum	
Drive Speed		
Drive Speed	1800 rpm max	

Reservoir and Mounting Dimensions

Dimensions are shown in inches (mm).

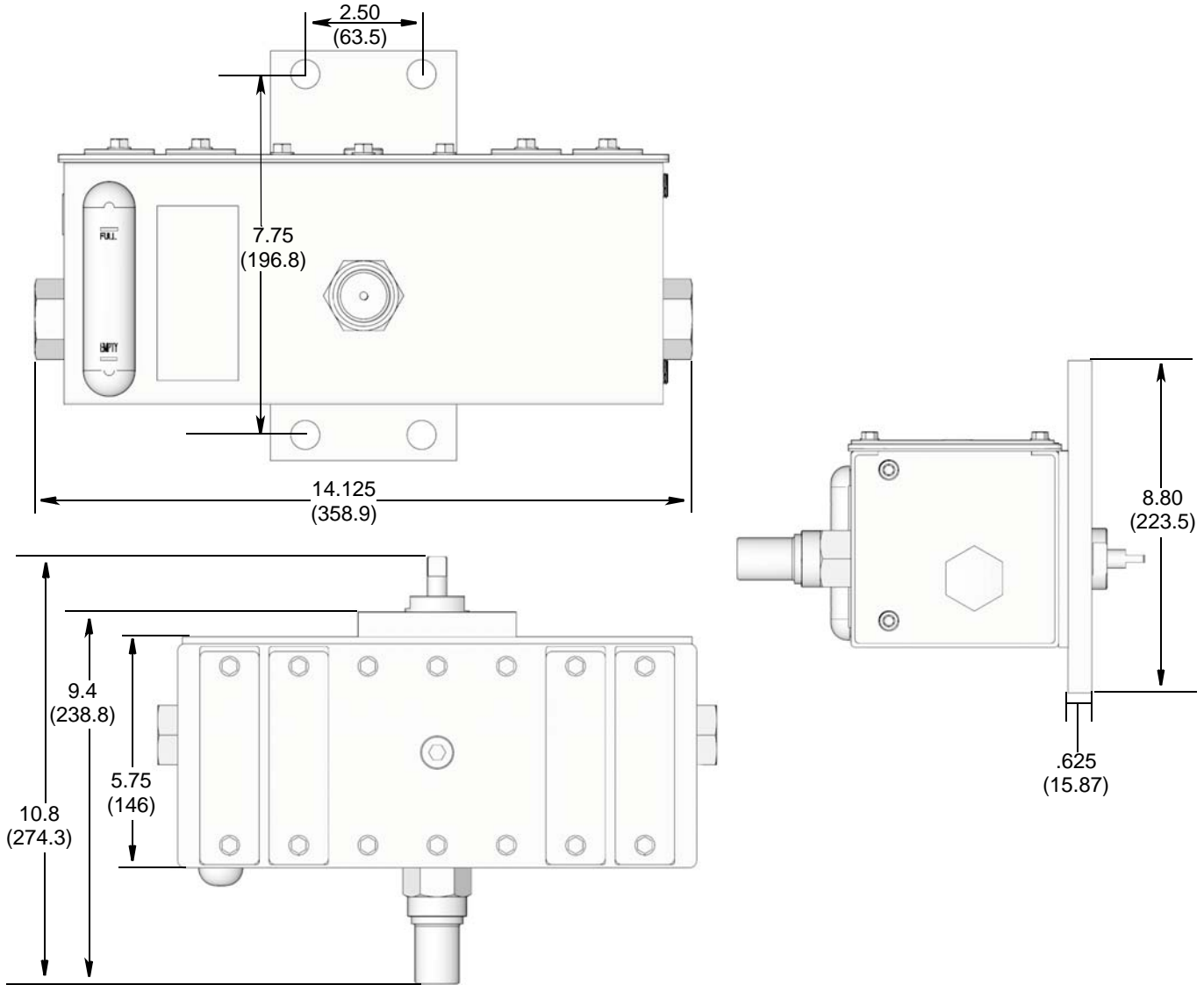

Dimensions: 4 Position, 60:1

Graco Standard Warranty

Graco warrants all equipment referenced in this document which is manufactured by Graco and bearing its name to be free from defects in material and workmanship on the date of sale to the original purchaser for use. With the exception of any special, extended, or limited warranty published by Graco, Graco will, for a period of twelve months from the date of sale, repair or replace any part of the equipment determined by Graco to be defective. This warranty applies only when the equipment is installed, operated and maintained in accordance with Graco's written recommendations.

This warranty does not cover, and Graco shall not be liable for general wear and tear, or any malfunction, damage or wear caused by faulty installation, misapplication, abrasion, corrosion, inadequate or improper maintenance, negligence, accident, tampering, or substitution of non-Graco component parts. Nor shall Graco be liable for malfunction, damage or wear caused by the incompatibility of Graco equipment with structures, accessories, equipment or materials not supplied by Graco, or the improper design, manufacture, installation, operation or maintenance of structures, accessories, equipment or materials not supplied by Graco.

This warranty is conditioned upon the prepaid return of the equipment claimed to be defective to an authorized Graco distributor for verification of the claimed defect. If the claimed defect is verified, Graco will repair or replace free of charge any defective parts. The equipment will be returned to the original purchaser transportation prepaid. If inspection of the equipment does not disclose any defect in material or workmanship, repairs will be made at a reasonable charge, which charges may include the costs of parts, labor, and transportation.

THIS WARRANTY IS EXCLUSIVE, AND IS IN LIEU OF ANY OTHER WARRANTIES, EXPRESS OR IMPLIED, INCLUDING BUT NOT LIMITED TO WARRANTY OF MERCHANTABILITY OR WARRANTY OF FITNESS FOR A PARTICULAR PURPOSE.

Graco's sole obligation and buyer's sole remedy for any breach of warranty shall be as set forth above. The buyer agrees that no other remedy (including, but not limited to, incidental or consequential damages for lost profits, lost sales, injury to person or property, or any other incidental or consequential loss) shall be available. Any action for breach of warranty must be brought within two (2) years of the date of sale.

GRACO MAKES NO WARRANTY, AND DISCLAIMS ALL IMPLIED WARRANTIES OF MERCHANTABILITY AND FITNESS FOR A PARTICULAR PURPOSE, IN CONNECTION WITH ACCESSORIES, EQUIPMENT, MATERIALS OR COMPONENTS SOLD BUT NOT MANUFACTURED BY GRACO. These items sold, but not manufactured by Graco (such as electric motors, switches, hose, etc.), are subject to the warranty, if any, of their manufacturer. Graco will provide purchaser with reasonable assistance in making any claim for breach of these warranties.

In no event will Graco be liable for indirect, incidental, special or consequential damages resulting from Graco supplying equipment hereunder, or the furnishing, performance, or use of any products or other goods sold hereto, whether due to a breach of contract, breach of warranty, the negligence of Graco, or otherwise.

FOR GRACO CANADA CUSTOMERS

The Parties acknowledge that they have required that the present document, as well as all documents, notices and legal proceedings entered into, given or instituted pursuant hereto or relating directly or indirectly hereto, be drawn up in English. Les parties reconnaissent avoir convenu que la rédaction du présente document sera en Anglais, ainsi que tous documents, avis et procédures judiciaires exécutés, donnés ou intentés, à la suite de ou en rapport, directement ou indirectement, avec les procédures concernées.

Graco Information

For the latest information about Graco products, visit www.graco.com.

TO PLACE AN ORDER, contact your Graco distributor or call to identify the nearest distributor.

Phone: 612-623-6928 **or Toll Free:** 1-800-533-9655, **Fax:** 612-378-3590

*All written and visual data contained in this document reflects the latest product information available at the time of publication.
Graco reserves the right to make changes at any time without notice.*

For patent information, see www.graco.com/patents.

Original instructions. This manual contains English. MM 3A2953

Graco Headquarters: Minneapolis

International Offices: Belgium, China, Japan, Korea

GRACO INC. AND SUBSIDIARIES • P.O. BOX 1441 • MINNEAPOLIS MN 55440-1441 • USA

Copyright 2012, Graco Inc. All Graco manufacturing locations are registered to ISO 9001.

www.graco.com

September 2012, revised June 2016