

Repair/Parts



Husky™ 1050HP 2:1

Air-Operated Diaphragm Pump

334390B
EN

1-inch high-pressure pump with modular air valve for fluid transfer applications. For professional use only.



Important Safety Instructions

Read all warnings and instructions in this manual and in your Operation manual. **Save these instructions.**

Maximum Fluid Working Pressure:
250 psi (1.72 MPa, 17.2 bar)

Maximum Air Input Pressure:
125 psi (0.86 MPa, 8.6 bar)

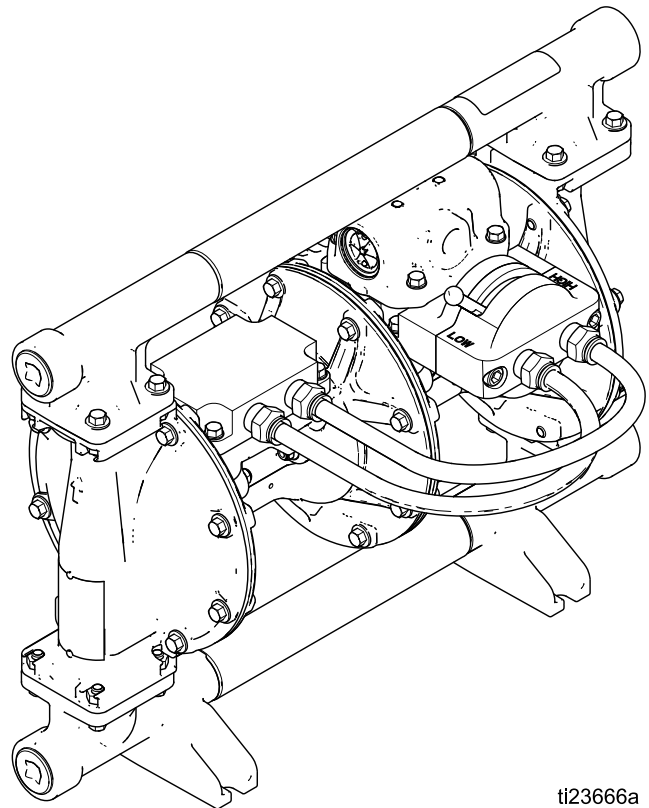

ti23666a



PROVEN QUALITY. LEADING TECHNOLOGY.

Contents

Related Manuals	2	Check Valve Repair	16
Ordering Information	3	Diaphragm and Center Section Repair	17
Configuration Number Matrix	4	Torque Instructions	24
Warnings	5	Notes	25
Troubleshooting	8	Parts	26
Repair	10	Notes	45
Pressure Relief Procedure	10	Technical Data	46
Replace Complete Air Valve	10	Fluid Temperature Range	47
Replace Seals or Rebuild Air Valve	12	Graco Standard Husky Pump Warranty	48
Replace Complete High/Low Valve	14		
Replace Seals or Rebuild the High/Low Valve	15		

Related Manuals

Manual No.	Description
334014	Husky 1050HP 2:1 Air-Operated Diaphragm Pump, Operation

Ordering Information

To Find Your Nearest Distributor

1. Visit www.graco.com.
2. Click on **Where to Buy** and use the **Distributor Locator**.

To Specify the Configuration of a New Pump

Please call your distributor.

To Order Replacement Parts

Please call your distributor.

Distributor Note

1. To find part numbers for replacement parts:
 - a. Use the 20–digit number from the ID plate on the pump.
 - b. Use the Configuration Number Matrix on the next page to understand which parts are described by each digit.
 - c. Refer to the main Parts illustration and to the Parts/Kits Quick Reference. Follow the page references on these two pages for further ordering information, as needed.
2. Please call Graco Customer Service to order.

Configuration Number Matrix

Check the identification plate (ID) for the 20-digit Configuration Number of your pump. Use the following matrix to define the components of your pump.

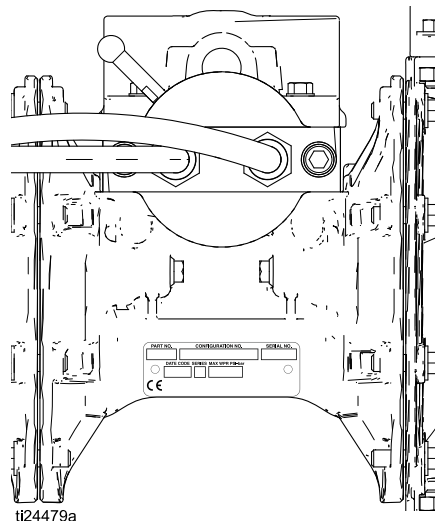

Sample Configuration Number:







1050HP	A01A	A1	SS	SP	SP	PT
Pump Model	Center Section and Air Valve	Manifolds	Seats	Balls	Diaphragms	Manifold O-Rings







Pump	Center Section and Air Valve Material		Air Valve	Manifolds	
1050HP Aluminum	Aluminum	A01A	Standard	A1	Aluminum, standard ports, npt
				A2	Aluminum, standard ports, bsp
				S1	Stainless steel, standard ports, npt
				S2	Stainless steel, standard ports, bsp







Check Valve Seats		Check Valve Balls		Diaphragm Material		Manifold O-Rings	
GE	Geolast®	CW	Polychloroprene Weighted	BN	Buna-N	PT	PTFE
SP	Santoprene®	GE	Geolast	CO	Polychloroprene Overmolded		
SS	316 Stainless Steel	SP	Santoprene	PT	PTFE/Santoprene Two-Piece		
		SS	316 Stainless Steel	SP	Santoprene		

Warnings

The following warnings are for the setup, use, grounding, maintenance, and repair of this equipment. The exclamation point symbol alerts you to a general warning and the hazard symbols refer to procedure-specific risks. When these symbols appear in the body of this manual or on warning labels, refer back to these Warnings. Product-specific hazard symbols and warnings not covered in this section may appear throughout the body of this manual where applicable.

 <h2 style="margin: 0;">WARNING</h2>	
   	<p>FIRE AND EXPLOSION HAZARD</p> <p>Flammable fumes, such as solvent and paint fumes, in work area can ignite or explode. To help prevent fire and explosion:</p> <ul style="list-style-type: none"> • Use equipment only in well ventilated area. • Eliminate all ignition sources; such as pilot lights, cigarettes, portable electric lamps, and plastic drop cloths (potential static arc). • Keep work area free of debris, including solvent, rags and gasoline. • Do not plug or unplug power cords, or turn power or light switches on or off when flammable fumes are present. • Ground all equipment in the work area. See Grounding instructions. • Use only grounded hoses. • Stop operation immediately if static sparking occurs or you feel a shock. Do not use equipment until you identify and correct the problem. • Keep a working fire extinguisher in the work area. • Route exhaust away from all ignition sources. If diaphragm ruptures, fluid may be exhausted with air.
 	<p>PRESSURIZED EQUIPMENT HAZARD</p> <p>Fluid from the equipment, leaks, or ruptured components can splash in the eyes or on skin and cause serious injury.</p> <ul style="list-style-type: none"> • Follow the Pressure Relief Procedure when you stop spraying/dispensing and before cleaning, checking, or servicing equipment. • Tighten all fluid connections before operating the equipment. • Check hoses, tubes, and couplings daily. Replace worn or damaged parts immediately.

 <h1 style="margin: 0;">WARNING</h1>	
 	<p>EQUIPMENT MISUSE HAZARD</p> <p>Misuse can cause death or serious injury.</p> <ul style="list-style-type: none"> • Do not operate the unit when fatigued or under the influence of drugs or alcohol. • Do not exceed the maximum working pressure or temperature rating of the lowest rated system component. See Technical Data in all equipment manuals. • Use fluids and solvents that are compatible with equipment wetted parts. See Technical Data in all equipment manuals. Read fluid and solvent manufacturer’s warnings. For complete information about your material, request MSDS from distributor or retailer. • Do not leave the work area while equipment is energized or under pressure. • Turn off all equipment and follow the Pressure Relief Procedure when equipment is not in use. • Check equipment daily. Repair or replace worn or damaged parts immediately with genuine manufacturer’s replacement parts only. • Do not alter or modify equipment. Alterations or modifications may void agency approvals and create safety hazards. • Make sure all equipment is rated and approved for the environment in which you are using it. • Use equipment only for its intended purpose. Call your distributor for information. • Route hoses and cables away from traffic areas, sharp edges, moving parts, and hot surfaces. • Do not kink or over bend hoses or use hoses to pull equipment. • Keep children and animals away from work area. • Comply with all applicable safety regulations.
	<p>PRESSURIZED ALUMINUM PARTS HAZARD</p> <p>Use of fluids that are incompatible with aluminum in pressurized equipment can cause serious chemical reaction and equipment rupture. Failure to follow this warning can result in death, serious injury, or property damage.</p> <ul style="list-style-type: none"> • Do not use 1,1,1-trichloroethane, methylene chloride, other halogenated hydrocarbon solvents or fluids containing such solvents. • Do not use chlorine bleach. • Many other fluids may contain chemicals that can react with aluminum. Contact your material supplier for compatibility.
  	<p>THERMAL EXPANSION HAZARD</p> <p>Fluids subjected to heat in confined spaces, including hoses, can create a rapid rise in pressure due to the thermal expansion. Over-pressurization can result in equipment rupture and serious injury.</p> <ul style="list-style-type: none"> • Open a valve to relieve the fluid expansion during heating. • Replace hoses proactively at regular intervals based on your operating conditions.

 <h1 style="margin: 0;">WARNING</h1>	
 	<p>PLASTIC PARTS CLEANING SOLVENT HAZARD</p> <p>Many solvents can degrade plastic parts and cause them to fail, which could cause serious injury or property damage.</p> <ul style="list-style-type: none"> • Use only compatible water-based solvents to clean plastic structural or pressure-containing parts. • See Technical Data in this and all other equipment instruction manuals. Read fluid and solvent manufacturer's MSDSs and recommendations.
 	<p>TOXIC FLUID OR FUMES HAZARD</p> <p>Toxic fluids or fumes can cause serious injury or death if splashed in the eyes or on skin, inhaled, or swallowed.</p> <ul style="list-style-type: none"> • Read MSDSs to know the specific hazards of the fluids you are using. • Route exhaust away from work area. If diaphragm ruptures, fluid may be exhausted into the air. • Store hazardous fluid in approved containers, and dispose of it according to applicable guidelines.
	<p>BURN HAZARD</p> <p>Equipment surfaces and fluid that's heated can become very hot during operation. To avoid severe burns:</p> <ul style="list-style-type: none"> • Do not touch hot fluid or equipment.
	<p>PERSONAL PROTECTIVE EQUIPMENT</p> <p>Wear appropriate protective equipment when in the work area to help prevent serious injury, including eye injury, hearing loss, inhalation of toxic fumes, and burns. This protective equipment includes but is not limited to:</p> <ul style="list-style-type: none"> • Protective eyewear, and hearing protection. • Respirators, protective clothing, and gloves as recommended by the fluid and solvent manufacturer.

Troubleshooting



Problem	Cause	Solution
Pump cycles but will not prime.	Pump is running too fast, causing cavitation before prime.	Reduce air inlet pressure.
	Check valve ball severely worn or wedged in seat or manifold.	Replace ball and seat.
	Seat severely worn.	Replace ball and seat.
	Outlet or inlet clogged.	Unclog.
	Inlet or outlet valve closed.	Open.
	Inlet fittings or manifolds loose.	Tighten.
	Manifold o-rings damaged.	Replace o-rings.
Pump cycles at stall or fails to hold pressure at stall.	Worn check valve balls, seats, or o-rings.	Replace.
Pump will not cycle, or cycles once and stops.	Air valve is stuck or dirty.	Disassemble and clean air valve. Use filtered air.
	Check valve ball severely worn and wedged in seat or manifold.	Replace ball and seat.
	Pilot valve worn, damaged, or plugged.	Replace pilot valve.
	Air valve gasket damaged.	Replace gasket.
	Dispensing valve clogged.	Relieve pressure and clear valve.
	High/Low valve shift lever is not fully seated into the High or Low position.	Shift lever all the way into either High or Low position.
Pump operates erratically.	Clogged suction line.	Inspect; clear.
	Sticky or leaking check valve balls.	Clean or replace.
	Diaphragm ruptured.	Replace.
	Restricted exhaust.	Remove restriction.
	Pilot valves damaged or worn.	Replace pilot valves.
	Air valve damaged.	Replace air valve.
	Air valve gasket damaged.	Replace air valve gasket.
	Air supply erratic.	Repair air supply.
Exhaust muffler icing.	Use drier air supply.	

Problem	Cause	Solution
Air bubbles in fluid.	Suction line is loose.	Tighten.
	Diaphragm ruptured.	Replace.
	Loose manifolds, damaged seats or o-rings.	Tighten manifold bolts or replace seats or o-rings.
	Pump cavitation.	Reduce pump speed or suction lift.
	Loose diaphragm shaft bolt.	Tighten.
Exhaust air contains fluid being pumped.	Diaphragm ruptured.	Replace.
	Loose diaphragm shaft bolt.	Tighten or replace.
Moisture in exhaust air.	High inlet air humidity.	Use drier air supply.
Pump exhausts excessive air at stall.	Worn air valve cup or plate.	Replace cup and plate.
	Damaged air valve gasket.	Replace gasket.
	Damaged pilot valve.	Replace pilot valves.
	Worn shaft seals or bearings.	Replace shaft seals or bearings.
Pump leaks air externally.	Air valve or fluid cover screws loose.	Tighten.
	Diaphragm damaged.	Replace diaphragm.
	Air valve gasket damaged.	Replace gasket.
	High/Low valve shift lever is not fully seated into the High or Low position.	Shift the lever all the way into either High or Low position.
Pump leaks fluid externally from joints.	Loose manifold screws or fluid cover screws.	Tighten manifold screws or fluid cover screws.
	Manifold o-rings worn out.	Replace o-rings.
Pump will operate in the Low pressure setting, but will not operate in the High pressure setting.	The hoses for the High/Low valve are not installed correctly.	Install hoses as shown in the figure on page 10.

Repair

Pressure Relief Procedure



Follow the Pressure Relief Procedure whenever you see this symbol.



This equipment stays pressurized until pressure is relieved manually. To help prevent serious injury from pressurized fluid, such as splashing in the eyes or on skin, follow the Pressure Relief Procedure when you stop pumping and before you clean, check, or service the equipment.

1. Shut off the air supply to the pump.
2. Open the dispensing valve, if used.
3. Shift the High/Low pressure lever back and forth two times. Leave the lever in the “Low” position as shown in Fig. 1.

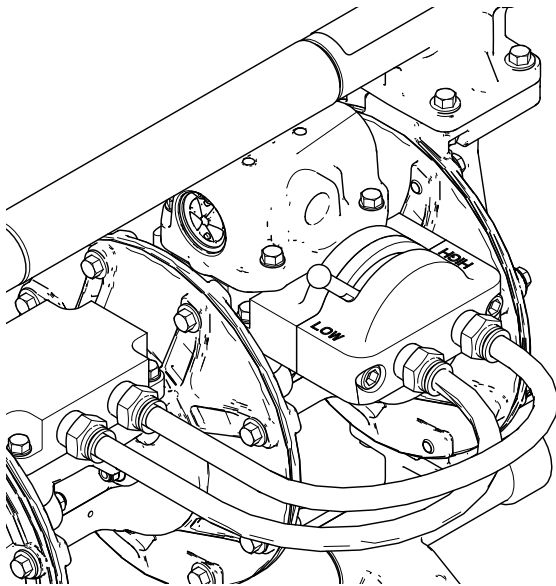

ti23687a

Figure 1 High/Low Pressure Lever

4. Open the fluid drain valve (installed on the system) to relieve all fluid pressure. Have a container ready to catch the drainage.

Replace Complete Air Valve

Follow these instructions to install Air Valve Replacement 24W897.

1. Stop the pump. Follow the **Pressure Relief Procedure** in the previous section.
2. Disconnect the main air line.
3. Remove four screws (217). Remove the air valve (212). Remove the six o-rings (208, 209, and 210).
4. To repair the air valve, go to **Disassemble the Air Valve**, step 2, in the next section. To install a replacement air valve, continue with step 5.
5. Install the new o-rings (208, 209, and 210) on the High/Low manifold, then attach the air valve. Apply thread lubricant and torque screws (217) to 80 in-lb (9 N•m).
6. Reconnect the main air line.

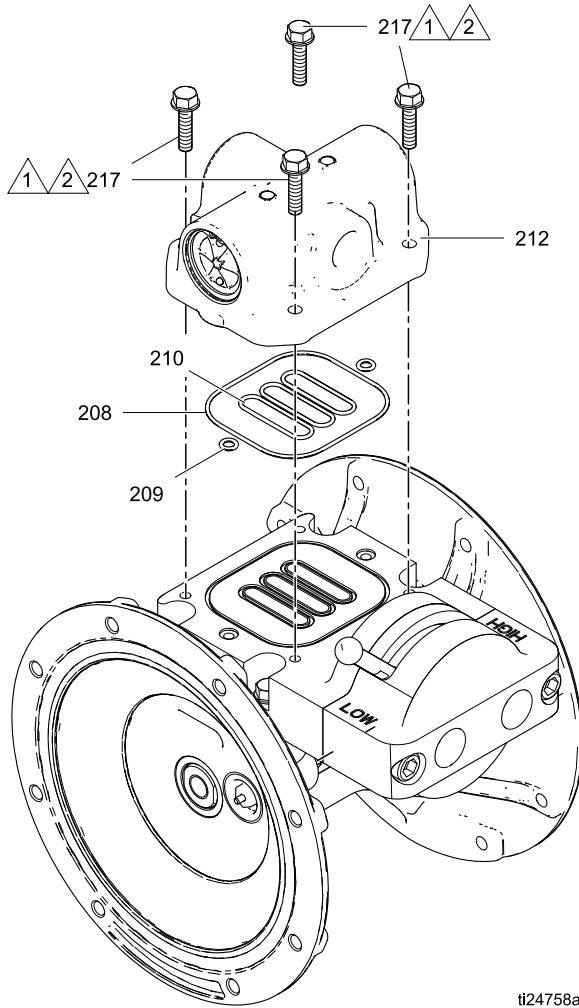

Apply thread lubricant to threads before assembly.



Torque screws to 80 in-lb (9 N•m).

ti24758a

Replace Seals or Rebuild Air Valve

Follow these instructions to service the air valve with one of the available repair kits. Air Valve Seal Kit parts are marked with a †. Air Valve Repair Kit parts are marked with a ♦. Air Valve End Cap Kit parts are marked with a ‡. Kit 24W952 also is available to replace the 6 o-rings between the air valve and the High/Low manifold.

Disassemble the Air Valve

1. Perform steps 1-3 under [Replace Complete Air Valve, page 10](#).
2. Use a T8 Torx screwdriver to remove two screws (309). Remove the valve plate (305), cup assembly (312-314), spring (311), and detent assembly (303).
3. Pull the cup (313) off of the base (312). Remove the o-ring (314) from the cup.
4. Remove the retaining ring (310) from each end of the air valve. Use the piston (302) to push the end cap (307) out of one end. Remove the u-cup seal (308) from the piston. Pull the piston out of the end and remove the other u-cup seal (308). Remove the other end cap (307) and the end cap o-rings (306).
5. Remove the detent cam (304) from the air valve housing (301).

Reassemble the Air Valve

NOTE: Apply lithium-based grease when instructed to grease. Order Graco PN 111920.

1. Use all parts in the repair kits. Clean other parts and inspect for damage. Replace as needed.
2. Grease the detent cam (304♦) and install into housing (301).
3. Grease the u-cups (308♦†) and install on the piston with lips facing toward the center of the piston.

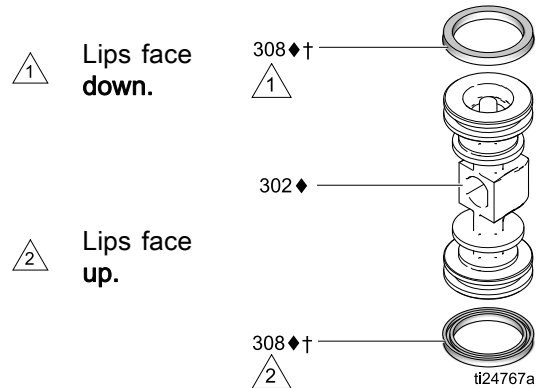

4. Grease both ends of the piston (302♦) and the housing bore. Install the piston in the housing (301), with the flat side toward the cup (313♦). Be careful not to tear u-cups (308♦†) when sliding piston into housing.
5. Grease new o-rings (306♦†‡) and install on the end caps (307‡). Install the end caps into the housing.
6. Install a retaining ring (310‡) on each end to hold end caps in place.

- Grease and install the detent assembly (303♦) into the piston. Install the o-ring (314♦) on the cup (313♦). Apply a light film of grease to the outside surface of the o-ring and the inside mating surface of the base (312♦). Orient the end of the base that has a magnet toward the end of the cup that has the larger cutout. Engage the opposite end of the parts. Leave the end with the magnet free. Tilt the base toward the cup and fully engage the parts, using care so that the o-ring remains in place. Install the spring (311♦) onto the protrusion on the cup. Align the magnet in the base with the air inlet and install the cup assembly.

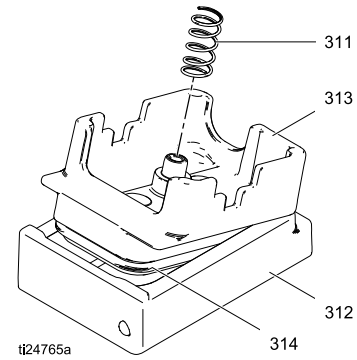

- Grease the cup side and install the valve plate (305♦). Align the small hole in the plate with the air inlet. Tighten the screws (309♦†) to hold it in place.
- Follow steps 5–6 under [Replace Complete Air Valve, page 10](#), to replace the seals and reattach the air valve.

- 1 Apply lithium-based grease.
- 2 U-cup lips must face piston.
- 3 Apply lithium-based grease to contact surface.
- 4 Air inlet.

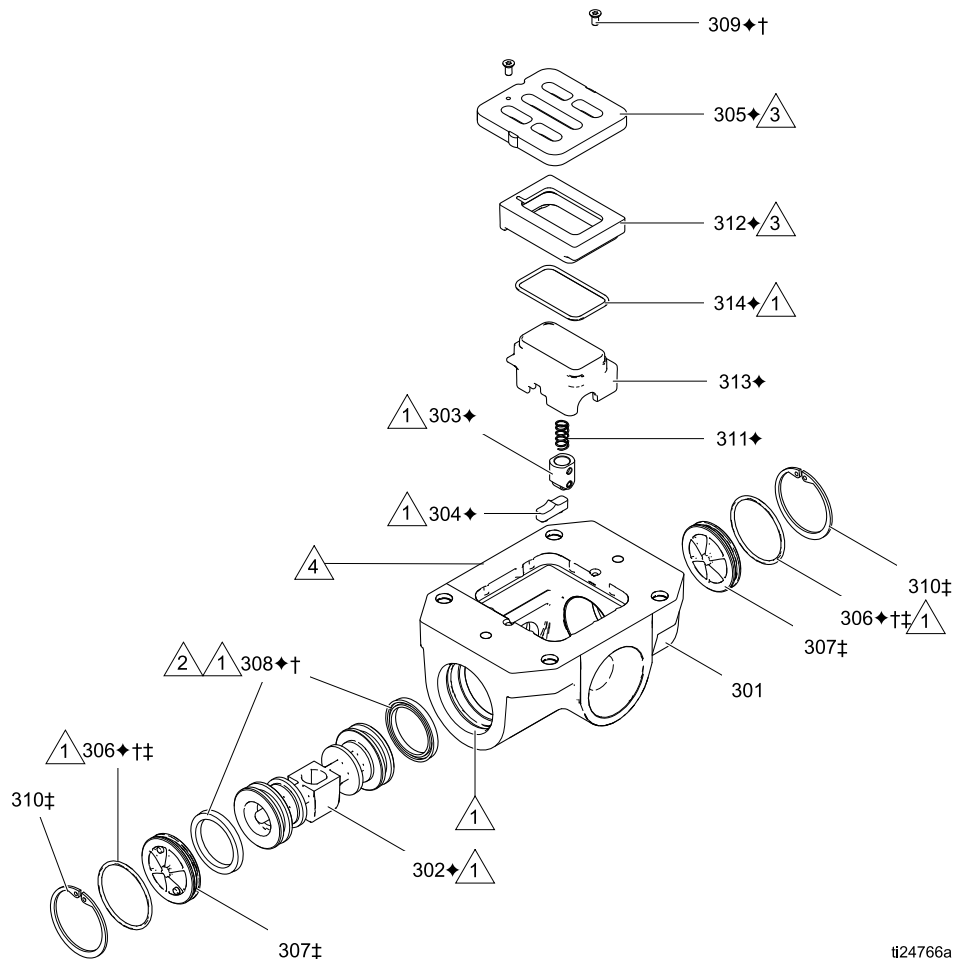

Replace Complete High/Low Valve

1. Stop the pump. Follow the [Pressure Relief Procedure, page 10](#).
2. Disconnect the main air line. Release the quick disconnect fittings to remove the air manifold hoses (108).
3. To repair the High/Low valve, go to **Disassemble the High/Low Valve**, step 2, in the next section. To install a replacement High/Low valve, continue with step 4.
4. Remove four screws (217). Remove the air valve (212). Remove the six o-rings (208, 209, and 210).
5. Remove four screws (217). Remove the High/Low valve (211) and gasket (213).
6. Align the new gasket (213) on the primary center section, then attach the new High/Low valve (211). Apply thread lubricant and torque screws (217) to 80 in-lb (9 N•m).
7. Install the new o-rings (208, 209, and 210) on the High/Low manifold, then attach the air valve. Apply thread lubricant and torque screws (217) to 80 in-lb (9 N•m).
8. Reconnect the main air line and the air manifold hoses (108).

 Apply thread lubricant to threads before assembly.

 Torque screws to 80 in-lb (9 N•m).

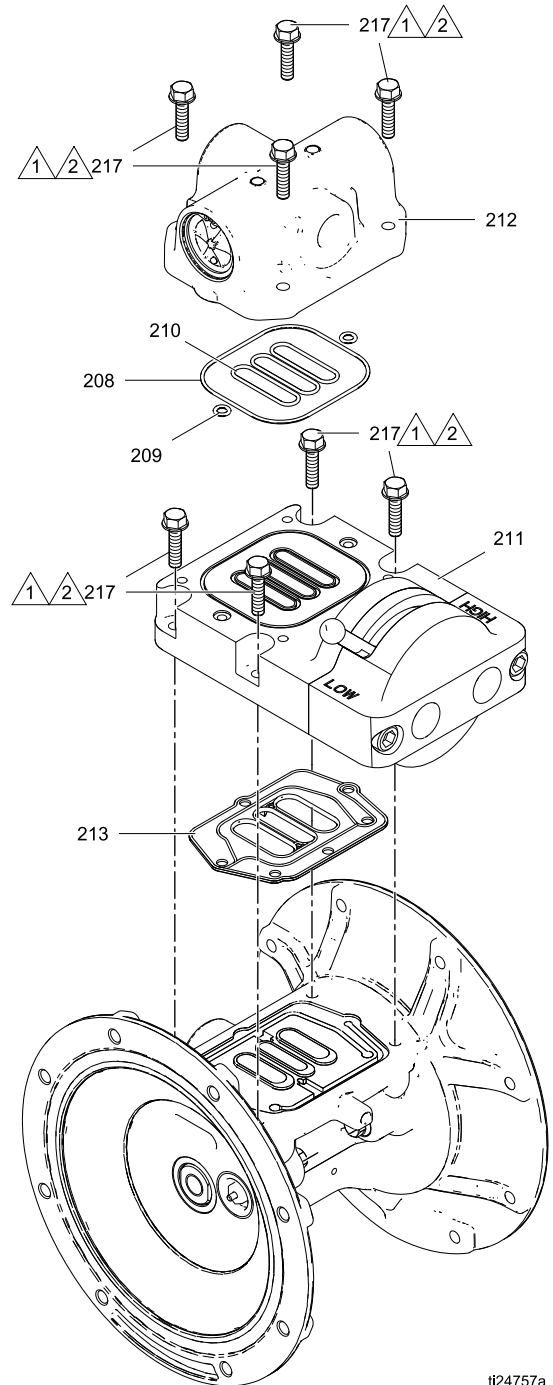

ti24757a

Replace Seals or Rebuild the High/Low Valve

Follow these instructions to service the High/Low valve. High/Low Valve Seal Kit 24W949 is available to replace o-rings 402 and 405. Kit 24W952 also is available to replace the 6 o-rings between the air valve and the High/Low manifold. Kit 24W950 is available to replace the spool (404).

Disassemble the High/Low Valve

1. Follow steps 1 and 2 under [Replace Complete High/Low Valve, page 14](#).
2. Use a 5/16 in Allen wrench to remove two screws (407).
3. Remove the High/Low valve (406). Unscrew the handle (403) from the spool (404), then remove the spool. Use an o-ring pick to remove all o-rings (402 and 405) from the spool.

NOTE: The High/Low manifold block does not have to be removed from the primary center section.

Reassemble the High/Low Valve

NOTE: Apply lithium-based grease when instructed to grease.

1. Use all parts in the seal kit. Clean other parts and inspect for damage. Replace as needed.
2. Grease two o-rings (402) and install them in the manifold block (401).

3. Grease and install three o-rings (402 and 405) on the spool (404).
4. Grease the outside edge, then install the spool (404) in the High/Low valve (406). Install the lever (403).
5. Use two screws (407) to reattach the High/Low valve. Torque to 340–360 in-lb (38–41 N•m).
6. Reconnect the main air line and the air manifold hoses (108).

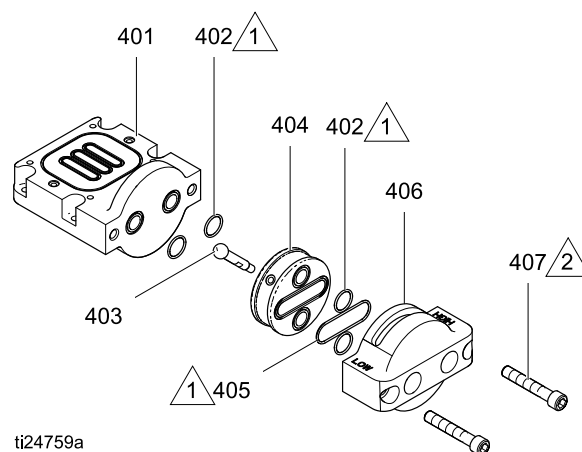

Apply lithium-based grease.



Torque to 340–360 in-lb (38–41 N•m).

Check Valve Repair

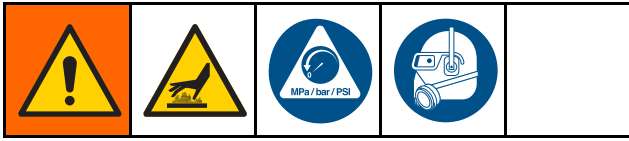

NOTE: Kits are available for new check valve balls and seats. See [Seats and Check Balls](#) to order kits in the material(s) desired. O-ring and fastener kits also are available.

NOTE: To ensure proper seating of the check balls, always replace the seats when replacing the balls. Also, replace the o-rings every time the manifold is removed.

Disassemble the Check Valve

1. Follow the [Pressure Relief Procedure, page 10](#). Disconnect all hoses.
2. Remove the pump from its mounting.
3. Use a 10 mm socket wrench to remove the manifold fasteners (5), then remove the outlet manifold (3).
4. Remove the o-rings (9), seats (7), and balls (8).
5. Remove the nuts (27).
6. Turn the pump over and remove the inlet manifold (4).
7. Remove the o-rings (9), seats (7), and balls (8).

Reassemble the Check Valve

1. Clean all parts and inspect for wear or damage. Replace parts as needed.
2. Reassemble in the reverse order, following all notes in the illustration. Put the inlet manifold on first. Be sure the ball checks (7-9) and manifolds (3, 4) are assembled **exactly** as shown. The ball must seat on the chamfered side of the seat. The arrows (A) on the fluid covers (2) **must** point toward the outlet manifold (3).

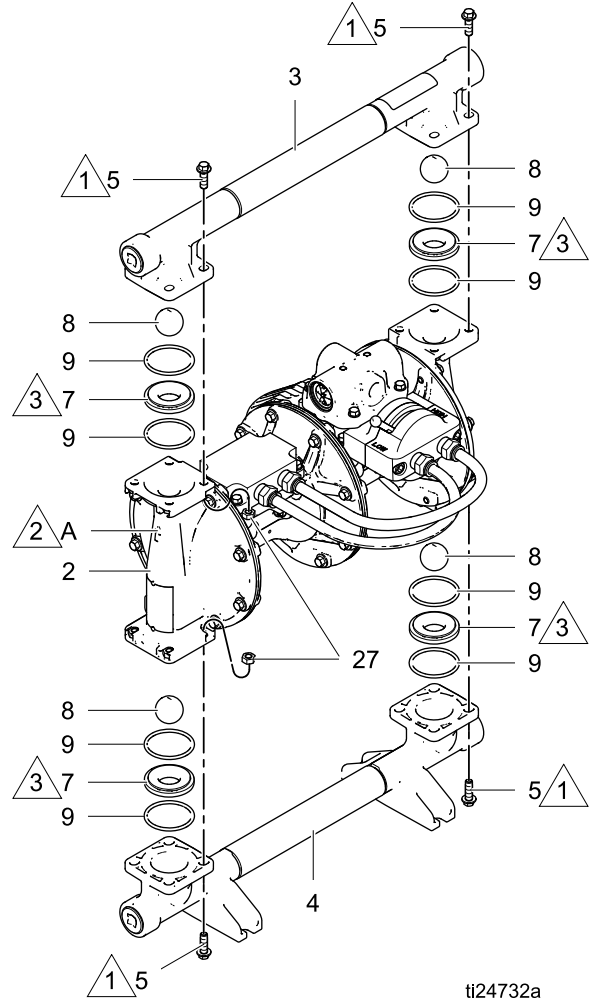

ti24732a

Figure 2 Check valve assembly

- 1 Torque to 100 in-lb (11.3 N·m). Follow torque sequence. See [Torque Instructions, page 24](#).
- 2 Arrow (A) must point toward outlet manifold
- 3 The chamfered side of the seat must face the ball.

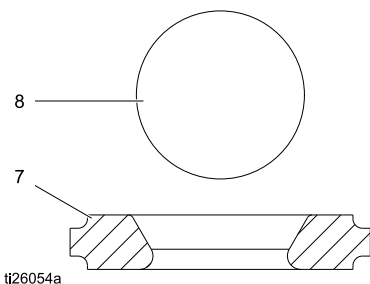

ti26054a

Diaphragm and Center Section Repair

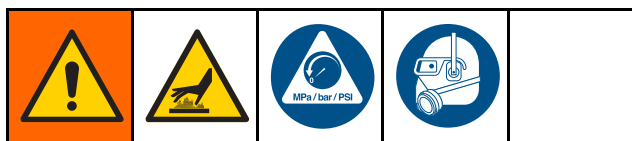

NOTE: See [Diaphragms](#) for replacement diaphragm kits. Center Rebuild Kit 24W946 also is available. Parts included in the Center Rebuild Kit are marked with an *. For best results, use all kit parts.

Disassemble the Fluid Diaphragms

1. Follow the [Pressure Relief Procedure](#), page 10.
2. Remove the manifolds and disassemble the ball check valves as explained in [Check Valve Repair](#), page 16.
3. Remove the muffler (18).
4. Use a 10 mm socket wrench to remove the fluid cover screws (5), then remove the fluid covers (2).
5. **Bolt-Through Diaphragms:** Use a 15 mm socket wrench to remove the diaphragm shaft bolt (14) on one side of the pump. If the shaft (206) remains attached to the bolt, use a wrench on the flats of the shaft to remove it. Then, remove all parts of that diaphragm assembly.
Overmolded Diaphragms: The diaphragm (12) on one side of the pump will screw off by hand. The diaphragm setscrew should remain attached to the diaphragm. If the shaft (206) remains attached to the diaphragm setscrew, use a wrench on the flats of the shaft to remove it. Remove the air side diaphragm plate (11).
6. Repeat for the other diaphragm.

Disassemble the Center Section

1. Use a 10 mm socket wrench to remove the screws (5), then separate the primary air module (101) from the secondary air module (102).
2. Remove the diaphragm (109), the air plates (103 and 105), and the set screw (104).
3. Inspect the diaphragm shafts (206) for wear or scratches. If damaged, inspect the bearings (203) in place. If they are damaged, use a bearing puller to remove them.

NOTE: Do not remove undamaged bearings.

4. Use an o-ring pick to remove the u-cup packings (202) from the primary air module and the secondary air module. Bearings (203) can remain in place.
5. If necessary, use a box end wrench to remove the pilot valves (205, primary air module) or the secondary pilot plugs (220, secondary air module).
6. Remove the pilot valve cartridges only if necessary due to a known or suspected problem. **After removing pilot valves (primary side) or secondary pilot plugs (secondary side)**, use a hex to remove the cartridges (204), then remove cartridge o-rings (219). If stripped, cross two screwdrivers in the shape of an X. Insert the blades into the area around the 10 mm hex. Revolve the blades against each other while holding the tips against the outer area of the recess to unscrew the cartridge.

NOTE: Do not remove undamaged pilot valve cartridges.

Reassemble the Center Section

Follow all notes in the illustrations. These notes contain **important** information.

NOTE: Apply lithium-based grease whenever instructed to grease.

1. Clean all parts and inspect for wear or damage. Replace parts as needed.

NOTE: Follow Steps 2–5 for both the **Primary Air Module** and the **Secondary Air Module**.

2. If removed, grease and install the new pilot valve cartridges (204*) and cartridge o-rings (219*). Screw in until seated.

NOTE: Cartridges (204*) must be installed before pilot valves (205*) or secondary pilot plugs (220*).

3. Grease and install the pilot valves (205*, primary side) or secondary pilot plugs (220*, secondary side). Torque to 20–25 in-lb (2–3 N•m) at 100 rpm maximum. Do not overtorque.
4. Grease and install the diaphragm shaft u-cup packings (202*) so the lips face out of the housing.
5. If removed, insert the new bearings (203*) into the primary air module and/or the secondary air module. Use a press or a block and rubber mallet to press-fit the bearing so it is flush with the surface of the module.

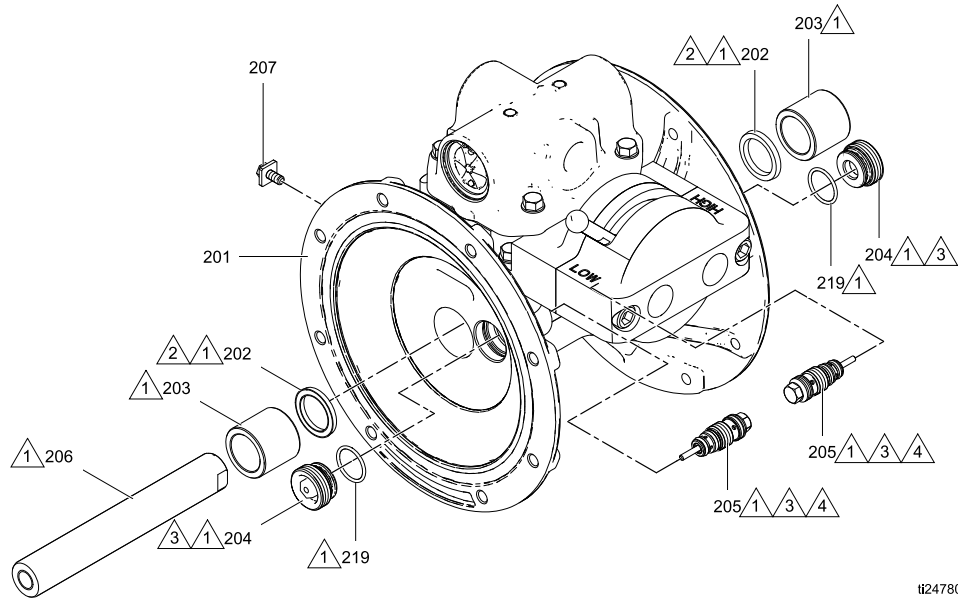

Primary Air Module

t24780a

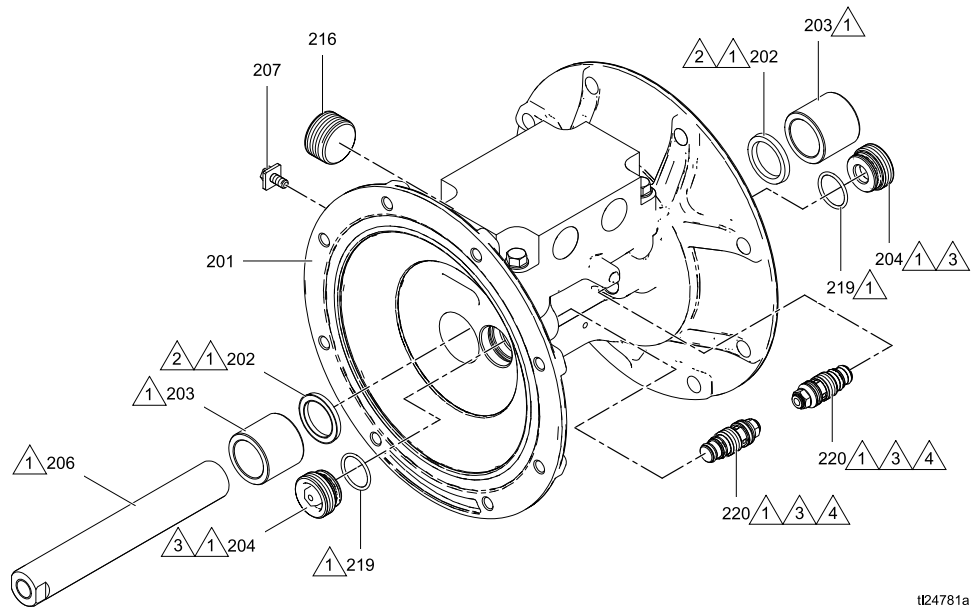

Secondary Air Module

t24781a



Apply lithium based grease.



Lips must face out of housing.



Cartridges (204) must be installed before pilot valves (205) or secondary pilot plugs (220).



Torque to 20-25 in.-lb (2-3 N•m).

Reassemble the Fluid Diaphragms

Follow all notes in the illustrations. These notes contain **important** information.

NOTE: Apply lithium-based grease whenever instructed to grease.

1. Assemble the center diaphragm section:
 - a. Assemble the primary side air plate (105*), the center diaphragm (109*), and the secondary side air plate (103*) on the set screw (104*).

- b. **IMPORTANT:** The marked “Air” side of the center diaphragm **must** face the primary air side plate and the primary air module.
- c. Install a shaft (206*) on each end.
- d. Tighten until assembly is fully seated and parts do not freely rotate.

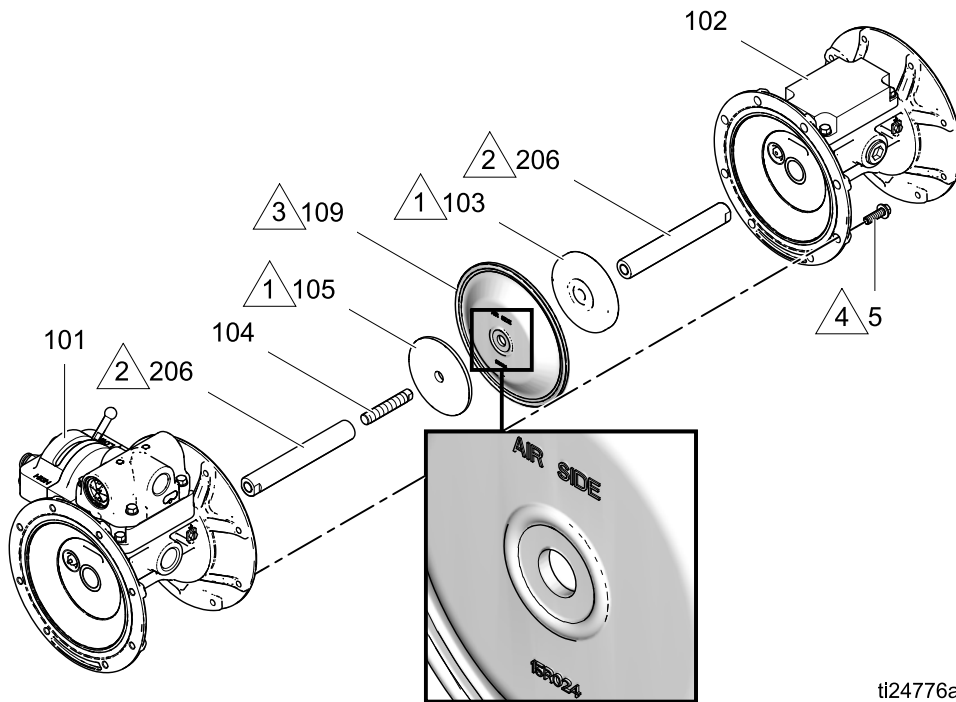

ti24776a



Rounded side faces diaphragm.



Apply lithium based grease.



AIR SIDE markings on center diaphragm must face the primary air module.



Torque to 100 in-lb (11.3 N•m).



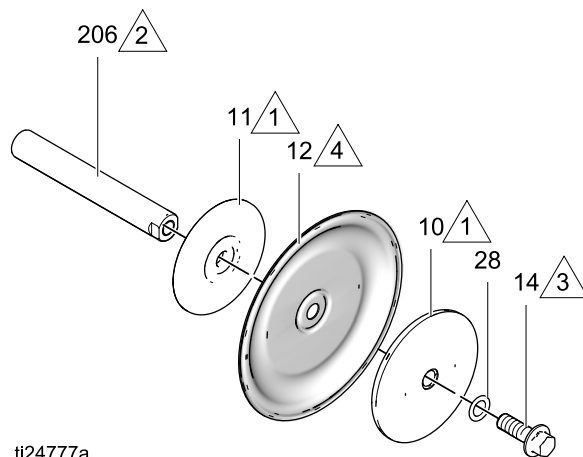

2. Grease the shaft u-cups (202*) and the length of both diaphragm shafts (206*). Slide the shaft on the primary side (closest to air plate 105*) into the primary air module.
3. Slide the secondary air module onto the secondary side shaft (closest to air plate 103*).
4. Install the diaphragm joint bolts (5). Torque to 100 in-lb (11.3 N•m). Follow [Torque Instructions, page 24](#).
5. **Bolt-Through Diaphragms**
 - a. Assemble the o-ring (28), the fluid side diaphragm plate (10), the diaphragm (12), and the air side diaphragm plate (11), on a diaphragm shaft bolt (14), exactly as shown.
 - b. Apply medium-strength (blue) thread locker to the threads of the bolt (14). Screw the assembly into the shaft of the secondary air module hand-tight.
 - c. Repeat for the other diaphragm assembly and install on the primary air module.
 - d. Torque both bolts to 20–25 ft-lb (27–34 N•m) at 100 rpm maximum. Do not over-torque.

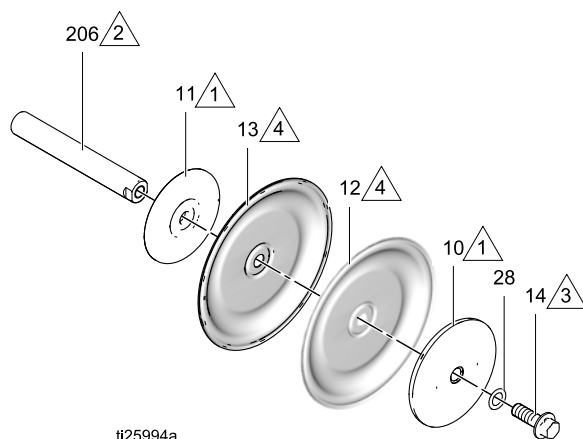

ti24777a







ti25994a

-  Rounded side faces diaphragm.
-  Apply lithium based grease.
-  Apply primer and medium-strength (blue) thread locker. Torque to 20–25 ft-lb (27–34 N•m) at 100 rpm maximum.
-  AIR SIDE markings on fluid diaphragms must face center housing.

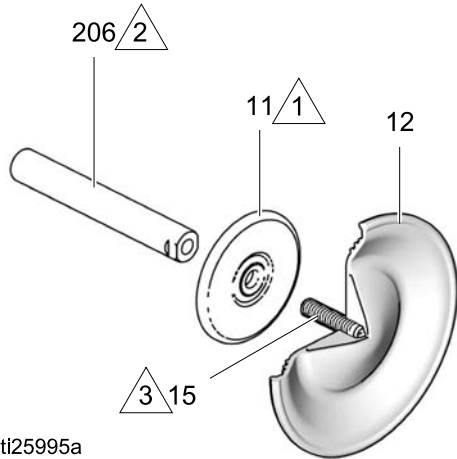
6. Overmolded Diaphragms

- a. If the diaphragm setscrew comes loose or is replaced, apply permanent (red) thread sealant to the diaphragm-side threads. Screw into the diaphragm until tight.
- b. Assemble the air side plate onto the diaphragm. The rounded side of the plate must face the diaphragm.



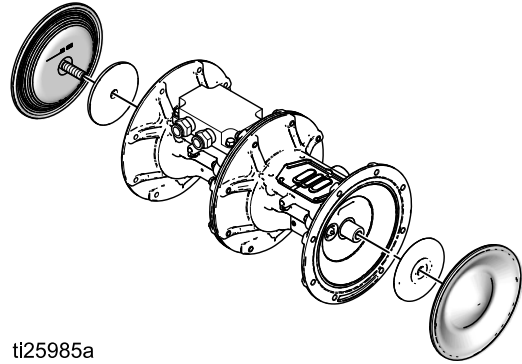

-  Rounded side faces diaphragm.
-  Apply lithium based grease.
-  If screw comes loose or is replaced, apply permanent (red) thread locker to the diaphragm side threads. Apply primer and medium-strength (blue) thread locker to the shaft side threads.

- c. Apply medium-strength (blue) thread locker to the threads of the diaphragm assembly. Screw the assembly into the shaft of the secondary air module as tight as possible by hand.
- d. Repeat for the other diaphragm assembly and install it on the primary air module.



7. Reattach the secondary side fluid cover (2). The arrow must point toward the air valve. See [Torque Instructions, page 24](#).

				
To avoid injury, keep your fingers away from the moving diaphragms when air pressure is applied.				

8. To ensure proper seating and extend diaphragm life, apply air pressure to the pump prior to attaching the fluid cover on the primary air module.

NOTE: Be sure the High/Low valve is attached. See [Replace Complete High/Low Valve, page 14](#).

- a. Place the supplied tool on top of the air valve gasket (213). Arrows (A) must face toward the fluid cover that is already attached.

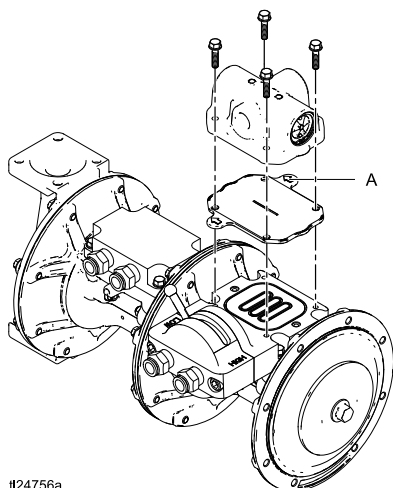

tt24756a

Figure 3 Diaphragm Install Tool

- b. Reattach the air valve.
 - c. Supply a minimum of 10 to 20 psi (0.07–0.14 MPa, 0.7–1.4 bar) air pressure to the air valve. Shop air may be used. The diaphragm will shift so the second fluid cover will seat properly. Keep air pressure on until the second fluid cover is attached.
 - d. Attach the second fluid cover (2). See [Torque Instructions, page 24](#).
 - e. Remove the air valve and the tool. Verify that the gasket (213), is in place, and reattach the air valve. See [Torque Instructions, page 24](#).
- NOTE:** These steps must be followed anytime the fluid covers are removed.
- f. Reassemble the ball check valves and manifolds as explained in [Check Valve Repair, page 16](#).
 - g. If not already attached, reinstall the air lines and the muffler.

Torque Instructions

NOTE: All fasteners for the fluid covers, center diaphragm joint, and manifolds have a thread-locking adhesive patch applied to the threads. If this patch is excessively worn, the fasteners may loosen during operation. Replace screws with new ones or apply medium-strength (blue) Loctite or equivalent to the threads.

If fluid cover, center diaphragm joint, or manifold fasteners have been loosened, it is important to torque them using the following procedure to improve sealing.

NOTE: Always completely torque the fluid covers and the center diaphragm joint before torquing manifolds.

Start all fluid cover or center diaphragm joint screws a few turns. Then turn down each screw just until head contacts cover. Then turn each screw by 1/2 turn or less working in a crisscross pattern to specified torque. Repeat for manifolds.

Fluid cover, center diaphragm joint, and manifold fasteners: 100 in-lb (11.3 N•m)

Lubricate air valve fasteners prior to reassembly to prevent galling. Retorque the air valve fasteners (V) in a crisscross pattern to specified torque.

Air valve fasteners: 80 in-lb (9.0 N•m)

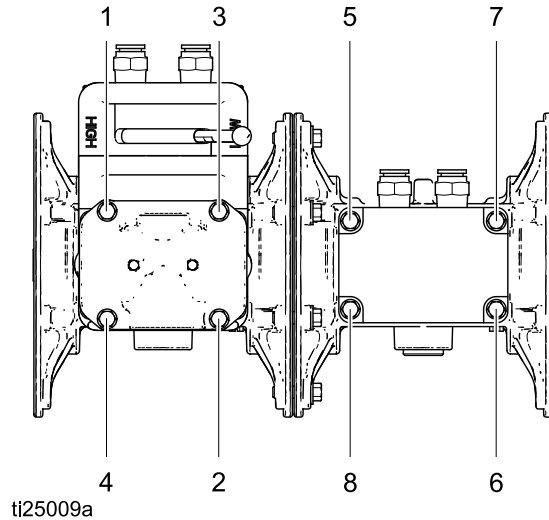

ti25009a

Air Valve Fasteners

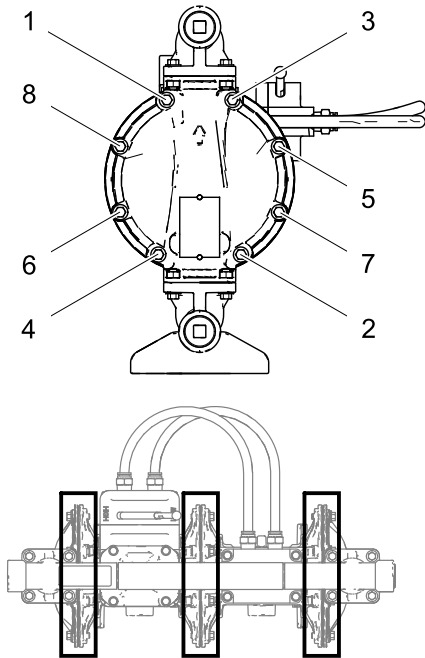

ti23671a

Fluid Covers and Center Diaphragm Joint

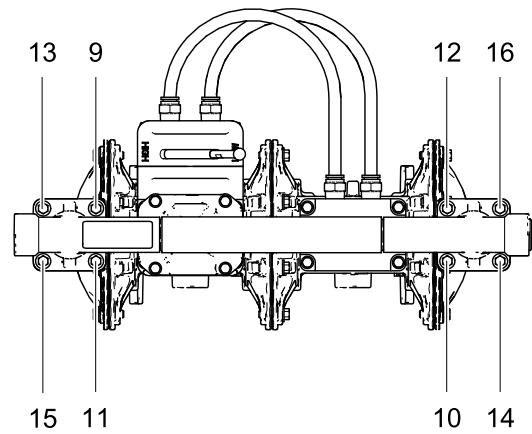

ti23672a

Manifolds

Parts

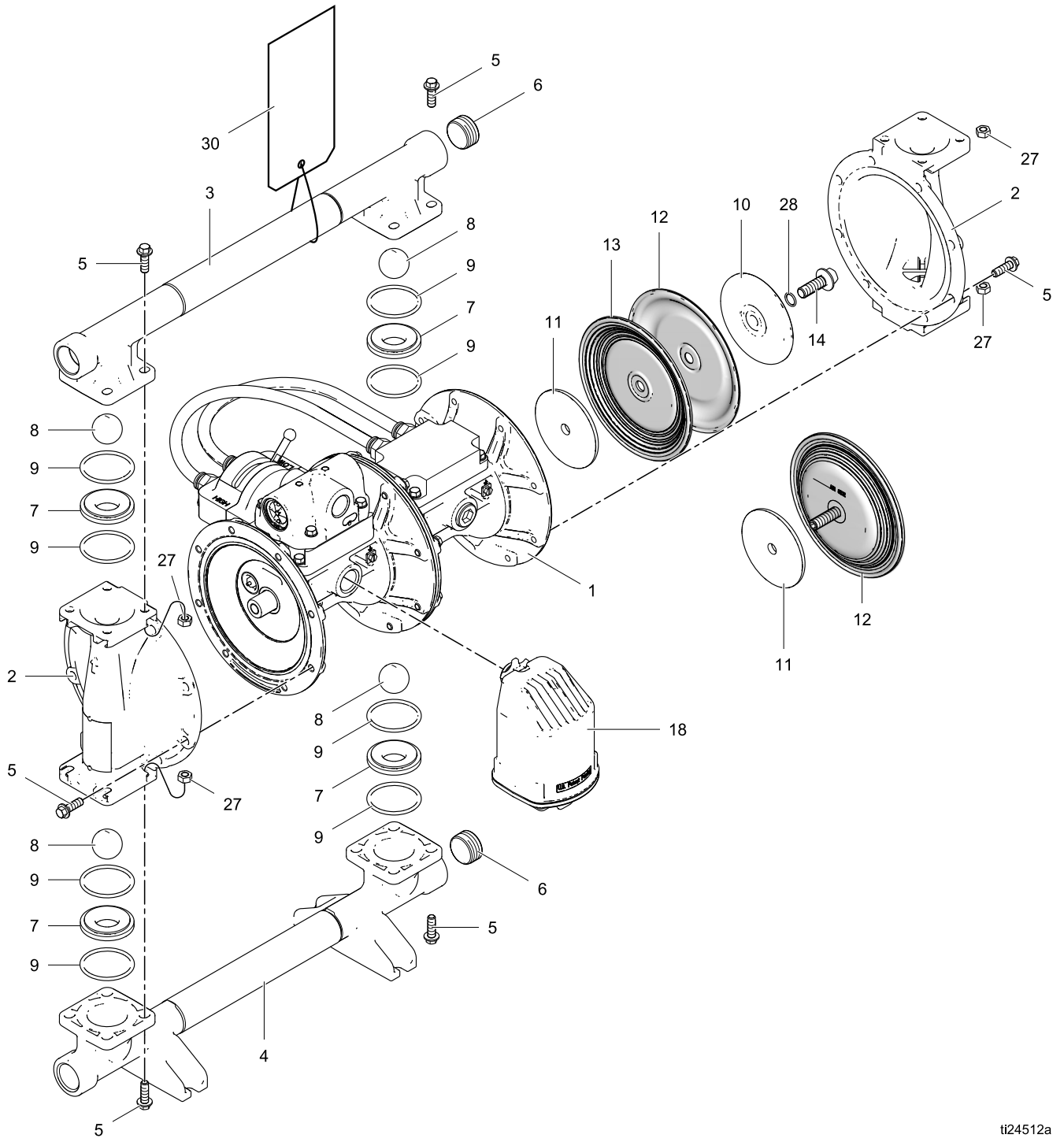

ti24512a

Parts/Kits Quick Reference

Use this table as a quick reference for parts/kits. Go to the pages indicated in the table for a full description of kit contents.

Ref.	Part/Kit	Description	Qty.
1	— — —	CENTER SECTION; Aluminum, not sold separately. <i>See page 28.</i>	1
2	24X053	COVER, fluid, kit; stainless steel, <i>see page 40</i>	2
3	24W833 24W834 24W837 24W838	MANIFOLD, outlet, kit; <i>see page 40</i> Aluminum, npt Aluminum, bspt Stainless steel, npt Stainless steel, bspt	1
4	24W835 24W836 24W839 24W840	MANIFOLD, inlet, kit; <i>see page 40</i> Aluminum, npt Aluminum, bspt Stainless steel, npt Stainless steel, bspt	1
5	24X051 24C064 24B654	FASTENERS, <i>see page 40</i> BOLT, M8 x 1.25 x 25 mm, for aluminum manifolds, includes nuts, 8-pack BOLT, M8 x 1.25 x 20 mm, for stainless steel manifolds, includes nuts, 8-pack BOLT, M8 x 1.25 x 25 mm, for fluid covers and bolting center sections together, 8-pack	2 2 3
6	24C617 24C618	PLUG, Manifold, Kit; used only on aluminum manifolds; 6-pack For npt manifolds For bsp manifolds	1
7	24B633 24B636 24B637	SEATS 4-pack, includes 8 o-rings, <i>see page 41</i> Geolast Santoprene Stainless steel	1

▲ Replacement Warning labels, signs, tags, and cards are available at no cost.

Ref.	Part/Kit	Description	Qty.
8	24B641 24B644 24B646 24B647	BALLS, valve, check; 4-pack; Includes 8 o-rings, <i>see page 41</i> Geolast Polychloroprene with SST core Santoprene Stainless Steel	1
9	24B655	O-RING, seat; 8-pack, <i>see page 44</i>	1
10	— — —	PLATE, fluid side diaphragm; included in Air and Fluid Plate Kit 24C035, <i>see page 43</i>	2
11	— — —	PLATE, air side diaphragm ; included in Air and Fluid Plate Kit 24C035; <i>see page 43</i>	2
12	24B622 24B625 24F926 24B628	DIAPHRAGM, kit; 2-pack <i>see page 42</i> Buna-N Bolt-Through Polychloroprene Overmolded PTFE/Santoprene Two Piece Bolt Through Santoprene	1
13	— — —	DIAPHRAGM, backup, Santoprene, included in Kit 24F926	2
14	24C099	BOLT, M12–1.75 x 35 mm, <i>for bolt-through diaphragms, includes o-ring, ref 28</i>	2
18	24D642	MUFFLER, kit; includes o-ring and mounting hardware	1
19	188621▲	LABEL, warning	1
27	— — —	NUT, included with Ref. 5, 8-pack	2
28	— — —	O-RING, included in diaphragm kits	2
30	17C772▲	TAG, warning, torque instructions	1
35	198382▲	LABEL, warning, multilingual	1

— — — These parts are not sold separately.

Center Section

Sample Configuration Number

Pump Model	Center Section and Air Valve	Fluid Covers and Manifolds	Seats	Balls	Diaphragms	Seat and Manifold Seal
1050HP	A01A	A1	SS	SP	SP	PT

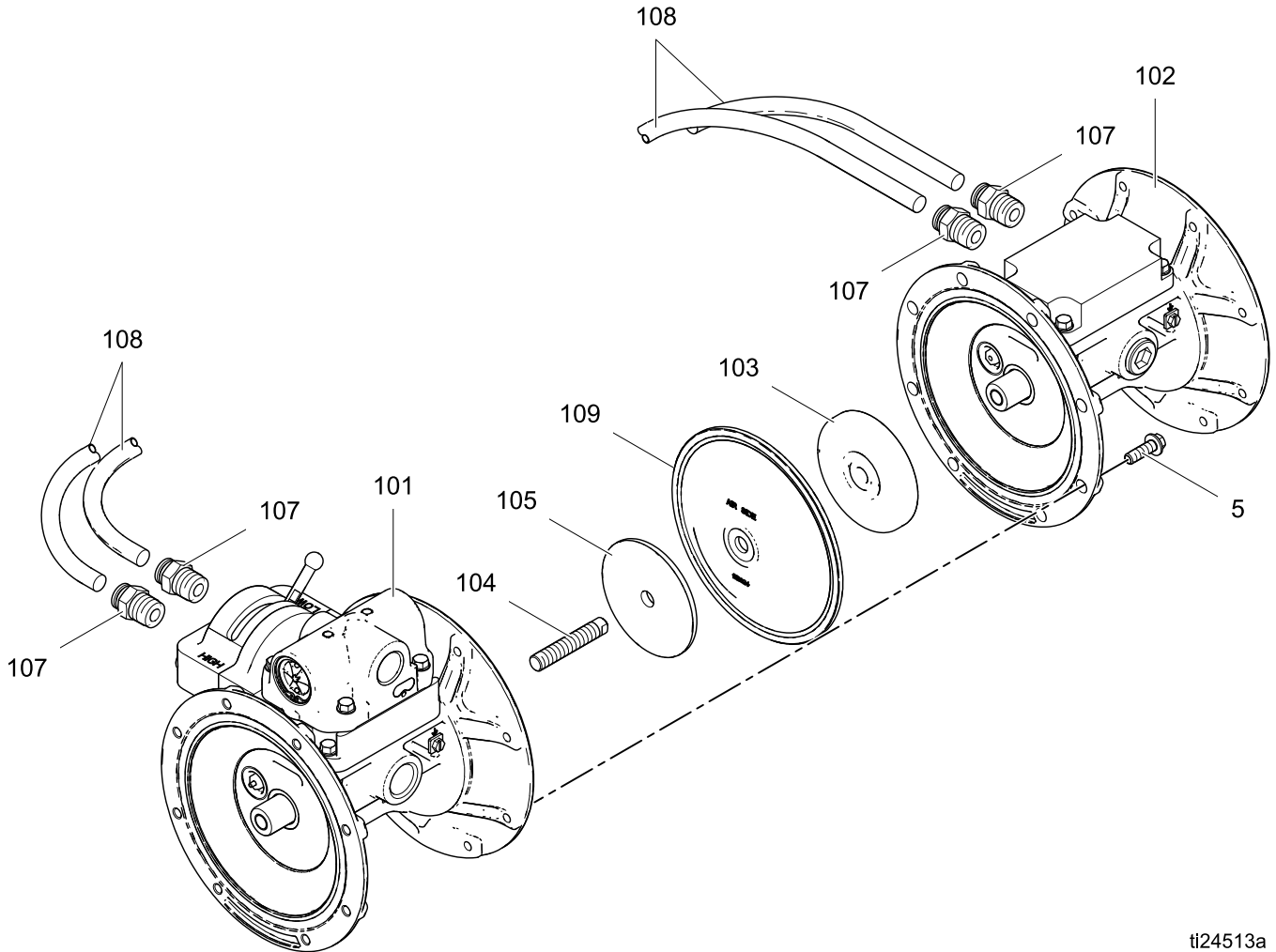

ti24513a

Ref	Description	Qty	Ref	Description	Qty
101	AIR MODULE, primary, <i>see page 26</i>	1	107	FITTING, air, 1/2 npt x 1/2 T, <i>see page 30</i>	4
102	AIR MODULE, secondary, <i>see page 28</i>	1	108	HOSE, air; 15 in. segment, <i>see page 30</i>	2
103*	PLATE, air, secondary side	1	109*	DIAPHRAGM, Santoprene	1
104*	SCREW, set, M12	1	* Parts included in Center Section Rebuild Kit. <i>See page 30.</i>		
105*	PLATE, air, primary side	1			

Primary Air Module

Sample Configuration Number

Pump Model	Center Section and Air Valve	Fluid Covers and Manifolds	Seats	Balls	Diaphragms	Seat and Manifold Seal
1050HP	A01A	A1	SS	SP	SP	PT

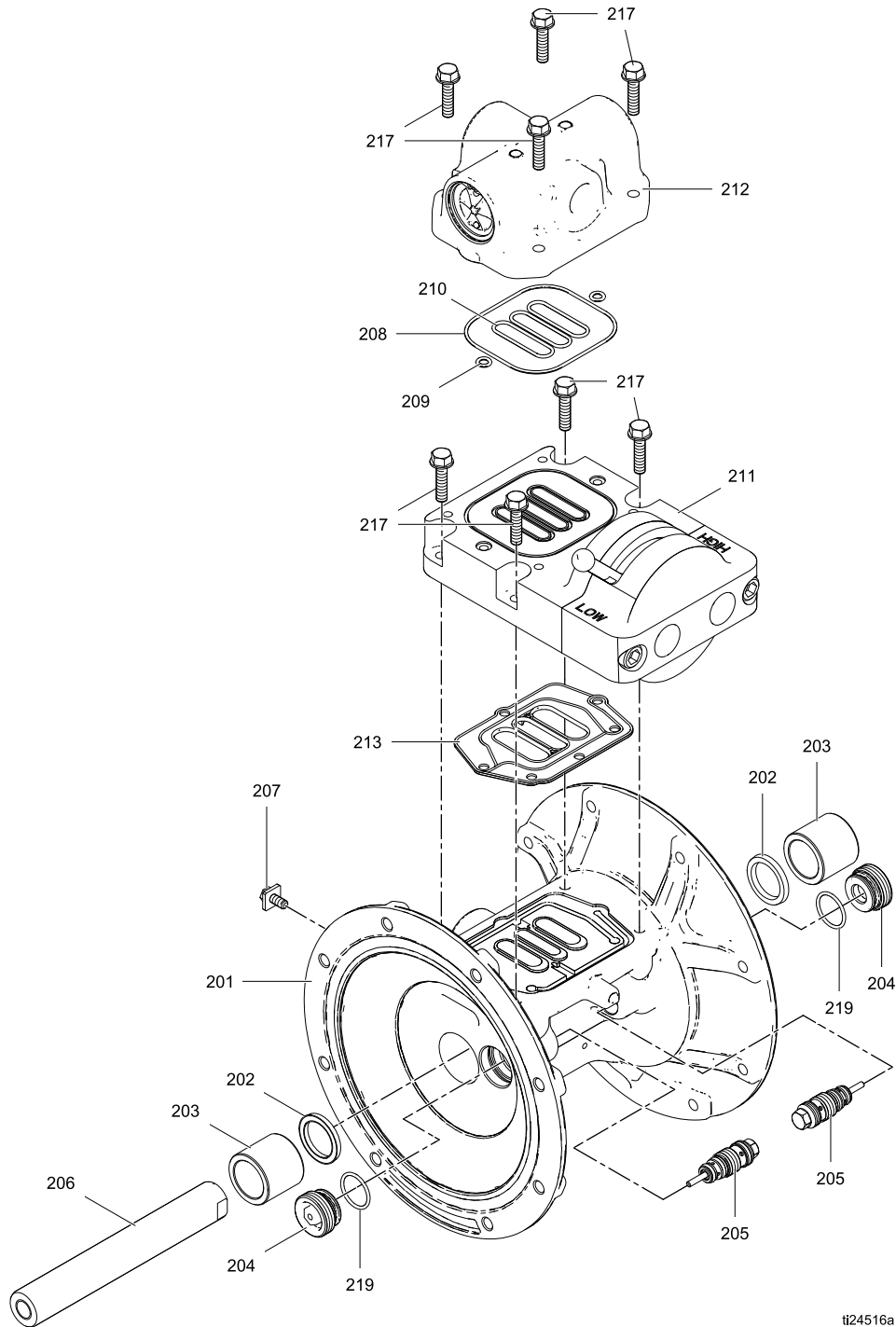

ti24516a

Ref	Description	Qty	Ref	Description	Qty
201	HOUSING, center, not sold separately	1	210	O-RING, Buna-N, 1.125 in. (29 mm) OD, <i>see page 31</i>	3
202*	U-CUP, center shaft	2	211	VALVE, High/Low, <i>see page 35</i>	1
203*	BEARING, center shaft	2	212	VALVE, air, <i>see page 32</i>	1
204*	CARTRIDGE, pilot receiver	2	213*	GASKET, air valve	1
205*	VALVE, pilot	2	217*	SCREW, M6 x 25, thread forming	8
206*	SHAFT, center	1	219*	O-RING, receiver cartridge, Buna-N, 0.9 in. (23 mm) OD	2
207	SCREW, ground, Order PN 116343	1	<i>* Parts included in Center Section Rebuild Kit. See page 30.</i>		
208	O-RING, Buna-N, 3.2 in. (81 mm) OD, <i>see page 31</i>	1			
209	O-RING, Buna-N, 0.35in. (9 mm) OD, <i>see page 31</i>	2			

Secondary Air Module

Sample Configuration Number

Pump Model	Center Section and Air Valve	Fluid Covers and Manifolds	Seats	Balls	Diaphragms	Seat and Manifold Seal
1050HP	A01A	A1	SS	SP	SP	PT

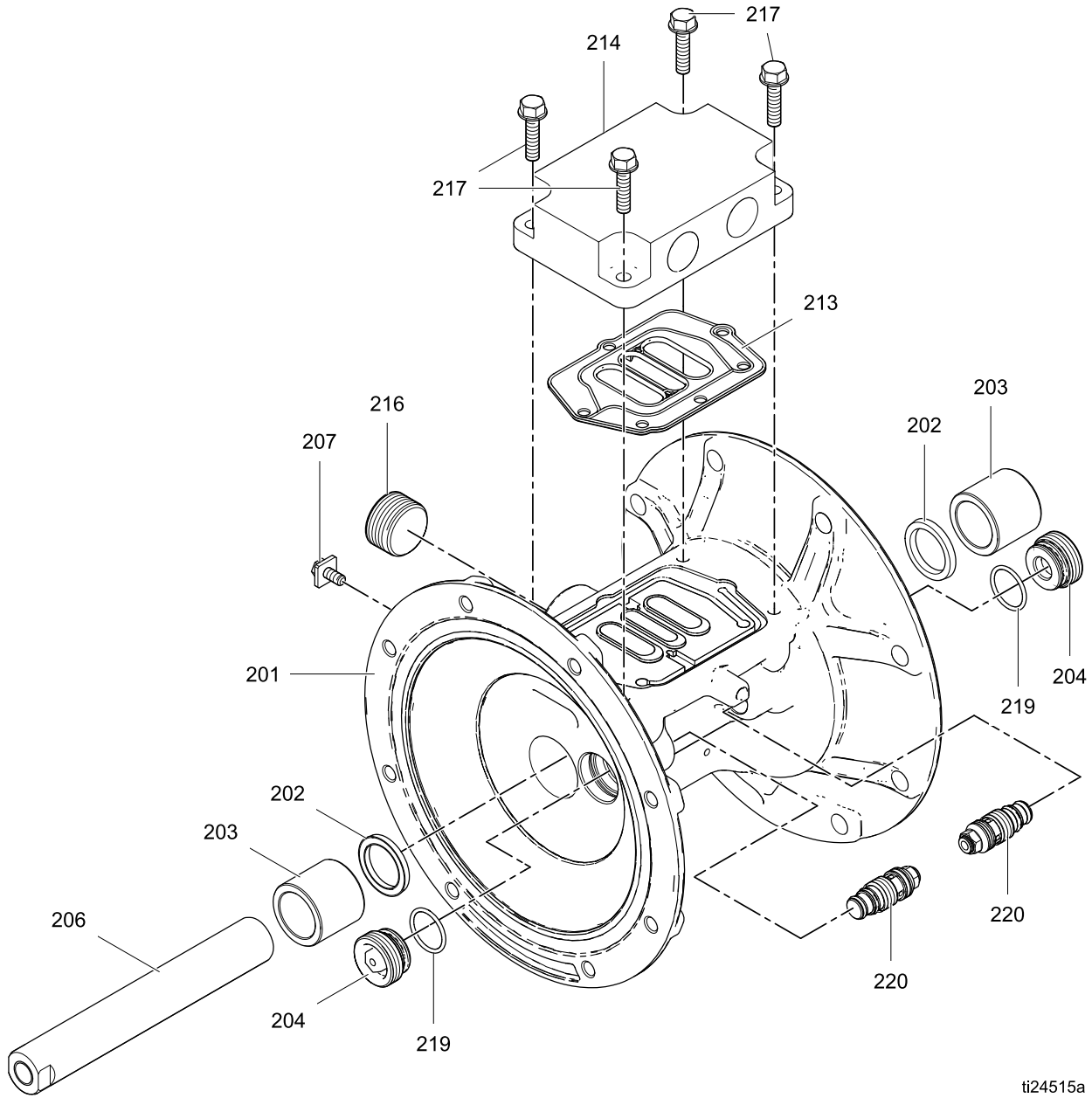

ti24515a

Ref	Description	Qty	Ref	Description	Qty
201	HOUSING, center, not sold separately	1	213*	GASKET, air valve	1
202*	U-CUP, center shaft	2	216	PLUG, pipe, order PN 102726	1
203*	BEARING, center shaft	2	217*	SCREW, M6 x 25, thread forming	4
204*	CARTRIDGE, pilot receiver	2	219*	O-RING, receiver cartridge, Buna-N, 0.9 in. (23 mm) OD	2
206*	SHAFT, center	1	220*	PLUG, secondary pilot	2
207	SCREW, ground, order PN 116343	1	* <i>Parts included in Center Section Rebuild Kit. See page 30.</i>		
214	PLATE, adapter, <i>see page 31</i>	1			

Center Section Kits

Sample Configuration Number

Pump Model	Center Section and Air Valve	Fluid Covers and Manifolds	Seats	Balls	Diaphragms	Seat and Manifold Seal
1050HP	A01A	A1	SS	SP	SP	PT

Center Section Rebuild Kit 24W946

Kit includes:

- 2 center shaft (206)
- 4 center shaft bearings (203)
- 4 center shaft u-cups (202)
- 2 air valve gasket (213)
- 8 screws (217)
- 8 seat o-rings (9)
- 2 pilot valves (205)
- 2 secondary pilot plugs (220)
- 4 pilot valve receiver cartridges (204)
- 4 receiver cartridge o-rings (219)
- 1 grease packet
- 1 air plate, secondary side (103)
- 1 air plate, primary side (105)
- 1 set screw, M12 (104)
- 1 diaphragm, Santoprene (109)

Hose and Fitting Kit 24W947

Kit includes:

- 4 air fittings (107)
- 2 air hoses (108)

Center Diaphragm Kit 24W953

Kit includes:

- 1 air plate, secondary side (103)
- 1 air plate, primary side (105)
- 1 set screw, M12 (104)
- 1 diaphragm, Santoprene (109)

Pilot Valve Assembly Kit 24B657

Kit includes:

- 2 pilot valve assemblies (205)
- 2 receiver cartridges (204)
- 2 receiver cartridge o-rings (219)
- 1 grease packet

Secondary Pilot Plug Assembly Kit 24X057

Kit includes:

- 2 secondary pilot plug assemblies (220)
- 2 receiver cartridges (204)
- 2 receiver cartridge o-rings (219)
- 1 grease packet

Center Shaft Kit 24B656

NOTE: Purchase 2 kits if you are rebuilding both the primary and secondary air modules.

Kits include:

- 2 center shaft u-cups (202)
- 1 center shaft (206)
- 2 center shaft bearings (203)
- 1 grease packet

Center Shaft Bearing Kit 24B658

NOTE: Purchase 2 kits if you are rebuilding both the primary and secondary air modules.

Kit includes:

- 2 center shaft u-cups (202)
- 2 center shaft bearings (203)
- 1 grease packet

High/Low Manifold Seals Kit 24W952

Kit includes:

- 1 o-ring (208)
- 2 o-rings (209)
- 3 o-rings (210)
- 1 air valve gasket (213)

Adapter Plate Kit 24W951

Kit includes:

- 1 adapter plate (214)
- 4 screws (217)
- 1 air valve gasket (213)

Air Valve

Sample Configuration Number

Pump Model	Center Section and Air Valve	Fluid Covers and Manifolds	Seats	Balls	Diaphragms	Seat and Manifold Seal
1050HP	A01A	A1	SS	SP	SP	PT

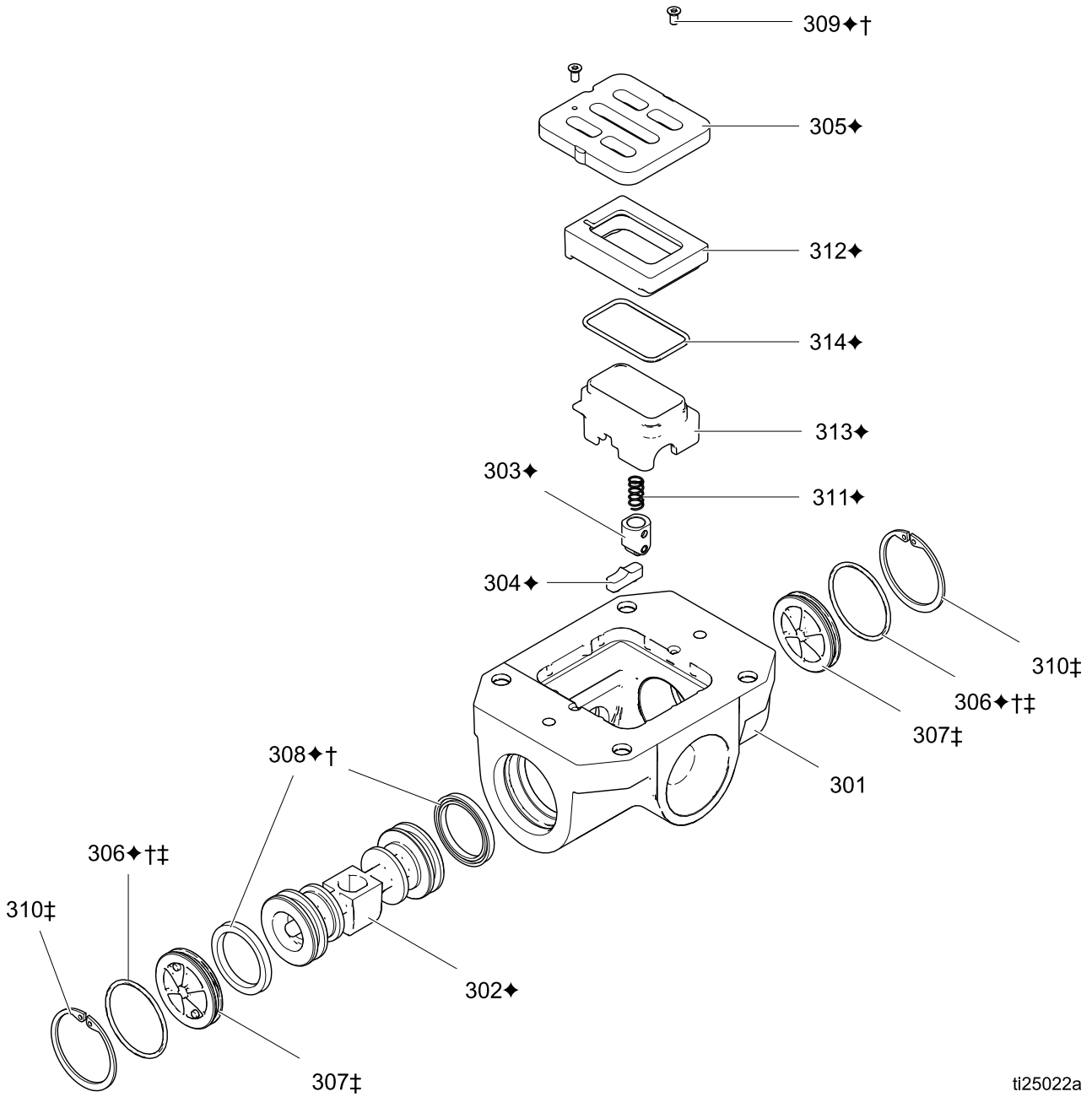

ti25022a

Ref	Description	Qty	Ref	Description	Qty
301	HOUSING, not sold separately	1	308◆†	U-CUP, carboxylated nitrile	2
302◆	PISTON	1	309◆†	SCREW, M3, thread forming	2
303◆	PISTON ASSEMBLY, detent	1	310‡	RETAINING RING	2
304◆	CAM, detent	1	311◆	SPRING, detent	1
305◆	PLATE, air valve	1	312◆	BASE, cup	1
306◆†‡	O-RING	2	313◆	CUP	1
307‡	CAP, end	2	314◆	O-RING, cup	1

◆ *Parts included in Air Valve Repair Kit.*

‡ *Parts included in Air Valve End Cap Kit.*

† *Parts included in Air Valve Seals Kit..*

Sample Configuration Number

Pump Model	Center Section and Air Valve	Fluid Covers and Manifolds	Seats	Balls	Diaphragms	Seat and Manifold Seal
1050HP	A01A	A1	SS	SP	SP	PT

† Air Valve Seals Kit 24K859

Kit includes:

- 2 end cap o-rings (306)
- 2 piston u-cups (308)
- 2 screws, M3, shorter (309)
- 2 screws, #4, longer (not used)
- 1 air valve gasket (213)
- 1 grease packet
- 1 solenoid release button o-ring (not shown, not used)

◆ Air Valve Repair Kit 24K860

Kit includes:

- 1 air valve piston (302)
- 1 detent piston assembly (303)
- 1 detent cam (304)
- 1 air valve plate (305)
- 2 end cap o-rings (306)
- 2 piston u-cups (308)
- 2 screws, M3, shorter (309)
- 2 screws, #4, longer (not used)
- 1 detent spring (311)
- 1 air cup base (312)
- 1 air cup (313)
- 1 air cup o-ring (314)
- 1 solenoid release button o-ring (not shown, not used)
- 1 air valve gasket (213)
- 1 grease packet

Air Valve Replacement Kit 24W897

Kit includes:

- 1 air valve assembly (212)
- 1 o-ring (208)
- 2 o-rings (209)
- 3 o-rings (210)
- 4 screws (217)

‡ Air Valve End Cap Kit 24A361

Kit includes:

- 2 end caps (307)
- 2 retaining rings (310)
- 2 o-rings (306)

High/Low Valve

Sample Configuration Number

Pump Model	Center Section and Air Valve	Fluid Covers and Manifolds	Seats	Balls	Diaphragms	Seat and Manifold Seal
1050HP	A01A	A1	SS	SP	SP	PT

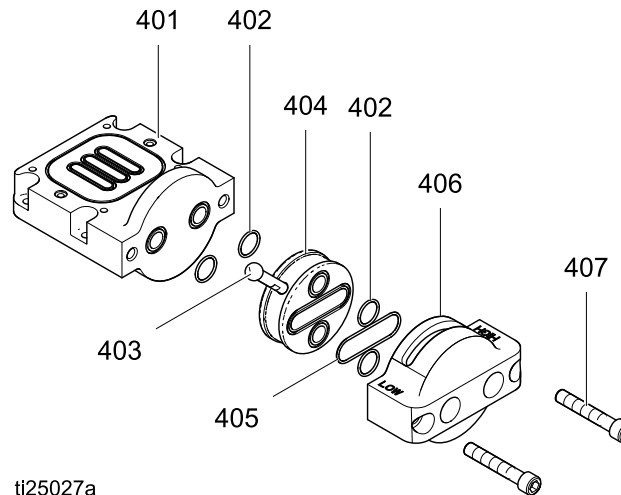

Ref	Description	Qty	Ref	Description	Qty
401	PLATE, adapter, not sold separately	1	406	CAP, adapter plate, not sold separately	1
402	O-RING, PTFE, 0.8 in. (20 mm) OD	4	407	SCREW, cap, socket head, 3/8-16 x 2.25; order PN 114666	2
403	LEVER, HIGH-LOW shift	1			
404	SPOOL	1			
405	O-RING, PTFE, 1.9 in. (48 mm) OD	1			

High/Low Valve Replacement Kit 24W948

Kit includes:

- 1 High/Low valve assembly (211)
- 1 air valve gasket (213)
- 4 screws (217)
- 1 grease packet

High/Low Valve Spool Kit 24W950

Kit includes:

- 1 Spool (404)
- 4 o-rings (402)
- 1 o-ring (405)
- 1 lever (403)
- 1 grease packet

High/Low Valve Seals Kit 24W949

Kit includes:

- 4 o-rings (402)
- 1 o-ring (405)
- 1 grease packet

Fluid Covers and Manifolds

Sample Configuration Number

Pump Model	Center Section and Air Valve	Fluid Covers and Manifolds	Seats	Balls	Diaphragms	Seat and Manifold Seal
1050HP	A01A	A1	SS	SP	SP	PT

Fluid Cover Kit 24X053

Kit includes:

- 1 fluid cover (2)
- 4 o-rings (9), PTFE

Aluminum Outlet Manifold Kits

A1 (npt)	24W833
A2 (bsp)	24W834

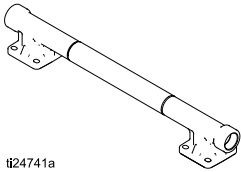

Kits include:

- 1 outlet manifold (3)
- 1 pipe plug (6)
- 4 o-rings(9), PTFE
- 1 warning label

Aluminum Inlet Manifold Kits	
A1 (npt)	24W835
A2 (bsp)	24W836

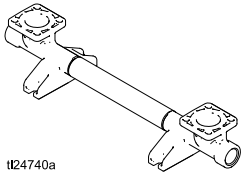

Kits include:

- 1 inlet manifold (4)
- 1 pipe plug (6)
- 4 o-rings (9), PTFE

Stainless Steel Outlet Manifold Kits	
S1 (npt)	24W837
S2 (bsp)	24W838

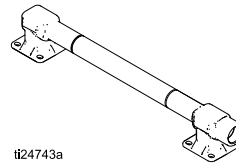

Kits include:

- 1 outlet manifold (3)
- 4 o-rings (9), PTFE
- 1 warning label

Stainless Steel Inlet Manifold Kits	
S1 (npt)	24W839
S2 (bsp)	24W840

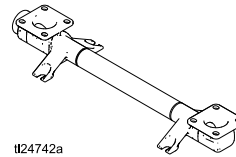

Kits include:

- 1 inlet manifold (4)
- 4 o-rings (9), PTFE

Fastener Kits	
A1, A2	24X051
S1, S2	24C064
All Models	Order Kit 24B654 for fluid covers and bolting the two air modules together, includes 8 bolts

Kits include:

- 8 screws, (5)
- 8 nuts (27, Kits 24X051 and 24C064)

Seats and Check Balls

Sample Configuration Number

Pump Model	Center Section and Air Valve	Fluid Covers and Manifolds	Seats	Balls	Diaphragms	Seat and Manifold Seal
1050HP	A01A	A1	SS	SP	SP	PT

Seat Kits	
GE	24B633
SP	24B636
SS	24B637

Kit includes:

- 4 seats (7), material indicated in table
- 8 o-rings, PTFE (9)

Ball Kits	
CW	24B644
GE	24B641
SP	24B646
SS	24B647

Kit includes:

- 4 balls (8), material indicated in table
- 8 o-rings, PTFE (9)

Diaphragms

Sample Configuration Number

Pump Model	Center Section and Air Valve	Fluid Covers and Manifolds	Seats	Balls	Diaphragms	Seat and Manifold Seal
1050HP	A01A	A1	SS	SP	SP	PT

1-Piece Bolt-Through Diaphragm Kits	
BN	24B622
SP	24B628

Kits include:

- 8 o-rings, PTFE (9)
- 2 diaphragms (12), material indicated in table
- 2 o-rings for the bolt (28)
- 1 diaphragm install tool
- 1 packet anaerobic adhesive

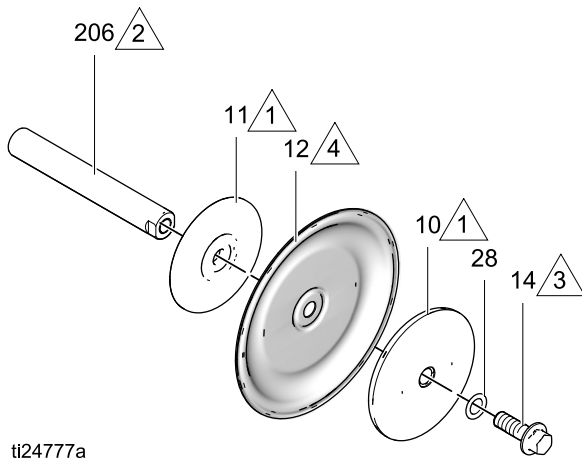

2-Piece Bolt-Through Diaphragm Kits	
PT	24F926

Kit includes:

- 8 o-rings (9), PTFE
- 2 diaphragms (12), PTFE
- 2 backup diaphragms (13)
- 2 o-rings (28) for the bolt
- 1 diaphragm install tool
- 1 packet anaerobic adhesive

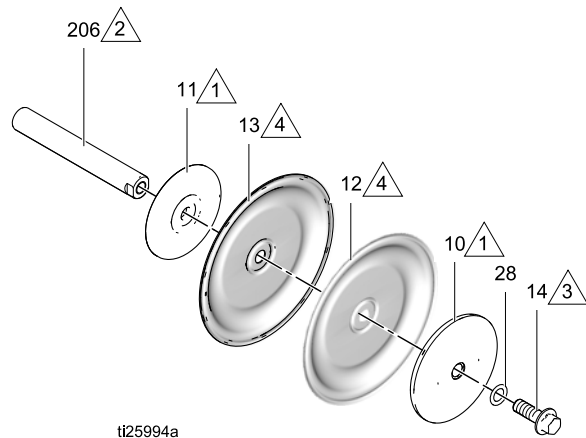

Overmolded Diaphragm Kits	
CO	24B625

Kit includes:

- 8 o-rings (9), PTFE
- 2 overmolded diaphragms (12), polychloroprene
- 2 diaphragm set screws (15), stainless steel
- 1 diaphragm install tool
- 1 packet anaerobic adhesive

Air and Fluid Plate Kit 24C035

Kit includes:

- 1 air side diaphragm plate (11)
- 1 fluid side diaphragm plate (10)
- 1 o-ring (28)
- 1 bolt (14)

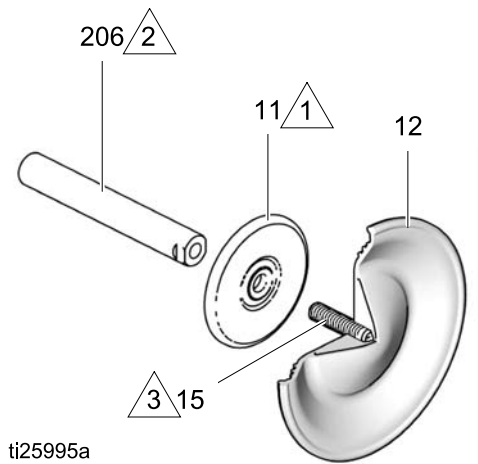

Manifold Seals

Sample Configuration Number

Pump Model	Center Section and Air Valve	Fluid Covers and Manifolds	Seats	Balls	Diaphragms	Seat and Manifold Seal
1050HP	P01A	P1	SS	SP	SP	PT

Manifold O-Ring Kits	
All Models	24W212

Kits include:

- 8 o-rings (9), PTFE

Technical Data

	US	Metric
Maximum fluid working pressure	250 psi	1.72 MPa, 17.2 bar
Air pressure operating range	20-125 psi	0.14-0.86 MPa, 1.4-8.6 bar
Fluid displacement per cycle		
Low Pressure Setting	0.17 g	0.64 l
High Pressure Setting	0.20 g	0.76 l
Air consumption	at 70 psi, 20 gpm	at 4.8 bar, 76 lpm
Low Pressure Setting	26 scfm	0.7 cubic meters per minute
High Pressure Setting	51 scfm	1.4 cubic meters per minute
Maximum values with water as media under submerged inlet conditions at ambient temperature:		
Maximum air consumption		
Low Pressure Setting	59 scfm	1.7 cubic meters per minute
High Pressure Setting	95 scfm	2.7 cubic meters per minute
Maximum free-flow delivery		
Low Pressure Setting	50 gpm	189 lpm
High Pressure Setting	46 gpm	174 lpm
Maximum pump speed		
Low Pressure Setting	280 cpm	
High Pressure Setting	225 cpm	
Maximum suction lift (varies widely based on ball/seat selection and wear, operating speed, material properties, and other variables)	16 ft dry, 29 ft wet	4.9 m dry 8.8 m wet
Maximum size pumpable solids	1/8 in	3.2 mm
Recommended cycle rate for continuous use	93-140 cpm (in Low or High setting)	
Recommended cycle rate for circulation systems	20 cpm (in Low or High setting)	
Air inlet size	3/4 npt(f)	
Fluid inlet size	1 in. npt(f) or 1 in. bspt	
Fluid outlet size	1 in. npt(f) or 1 in. bspt	
Weight	48 lb (aluminum manifolds) 60 lb (SST manifolds)	21.8 kg (aluminum manifolds) 27.2 kg (SST manifolds)

Sound Power (measured per ISO-9614-2)	
At 70 psi (0.48 MPa, 4.8 bar) and 50 cpm	
Low Pressure Setting	78 dBa
High Pressure Setting	91 dBa
At 100 psi (0.7 MPa, 7.0 bar) and full flow	
Low Pressure Setting	90 dBa
High Pressure Setting	102 dBa
Sound Pressure (tested 3.28 ft [1 m] from equipment)	
At 70 psi (0.48 MPa, 4.8 bar) and 50 cpm	
Low Pressure Setting	84 dBa
High Pressure Setting	96 dBa
At 100 psi (0.7 MPa, 7.0 bar) and full flow	
Low Pressure Setting	84 dBa
High Pressure Setting	96 dBa
Wetted parts	aluminum plus the material(s) chosen for seat, ball, and diaphragm options.
Non-wetted external parts	aluminum, coated carbon steel

Fluid Temperature Range

NOTICE

Temperature limits are based on mechanical stress only. Certain chemicals will further limit the fluid operating temperature range. Stay within the temperature range of the most-restricted wetted component. Operating at a fluid temperature that is too high or too low for the components of your pump may cause equipment damage.

Diaphragm/Ball Material	Fluid Temperature Range	
	Fahrenheit	Celsius
Buna-N (BN)	10° to 180°F	-12° to 82°C
Geolast (GE)	-40° to 150°F	-40° to 66°C
Polychloroprene overmolded diaphragm (NO) or Polychloroprene check balls (NW)	0° to 180°F	-18° to 82°C
2-Piece PTFE/Santoprene Diaphragm (TF)	40° to 180°F	4° to 82°C
Santoprene® (SP)	-40° to 180°F	-40° to 82°C

Graco Standard Husky Pump Warranty

Graco warrants all equipment referenced in this document which is manufactured by Graco and bearing its name to be free from defects in material and workmanship on the date of sale to the original purchaser for use. With the exception of any special, extended, or limited warranty published by Graco, Graco will, for a period of five years from the date of sale, repair or replace any part of the equipment determined by Graco to be defective. This warranty applies only when the equipment is installed, operated and maintained in accordance with Graco's written recommendations.

This warranty does not cover, and Graco shall not be liable for general wear and tear, or any malfunction, damage or wear caused by faulty installation, misapplication, abrasion, corrosion, inadequate or improper maintenance, negligence, accident, tampering, or substitution of non-Graco component parts. Nor shall Graco be liable for malfunction, damage or wear caused by the incompatibility of Graco equipment with structures, accessories, equipment or materials not supplied by Graco, or the improper design, manufacture, installation, operation or maintenance of structures, accessories, equipment or materials not supplied by Graco.

This warranty is conditioned upon the prepaid return of the equipment claimed to be defective to an authorized Graco distributor for verification of the claimed defect. If the claimed defect is verified, Graco will repair or replace free of charge any defective parts. The equipment will be returned to the original purchaser transportation prepaid. If inspection of the equipment does not disclose any defect in material or workmanship, repairs will be made at a reasonable charge, which charges may include the costs of parts, labor, and transportation.

THIS WARRANTY IS EXCLUSIVE, AND IS IN LIEU OF ANY OTHER WARRANTIES, EXPRESS OR IMPLIED, INCLUDING BUT NOT LIMITED TO WARRANTY OF MERCHANTABILITY OR WARRANTY OF FITNESS FOR A PARTICULAR PURPOSE.

Graco's sole obligation and buyer's sole remedy for any breach of warranty shall be as set forth above. The buyer agrees that no other remedy (including, but not limited to, incidental or consequential damages for lost profits, lost sales, injury to person or property, or any other incidental or consequential loss) shall be available. Any action for breach of warranty must be brought within six (6) years of the date of sale..

GRACO MAKES NO WARRANTY, AND DISCLAIMS ALL IMPLIED WARRANTIES OF MERCHANTABILITY AND FITNESS FOR A PARTICULAR PURPOSE, IN CONNECTION WITH ACCESSORIES, EQUIPMENT, MATERIALS OR COMPONENTS SOLD BUT NOT MANUFACTURED BY GRACO. These items sold, but not manufactured by Graco (such as electric motors, switches, hose, etc.), are subject to the warranty, if any, of their manufacturer. Graco will provide purchaser with reasonable assistance in making any claim for breach of these warranties..

In no event will Graco be liable for indirect, incidental, special or consequential damages resulting from Graco supplying equipment hereunder, or the furnishing, performance, or use of any products or other goods sold hereto, whether due to a breach of contract, breach of warranty, the negligence of Graco, or otherwise.

FOR GRACO CANADA CUSTOMERS

The Parties acknowledge that they have required that the present document, as well as all documents, notices and legal proceedings entered into, given or instituted pursuant hereto or relating directly or indirectly hereto, be drawn up in English. Les parties reconnaissent avoir convenu que la rédaction du présente document sera en Anglais, ainsi que tous documents, avis et procédures judiciaires exécutés, donnés ou intentés, à la suite de ou en rapport, directement ou indirectement, avec les procédures concernées.

Graco Information

For the latest information about Graco products, visit www.graco.com.
For patent information, see www.graco.com/patents.

To place an order, contact your Graco Distributor or call to identify the nearest distributor.
Phone: 612-623-6921 or **Toll Free:** 1-800-328-0211 **Fax:** 612-378-3505

All written and visual data contained in this document reflects the latest product information available at the time of publication.

Graco reserves the right to make changes at any time without notice.
Original Instructions. This manual contains English. MM 334390

Graco Headquarters: Minneapolis
International Offices: Belgium, China, Japan, Korea

GRACO INC. AND SUBSIDIARIES • P.O. BOX 1441 • MINNEAPOLIS MN 55440-1441 • USA
Copyright 2014, Graco Inc. All Graco manufacturing locations are registered to ISO 9001.

www.graco.com
Revision B, May 2015