

Instructions, Repair and Parts



Dyna-Star[®]

Hydraulic Reciprocator and High Pressure Pump

3A3005B
EN

High Pressure Pump and Reciprocator used for dispensing grease in wire-line applications for oil well services.

900 psi (6.2 MPa, 62.1 bar) Maximum Hydraulic Input Pressure
10,000 psi (69 MPa, 689 bar) Maximum Fluid Outlet Pressure

Model 25A189: 120 lb Drum Length



Important Safety Instructions



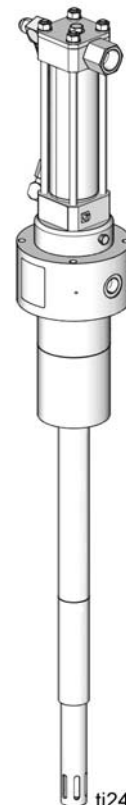

Read all warnings and instructions in this manual.
Save these instructions.



ti24614b

Warnings

The following warnings are for the setup, use, grounding, maintenance, and repair of this equipment. The exclamation point symbol alerts you to a general warning and the hazard symbols refer to procedure-specific risks. When these symbols appear in the body of this manual or on warning labels, refer back to these Warnings. Product-specific hazard symbols and warnings not covered in this section may appear throughout the body of this manual where applicable.

 <h1 style="margin: 0;">WARNING</h1>	
 	<p>SKIN INJECTION HAZARD</p> <p>High-pressure fluid from hose leaks or ruptured components will pierce skin. This may look like just a cut, but it is a serious injury that can result in amputation. Get immediate surgical treatment.</p> <ul style="list-style-type: none"> • Do not put your hand over the fluid outlet. • Do not stop or deflect leaks with your hand, body, glove, or rag. • Follow the Pressure Relief Procedure when you stop dispensing and before cleaning, checking, or servicing equipment. • Tighten all fluid connections before operating the equipment. • Check hoses and couplings daily. Replace worn or damaged parts immediately.
 	<p>FIRE AND EXPLOSION HAZARD</p> <p>When flammable fluids are present in the work area, such as gasoline and windshield wiper fluid, be aware that flammable fumes can ignite or explode. To help prevent fire and explosion:</p> <ul style="list-style-type: none"> • Use equipment only in well ventilated area. • Eliminate all ignition sources, such as cigarettes and portable electric lamps. • Ground all equipment in the work area. • Keep work area free of debris, including rags and spilled or open containers of solvent and gasoline. • Do not plug or unplug power cords or turn lights on or off when flammable fumes are present. • Use only grounded hoses. • Stop operation immediately if static sparking occurs or you feel a shock. Do not use equipment until you identify and correct the problem. • Keep a working fire extinguisher in the work area.



WARNING



EQUIPMENT MISUSE HAZARD

Misuse can cause death or serious injury.

- Do not operate the unit when fatigued or under the influence of drugs or alcohol.
- Do not exceed the maximum working pressure or temperature rating of the lowest rated system component. See **Technical Data** in all equipment manuals.
- Use fluids and solvents that are compatible with equipment wetted parts. See **Technical Data** in all equipment manuals. Read fluid and solvent manufacturer's warnings. For complete information about your material, request Safety Data Sheet (SDS) from distributor or retailer.
- Turn off all equipment and follow the **Pressure Relief Procedure** when equipment is not in use.
- Check equipment daily. Repair or replace worn or damaged parts immediately with genuine manufacturer's replacement parts only.
- Do not alter or modify equipment. Alterations or modifications may void agency approvals and create safety hazards.
- Make sure all equipment is rated and approved for the environment in which you are using it.
- Use equipment only for its intended purpose. Call your distributor for information.
- Route hoses and cables away from traffic areas, sharp edges, moving parts, and hot surfaces.
- Do not kink or over bend hoses or use hoses to pull equipment.
- Keep children and animals away from work area.
- Comply with all applicable safety regulations.



MOVING PARTS HAZARD

Moving parts can pinch, cut or amputate fingers and other body parts.

- Keep clear of moving parts.
- Do not operate equipment with protective guards or covers removed.
- Pressurized equipment can start without warning. Before checking, moving, or servicing equipment, follow the **Pressure Relief Procedure** and disconnect all power sources.



TOXIC FLUID OR FUMES HAZARD

Toxic fluids or fumes can cause serious injury or death if splashed in the eyes or on skin, inhaled, or swallowed.

- Read Safety Data Sheet (SDS) to know the specific hazards of the fluids you are using.
- Store hazardous fluid in approved containers, and dispose of it according to applicable guidelines.



BURN HAZARD

Equipment surfaces and fluid that is heated can become very hot during operation. To avoid severe burns:

- Do not touch hot fluid or equipment.



PERSONAL PROTECTIVE EQUIPMENT

Wear appropriate protective equipment when in the work area to help prevent serious injury, including eye injury, hearing loss, inhalation of toxic fumes, and burns. Protective equipment includes but is not limited to:

- Protective eyewear, and hearing protection.
- Respirators, protective clothing, and gloves as recommended by the fluid and solvent manufacturer.

Installation

Typical Installation

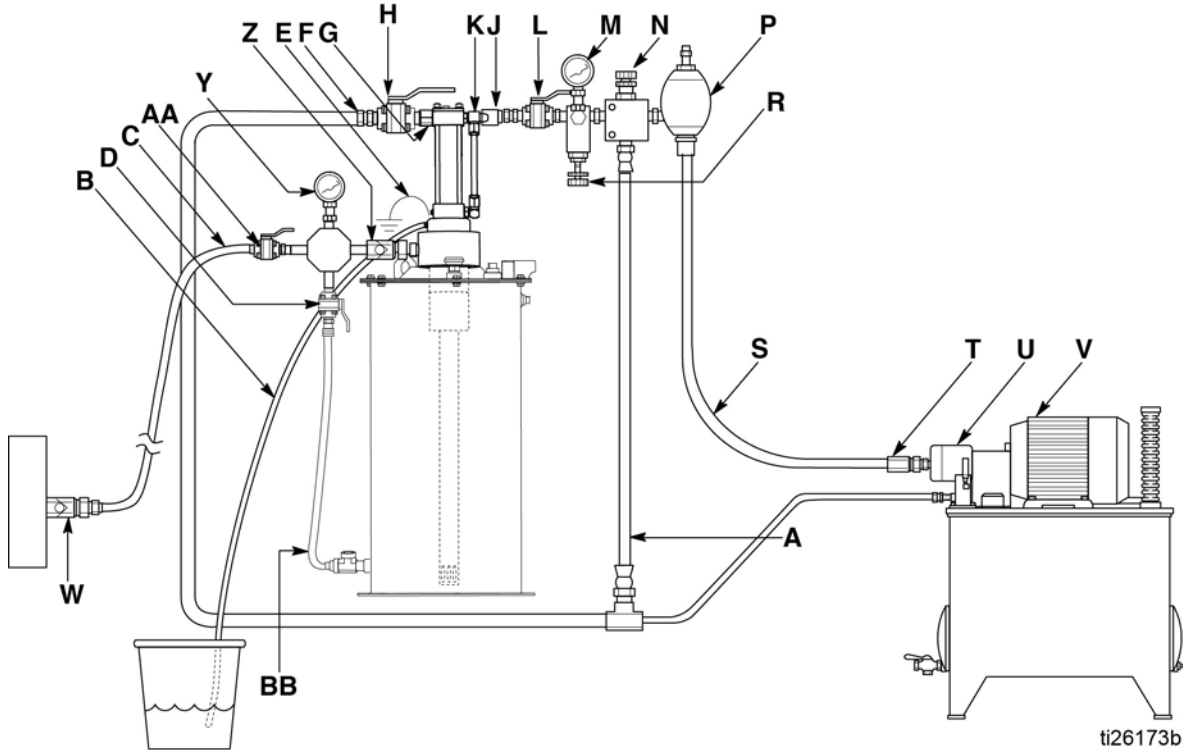

The following Typical Installation is only provided as a guide for selecting and installing system components and accessories. Mount pump to suit the type of installation planned. For assistance in designing a system to suit your needs, contact your Graco Distributor.





Key:

- | | | | |
|---|---|----|--|
| A | Drain line | N | Pressure reducing valve (required in systems over 900 psi [6.2 MPa, 62.1 bar]) |
| B | Weep tube | P | Accumulator |
| C | Fluid outlet line | R | Flow control valve (required in systems over 3 gpm [11 lpm]) |
| D | Drain valve (required) | S | Hydraulic supply line |
| E | Ground wire | T | Check valve |
| F | Hydraulic return line, minimum 3/4 inch I.D. (required) | U | Variable volume pressure compensated pump |
| G | Hydraulic outlet, 3/4" NPT (f) | V | Hydraulic power supply |
| H | Return line shut-off valve, minimum 3/4 inch (required) | W | Check valve |
| J | Hydraulic inlet, 3/4" NPT (m) | Y | Pressure gauge |
| K | Tee, 3/4" NPT | Z | Check valve |
| L | Supply line shut-off valve (required) | AA | Shut-off valve |
| M | Pressure gauge | BB | Drain tube |

Installation Instructions

				
<p>Mount pump securely so it cannot move around during operation. Failure to do so could result in personal injury and/or equipment damage.</p>				



Pump Accessories

				
<p>Maximum Working Pressure of Accessories To reduce the risk of serious injury including fluid injection and splashing in the eyes or on the skin which may be caused if component ruptures, all accessories added to the reciprocator power supply side must have at least 900 psi (6.2 MPa, 62.1 bar) maximum working pressure.</p> <p>All accessories added to the pump fluid outlet side must have at least 10,000 psi (69 MPa, 689 bar) maximum working pressure.</p>				

Pump Outlet Drain Valve (D): helps relieve fluid pressure in pump when pump is shut off. Install valve close to pump fluid outlet.

Hydraulic Power Supply

See Typical Installation, page 4.

				
<p>Limit Fluid Flow to Reciprocator To reduce the risk of overpressurizing the hydraulic reciprocator which could cause a rupture and serious injury, including fluid injection, a hydraulic system must have a means to limit the incoming fluid flow to the reciprocator to a maximum of 3 gpm (11 lpm) and 900 psi (6.2 MPa, 62.1 bar).</p>				

The hydraulic power supply (V) must have a pressure reducing valve and a pressure-compensated flow control.

A flow control valve (R) is required to limit the incoming flow to the reciprocator to a *maximum of 3 gpm (11 lpm)*.

Hydraulic Lines

Shut-off Valves (H, L): installed on the hydraulic supply and return lines. Order Part No. 108537 and 112578.

Drain Line: Monitor the weepage of hydraulic fluid or lubricant. If it seems excessive or increases suddenly, the reciprocator/pump seals may need to be changed.

Hoses: Use a minimum 1/2 inch supply line (S) and minimum 3/4 inch return line (F) on the reciprocator. Contact your Graco representative for details of line sizing.

Pressure Reducing Valve (N): circulates excess hydraulic fluid pressure back to the hydraulic power supply. Install this valve (N) in the hydraulic supply line with a drain hose (A) teed into the hydraulic return line (F). Limit supply pressure to a maximum 900 psi (6.2 MPa, 62.1 bar)).

Accumulator (P): reduces hammering effect caused by the reciprocator when it reverses direction.

Fluid-filled Pressure Gauge (M), Part No. 112567: monitors hydraulic pressure to the reciprocator during startup. See FIG. 1. Use the gauge for initial adjustment of the reciprocator. It can be removed after adjustment.

Grounding



The equipment must be grounded to reduce the risk of static sparking. Static sparking can cause fumes to ignite or explode. Grounding provides an escape wire for the electric current.

- **Pump:** Use ground wire and clamp as shown in FIG. 1. Order Grounding Wire and Clamp Kit, Part No. 222011.
- **Hydraulic Hoses and Fluid Outlet Hoses:** Use electrically conductive hoses only.
- **Hydraulic Power Supply:** Follow manufacturer's recommendations.
- **Flushing Pails:** When flushing, only use metal, grounded pails. Make firm, metal-to-metal contact between the metal part of the dispense valve and the pail. Use lowest possible pressure.

Grounding the Pump (FIG. 1)

To ground pump:

1. Remove ground screw (Z) and insert through eye of ring terminal at end of ground wire.
2. Fasten ground screw back onto pump and tighten securely.
3. Connect other end of wire to the frame of the truck.

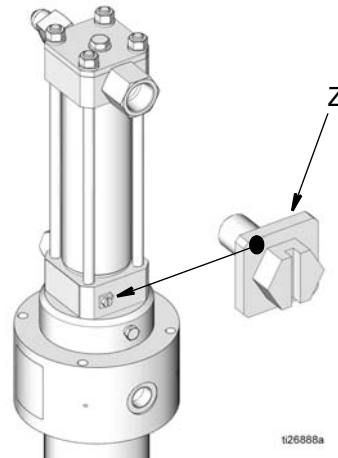

FIG. 1

Operation

Pressure Relief Procedure



Follow the Pressure Relief Procedure whenever you see this symbol.



This equipment stays pressurized until pressure is manually relieved. To help prevent serious injury from pressurized fluid, such as skin injection, splashing fluid and moving parts, follow the Pressure Relief Procedure when you stop dispensing and before cleaning, checking, or servicing the equipment.

1. Turn off hydraulic power supply (V).
2. Close supply line shut-off valve (L).
3. Open pump drain valve (D).
4. Verify pressure has been relieved by checking pressure gauge (Y).
5. Close shut-off valve (AA).

NOTE: Leave the drain valve (D) open until you are ready to dispense again.

Before Starting Pump



COMPONENT RUPTURE HAZARD

Overpressurizing any component can result in serious injury or property damage as a result of rupture, fire, and/or explosion. The maximum working pressure of each component in the system may not be the same. To reduce the risk of overpressurizing any component in the system:

- Be sure you know the maximum working pressure of each component.
- Never exceed the maximum working pressure of the lowest rated component in the system.
- Do not exceed the maximum input pressure.
- Use tubing, hoses and other components with pressure ratings equal to or higher than the pump rating.
- Do not exceed the maximum output pressure. The pump has a rated ratio of 10:1. However, it is capable of reaching stall pressures equal to 11.1 times the hydraulic input pressure. To calculate the fluid output pressure, multiply the hydraulic pressure shown on the hydraulic control module gauge by 11.1.

For example:

900 psi hydraulic x 11.1 = 10,000 psi fluid output

6.2 MPa hydraulic x 11.1 = 69 MPa fluid output



62.05 bar hydraulic x 11.1 = 689 bar fluid output

- Do not exceed the maximum pump cycle rate.
- Regulate hydraulic pressure to the pump so that no fluid line component or accessory is overpressurized.
- Check hydraulic fluid level in hydraulic power supply before each use. Add fluid as necessary to fill the lines.
- Flush pump before using it for the first time to remove the light oil that was left in after factory testing to protect pump from corrosion. Be sure solvent used is compatible with the fluid to be pumped and the pump's wetted parts. See **Technical Data**, page 26. Flush until clean solvent comes out of hose.

Starting Pump

1. Turn on hydraulic power supply.
2. Open return line shut-off valve (H) first, then slowly open the hydraulic supply shut-off valve (L).
3. Adjust flow control valve (R) to limit the hydraulic flow to no more than 3 gpm (11 lpm), which is approximately 60 cycles per minute.
4. Adjust pressure reducing valve (N) to increase hydraulic inlet pressure from 50 to 900 psi (0.34 to 6.2 MPa, 3.4 to 62.1 bar).
 - Increasing inlet pressure, increases outlet pressure.
 - Decreasing inlet pressure, decreases outlet pressure.
5. Open drain valve while priming pump.
6. When pump is primed, close drain valve.

Always use lowest pressure possible to obtain desired results. This reduces pump wear.

				
Maximum Working Pressures				
To reduce the risk of serious injury, including fluid injection and splashing in the eyes or on the skin, which may be caused if a component ruptures:				
<ul style="list-style-type: none"> • Never exceed 900 psi (6.2 MPa, 62.1 bar) Maximum Hydraulic input Pressure to the reciprocator. • Never exceed 10,000 psi (69 MPa, 689 bar) Maximum Outlet Pressure from the displacement pump. • Accessories added to the pump fluid outlet side should have at least a 10,000 psi (69 MPa, 689 bar) Maximum Working Pressure. • Read and understand COMPONENT RUPTURE HAZARD instructions, page 7. 				

If the Pump Leaks at the Fluid Fittings

Tighten fittings (1, 5, 60) which are self-sealing and have replaceable o-rings. If leaking persists, change o-rings.

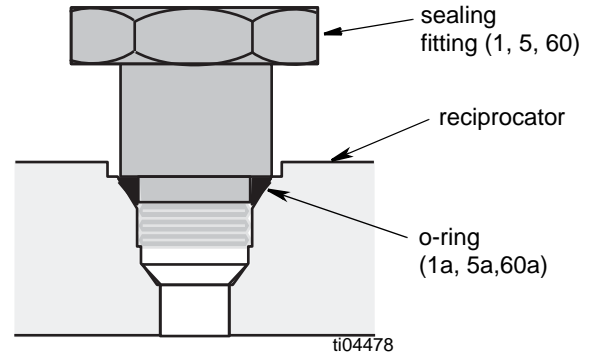

FIG. 2

Shutdown

Relieve pressure, page 7, whenever you shutdown.

Troubleshooting



Problem	Cause	Solution
Pump does not run.	Closed dispense valve.	Pump only runs with valve open.
	Pressure too low.	Increase supply pressure using a pressure adjusting valve.
	Insufficient hydraulic fluid supply.	Check hydraulic supply. Adjust to a maximum of 3 gpm (11 lpm) flow.
	Clogged fluid outlet line, intake valve, dispense valve, suction line.	Relieve pressure , page 7. Check. Clear obstructions.
	Reciprocator damaged.	Repair.
Pump speeds up or runs erratically.	Pump piston and/or intake valve worn.	Relieve pressure , page 7. Check and repair.
	Empty supply container.	Refill and repair. Do not allow pump to run dry. Monitor closely or use a low-level cutoff valve.
Pump runs but output low on up and/or down stroke.	Pump piston and/or intake valve worn.	Relieve pressure , page 7. Check and repair.
Pump run but output low on both up and down strokes.	Insufficient hydraulic fluid supply.	Check hydraulic supply. Adjust to maximum 3 gpm (11 lpm) flow.
	Pressure too low.	Increase supply pressure using a pressure adjusting valve.
	Clogged fluid outlet line, intake valve, dispense valve, suction line.	Relieve pressure , page 7. Check. Clear obstructions.
Excessive weepage from weep tube (B), page 4.	Worn throat packings.	Repair.
	Worn displacement seal.	Repair.
Hydraulic oil leaks from fittings in the upper or lower reciprocator blocks (31, 32) [Parts page 24].	Fittings 1, 5, 58, (Parts, page 24), are loose, or their o-rings are worn or damaged.	Tighten the self-sealing fittings. If leaking persists, change o-rings.

Service

NOTE: The reference letters used in the following Service instructions refer to the Typical Installation illustration provided on page 4.

The reference numbers used in the following Service instructions refer to the Parts pages beginning on page 22.

Pump Leaks at the Fluid Fittings



Tighten fittings (1, 5, 60; FIG. 3) which are self-sealing and have replaceable o-rings. If leaking persists, change o-rings.

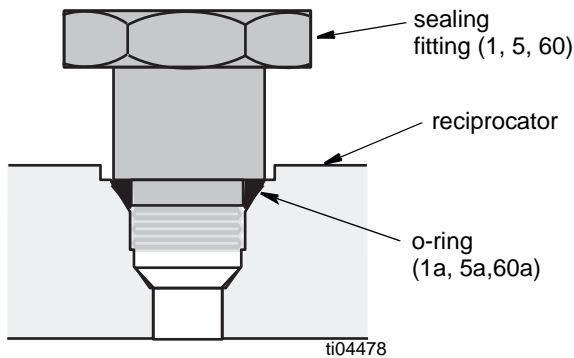

FIG. 3



Use of a hydraulic power supply with fluid temperatures above 154°F (68°C) can create hot surfaces which can burn if touched.

- Do not touch pump, motor, or if hydraulic system fluid is above 154°F (68°C).
- Allow sufficient time for pump and motor to cool before attempting any service or repair.

Removing Displacement Pump from Reciprocator

Disassembly

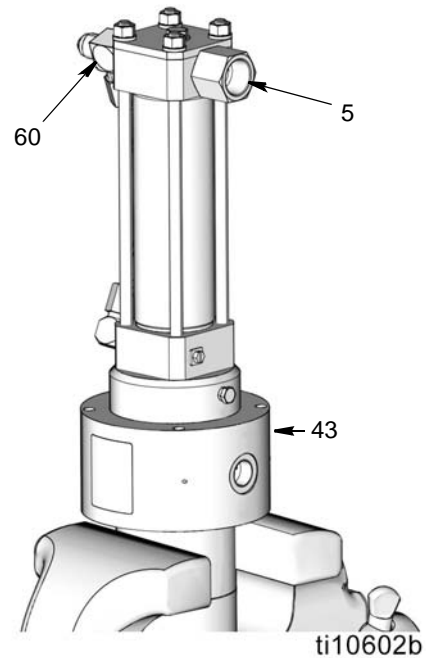

FIG. 4

1. Flush pump.
2. **Relieve pressure**, page 7.
3. Clamp reciprocator/pump assembly in a brass-jaw vise.
4. Disconnect fluid outlet hose (C) (Typical Installation, page 4) from displacement pump.
5. Slowly loosen hydraulic supply fitting (60) and return fitting (5) (FIG. 4). Remove hoses.
6. Install plugs in tube fittings and hose ends.

- Use a strap wrench on spacer tube (114) to unscrew it out of the pump adapter (8) and slide it down as far as it will go (FIG. 5).

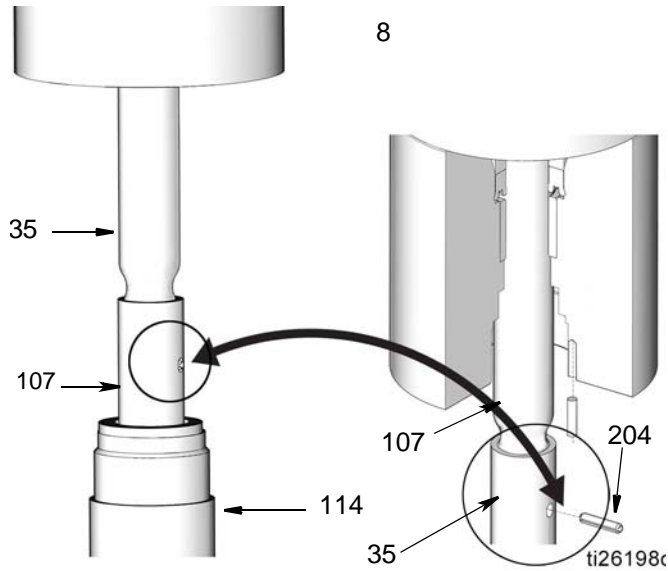

FIG. 5

- Pull connecting rod (107) out of spacer tube (114) to access the pin (204). Remove pin (204) (FIG. 5).
- Unscrew displacement rod (35) from connecting rod (107) from displacement rod (35) (FIG. 5).

Replacing Throat Seals



NOTE: Replace throat seals if fluid leaks excessively through the weep tube (B), page 4. This procedure can be done without disassembling entire reciprocator.

Disassembly

- Relieve pressure, page 7.
- Disconnect reciprocator from displacement pump (see Removing Displacement Pump from Reciprocator, page 10).
- Remove eight capscrews (15) and washers (27) from bottom of pump adapter (8). Tap pump adapter to loosen it and pull it off the motor housing (43) (FIG. 6).

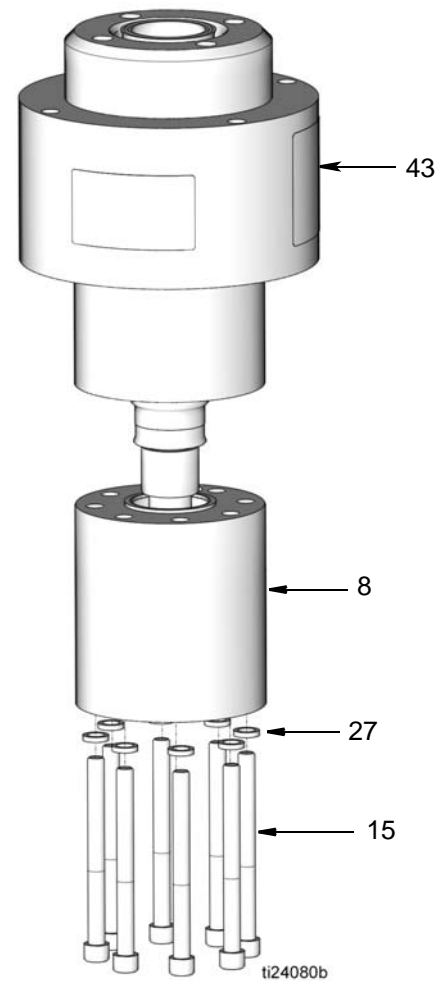

FIG. 6

- Remove retainer nut (11) and seal (44) from top of pump adapter (8).

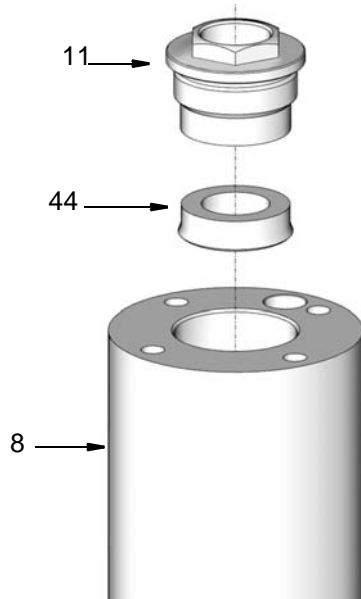

FIG. 7

- Remove four capscrews (46) and washers (52) from bottom of motor housing (43) and remove motor housing from bottom cylinder cap (32).

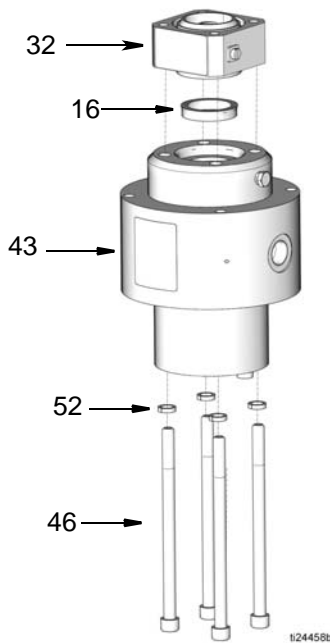

FIG. 8

- Loosen nut (45a) on both ends of fluid tube (45) (FIG. 9).

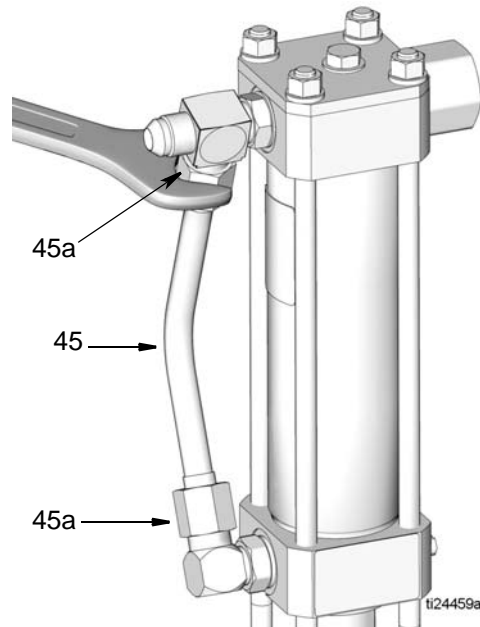

FIG. 9

- Use a wrench to loosen elbow (1) and tee (60). Remove fluid tube (45). Install plug in each fitting to prevent contamination (FIG. 10).

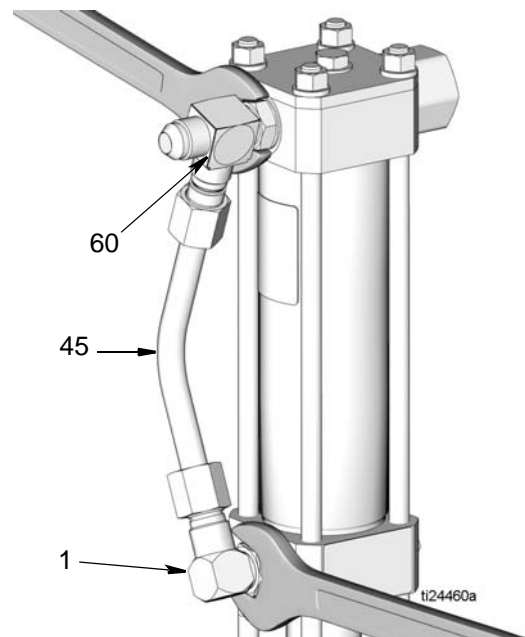

FIG. 10

8. Check o-rings (1a and 60a) on fittings (1 and 60) and replace them if they are worn or damaged.

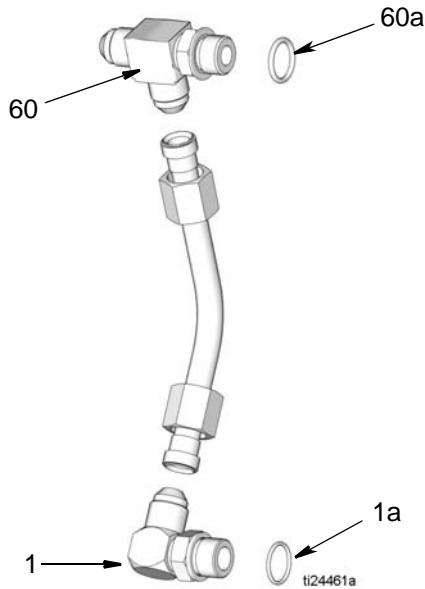

FIG. 11

9. Remove capscrew (3), nut (36) and lockwashers (37). Remove the reciprocator cap plate (30).

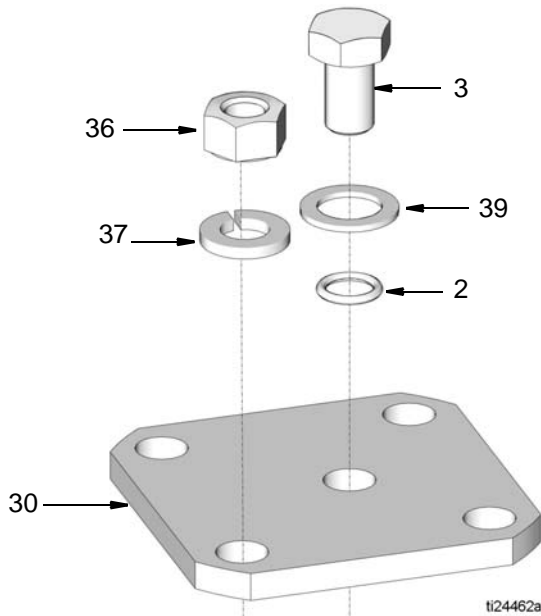

FIG. 12

10. Gently tap on bottom cylinder cap (32) to loosen cylinder cap from cylinder (25) using a rubber or plastic mallet.

NOTE: It is not necessary to remove the tie rods (38) from the bottom cylinder cap (32).

11. Remove seal (16) from bottom of cylinder cap (32).

Reassembly

Use Kit 247455. Use all new parts included in the kit.

1. Install seal (16) in bottom of cylinder cap (32) in the orientation shown in FIG. 13.

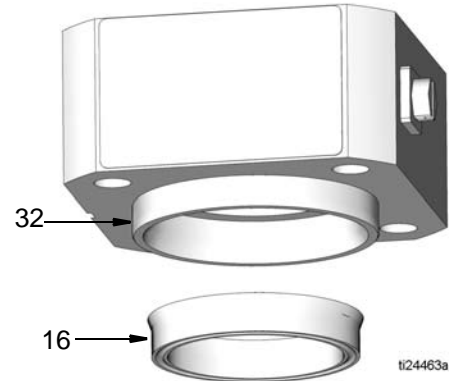

FIG. 13

2. Reassemble cylinder cap (32) to motor housing (43). Install lock washers (52) and cap screws (46) (FIG. 13). Torque the capscrews to 28-32 ft-lb (38 to 43 N.m).

NOTE: When attaching the motor housing (43) onto the bottom cylinder cap (32), be sure that the port (43b) in the motor housing and the port (32b) in the bottom cylinder cap are facing opposite directions as shown in FIG. 14.

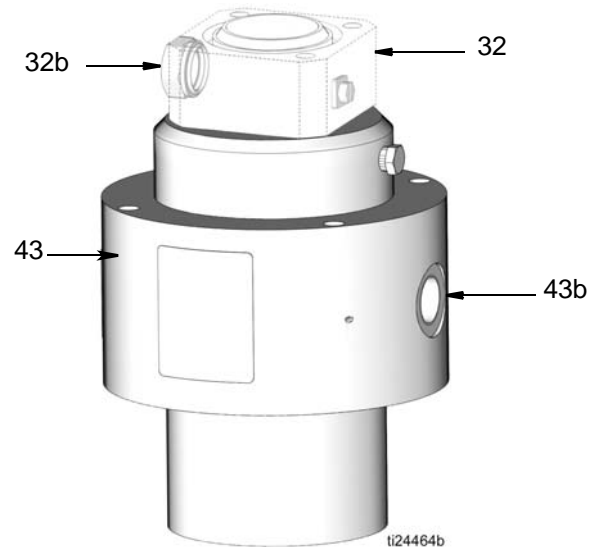

FIG. 14

3. Install seal (44) on retainer nut (11). Install retainer nut in pump adapter (8) (FIG. 14). Torque retainer nut to 54 to 56 ft-lbs (73-75 N.m).
4. Slide bottom cylinder cap (32) onto the cylinder (25) ensuring the tie rods (38) go through their respective holes in the top cylinder cap (31).

NOTE: When attaching the bottom cylinder cap (32) onto the cylinder (25) be sure that the port (31b) in the top cylinder cap (31) and the port (32b) in the bottom cylinder cap (32) are in line with each other. Be sure o-rings (13) are in place in the top and bottom cylinder caps as shown in FIG. 15.

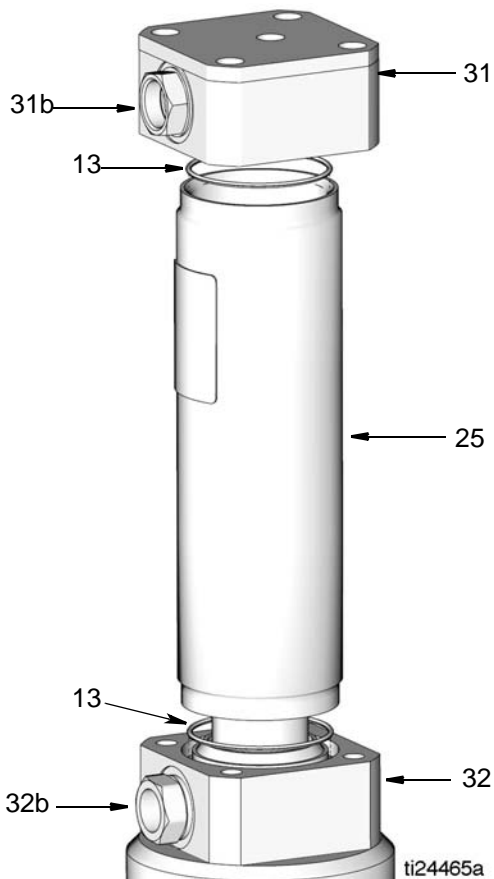

FIG. 15

5. Install lock washers (37) and nuts (36) onto tie rods (38). Torque nuts to 28-32 ft-lbs (38-43 N.m) (FIG. 16).

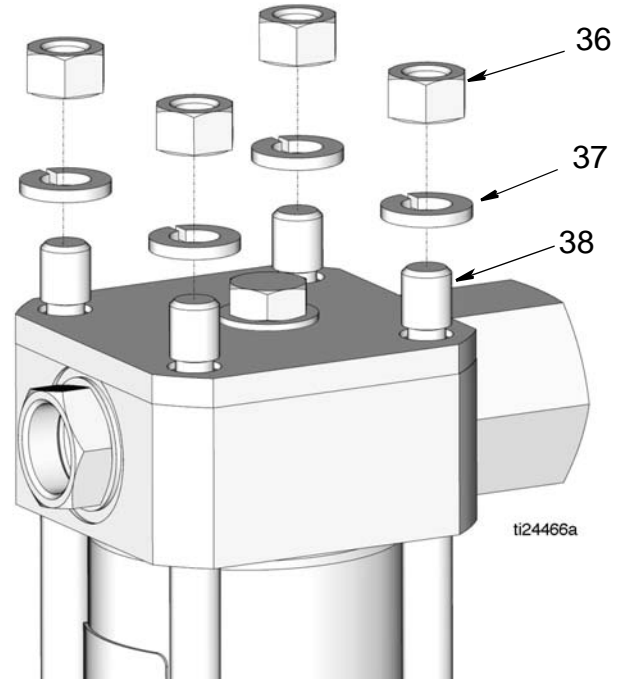

FIG. 16

6. Install pump adapter (8) to motor housing (43). Install the lockwashers (27) and capscrews (15). Torque capscrews to 170-180 in.-lbs (19-20 N.m).
7. Reinstall fluid tube (45) and fittings (1). Torque fittings to 28 to 32 ft-lb (38 to 43 N.m.)
8. Install displacement pump, see Displacement Pump and Reciprocator Reassembly instructions, page 20.

Reciprocator Repair

- Clean and inspect all parts for wear or damage. Replace worn parts as needed. For best results, always replace all the o-rings and seals when you disassemble the pump. **Repair Kit 247455** is available. Parts included in the kit are marked with an asterisk, for example (23*), in the text and drawings. Always replace seals (23* and 24*) and seals (16* and 44*) together.
- **Assembly tool 189305** is required for reassembling the reciprocator.
- Loctite® 242 thread sealant and Loctite® Primer T or Perma-Loc® 115 thread sealant and Perma-Bond® Surface Conditioner I are required. Be sure their shelf life is within the manufacturer's recommendations.
- For Step 8, page 17; use Loctite® 609 on yoke (9) and rod (12). On all other threaded surfaces, use Loctite® 242 or Perma-Loc® 115 as required.

Disassembly



1. **Relieve pressure**, page 7.
2. Drain oil out of reciprocator.
3. Disconnect reciprocator from displacement pump (see Removing Displacement Pump from Reciprocator, page 10). Place reciprocator in a drain pan.
4. Remove eight capscrews (15) and washers (27) from bottom of pump adapter (8). Tap pump adapter to loosen it and pull it off the motor housing (43) (FIG. 6).

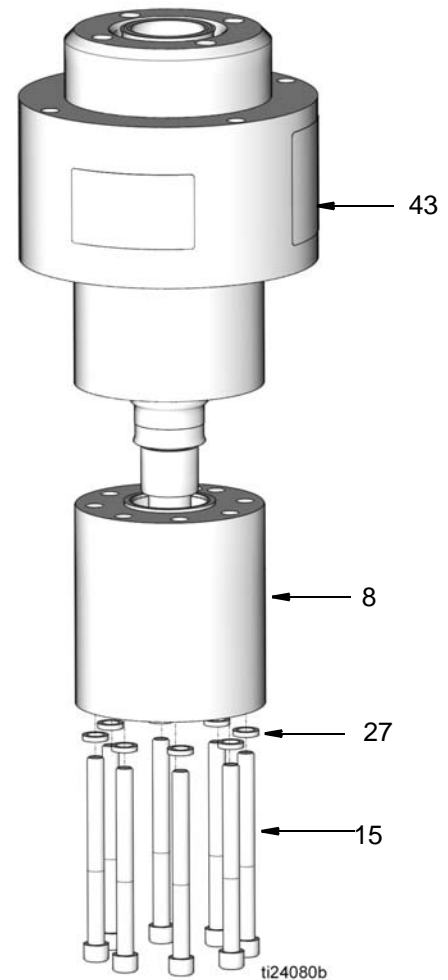

FIG. 17

- Place bottom cap (32) in vise. Remove four cap-screws (46) and lockwashers (52).

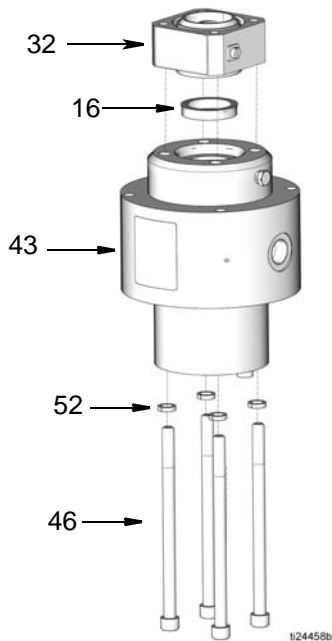

FIG. 18

- Pull adapter (43) off bottom cap (32). Inspect seals. If needed, replace seals. See Replacing Throat Seal Disassembly instructions on page 11.
- Remove capscrew (3), nuts (36) and lockwashers (37) on top of reciprocator.

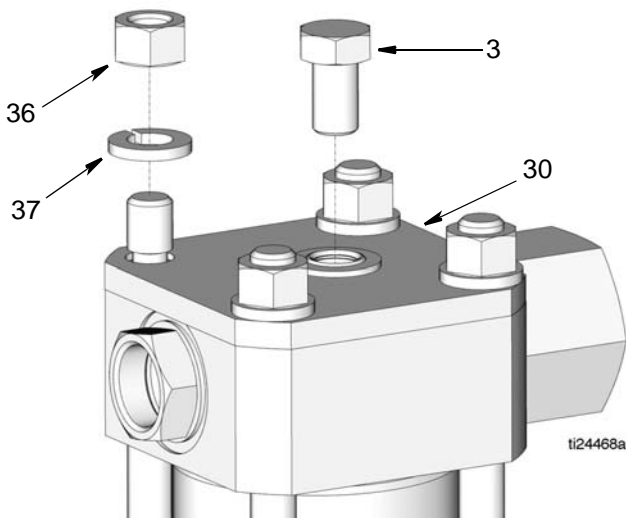

FIG. 19

- Remove cap plate (30) (FIG. 19).

- Use a rubber or plastic head mallet to tap the bottom of the displacement rod (35) and loosen cylinder (25).

- Grasp top of cylinder cap (31) and pull the displacement rod (35) out of the cylinder (25). Lay assembly on its side.

NOTE: It is not necessary to remove tie rods (38) from the bottom cylinder cap (32).

- Place a clean rag around yoke (9) to prevent losing detent balls (7) and spring (6) installed in the valve stop (26). Lightly push down the valve stop with your thumbs while gripping yoke to disengage yoke from valve stop and valve sleeve (29).

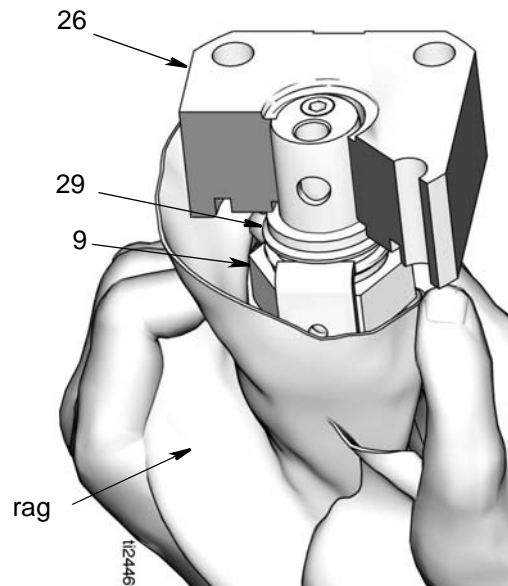

FIG. 20

- Secure hex end of displacement rod (34) in a vise. Use a spanner wrench (sw) in pin holes of the piston (22) to remove piston from the displacement rod.

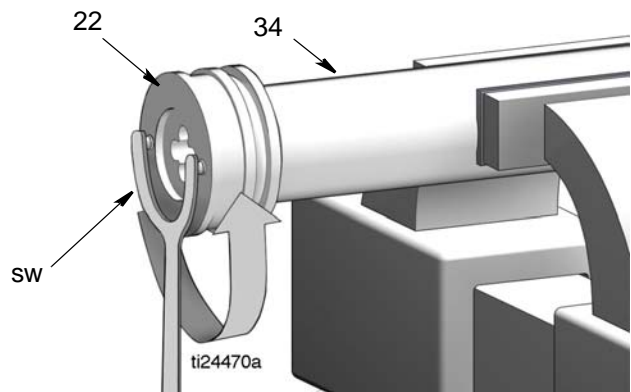

FIG. 21

13. Visually inspect the spring (21). If there is wear or damage, remove nut (18), spring (21) and retainers (20) from the trip rod (12) (FIG. 22).

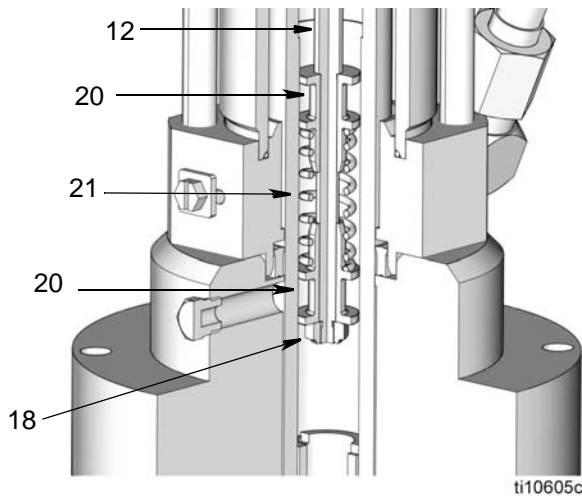

FIG. 22

Reassembly

NOTE:

- Use a surface cleaner such as chlorinated solvent on the threads of all parts that are being reused for reassembly. Blow part with compressed air.
 - Use a 1/4-28 UNF-2A tap to remove adhesive from internal threads of yoke (9).
 - Thread sealer and primer are required. See Reciprocator Repair Notes, page 15 for specification.
 - Loctite® 609 is used only in Step 3 of this procedure.
1. If needed, install a new spring over trip rod as follows (FIG. 23):
 - one retainer (20),
 - new spring (21),
 - second retainer (20).

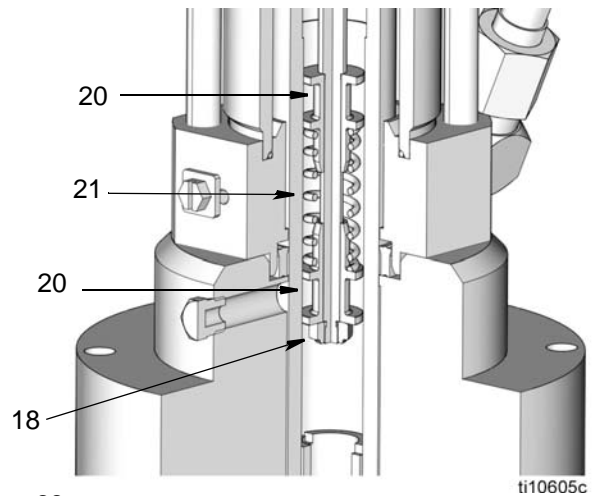

FIG. 23

2. Thread nut (18) onto rod until it runs out of thread so that it bottoms out on the rod's shoulder (FIG. 23).
3. If valve yoke (9) was removed from trip rod (12) during the disassembly procedure, apply Loctite® 609 thread sealant to first two or three internal threads of yolk (9).
4. Apply Primer to external threads of trip rod (12). Allow Primer 3-4 minutes to dry. Install trip rod to yoke (9). Torque to 54-56 in.-lbs (6.1 to 6.3 N.m). Remove excess sealant.
5. Apply Loctite® 242 or Perma-Loc 115 thread sealant to first two to three threads of valve assembly (31).
6. If capscrews (51) were removed during the disassembly procedure, apply thread sealant to the first two or three internal threads of valve stop (26) (FIG. 24, page 18).
7. Apply Primer to external threads of valve sleeve (29). Allow Primer 3-4 minutes to dry. Install cap screws (51). Torque to 42-45 in.-lbs (4 to 5 N.m). Remove excess sealant.

NOTICE

In order to ensure a tight and secure seal, allow 24 hours for sealant applied in Steps 3 and 5 to cure before operating reciprocator.

8. Remove o-ring (13) from bottom of cylinder cap (31) and replace it with a new o-ring.

9. Use a spanner wrench to screw piston (22) onto displacement rod (34). Torque to 40 to 48 ft-lb (54 to 65 N.m).
10. Lay Assemblies A and B (FIG. 24) on work bench.

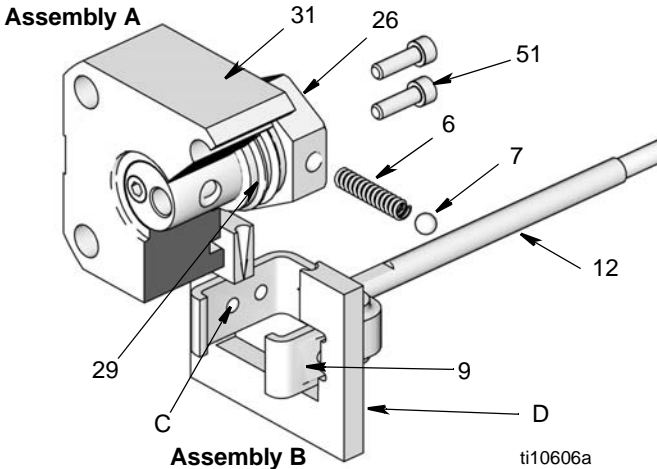

FIG. 24

11. Slide Assembly B in into center of tool (D), Part No. 189305. Align upper detent holes (C) of yoke (9) with center line of tool (D) (FIG. 24).
12. Insert spring (6) and one ball (7) into valve stop (26) of Assembly A. Tilt valve stop and start guiding it into tool (D), making sure ball is sliding into rounded slot in tool (D). Place other ball at the other end of spring and push it in with your thumb while rotating valve stop (26) until spring is horizontal and balls are in place. Continue holding this assembly together (FIG. 24).
13. Slide valve stop assembly down into tool. Make sure balls (7) snap into upper set of holes (C) in yoke (9) and curved ends of guide clamp have engaged valve sleeve (29) groove. Slide tool (D) back over rod (12) to remove it (FIG. 24).
14. Place adapter (43) in a vise. Install seals as described in Replacing Throat Seal Reassembly instructions, page 13.
15. Reassemble cylinder cap (32) to motor housing (43). Install lock washers (52) and cap screws (46) (FIG. 13). Torque the capscrews to 28-32 ft-lb (38 to 43 N.m).

NOTE: When attaching the motor housing (43) onto the bottom cylinder cap (32), be sure that the port (43b) in the motor housing and the port (32b) in the bottom cylinder cap are facing opposite directions as shown in FIG. 25.

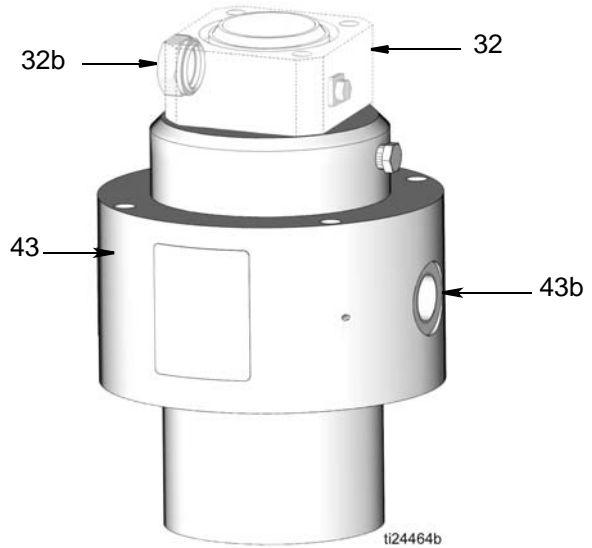

FIG. 25

16. Attach adapter (8) to motor housing (43) using eight capscrews (15) and lock washers (27). Torque capscrews to 25-30 ft-lbs (34-41 N.m).

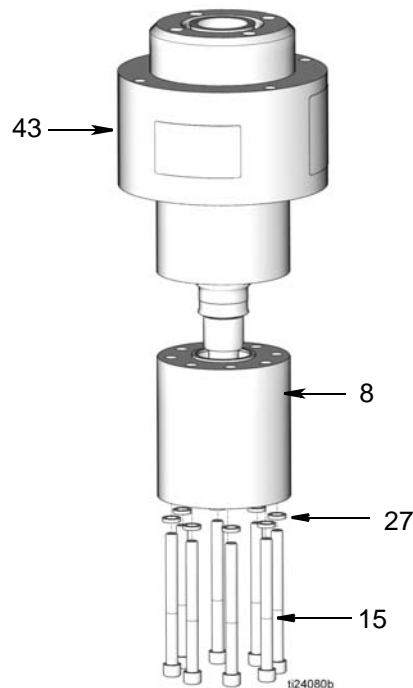

FIG. 26

17. If tie rods (38) were removed, reinstall them with short threaded end up. The other end should be screwed about 9/16" into bottom cylinder cap (32).

When reinstalling cylinder (25), be sure port in top cylinder cap (31) and port in the bottom cylinder cap (32) are in line with each other. Be sure o-rings (13) are in place in the top and bottom and cylinder caps (31 and 32).

18. Place cylinder (25) on cylinder cap (32).
19. Install o-ring (49) in deep, lower groove of piston (22). Install seal (23) over o-ring. Install piston bearing (24) around upper groove of piston. Holding piston bearing in place to avoid damage, slide cylinder over piston and press it down.
20. Install cap plate (30).
21. Install capscrew (3), o-ring (39) and washer (2). Install lockwashers (37) and nuts (36). Torque nuts to 28 to 32 ft-lb (38 to 43 N.m).
22. Reinstall fluid tube (45) and fittings (1). Torque fittings to 28 to 32 ft-lb (38 to 43 N.m).

NOTE: Make sure the displacement rod (35) on the assembled reciprocator is exposed so the pump can be connected to it.

Displacement Pump Repair

Disassembly

- Be sure you have all necessary parts on hand before you start. If using a repair kit, use all parts in the kit for the best results.
- Displacement Pump Repair Kit 241623 is available. Parts included in the kit are marked with a dagger (†) symbol in the parts drawing and list, page 26.

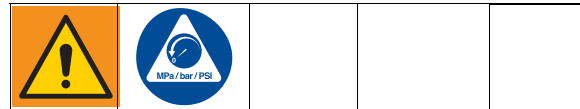

1. If possible, flush pump.
2. **Relieve pressure**, page 7.
3. Follow instructions for **Removing Displacement Pump from Reciprocator**, page 10.

NOTICE

To avoid damaging shovel tube, do not use slots in tube to tighten or loosen tube.

4. Clamp pump in vise.
5. Use wrench to screw shovel tube (117) off pump cylinder (109).
6. Use a wrench to screw piston shovel (116) off of shovel rod (108).
7. Use strap wrench on pump cylinder (109) to screw it out of extension tube (114).
8. Use a 7/8 inch crow foot connector wrench to screw retainer seal (113) out of pump cylinder (109). Remove bearing (111) and seal (112).
9. Screw the shovel rod (108) out of the piston (102). Remove lower ball (106).
10. Screw piston (102) out of extension rod (107). Remove upper ball (106†), retaining washer (103) and seal (104).

Reassembly

1. Clean all the parts in a compatible solvent and inspect them for wear or damage. Use all parts in the repair kit, replace other parts as necessary.
2. Generously lubricate all parts with light, water-resistant grease.
3. Install upper ball (106), retaining washer (103) and seal (104), with lips facing up, in extension rod (107). Screw piston (102) into extension rod (107). Torque the piston to the extension rod to 25-30 ft-lb (34-41 N.m).
4. Install lower ball (106) into end of shovel rod (108). Screw the shovel rod (108) to piston (102). torque the shovel rod to the piston to 25-30 ft-lb (34-41 N.m).
5. Install bearing (111) and seal (112) with lips facing up, in pump cylinder (109). Screw retainer seal (113) into pump cylinder (109).
6. Screw together pump cylinder (109) and extension tube (114). Use a 7/8 inch crow foot wrench on retainer seal (113). torque to 45-55 ft-lb (61-75 N.m) (FIG. 27).

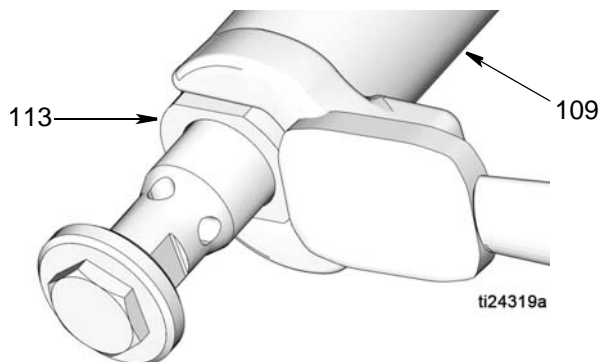

FIG. 27

7. Use a wrench to screw together piston shovel (116) and shovel rod (108). Torque to 145-155 in.-lb (16.4-17.5 N.m).

Reassembling Displacement Pump to Reciprocator

1. Clamp reciprocator in vise.
2. Replace nylon pellet (207) in threads on bottom of pump adapter (8) (FIG. 28).

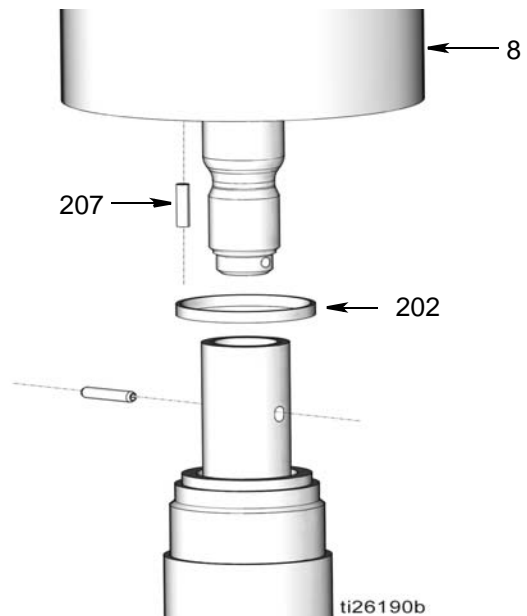

FIG. 28

3. Install new gasket (202) in pump adapter (8) (FIG. 28).

- Screw connecting rod (107) into displacement rod (35) until holes align. Install cotter pin (204) through holes.

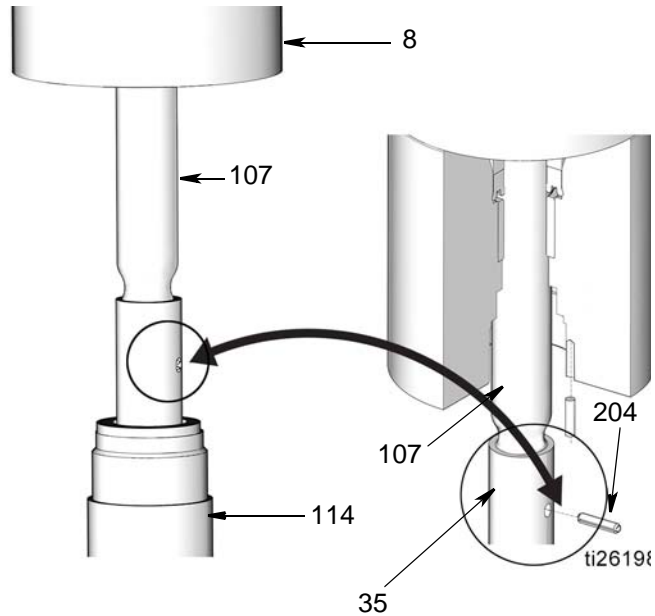

FIG. 29

- Apply thread lubricant to spacer tube (114) and thread into pump adapter (8). Use a 7/8 inch crow foot wrench on retainer seal (113). torque to 45-55 ft-lb (61-75 N.m) (FIG. 27).

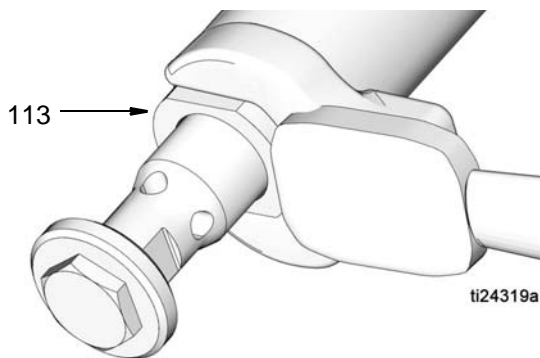

FIG. 30

- Use a strap wrench to screw together shovel tube (117) and pump cylinder (109).
- Connect hydraulic supply and return hoses to fittings (5, 60).

To reduce risk of static sparking, be sure to reconnect ground wire before operating pump.				

Parts

Displacement Pump Model 25A191: 120# Drum Length

Ref No.	Part No.	Description	Qty
102	17J113	PISTON	1
103	196185	WASHER, retainer	1
104†	114171	PACKING, u-cup	1
106†	100065	BALL	2
107	25A142	ROD, connecting	1
108	192540	ROD, shovel	1
109	25A165	CYLINDER, pump	1
110†	25A167	GASKET, seal	1
111†	192534	BEARING	1
112†	114178	PACKING, u-cup	1
113	192531	RETAINER, seal	1
114	25A166	TUBE, spacer	1
116	192660	PISTON, shovel	1
117	17A265	TUBE, shovel	1

† These parts are included in Kit 241623 (purchase separately).

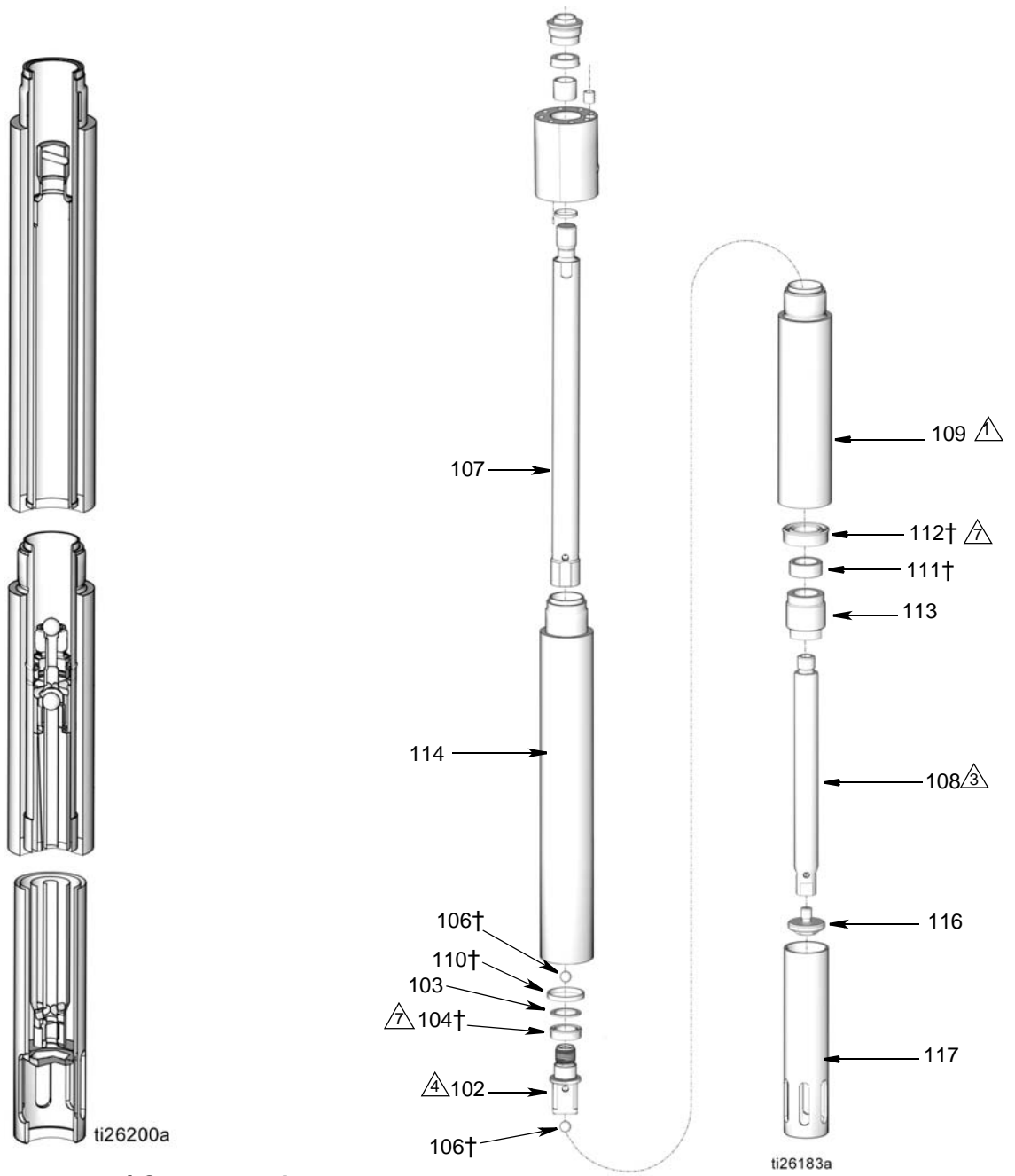

Assembled / Cutaway View

- 1 Using nut (113), torque the pump cylinder 109 to the extension tube (114) at 45 to 55 ft-lb (61 to 75 N.m).
- 2 Torque the shovel rod (108) to the piston (102) at 25 to 30 ft-lb (34 to 41 N.m).
- 3 Torque the piston (102) to the extension rod (107) at 25 to 30 ft-lb (34 to 41 N.m).
- 4 Assemble with lips facing up.

FIG. 31

Parts

Reciprocator Model 25A190

Ref. No.	Part No.	Description	Qty.
1	106470	ELBOW, straight thread, 3/4-16 unf-2a x 3/4-16 unf-2a, 37° flare includes item 1a	1
1a	110987	O-RING	1
2	178179	WASHER, sealing	1
3	160276	CAPSCREW, hex hd, 3/8-24 x 5/8"	1
4*	104093	O-RING	1
5	112568	ADAPTER, pip, 3/4 unf (m) 1/2 NPT (f), steel, includes item 5a	1
5a	110987	O-RING	1
6	108437	SPRING, compression, steel	1
7	100069	BALL, 1/4" dia. steel	2
8		ADAPTER, pump	1
9	189077	YOKE, valve	1
10*	15M389	GASKET, seal	1
11	192537	NUT, retainer	1
12		ROD, trip	1
13*	106274	O-RING, buna-N	2
14	116343	SCREW, grounding	1
15	113194	SCREW, cap, socket hd	8
16*	108952	PACKING, v-block	1
17	105765	O-RING	2
18	114231	LOCKNUT, hex, 1/4-28 unf-3b steel and nylon	1
19	193757	BEARING	1
20		RETAINER, spring	2
21	178189	SPRING, compression, steel	1
22	192656	PISTON, cs	1
23*	178226	SEAL, piston, glass-filled PTFE	1
24*	178207	BEARING, piston, bronze-filled PTFE	1
25	178229	CYLINDER, motor, cs	1
26	192654	STOP, valve, cs	1
27	104008	WASHER, lock, spring	8
28	100139	PLUG, pipe	1
29	189072	SLEEVE, valve, steel	1
30	178181	PLATE, cap	1
31	178176	CAP, cylinder, top	1
32	186225	CAP, cylinder, bottom	1
34	188078	ROD, displacement	1
35		ROD, displacement	1
36	100307	NUT, full, hex; 3/8-16 unc-2b	4

Ref. No.	Part No.	Description	Qty.
37	100133	LOCKWASHER, 3/8"	4
38	187405	ROD, tie, 8.5" shoulder to shoulder, 3/8-16 unc-2a, cs	4
39	155685	O-RING	1
40▲	128583	LABEL, Warning	1
43		HOUSING, motor	1
44*†	114179	PACKING, u-cup	1
45	217221	TUBE, inlet	1
46	125775	CAPSCREW, sch, 3/18-16 unc-2a x 4.5"	4
49*	108014	PACKING, o-ring	1
51	104092	CAPSCREW, sch; 10-24, unrc-3a x 5/8"	2
52	106115	LOCKWASHER, spring, 3/8"	4
58	110064	PLUG, pipe, vented, 1/8-27 NPT (f)	1
60	107197	TEE, includes item 60a	1
60a	110987	O-RING	1
61	192653	VALVE, spool	1
66	103147	PLUG, pipe	1
71▲	189285	LABEL, hot surface	1

▲ Replacement Danger and Warning labels, tags, and cards are available at no cost.

* These parts and items 202 on page 26 are included in Kit 247455 (purchase separately).

† These parts are included in Kit 241623 (purchase separately).

Assembly Tool 189305 required for repairing the reciprocator.

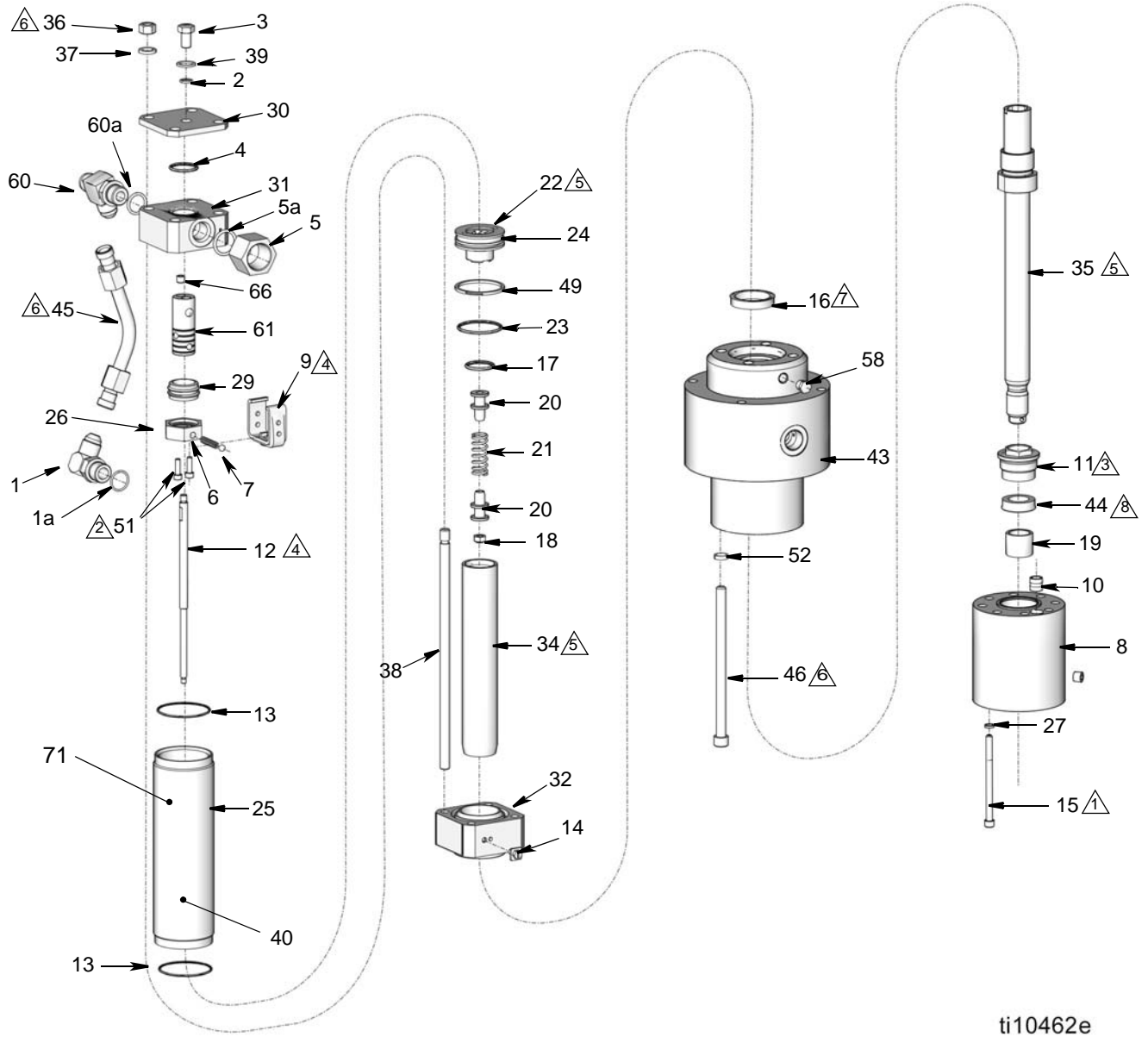

ti10462e

- ① Torque to 276-324 in-lbs (31-37 N.m)
- ② Torque to 42-45 in-lbs (4-5 N.m).
- ③ Torque to 54-56 ft-lbs (73-76 N.m).
- ④ Torque to 54-56 in-lbs (6.0-6.5 N.m).

- ⑤ Torque to 40-48 ft-lbs (54-65 N.m)
- ⑥ Torque to 28-32 ft-lbs (38-43 N.m).
- ⑦ Assemble with lips facing up.
- ⑧ Assemble with lips facing down.

FIG. 32

Parts

Pump Model 25A189: 120# Drum Length

Ref No.	Part No.	Description	Qty
201		RECIPROCATOR, page 24	1
202*	25A168	SEAL, gasket	1
204	108513	PIN	1
205		DISPLACEMENT PUMP	1
206	183741	LABEL, identification	1
207*	160742	PELLET, nylon	1

* These parts are included in Kit 247455 (purchase separately). See page 24 for other parts included in this kit.

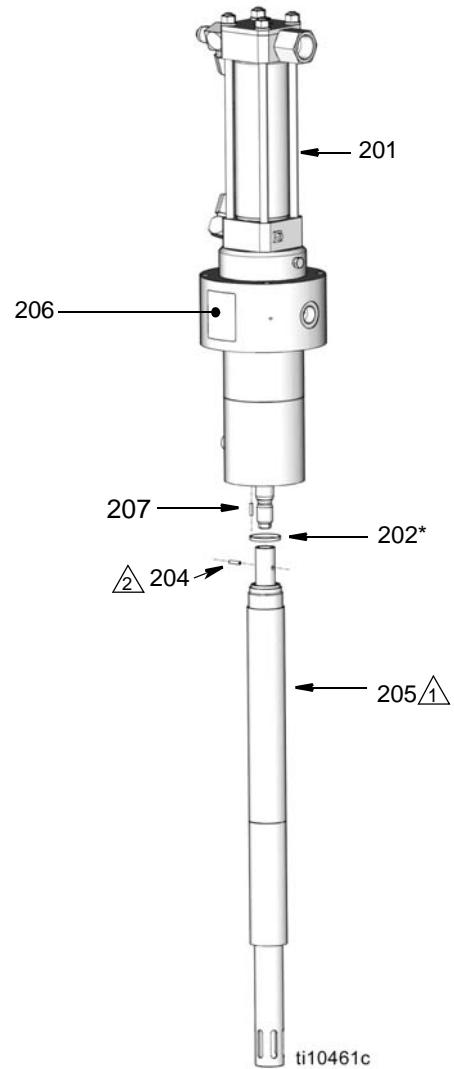

- ⚠ Apply thread lubricant, Part No. 070268 to threads and torque to 55-65 ft. lbs (74.5 to 88.1 N.m)
- ⚠ Coupling joint should have free play after pin (204) is installed

FIG. 33

Technical Data

Dyna-Star Hydraulic Reciprocator and High Pressure Pump		
	US	Metric
Maximum grease output pressure	10,000 psi	69 MPa, 689 bar
Maximum hydraulic input pressure	900 psi	6.2 MPa, 62.1 bar
Maximum hydraulic fluid input volume, 60 cpm	3 gpm	11 lpm
Hydraulic fluid consumption rate	6.5 ounces per cycle	0.195 l per cycle
	1 gallon per 195 cycles	
Maximum fluid temperature	250°F	121°C
Output per cycle	0.6 in ³ / cycle	
Maximum flow rate	1.1 lbs/min @60 cycles/minute	
Stroke	3 in.	76.3 mm
Sound Pressure	77 dB(A)	
<i>Sound pressure measured with pump operating at 66 cycles per minute.</i>		
<i>Sound power measured per CAGI-PNEUROP, 1971.</i>		
Materials of Construction		
Hydraulic reciprocator wetted parts	steel, buna-N rubber, glass and bronze filled PTFE, nylon, polyurethane	
Weight		
	58 lb.	26 kg
Notes		
Loctite® is a registered trademark of the Loctite Corporation.		

Typical Fluid Outlet Pressure

A = 900 psi 62 Bar 6.2 Mpa Hydraulic inlet pressure
 B = 600 psi 41 Bar 4.1 Mpa Hydraulic inlet pressure
 C = 300 psi 21 Bar 2.1 Mpa Hydraulic inlet pressure

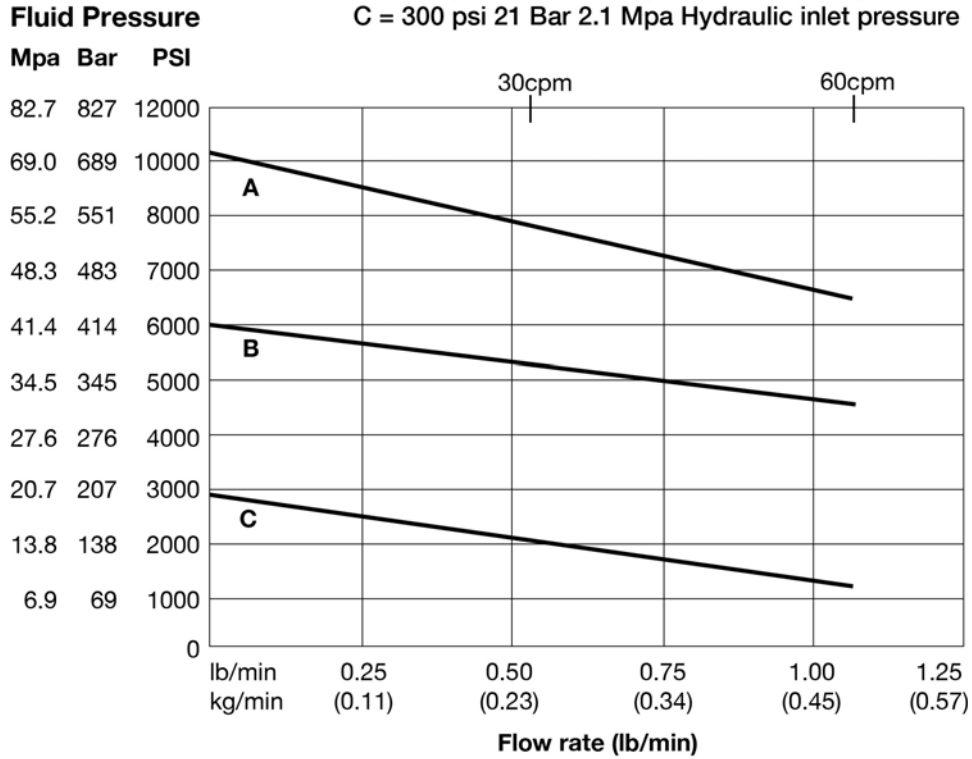

Dimensions and Mounting Hole Layout

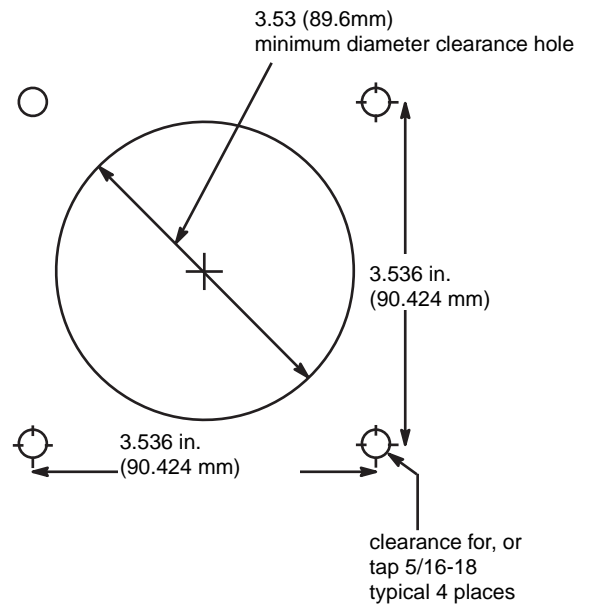
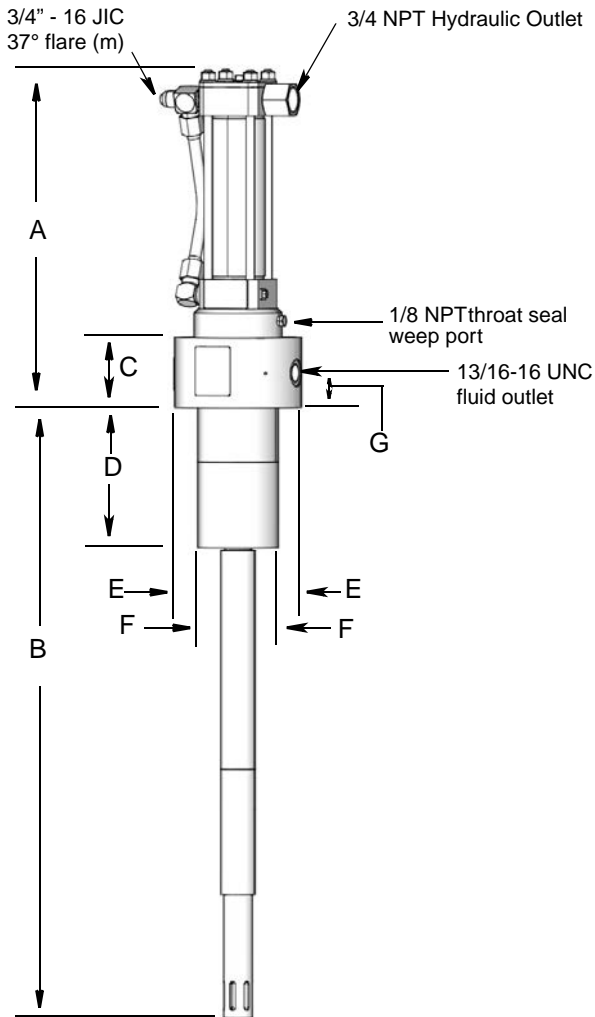

ti25402

Ref.	Inches	MM
A	14.107	358.3
B	26.5	673.1
C	3.03	76.96
D	5.04	128.0
E	5.5	139.7
F	3.5	88.9
G	1.53	38.86

Graco Standard Warranty

Graco warrants all equipment referenced in this document which is manufactured by Graco and bearing its name to be free from defects in material and workmanship on the date of sale to the original purchaser for use. With the exception of any special, extended, or limited warranty published by Graco, Graco will, for a period of twelve months from the date of sale, repair or replace any part of the equipment determined by Graco to be defective. This warranty applies only when the equipment is installed, operated and maintained in accordance with Graco's written recommendations.

This warranty does not cover, and Graco shall not be liable for general wear and tear, or any malfunction, damage or wear caused by faulty installation, misapplication, abrasion, corrosion, inadequate or improper maintenance, negligence, accident, tampering, or substitution of non-Graco component parts. Nor shall Graco be liable for malfunction, damage or wear caused by the incompatibility of Graco equipment with structures, accessories, equipment or materials not supplied by Graco, or the improper design, manufacture, installation, operation or maintenance of structures, accessories, equipment or materials not supplied by Graco.

This warranty is conditioned upon the prepaid return of the equipment claimed to be defective to an authorized Graco distributor for verification of the claimed defect. If the claimed defect is verified, Graco will repair or replace free of charge any defective parts. The equipment will be returned to the original purchaser transportation prepaid. If inspection of the equipment does not disclose any defect in material or workmanship, repairs will be made at a reasonable charge, which charges may include the costs of parts, labor, and transportation.

THIS WARRANTY IS EXCLUSIVE, AND IS IN LIEU OF ANY OTHER WARRANTIES, EXPRESS OR IMPLIED, INCLUDING BUT NOT LIMITED TO WARRANTY OF MERCHANTABILITY OR WARRANTY OF FITNESS FOR A PARTICULAR PURPOSE.

Graco's sole obligation and buyer's sole remedy for any breach of warranty shall be as set forth above. The buyer agrees that no other remedy (including, but not limited to, incidental or consequential damages for lost profits, lost sales, injury to person or property, or any other incidental or consequential loss) shall be available. Any action for breach of warranty must be brought within two (2) years of the date of sale.

GRACO MAKES NO WARRANTY, AND DISCLAIMS ALL IMPLIED WARRANTIES OF MERCHANTABILITY AND FITNESS FOR A PARTICULAR PURPOSE, IN CONNECTION WITH ACCESSORIES, EQUIPMENT, MATERIALS OR COMPONENTS SOLD BUT NOT MANUFACTURED BY GRACO. These items sold, but not manufactured by Graco (such as electric motors, switches, hose, etc.), are subject to the warranty, if any, of their manufacturer. Graco will provide purchaser with reasonable assistance in making any claim for breach of these warranties.

In no event will Graco be liable for indirect, incidental, special or consequential damages resulting from Graco supplying equipment hereunder, or the furnishing, performance, or use of any products or other goods sold hereto, whether due to a breach of contract, breach of warranty, the negligence of Graco, or otherwise.

FOR GRACO CANADA CUSTOMERS

The Parties acknowledge that they have required that the present document, as well as all documents, notices and legal proceedings entered into, given or instituted pursuant hereto or relating directly or indirectly hereto, be drawn up in English. Les parties reconnaissent avoir convenu que la rédaction du présente document sera en Anglais, ainsi que tous documents, avis et procédures judiciaires exécutés, donnés ou intentés, à la suite de ou en rapport, directement ou indirectement, avec les procédures concernées.

Graco Information

For the latest information about Graco products, visit www.graco.com.

For patent information, see www.graco.com/patents.

TO PLACE AN ORDER, contact your Graco distributor or call to identify the nearest distributor.

Phone: 612-623-6928 **or Toll Free:** 1-800-533-9655, **Fax:** 612-378-3590

*All written and visual data contained in this document reflects the latest product information available at the time of publication.
Graco reserves the right to make changes at any time without notice.*

Original instructions. This manual contains English. MM 3A3005

Graco Headquarters: Minneapolis

International Offices: Belgium, China, Japan, Korea

GRACO INC. AND SUBSIDIARIES • P.O. BOX 1441 • MINNEAPOLIS MN 55440-1441 • USA
Copyright 2015, Graco Inc. All Graco manufacturing locations are registered to ISO 9001.

www.graco.com

Revision B, March 2016