

# Hopper Installation Kit

333507C  
EN

For gravity feeding material to Xtreme® XL Sprayers and Xtreme Sprayers.  
For professional use only.

## Part No. 24X570



### Important Safety Instructions

Read all warnings and instructions in Xtreme or Xtreme XL Sprayer manual. Save all instructions.

### Parts

Ref. Part	Description	Qty
1	17E114 HOPPER	1
2	17C474 BRACKET	1
3	17D554 BRACKET, upper	1
4	126939 ELBOW, 90°	1
5	128095 CAM/GROOVE	1
6	17C692 FITTING, cam/groove, 1.5 m, 1-1/2 npt	1
7	128094 BUSHING	1
8	112395 SCREW	4
9	112958 NUT	4
10	120781 GASKET	1
11	110110 SEALANT, 6ml	1
12	15M987 ELBOW, 60°	1
13	16U537 LID (not shown)	1

### Xtreme Sprayer with Dura-Flo™ Pump

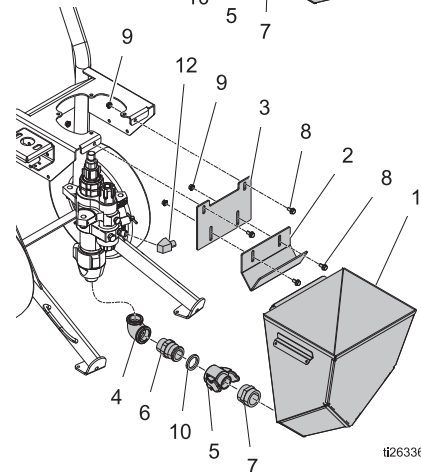
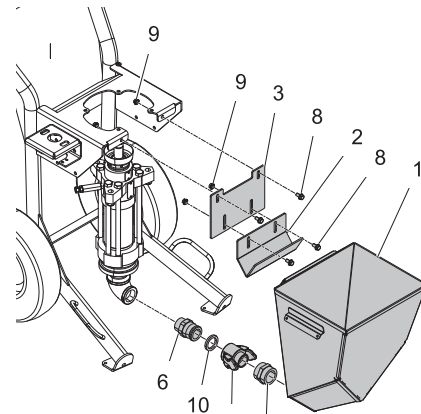



### Xtreme Sprayer with Xtreme Pump

# 24X570 Installation

## Required Tools

- Reciprocating saw with steel cutting blade (sawzall)
- Drill
- 7/16 in. drill bit
- Hammer
- Center punch

1. *For Heavy Duty Xtreme Sprayers (Series A and B):* Modify cart.
  - a. Loosen mounting bolts and remove the pump assembly from the cart. See the sprayer manual for instructions.
  - b. Cut the hose rack so that it is flush with the front of the mounting plate.

						
To avoid cutting your hand, debur sharp edges after cutting the hose rack.						

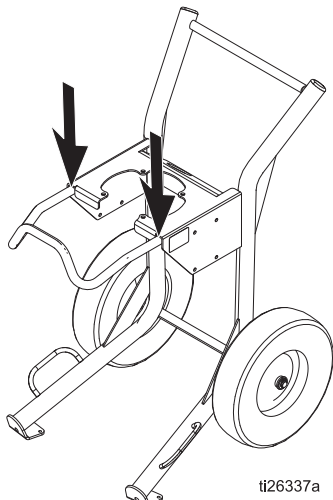

**FIG. 1: Xtreme Sprayer Heavy Duty Cart (Series A and B)**

- c. Modify the front face of the cart as shown to fit the mount plate.

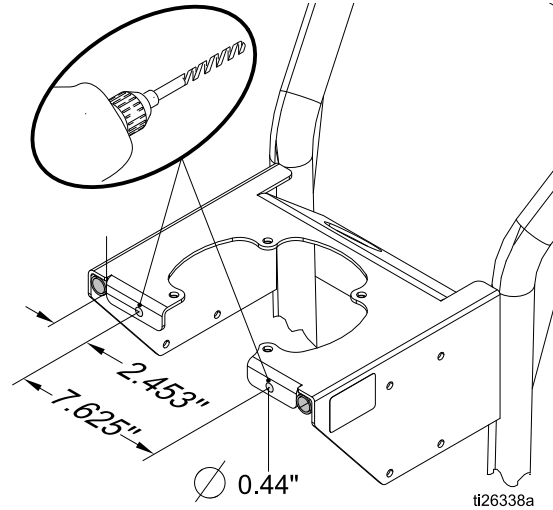

**FIG. 2: Xtreme Sprayer Heavy Duty Cart (Series A and B)**

2. Reassemble pump to cart.
3. Assemble items (4, 5, 6, and 7) with sealant (11).
4. Assemble 60° elbow (12) to pump outlet with sealant (11).
5. Loosely assemble bracket (2) and upper bracket (3) with screws (8) and nuts (9). Once in place, lift bracket (2) to catch handle of hopper (1). Then tighten screws (8) and nuts (9).

# 24Y402

## Parts

Ref. Part	Description	Qty
1	17E114 HOPPER	1
2	17C474 BRACKET	1
3	17G135 BRACKET, upper	1
4	126939 ELBOW, 90°	1
5	128095 CAM/GROOVE	1
6	17C692 FITTING, cam/groove, 1.5 m, 1-1/2 npt	1
7	128094 BUSHING	1
8	112395 SCREW	4
9	112958 NUT	4
10	120781 GASKET	1
11	110110 SEALANT, 6ml	1
12	15M987 ELBOW, 60°	1
13	16U537 LID (not shown)	1
14	17G536 BRACKET, air controls	1
15	240900 AIRLINE	1
16	160327 FITTING, 90°	1
17	105281 FITTING, 45°	1
18	160084 SCREWS	4

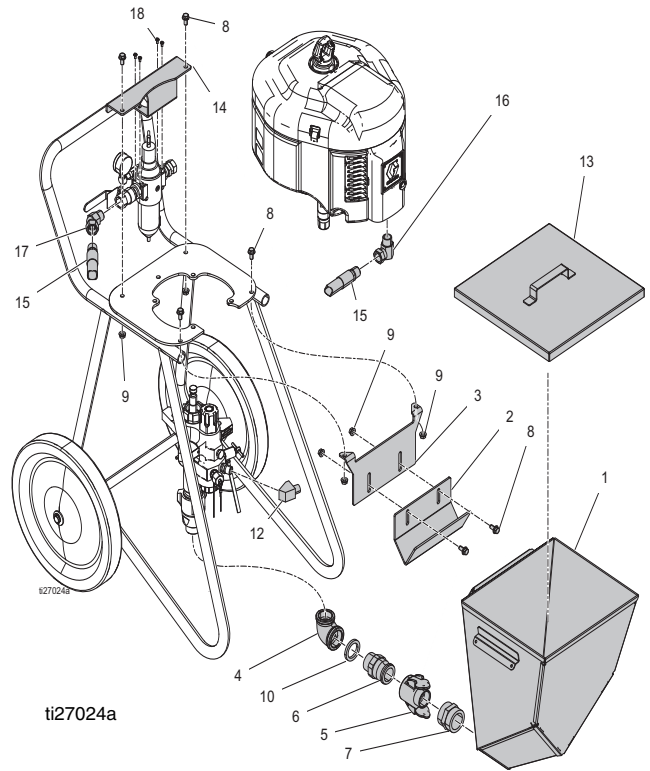



# 24Y402 Installation

## Required Tools

- Reciprocating saw with steel cutting blade (sawzall)
- Drill
- 7/16 in. drill bit
- Hammer
- Center punch

1. *For Lightweight Xtreme Sprayers (Series A and B):* Modify cart.
  - a. Loosen mounting bolts and remove the pump assembly from the cart. See the sprayer manual for instructions.
  - b. Cut the hose rack so that it is flush with the front of the mounting plate.

							
To avoid cutting your hand, debur sharp edges after cutting the hose rack.							

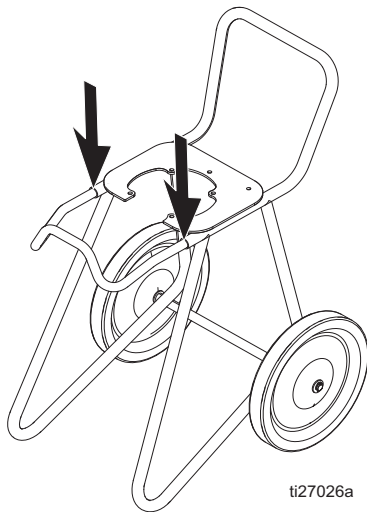

**FIG. 3: Xtreme Sprayer Lightweight Cart (Series A and B)**

- c. Modify the top plate of the cart as shown to fit the mount plate.

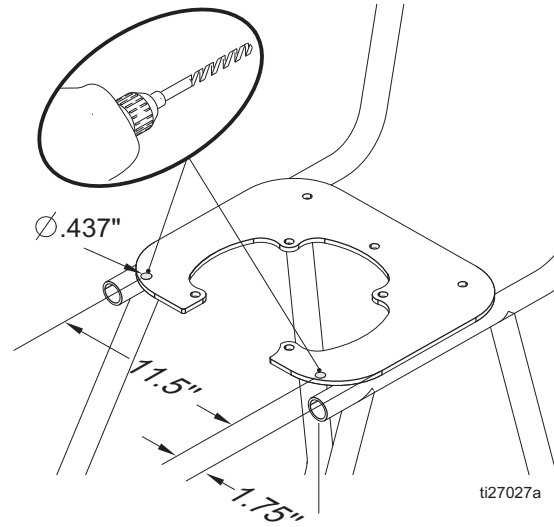

**FIG. 4: Xtreme Sprayer Lightweight Cart (Series A and B)**

- Remove Air Controls (24E025) from Air Motor.

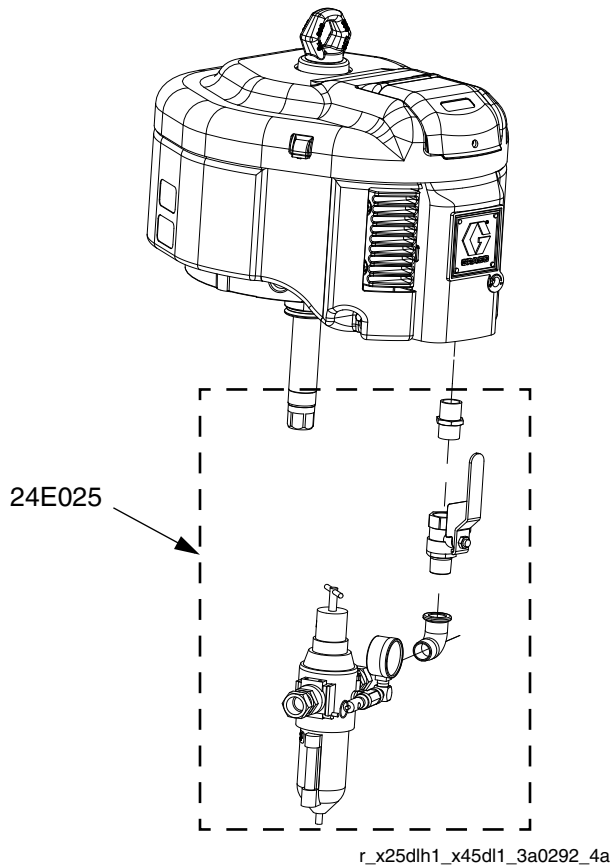

**FIG. 5:**

- Remove Fittings: A, B, C, and D from Air Control Assembly.

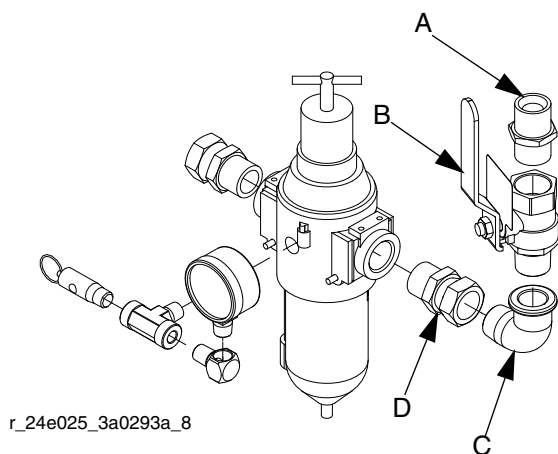

**FIG. 6:**

- Reconfigure Ball Valve (B) as shown, and install 45° elbow (16).

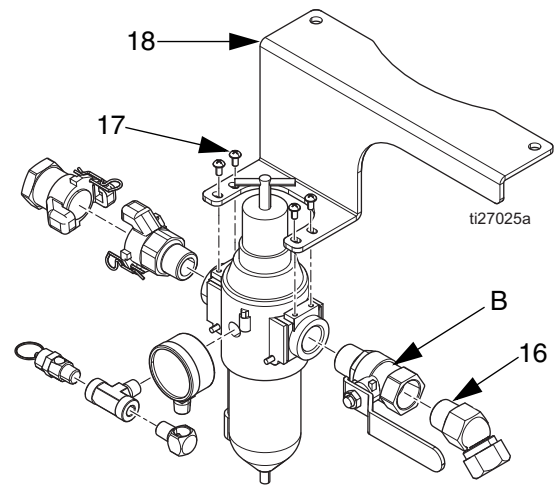

**FIG. 7:**

- Assemble Bracket (18) with screws (17).
- Mount bracket (14) to underside of frame plate using hardware (8, 9).
- Assemble items (4, 5, 6, 7) with sealant (11).
- Assemble 90° elbow fitting (16) to Air Motor with sealant (11).
- Assemble Air Line (15) to Air Controls and elbow.
- Assemble 60° elbow (12) to pump outlet with sealant (11).
- Loosely assemble bracket (2) with fasteners (8, 9). Once in place, lift bracket (3) to catch handle of hopper (1). Torque fasteners to secure in place.

# Graco Standard Warranty

Graco warrants all equipment referenced in this document which is manufactured by Graco and bearing its name to be free from defects in material and workmanship on the date of sale to the original purchaser for use. With the exception of any special, extended, or limited warranty published by Graco, Graco will, for a period of twelve months from the date of sale, repair or replace any part of the equipment determined by Graco to be defective. This warranty applies only when the equipment is installed, operated and maintained in accordance with Graco's written recommendations.

This warranty does not cover, and Graco shall not be liable for general wear and tear, or any malfunction, damage or wear caused by faulty installation, misapplication, abrasion, corrosion, inadequate or improper maintenance, negligence, accident, tampering, or substitution of non-Graco component parts. Nor shall Graco be liable for malfunction, damage or wear caused by the incompatibility of Graco equipment with structures, accessories, equipment or materials not supplied by Graco, or the improper design, manufacture, installation, operation or maintenance of structures, accessories, equipment or materials not supplied by Graco.

This warranty is conditioned upon the prepaid return of the equipment claimed to be defective to an authorized Graco distributor for verification of the claimed defect. If the claimed defect is verified, Graco will repair or replace free of charge any defective parts. The equipment will be returned to the original purchaser transportation prepaid. If inspection of the equipment does not disclose any defect in material or workmanship, repairs will be made at a reasonable charge, which charges may include the costs of parts, labor, and transportation.

**THIS WARRANTY IS EXCLUSIVE, AND IS IN LIEU OF ANY OTHER WARRANTIES, EXPRESS OR IMPLIED, INCLUDING BUT NOT LIMITED TO WARRANTY OF MERCHANTABILITY OR WARRANTY OF FITNESS FOR A PARTICULAR PURPOSE.**

Graco's sole obligation and buyer's sole remedy for any breach of warranty shall be as set forth above. The buyer agrees that no other remedy (including, but not limited to, incidental or consequential damages for lost profits, lost sales, injury to person or property, or any other incidental or consequential loss) shall be available. Any action for breach of warranty must be brought within two (2) years of the date of sale.

**GRACO MAKES NO WARRANTY, AND DISCLAIMS ALL IMPLIED WARRANTIES OF MERCHANTABILITY AND FITNESS FOR A PARTICULAR PURPOSE, IN CONNECTION WITH ACCESSORIES, EQUIPMENT, MATERIALS OR COMPONENTS SOLD BUT NOT MANUFACTURED BY GRACO.** These items sold, but not manufactured by Graco (such as electric motors, switches, hose, etc.), are subject to the warranty, if any, of their manufacturer. Graco will provide purchaser with reasonable assistance in making any claim for breach of these warranties.

In no event will Graco be liable for indirect, incidental, special or consequential damages resulting from Graco supplying equipment hereunder, or the furnishing, performance, or use of any products or other goods sold hereto, whether due to a breach of contract, breach of warranty, the negligence of Graco, or otherwise.

## **FOR GRACO CANADA CUSTOMERS**

The Parties acknowledge that they have required that the present document, as well as all documents, notices and legal proceedings entered into, given or instituted pursuant hereto or relating directly or indirectly hereto, be drawn up in English. Les parties reconnaissent avoir convenu que la rédaction du présente document sera en Anglais, ainsi que tous documents, avis et procédures judiciaires exécutés, donnés ou intentés, à la suite de ou en rapport, directement ou indirectement, avec les procédures concernées.

# Graco Information

For the latest information about Graco products, visit [www.graco.com](http://www.graco.com).

For patent information, see [www.graco.com/patents](http://www.graco.com/patents).

**TO PLACE AN ORDER, contact your Graco distributor or call to identify the nearest distributor.**

**Phone: 612-623-6921 or Toll Free: 1-800-328-0211 Fax: 612-378-3505**

*All written and visual data contained in this document reflects the latest product information available at the time of publication. Graco reserves the right to make changes at any time without notice.*

Original instructions. This manual contains English. MM 333507

**Graco Headquarters:** Minneapolis

**International Offices:** Belgium, China, Japan, Korea

**GRACO INC. AND SUBSIDIARIES • P.O. BOX 1441 • MINNEAPOLIS MN 55440-1441 • USA**

**Copyright 2015, Graco Inc. All Graco manufacturing locations are registered to ISO 9001.**

[www.graco.com](http://www.graco.com)

Revision C, March 2018