

Dyna-Star[®] HP Pump System

3A3957A

EN

Provides lubricant flow and pressure to operate a single line parallel automatic lubrication system. For automatic lubrication systems only.

Not approved for use in European explosive atmosphere locations.

Models:

77X204 - 60 lb

77X205 - 90 lb

24VDC, Injector module with pump, tube-in-tube, vent valve, low level, 60 lb. or 90 lb. reservoir.

3500 psi (24.1 MPa, 241 bar) Maximum Working Pressure



Important Safety Instructions

Read all warnings and instructions in this manual, the Dyna-Star HP and HF Pump instruction manual and all related component manuals (listed below). Save all instructions.

Related Manuals

Manual	Description
332514	Dyna-Star HP and HF Pump
332519	Dyna-Star HP Vent Valve Kit
333499	Cable Harness Kit
3A2960	GLC2200 Lubrication Controller
334998	Power Cable Kit

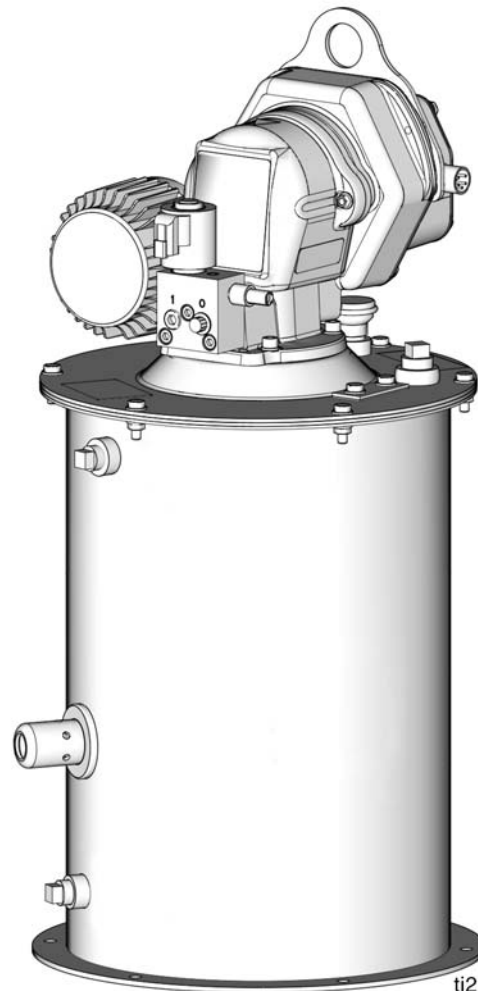









ti27360a









Warnings

The following warnings are for the setup, use, grounding, maintenance, and repair of this equipment. The exclamation point symbol alerts you to a general warning and the hazard symbols refer to procedure-specific risks. When these symbols appear in the body of this manual or on warning labels, refer back to these Warnings. Product-specific hazard symbols and warnings not covered in this section may appear throughout the body of this manual where applicable.

 <h1 style="margin: 0;">WARNING</h1>	
 	<p>FIRE AND EXPLOSION HAZARD</p> <p>When flammable fluids are present in the work area, such as gasoline and windshield wiper fluid, be aware that flammable fumes can ignite or explode. To help prevent fire and explosion:</p> <ul style="list-style-type: none"> • Use equipment only in well ventilated area. • Eliminate all ignition sources, such as cigarettes and portable electric lamps. • Ground all equipment in the work area. • Keep work area free of debris, including rags and spilled or open containers of solvent and gasoline. • Do not plug or unplug power cords or turn lights on or off when flammable fumes are present. • Use only grounded hoses. • Stop operation immediately if static sparking occurs or you feel a shock. Do not use equipment until you identify and correct the problem. • Keep a working fire extinguisher in the work area.
    	<p>SKIN INJECTION HAZARD</p> <p>High-pressure fluid from dispensing device, hose leaks, or ruptured components will pierce skin. This may look like just a cut, but it is a serious injury that can result in amputation. Get immediate surgical treatment.</p> <ul style="list-style-type: none"> • Do not point dispensing device at anyone or at any part of the body. • Do not put your hand over the fluid outlet. • Do not stop or deflect leaks with your hand, body, glove, or rag. • Follow the Pressure Relief Procedure when you stop dispensing and before cleaning, checking, or servicing equipment. • Tighten all fluid connections before operating the equipment. • Check hoses and couplings daily. Replace worn or damaged parts immediately.

WARNING

 	<p>EQUIPMENT MISUSE HAZARD</p> <p>Misuse can cause death or serious injury.</p> <ul style="list-style-type: none"> • Do not operate the unit when fatigued or under the influence of drugs or alcohol. • Do not exceed the maximum working pressure or temperature rating of the lowest rated system component. See Technical Data in all equipment manuals. • Use fluids and solvents that are compatible with equipment wetted parts. See Technical Data in all equipment manuals. Read fluid and solvent manufacturer's warnings. For complete information about your material, request Safety Data Sheet (SDS) from distributor or retailer. • Turn off all equipment and follow the Pressure Relief Procedure when equipment is not in use. • Check equipment daily. Repair or replace worn or damaged parts immediately with genuine manufacturer's replacement parts only. • Do not alter or modify equipment. Alterations or modifications may void agency approvals and create safety hazards. • Make sure all equipment is rated and approved for the environment in which you are using it. • Use equipment only for its intended purpose. Call your distributor for information. • Route hoses and cables away from traffic areas, sharp edges, moving parts, and hot surfaces. • Do not kink or over bend hoses or use hoses to pull equipment. • Keep children and animals away from work area. • Comply with all applicable safety regulations.
 	<p>MOVING PARTS HAZARD</p> <p>Moving parts can pinch, cut or amputate fingers and other body parts.</p> <ul style="list-style-type: none"> • Keep clear of moving parts. • Do not operate equipment with protective guards or covers removed. • Pressurized equipment can start without warning. Before checking, moving, or servicing equipment, follow the Pressure Relief Procedure and disconnect all power sources.
	<p>BURN HAZARD</p> <p>Equipment surfaces and fluid that is heated can become very hot during operation. To avoid severe burns:</p> <ul style="list-style-type: none"> • Do not touch hot fluid or equipment.
 	<p>PERSONAL PROTECTIVE EQUIPMENT</p> <p>Wear appropriate protective equipment when in the work area to help prevent serious injury, including eye injury, hearing loss, inhalation of toxic fumes, and burns. Protective equipment includes but is not limited to:</p> <ul style="list-style-type: none"> • Protective eyewear, and hearing protection. • Respirators, protective clothing, and gloves as recommended by the fluid and solvent manufacturer.

Typical Installation: Injector System

The installation shown in below is only a guide for selecting and installing system components. Contact your Graco distributor for assistance in planning a system to suit your needs.

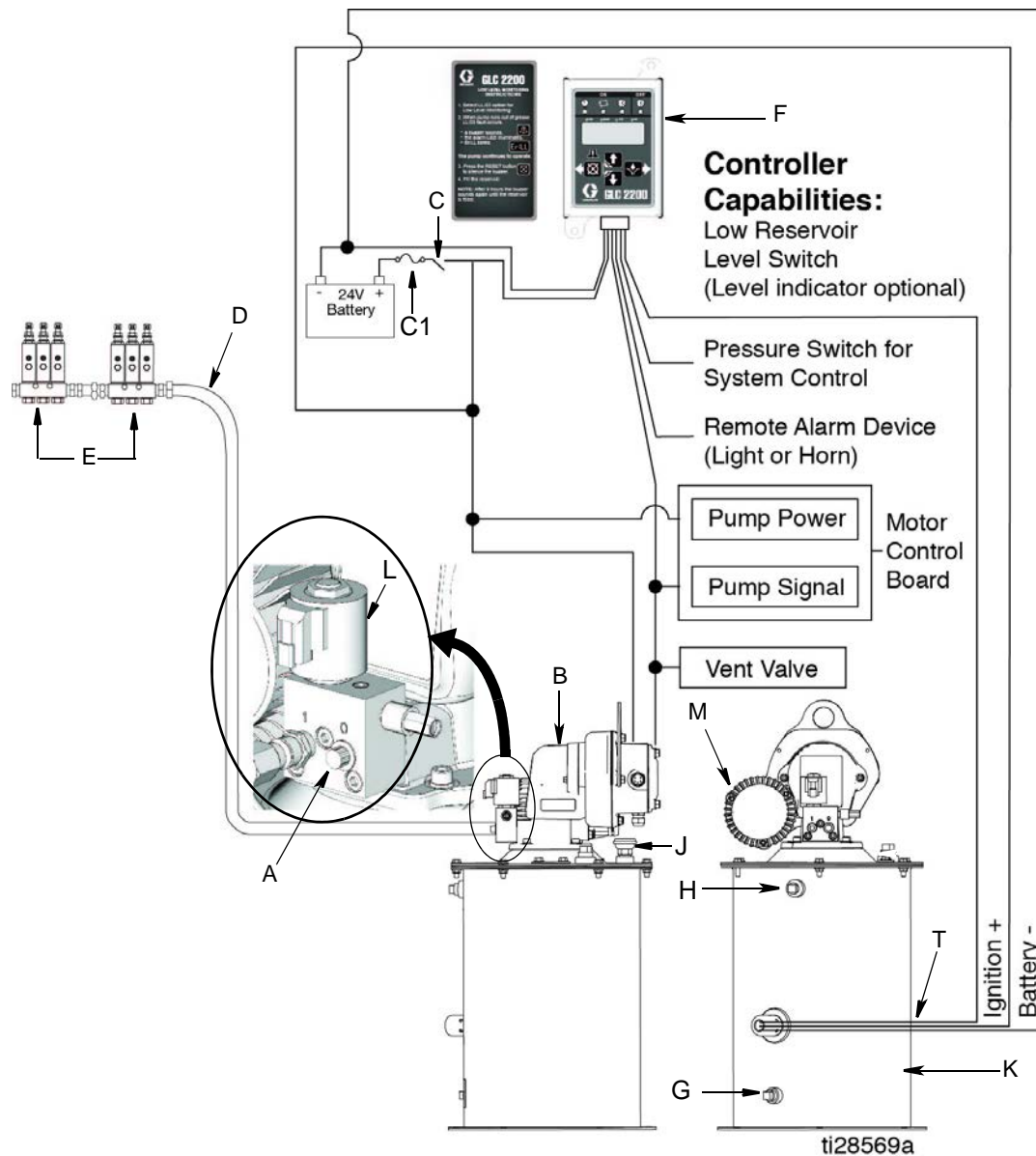

FIG. 1

Key:

- | | |
|--|--------------------|
| A Lubricant outlet connection (marked with an "0") | H Overflow port |
| B Pump | J Breather |
| C Ignition switch | K Reservoir |
| C1 Fuse | L Vent Valve |
| D Lubricant supply lines | M Motor |
| E Injector banks | T Low Level Sensor |
| F Lubrication controller | |
| G Fill port | |

Installation

Pressure Relief Procedure



Follow the Pressure Relief Procedure whenever you see this symbol.



This equipment stays pressurized until pressure is manually relieved. To help prevent serious injury from pressurized fluid, such as skin injection, splashing fluid and moving parts, follow the Pressure Relief Procedure when you stop dispensing and before cleaning, checking, or servicing the equipment.

To relieve pressure in the system, use two wrenches working in opposite directions on pump outlet fitting to **slowly loosen fitting only** until fitting is loose and no more lubricant or air is leaking from fitting as shown in FIG. 2.

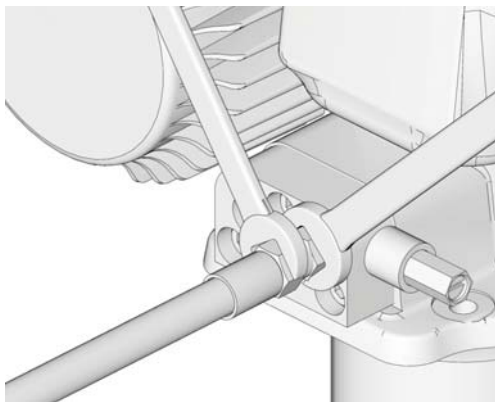

FIG. 2

Grounding



The equipment must be grounded to reduce the risk of static sparking. Static sparking can cause fumes to ignite or explode. Grounding provides an escape wire for the electrical current.

System Configuration and Wiring

NOTE: Cable wiring harness kits are available from Graco. See Parts page 14 for a complete list of available kits.

Fuses

NOTICE
<p>Fuses (user supplied) are required on all models. To avoid equipment damage:</p> <ul style="list-style-type: none"> • Never operate the Dyna-Star Pump models without a fuse installed. • A fuse of the correct voltage and amperage must be installed in line with the power entry to the system. Graco recommends using 35A fuses.

NOTE: The pump is equipped with a 6-pin (4 pins are used), M23 connector for use with Graco cable wiring harness kits 77X546. See Parts page 14.

FIG. 3 shows the pump connections when used with Graco Wire Harness 77X546. Also see pages 7 and 8 for connection details when a customer/user supplied wiring harness is used.

Pump Connection with Graco Wiring Harness 77X546

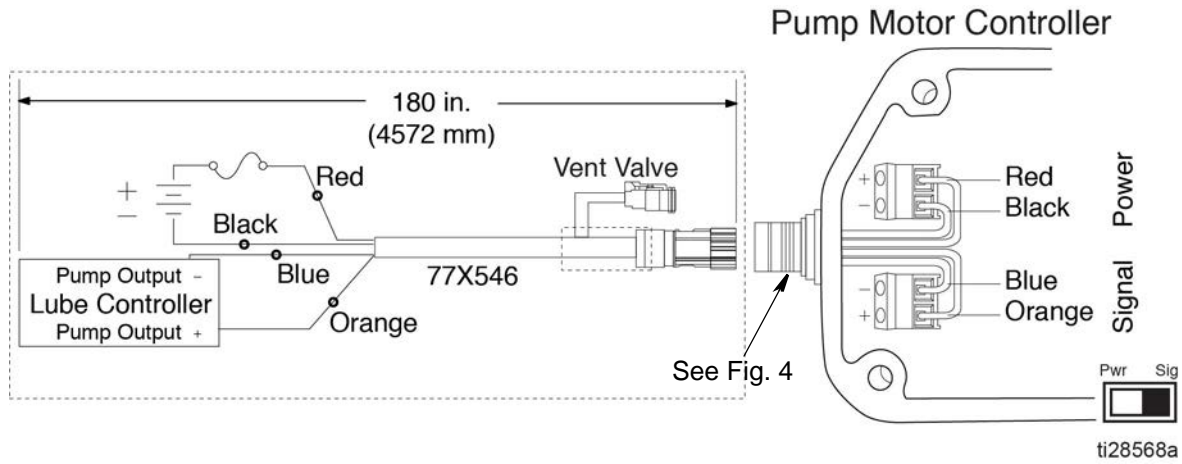

FIG. 3

Wire Connection Table

Pin	Wire Color	Connection
1	Orange	Signal +
2	Black	Power -
4	Red	Power +
5	Blue	Signal -

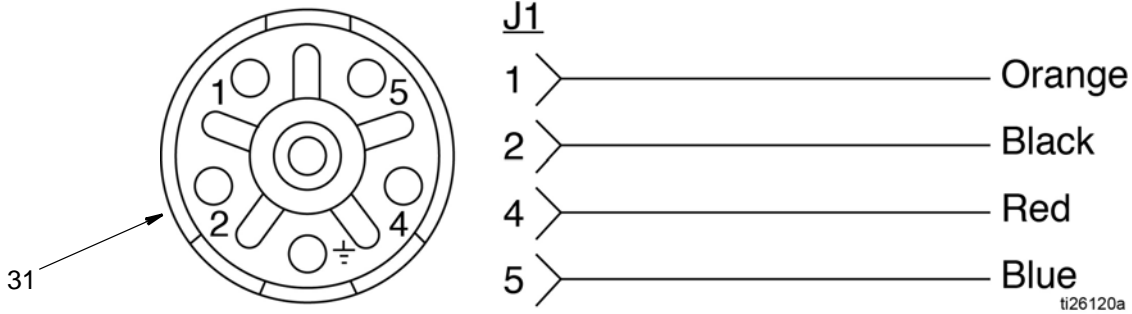

FIG. 4

User Supplied Wiring Harness

24 VDC With Signal Input

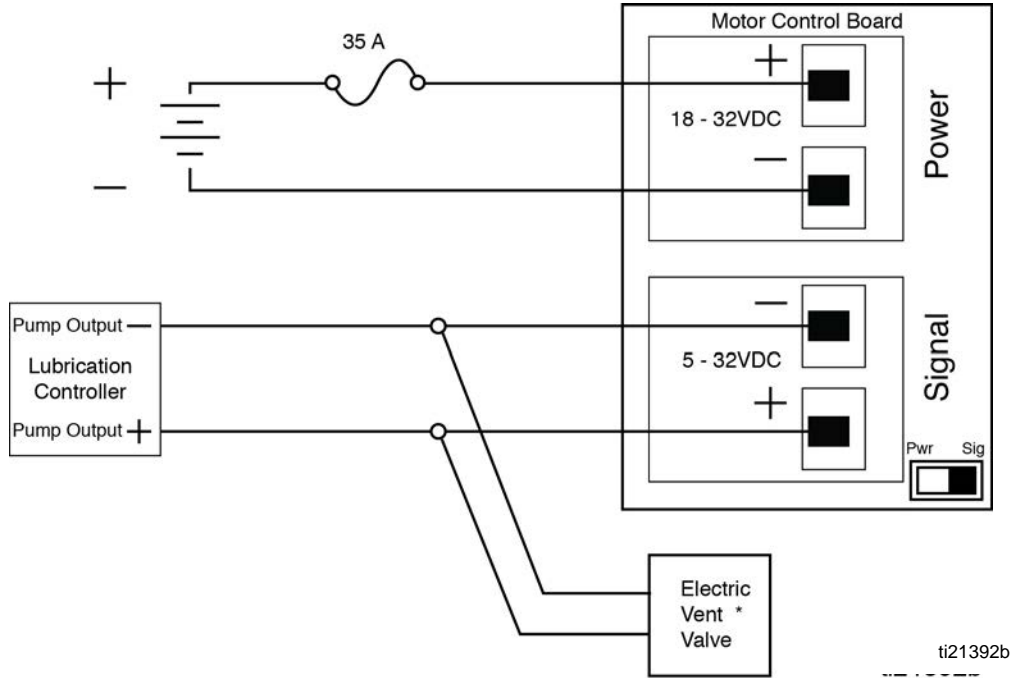

FIG. 5: Pump control switch shown in signal mode

**A Vent Valve is only used in an injector-based system.*

24 VDC With External Relay

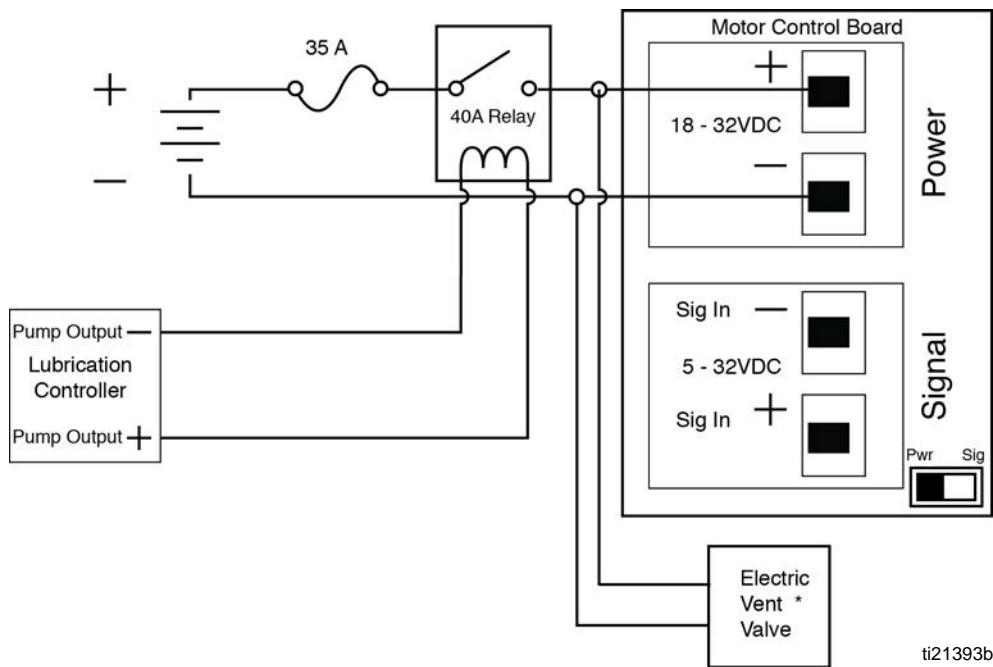

FIG. 6: Pump controls switch shown in power mode

**A Vent Valve is only used in an injector-based system.*

Motor Control Board

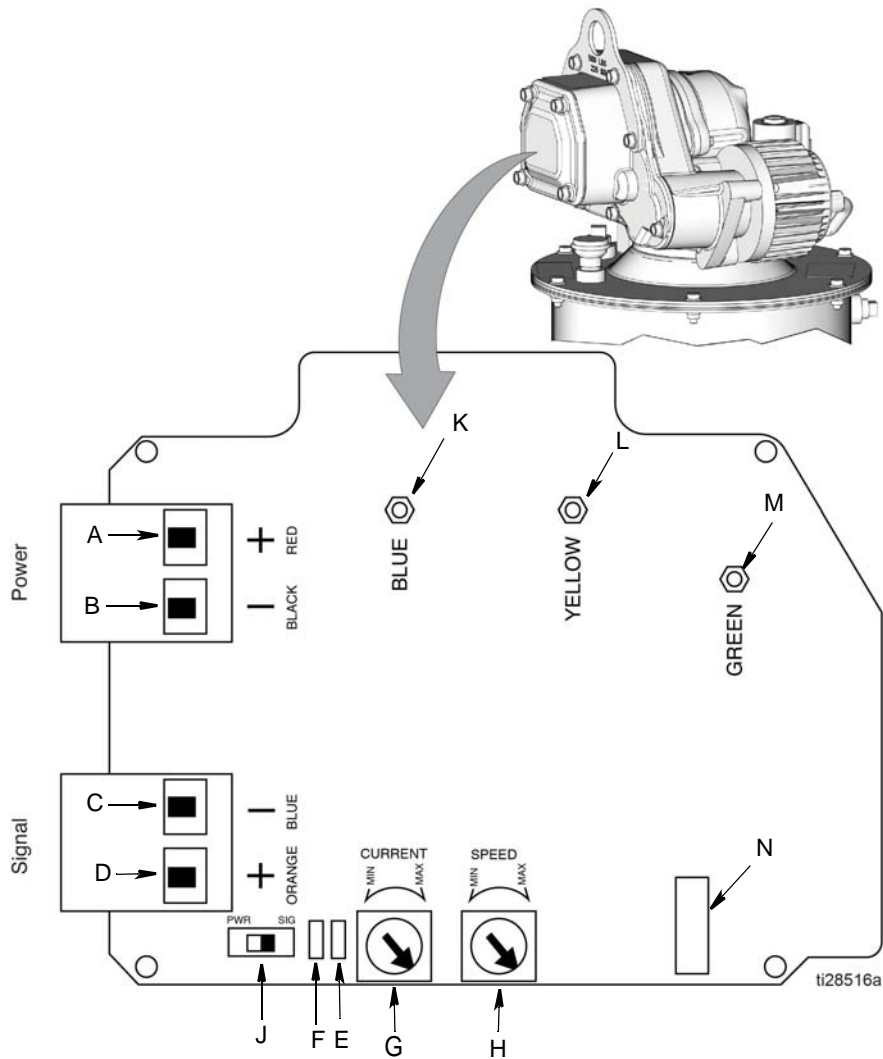

FIG. 7

Key

- A + (Positive) Power Input
- B - (Negative) Power Input
- C Turn On Signal -
- D Turn On Signal +
- E Red (Fault) LED - Blinks type of fault (See Fault Table)
- F Green (Power) LED -
 - Blinks: Power ON, Pump running
 - Solid: Power/Pump OFF
- G Current Control Potentiometer (Minimum: Turn Knob Counter-Clockwise / Maximum: Turn Knob Clockwise)
- H Flow Control Potentiometer (Minimum: Turn Knob Counter-Clockwise / Maximum: Turn Knob Clockwise)
- J Pump Control Switch*
 - PWR - Turns pump on when power is applied

- SIG - Turns pump on when voltage is applied to:
 - SIG IN -
 - SIG IN +
 - K Blue Motor Wire Connection
 - L Yellow Motor Wire Connection
 - M Green Motor Wire Connection
 - N J5 Connector - Motor Hall Cable Connector
- *NOTE:** Be sure power to pump is OFF before switching between the PWR and SIG modes.

Fault Table: Red LED (E)

Fault	Blinks
Over Current	1
Locked Rotor	2
Low or High Voltage	3
High Motor temp	4
Missing Temp Sensor	5
High Board Temp	6
Bad Hall Cable	7

Pump Control Operation

NOTICE

To avoid equipment damage, remove power before switching modes from signal to power or power to signal.

- When the pump control switch (J, FIG. 7, page 8) is set in signal mode, the motor/pump runs when voltage is applied to the signal and power connectors.
- When the pump control switch (J, FIG. 7, page 8) is set in power mode, the motor/pump runs when voltage is applied to the power connectors. The signal connectors do not require voltage.

Current Control and Flow Motor Control Settings

Current and Flow Control Adjustment

1. Remove screws (a), cover (b) and gasket (c) to access the control board (FIG. 8).

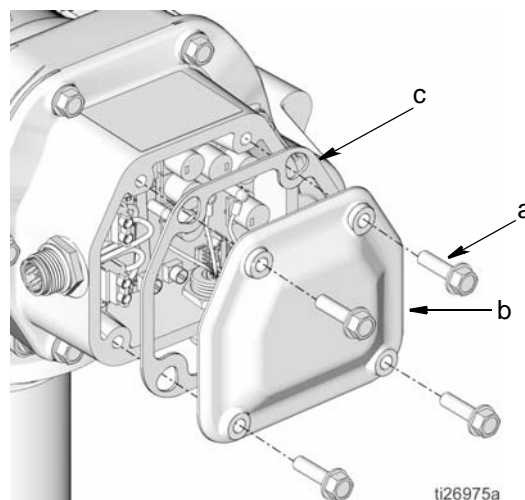
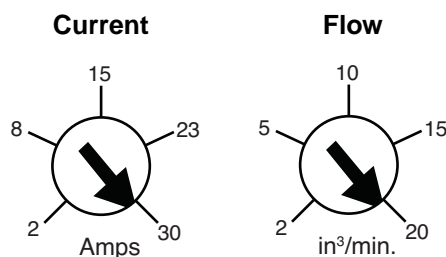

FIG. 8

2. Current and Flow control are adjusted on the Motor Control Board using the Current Control Potentiometer Knob (G) and the Flow Control Potentiometer Knob (H) (page 8). The Current Control knob (G) governs pump speed, which in turn governs flow. The Current setting has precedence over the Flow Rate setting. You may be limited in achievable Flow Rate by the Current setting.

Turn knob clockwise to increase setting value.

- Turn knob counter-clockwise to decrease setting value.



NOTE: Values are based on lab test conditions at ambient temperature 72°F (22°C) with an input voltage of 24V. Actual results may vary and should be verified in the application.

3. Replace gasket (c) and cover (b) and screws (a), being careful not to pinch any wires. Tighten bolts securely. Torque bolts to 17-19 ft.-lbs (23-26 N.m).

Reservoir Installation

				
<p>LIFTING HAZARD This equipment is heavy. Lifting or moving heavy equipment incorrectly can cause serious injury such as muscle strain or back injuries. To avoid injury:</p> <ul style="list-style-type: none"> • Do not lift or move this equipment without assistance. • Always use a lifting device secured to the pump lift ring when moving or installing this equipment. See Technical Data, page 15 for pump weight. 				

1. Mount Reservoir (H) on sturdy, flat surface with 6 (six) 3/8 inch diameter bolts. Note location of Low Level (L) and Lubricant Outlet Connection (A) for easy access once installed.
2. Connect High Pressure Lubricant Supply Line (D) to the Lubricant Outlet Connection (A).
3. Ground system (see **Grounding**). Mount reservoir to grounded chassis member.

Pump (B)

Pump instructions are provided in the Dyna-Star HP or HF Pump instruction manual 332514 provided with your system.

Pump Module Operation





The pump module provides lubricant flow and pressure to operate a single line parallel automatic lubrication system.

The module requires an electrical power supply and a timed signal from a lubrication controller (F). Based on these signals, the pump module provides lubricant flow and pressure to operate the injectors (E) and vents the injector system to reset the indicators.

1. At the start of the cycle, the lubrication controller (F) initiates a signal, closing the vent valve (L) and starting the pump (B).
2. The pump (B) builds pressure in supply line (D) until all the injectors have actuated. Then the pressure switch sends a signal to the lubrication controller (F), ending the cycle.

3. The lubrication controller (F) terminates the signal to the pump (B) and power to the vent valve (L).
4. The vent valve (L) opens.
5. Pressure in the supply line (D) is relieved back into the reservoir, resetting all injectors (E).

Inlet and Outlet Components

				
<p>COMPONENT RUPTURE HAZARD The maximum working pressure of the inlet and outlet components in the system vary. Over-pressurizing an inlet or outlet can cause it to rupture resulting in property damage and serious injury such as skin injection or injury from splashing fluid. To reduce the risk of component rupture:</p> <ul style="list-style-type: none"> • Be sure to know the maximum working pressure of each inlet and outlet component in the system. • Never exceed the maximum working pressure of the inlet and outlet components. 				

Vent Valve (L)

The vent valve is used to reduce system pressure and allow the injector to reset. When energized, grease is pumped out through the outlet port (marked 0) on the vent valve. When de-energized, it vents pressure internally to tank.

Refer to the Dyna-Star HP or HF Vent Valve Kit manual 332519 for installation and operation instructions.

Low Level Sensor (T)

When grease is present the LED is green. When the lubricant level in the reservoir reaches approximately 30% (low level), the LED turns to an amber color. (FIG. 9 and the Table below).

Condition	LED COLOR	Out 2 (Pin #2) (See FIG. 10)
Grease Present	Green	0 VDC
No Grease Present	Amber	24 VDC

NOTE:

- At 30% capacity, the amber low level signals the tank is reaching a point where the operator should refill the tank. There is still lubricant in the tank and immediate shutdown is not required.
- If you are using a GLC2200 (part number 24N468, Series F or later only), the system will enter a low level warning condition (LL03) after the switch input is closed for more than 1 second. The pump continues to operate.

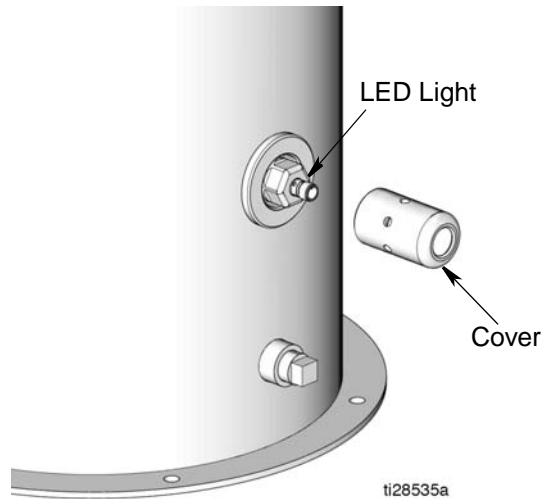

FIG. 9

Keep the sensor protective cover (11b, page 14) installed to prevent sensor damage.

Low Level Sensor Wiring instructions are provided below.

NOTE: Graco GLC2200 (part number 24N468, Series F or later only) can be used to run the pump and monitor the low level. Refer to FIG. 10 for Low Level Sensor wiring in systems controlled with a GLC2200. A Low Level Sensor cable (part number 129072) and a GLC2200 Wiring Harness (part number 24P314) are required.

Low Level Sensor Wiring with GLC2200 Lube Controller

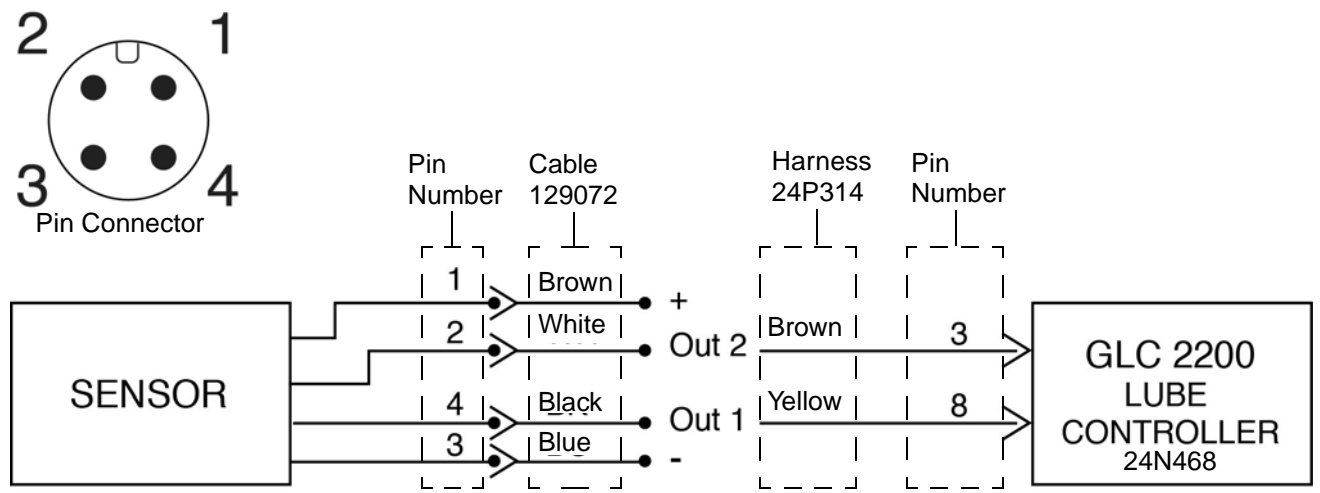

ti27370a

FIG. 10: Sensor

Refilling the Reservoir

Filling Reservoir With Fill Port (G)

NOTICE

To prevent damage to the unit:

- Check Breather vent (J) for proper operation before filling reservoir.
- Open Overflow Port (H) before filling for visual inspection of lubricant level.
- Do not fill beyond Overflow Port (H).
- Do not use Overflow Port (H) to fill reservoir.

1. Connect lubricant supply hose to Fill Port (G).
2. Remove plug from Overflow Port (H).
3. Slowly fill reservoir until level of lubricant reaches Overflow Port (H).
4. Disconnect lubricants supply hose from Fill Port (G).
5. Plug Fill Port (G) and Overflow Port (H).

NOTICE

Never allow pump to run dry of the fluid being pumped. Running a pump dry can damage the pump.

Service

Use only Genuine Graco Repair Parts.

See separate system component manuals for service instructions. For pump service see manual 332514. For vent valve service see manual 332519.

Troubleshooting



Problem	Cause	Solution
Pump (B) is not running; i.e., not cycling, there is no lubricant output, pump runs slow, the control board's red LED fault is illuminated, etc.	Pump (B) malfunction.	Refer to pump manual 332514.
Lubricant is leaking from pressure relief.	Blockage in line.	Check for blockage in the line. Clear blockage.
	Pressure switch not actuated/malfunctioning.	Check switch wiring Replace pressure switch
	Pressure switch set too high.	Reduce system pressure
Low level alarm did not come on but pump cavitates (runs out of grease). or Pressure is not building in the system and a "no pressure" error is initiated	Low level sensor malfunction	Check sensor LED. If green, tank has grease but pump is not able to pump grease. See Troubleshooting instructions in pump manual 332514.
		Check sensor LED. If amber, tank has no grease, check wiring between sensor and alarm.
		Check sensor LED. If there is no light, check sensor wiring to verify there is power to the sensor.
	Pressure switch malfunction	Check pressure switch wiring
	Low pressure or no pressure in the system	Check piping for leaks. If a leak is detected, repair or replace piping. Check injectors for leaks. If a leak is detected repair or replace injectors.
Low level alarm is activated and continuous but the reservoir is filled with grease	Low level sensor malfunction	Check sensor wiring.

Parts List

Ref. No.	Part No.	Description	Qty
1	77X011	KIT, pump and vent valve, 60#, includes 1a and 1b	1
	77X012	KIT, pump and vent valve, 90#, includes 1a and 1b	1
1a		PUMP, Dyna-Star, see instruction manual 332514	1
1b		VENT VALVE, see instruction manual 332519	1
3		KIT, reservoir, grease, includes 3a-3n	1
3a	100737	. PLUG, pipe	2
3c		. NUT, flanged, hex	8
3d		. SCREW, cap, flange head	8
3e		. BREATHER	1
3f	194868	. GASKET, cover	1
3g		. PAIL, reservoir	1
3h	16V394	. COVER, reservoir	1
3j	109114	. SCREW, cap	4
3k	15M442	. GASKET, pump	1
3l	104572	. WASHER, lock, spring	4
3m	16V396	. SEAL	1
3n	16V395	. COVER	1
8▲	195341	LABEL, notice, breather	1
9▲	16U728	LABEL, over pressurize warning	1
10▲	15H108	LABEL, pinch warning	1
11		LOW LEVEL	
11a	17L372	SWITCH, low level (includes 11c)	1
11b		COVER, low level	1
11c		O-RING	

▲ Replacement Danger and Warning labels, tags and cards are available at no cost.

Accessories

Part No.	Description
24N468	GLC2200 Lube Controller (Series F or later only)

Cable Harness Kits

129072	CABLE, low level
77X546	CABLE, power, straight, 15 feet, with vent valve. Use with 77X551
24N402	CABLE, 6 ft, vent valve, 2 pin for vent valve control
24P314	CABLE, GLC2200 Wiring Harness

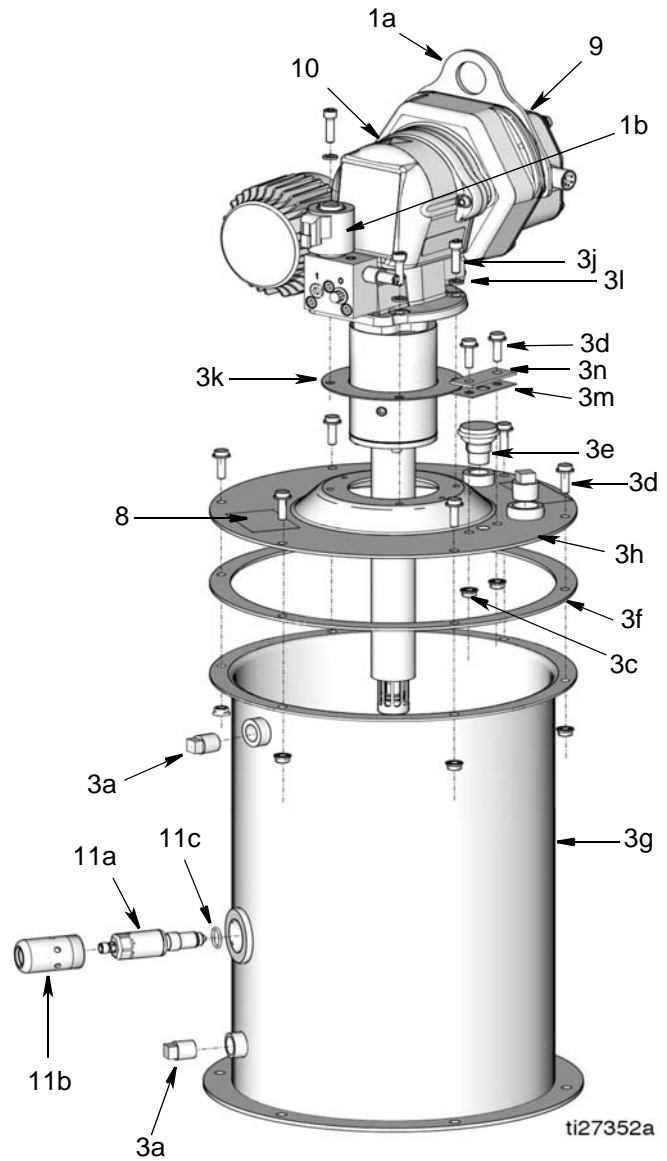

Technical Data

Dyna-Star Pump		
	US	Metric
Maximum working pressure	3500 psi	24.1 MPa, 241 bar
Grease capacity	60 lb.	27 kg
	90 lb.	41 kg
Reservoir overflow port size	1/2 inch npt	
Reservoir fill port size	1/2 inch npt	
Lubricant outlet port size	3/8 npt (f)	
Pump electrical requirements	See Dyna-Star HP and HF Pump manual: 332514	
Pump wetted parts	See Dyna-Star HP and HF Pump manual: 332514	
Reservoir wetted parts	steel, buna-n rubber	
Vent valve wetted parts	See Dyna-Star HP and HF Vent Valve Kit manual: 332519	
Sound Data: All pumps	See Dyna-Star HP and HF Pump manual: 332514	
Dry Pump Weight		
Model 77X204 - 60#	105 lbs	48 kg
Model 77X205 - 90#	115 lbs	52 kg
Low Level Sensor		
Operating Voltage	24 VDC	
Sensor Current Consumption	<50 mA	
Protection	IP69K	
Connector	M12 connector	
Housing Materials	stainless steel, PEEK; PEI, FKM	
Wetted parts	PEEK	

Dimensions

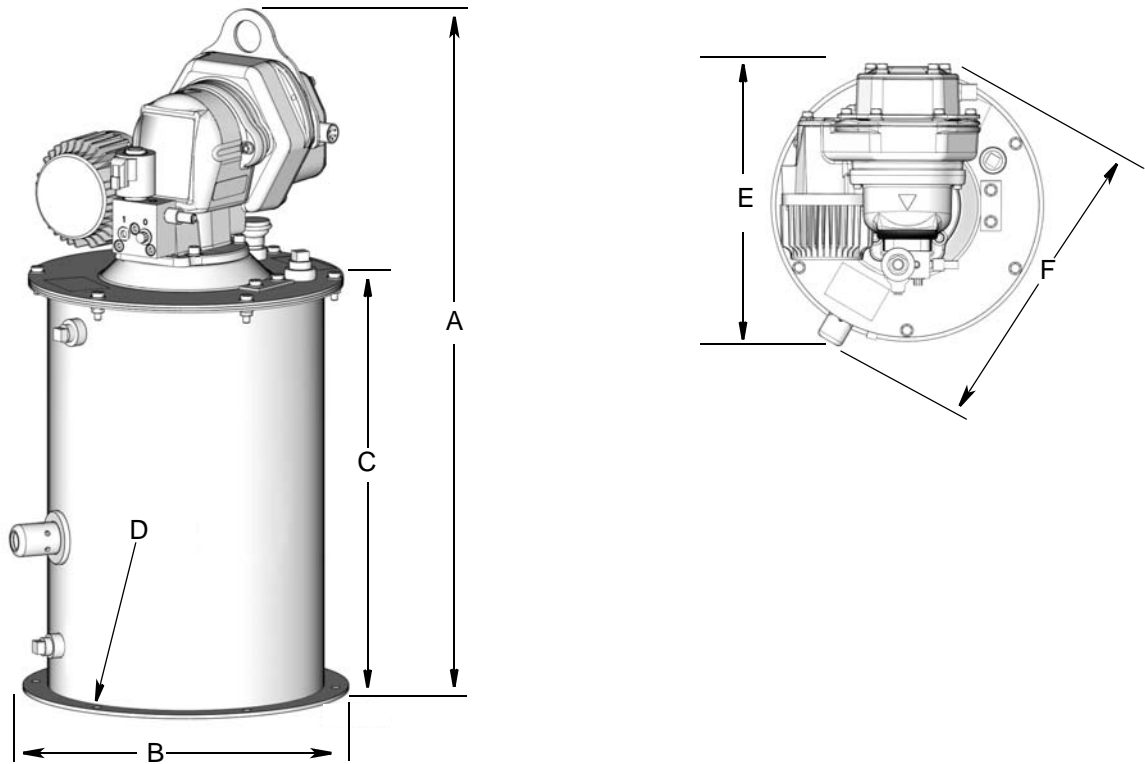

Ref	60 lb Models		90 lb Models	
	US (inch)	Metric (cm)	US (inch)	Metric (cm)
A	30.5	77.47	38.0	96.52
B	14.5	36.83	14.5	36.83
C	19.4	49.28	27.0	68.6
D	7/16 inch Ø hole - 6; 13-7/8 inch bolt circle		six, 7/16 inch Ø hole 13 7/8 inch bolt circle	
E	14.5	36.83	14.5	36.83
F	16.13	40.97	16.13	40.97

Graco Standard Warranty

Graco warrants all equipment referenced in this document which is manufactured by Graco and bearing its name to be free from defects in material and workmanship on the date of sale to the original purchaser for use. With the exception of any special, extended, or limited warranty published by Graco, Graco will, for a period of twelve months from the date of sale, repair or replace any part of the equipment determined by Graco to be defective. This warranty applies only when the equipment is installed, operated and maintained in accordance with Graco's written recommendations.

This warranty does not cover, and Graco shall not be liable for general wear and tear, or any malfunction, damage or wear caused by faulty installation, misapplication, abrasion, corrosion, inadequate or improper maintenance, negligence, accident, tampering, or substitution of non-Graco component parts. Nor shall Graco be liable for malfunction, damage or wear caused by the incompatibility of Graco equipment with structures, accessories, equipment or materials not supplied by Graco, or the improper design, manufacture, installation, operation or maintenance of structures, accessories, equipment or materials not supplied by Graco.

This warranty is conditioned upon the prepaid return of the equipment claimed to be defective to an authorized Graco distributor for verification of the claimed defect. If the claimed defect is verified, Graco will repair or replace free of charge any defective parts. The equipment will be returned to the original purchaser transportation prepaid. If inspection of the equipment does not disclose any defect in material or workmanship, repairs will be made at a reasonable charge, which charges may include the costs of parts, labor, and transportation.

THIS WARRANTY IS EXCLUSIVE, AND IS IN LIEU OF ANY OTHER WARRANTIES, EXPRESS OR IMPLIED, INCLUDING BUT NOT LIMITED TO WARRANTY OF MERCHANTABILITY OR WARRANTY OF FITNESS FOR A PARTICULAR PURPOSE.

Graco's sole obligation and buyer's sole remedy for any breach of warranty shall be as set forth above. The buyer agrees that no other remedy (including, but not limited to, incidental or consequential damages for lost profits, lost sales, injury to person or property, or any other incidental or consequential loss) shall be available. Any action for breach of warranty must be brought within two (2) years of the date of sale.

GRACO MAKES NO WARRANTY, AND DISCLAIMS ALL IMPLIED WARRANTIES OF MERCHANTABILITY AND FITNESS FOR A PARTICULAR PURPOSE, IN CONNECTION WITH ACCESSORIES, EQUIPMENT, MATERIALS OR COMPONENTS SOLD BUT NOT MANUFACTURED BY GRACO. These items sold, but not manufactured by Graco (such as electric motors, switches, hose, etc.), are subject to the warranty, if any, of their manufacturer. Graco will provide purchaser with reasonable assistance in making any claim for breach of these warranties.

In no event will Graco be liable for indirect, incidental, special or consequential damages resulting from Graco supplying equipment hereunder, or the furnishing, performance, or use of any products or other goods sold hereto, whether due to a breach of contract, breach of warranty, the negligence of Graco, or otherwise.

FOR GRACO CANADA CUSTOMERS

The Parties acknowledge that they have required that the present document, as well as all documents, notices and legal proceedings entered into, given or instituted pursuant hereto or relating directly or indirectly hereto, be drawn up in English. Les parties reconnaissent avoir convenu que la rédaction du présente document sera en Anglais, ainsi que tous documents, avis et procédures judiciaires exécutés, donnés ou intentés, à la suite de ou en rapport, directement ou indirectement, avec les procédures concernées.

Graco Information

For the latest information about Graco products, visit www.graco.com.

For patent information, see www.graco.com/patents.

TO PLACE AN ORDER, contact your Graco distributor or call to identify the nearest distributor.

Phone: 612-623-6928 or Toll Free: 1-800-533-9655, Fax: 612-378-3590

*All written and visual data contained in this document reflects the latest product information available at the time of publication.
Graco reserves the right to make changes at any time without notice.*

Original instructions. This manual contains English. MM 3A3957

Graco Headquarters: Minneapolis

International Offices: Belgium, China, Japan, Korea

GRACO INC. AND SUBSIDIARIES • P.O. BOX 1441 • MINNEAPOLIS MN 55440-1441 • USA
Copyright 2016, Graco Inc. All Graco manufacturing locations are registered to ISO 9001.

www.graco.com

Revision A, March 2016