

T3

3A5180L

3:1 Ratio Transfer Pump

EN

For use with polyurethane foam, polyurea, and similar non-flammable materials. For professional use only.

Not approved for use in European explosive atmospheres.

See page 2 for model information.

*100 psi (0.69 MPa, 6.9 bar) Maximum Air Working Pressure
315 psi (2.17 MPa, 21.7 bar) Maximum Fluid Working Pressure*



Important Safety Instructions

Read all warnings and instructions in this manual. Save these instructions.

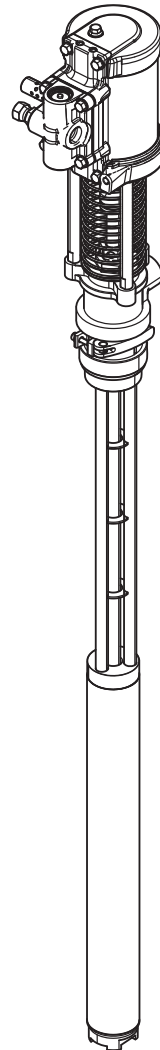

Stainless Steel

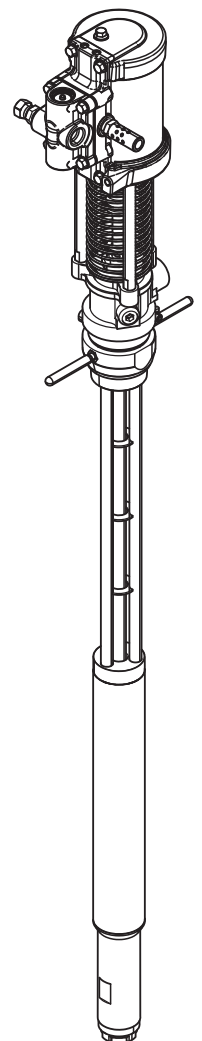

Carbon Steel

ti31038b

Contents





Warnings	3	Operation	15
Important Isocyanate (ISO) Information	5	Pressure Relief Procedure	15
Isocyanate Conditions	5	Flush the Equipment	15
Material Self-Ignition	6	Daily Startup	16
Keep Components A and B Separate	6	Daily Shutdown	16
Moisture Sensitivity of Isocyanates	6	Troubleshooting	17
Foam Resins with 245 fa Blowing Agents	7	Parts	18
Changing Materials	7	Air Motor	18
Typical Installation	8	Air Valve	20
Typical Installation, without Circulation	8	Pump Lower	22
Typical Installation, with Circulation	9	Accessories	28
Typical Installation, with Lubrication	10	Performance Chart	30
Installation	11	Calculate Fluid Outlet Pressure	30
Grounding	11	Calculate Pump Air Consumption	30
Accessories	12	Pressure Conversion Chart	31
Flush Before Using Equipment	12	Standard Cubic Feet/Minute (SCFM) Requirement Chart	31
Setup	13	Dimensions	32
		Technical Specifications	33
		Graco Standard Warranty	34
		Graco Information	34







Models

Part	Series	Pump Ratio	Pump Material	Fluid Supply Accessories		Air Supply Accessories	
				Swivel Fitting (157785)	10 ft Fluid Hose (217382)	Air Supply Kit (246483)	Desiccant Dryer Kit (247616)
24Z987	A	3:1	Stainless steel	✓	✓	✓	✓
24Z988	A	3:1	Stainless steel	✓	✓		
26A304	A	3:1	Stainless steel				
24Z834	B	3:1	Carbon steel				
25D296	B	3:1	Carbon steel	✓	✓		
25D295	B	3:1	Carbon steel	✓	✓	✓	✓

Warnings

The following warnings are for the setup, use, grounding, maintenance, and repair of this equipment. The exclamation point symbol alerts you to a general warning and the hazard symbols refer to procedure-specific risks. When these symbols appear in the body of this manual or on warning labels, refer back to these Warnings. Product-specific hazard symbols and warnings not covered in this section may appear throughout the body of this manual where applicable.

 <h2 style="margin: 0;">WARNING</h2>	
	<p>TOXIC FLUID OR FUMES HAZARD</p> <p>Toxic fluids or fumes can cause serious injury or death if splashed in the eyes or on skin, inhaled or swallowed.</p> <ul style="list-style-type: none"> • Read Safety Data Sheet (SDS) for handling instructions and to know the specific hazards of the fluids you are using, including the effects of long-term exposure. • When spraying, servicing equipment, or when in the work area, always keep work area well ventilated and always wear appropriate personal protective equipment. See Personal Protective Equipment warnings in this manual. • Store hazardous fluid in approved containers, and dispose of it according to applicable guidelines.
	<p>PERSONAL PROTECTIVE EQUIPMENT</p> <p>Always wear appropriate personal protective equipment and cover all skin when spraying, servicing equipment, or when in the work area. Protective equipment helps prevent serious injury, including long-term exposure; inhalation of toxic fumes, mists or vapors; allergic reaction; burns; eye injury and hearing loss. This protective equipment includes but is not limited to:</p> <ul style="list-style-type: none"> • A properly fitting respirator, which may include a supplied-air respirator, chemically impermeable gloves, protective clothing and foot coverings as recommended by the fluid manufacturer and local regulatory authority. • Protective eyewear and hearing protection.
	<p>EQUIPMENT MISUSE HAZARD</p> <p>Misuse can cause death or serious injury.</p> <ul style="list-style-type: none"> • Do not operate the unit when fatigued or under the influence of drugs or alcohol. • Do not exceed the maximum working pressure or temperature rating of the lowest rated system component. See Technical Specifications in all equipment manuals. • Use fluids and solvents that are compatible with equipment wetted parts. See Technical Specifications in all equipment manuals. Read fluid and solvent manufacturer's warnings. For complete information about your material, request Safety Data Sheets (SDSs) from distributor or retailer. • Do not leave the work area while equipment is energized or under pressure. • Turn off all equipment and follow the Pressure Relief Procedure when equipment is not in use. • Check equipment daily. Repair or replace worn or damaged parts immediately with genuine manufacturer's replacement parts only. • Do not alter or modify equipment. Alterations or modifications may void agency approvals and create safety hazards. • Make sure all equipment is rated and approved for the environment in which you are using it. • Use equipment only for its intended purpose. Call your distributor for information. • Route hoses and cables away from traffic areas, sharp edges, moving parts, and hot surfaces. • Do not kink or over bend hoses or use hoses to pull equipment. • Keep children and animals away from work area. • Comply with all applicable safety regulations.

 <h1 style="margin: 0;">WARNING</h1>	
  	<p>PRESSURIZED EQUIPMENT HAZARD</p> <p>Fluid from the equipment, leaks, or ruptured components can splash in the eyes or on skin and cause serious injury.</p> <ul style="list-style-type: none"> • Follow the Pressure Relief Procedure when you stop spraying/dispensing and before cleaning, checking, or servicing equipment. • Tighten all fluid connections before operating the equipment. • Check hoses, tubes, and couplings daily. Replace worn or damaged parts immediately.
	<p>BURN HAZARD</p> <p>Equipment surfaces and fluid that is heated can become very hot during operation. To avoid severe burns:</p> <ul style="list-style-type: none"> • Do not touch hot fluid or equipment.
 	<p>MOVING PARTS HAZARD</p> <p>Moving parts can pinch, cut or amputate fingers and other body parts.</p> <ul style="list-style-type: none"> • Keep clear of moving parts. • Do not operate equipment with protective guards or covers removed. • Pressurized equipment can start without warning. Before checking, moving, or servicing equipment, follow the Pressure Relief Procedure and disconnect all power sources.

Important Isocyanate (ISO) Information

Isocyanates (ISO) are catalysts used in two component materials.

Isocyanate Conditions

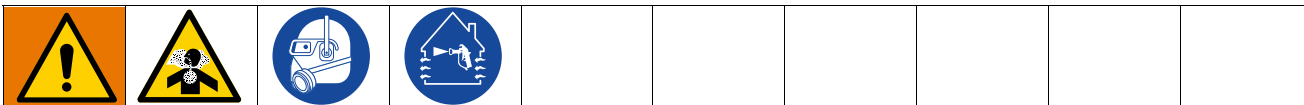

Spraying or dispensing fluids that contain isocyanates creates potentially harmful mists, vapors, and atomized particulates.

- Read and understand the fluid manufacturer’s warnings and Safety Data Sheet (SDS) to know specific hazards and precautions related to isocyanates.
- Use of isocyanates involves potentially hazardous procedures. Do not spray with this equipment unless you are trained, qualified, and have read and understood the information in this manual and in the fluid manufacturer’s application instructions and SDS.
- Use of incorrectly maintained or mis-adjusted equipment may result in improperly cured material which could cause off gassing and offensive odors. Equipment must be carefully maintained and adjusted according to instructions in the manual.
- To prevent inhalation of isocyanate mists, vapors and atomized particulates, everyone in the work area must wear appropriate respiratory protection. Always wear a properly fitting respirator, which may include a supplied-air respirator. Ventilate the work area according to instructions in the fluid manufacturer’s SDS.
- Avoid all skin contact with isocyanates. Everyone in the work area must wear chemically impermeable gloves, protective clothing and foot coverings as recommended by the fluid manufacturer and local regulatory authority. Follow all fluid manufacturer recommendations, including those regarding handling of contaminated clothing. After spraying, wash hands and face before eating or drinking.
- Hazard from exposure to isocyanates continues after spraying. Anyone without appropriate personal protective equipment must stay out of the work area during application and after application for the time period specified by the fluid manufacturer. Generally this time period is at least 24 hours.
- Warn others who may enter work area of hazard from exposure to isocyanates. Follow the recommendations of the fluid manufacturer and local regulatory authority. Posting a placard such as the following outside the work area is recommended:

⚠ WARNING	
	TOXIC FUMES HAZARD
DO NOT ENTER DURING SPRAY FOAM APPLICATION OR FOR ___ HOURS AFTER APPLICATION IS COMPLETE	
DO NOT ENTER UNTIL:	
DATE: _____	
TIME: _____	

Material Self-Ignition



Some materials may become self-igniting if applied too thick. Read material manufacturer's warnings and Safety Data Sheet (SDS).

Keep Components A and B Separate



Cross-contamination can result in cured material in fluid lines which could cause serious injury or damage equipment. To prevent cross-contamination:

- **Never** interchange component A and component B wetted parts.
- Never use solvent on one side if it has been contaminated from the other side.

Moisture Sensitivity of Isocyanates

Exposure to moisture (such as humidity) will cause ISO to partially cure, forming small, hard, abrasive crystal that become suspended in the fluid. Eventually a film will form on the surface and the ISO will begin to gel, increasing in viscosity.

NOTICE

Partially cured ISO will reduce performance and the life of all wetted parts.

- Always use a sealed container with a desiccant dryer in the vent, or a nitrogen atmosphere. **Never** store ISO in an open container.
- Keep the ISO pump wet cup or reservoir (if installed) filled with appropriate lubricant. The lubricant creates a barrier between the ISO and the atmosphere.
- Use only moisture-proof hoses compatible with ISO.
- Never use reclaimed solvents, which may contain moisture. Always keep solvent containers closed when not in use.
- Always lubricate threaded parts with an appropriate lubricant when reassembling.

NOTE: The amount of film formation and rate of crystallization varies depending on the blend of ISO, the humidity, and the temperature.

Foam Resins with 245 fa Blowing Agents

Some foam blowing agents will froth at temperatures above 90°F (33°C) when not under pressure, especially if agitated. To reduce frothing, minimize preheating in a circulation system.

Changing Materials

NOTICE

Changing the material types used in your equipment requires special attention to avoid equipment damage and downtime.

- When changing materials, flush the equipment multiple times to ensure it is thoroughly clean.
- Always clean the fluid inlet strainers after flushing.
- Check with your material manufacturer for chemical compatibility.

When changing between epoxies and urethanes or polyureas, disassemble and clean all fluid components and change hoses. Epoxies often have amines on the B (hardener) side. Polyureas often have amines on the B (resin) side.

Typical Installation

Typical Installation, without Circulation

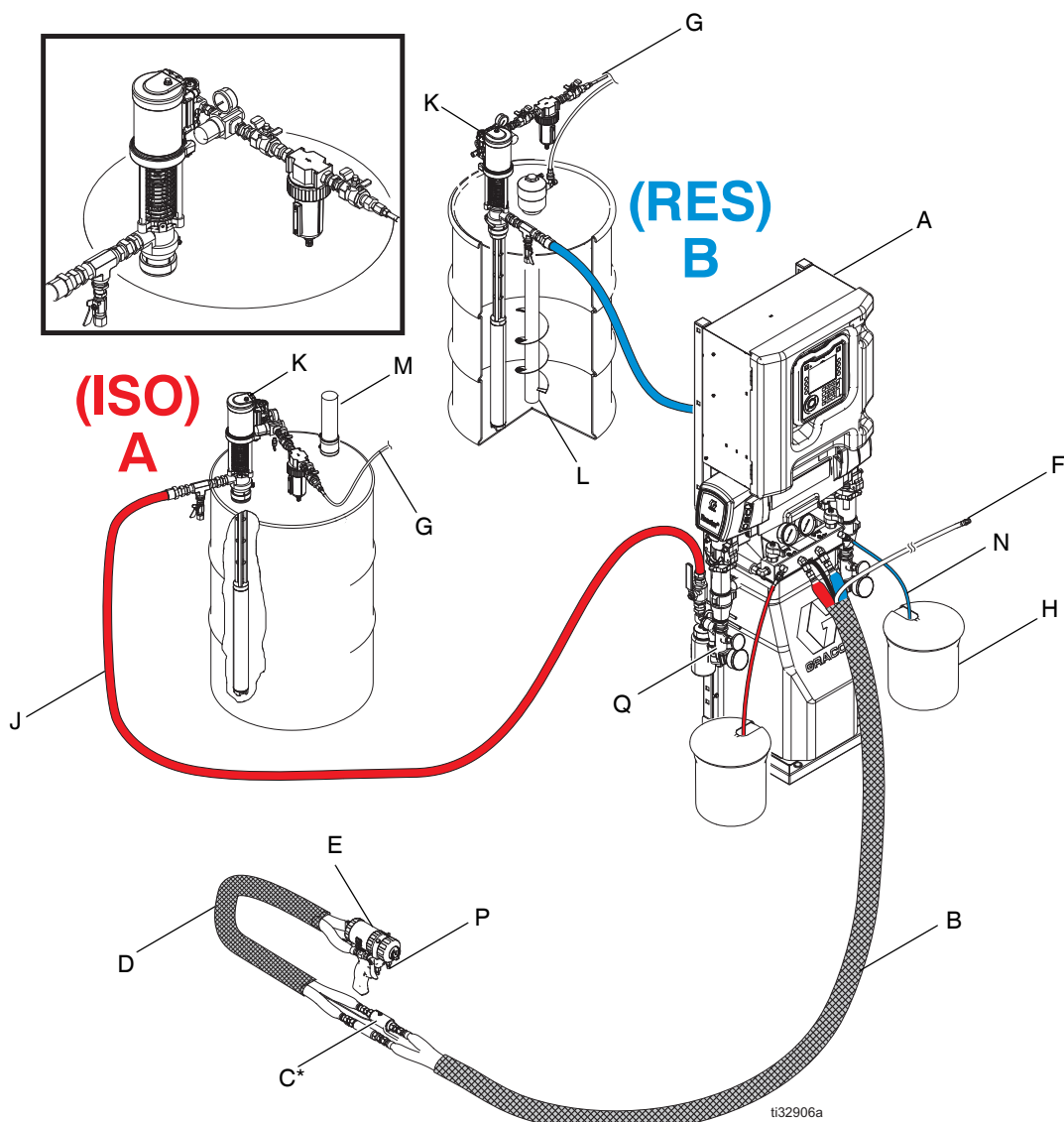

*Shown exposed for clarity. Wrap with tape during operation.

FIG. 1: Typical Installation without Circulation

NOTE: See **Typical Installation with Lubrication**, page 9, for required components.

Key:

- | | | | |
|---|---|---|---|
| A | Reactor Proportioner | H | Waste Containers |
| B | Heated Hose | J | Fluid Supply Lines (217382) |
| C | Fluid Temperature Sensor (FTS) | K | T3 Feed Pump (other items purchased separately) |
| D | Heated Whip Hose | L | Agitator |
| E | Fusion Spray Gun | M | Desiccant Dryer |
| F | Gun Air Supply Hose | N | Bleed Lines/Over Pressure Relief |
| G | Feed Pump Air Supply Lines, 3/8 in. (9.5 mm) ID minimum | P | Gun Fluid Manifold |
| | | Q | Fluid Filter |

Typical Installation with Circulation

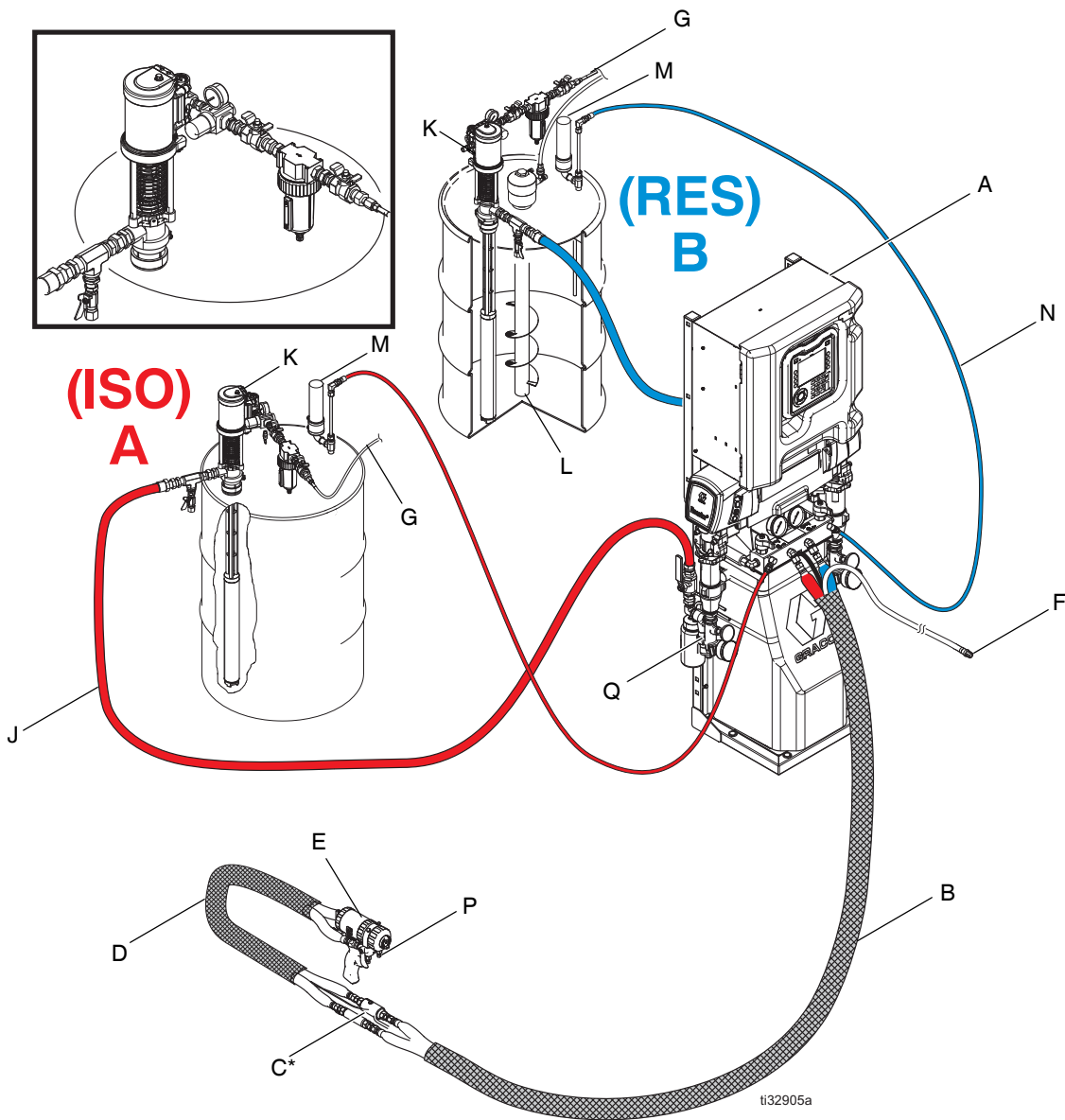

*Shown exposed for clarity. Wrap with tape during operation.

FIG. 2: Typical Installation with Circulation

NOTE: See Typical Installation with Lubrication, page 9, for required components.

Key:

- | | | | |
|---|---|---|---|
| A | Reactor Proportioner | K | T3 Feed Pump (other items purchased separately) |
| B | Heated Hose | L | Agitator |
| C | Fluid Temperature Sensor (FTS) | M | Desiccant Dryer |
| D | Heated Whip Hose | N | Recirculation/Over Pressure Relief Return Hoses |
| E | Fusion Spray Gun | P | Gun Fluid Manifold |
| F | Gun Air Supply Hose | Q | Fluid Filter |
| G | Feed Pump Air Supply Lines, 3/8 in. (9.5 mm) ID minimum | | |
| J | Fluid Supply Lines (217382) | | |

Typical Installation with Lubrication

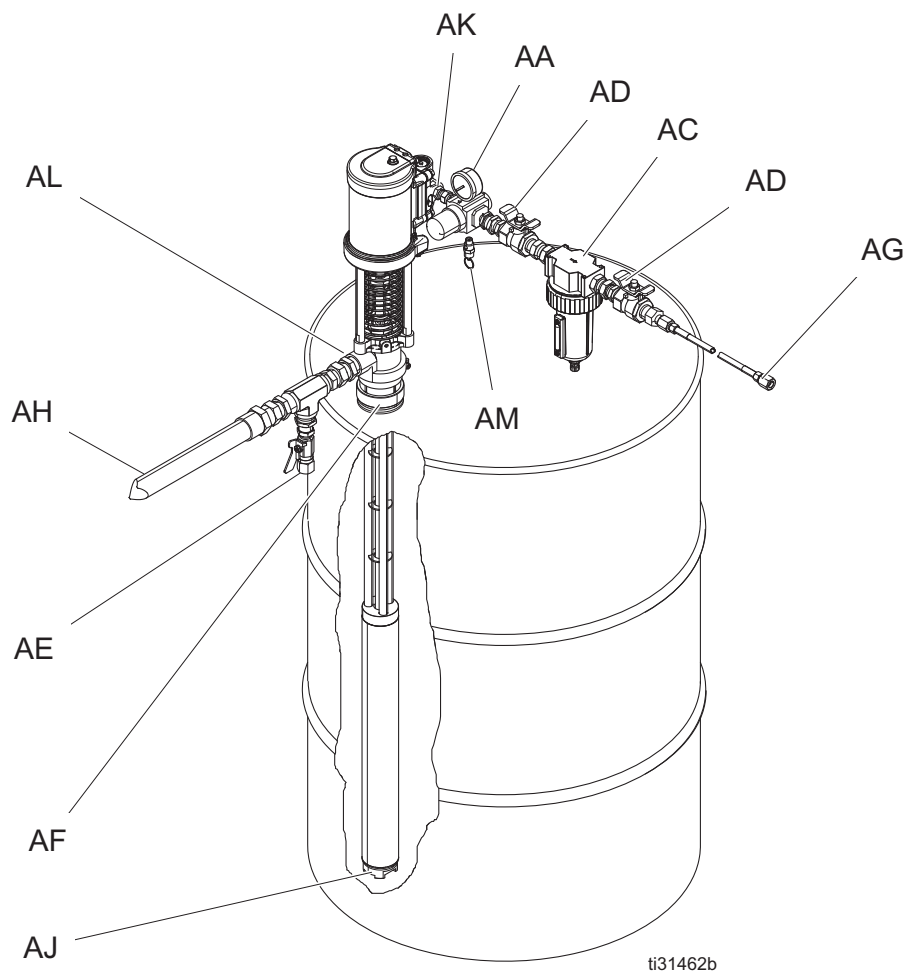

FIG. 3: Typical Installation with Lubrication

Key:

AA Pump Air Regulator

AC Air Line Filter*

AD Bleed-Type Master Air Valve (required)*

AE Fluid Drain Valve (required)*

AF Bung Adapter

AG Grounded Air Hose*

AH Grounded Fluid Hose*

AJ Pump Fluid Inlet

AK Pump Air Inlet, 1/4 npt(f)

AL Pump Fluid Outlet, 3/4 npt(f)

AM Pressure Relief Valve (100 psi, 6.8 bar, 0.68 MPa)

**Sold separately*

Installation



A bleed-type master air valve (AD) and a fluid drain valve (AE) are required in your system, to help reduce the risk of serious injury, including splashing fluid in the eyes or on the skin, and injury from moving parts when you are adjusting or repairing the pump.

- The bleed-type master air valve (AD) relieves air trapped between this valve and the pump after the pump is shut off. Trapped air can cause the pump to cycle unexpectedly and result in serious injury, including amputation. Install the valve close to the pump.
- The fluid drain valve (AE) helps relieve pressure in the displacement pump, hose, and dispensing valve when shutting off the pump. Actuating the dispensing valve to relieve pressure may not be sufficient, especially if there is a clog in the hose or the spray gun or dispensing valve.

NOTE: The items below are sold separately.

Air compressor: Ground according to manufacturer recommendations.

Air and fluid hoses: Use only electrically conductive hoses with a maximum of 300 ft (91 m) combined hose length to ensure grounding continuity. Check electrical resistance of hoses. If total resistance to ground exceeds 29 megohms, replace the hose immediately.

Spray gun or dispense valve: Ground through connection to a properly grounded fluid hose and pump.

Fluid supply container: Follow local code.

Solvent pails used when flushing: Follow local code. Use only conductive metal pails, placed on a grounded surface. Do not place the pail on a non-conductive surface, such as paper or cardboard, which interrupts grounding continuity.

Grounding



The equipment must be grounded to reduce the risk of static sparking. Static sparking can cause fumes to ignite or explode. Grounding provides an escape wire for the electric current.

To maintain grounding continuity when flushing or relieving pressure: Hold metal part of the spray gun/dispense valve firmly to the side of a grounded metal pail, then trigger the gun/valve.

See FIG. 4. Verify that the ground screw (GS) is attached and tightened securely to the air motor. Connect the other end of the ground wire (U) to a true earth ground.

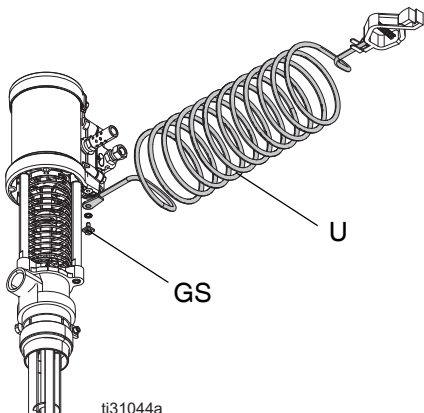

FIG. 4: Ground Wire

Accessories

To ensure maximum pump performance, be sure that all accessories are properly sized to meet your system's requirements.

Air Line

Install the following accessories in the order shown in **Typical Installation with Lubrication**, page 9, using adapters as necessary:

- **Bleed-type master air valve (AD):** required in the system to relieve air trapped between it and the air motor when the valve is closed.

NOTE: Be sure the air valves are easily accessible from the pump and located downstream from the air regulator.

- **Air line lubricator (AB):** provides automatic air motor lubrication.
- **Air line filter (AC):** removes harmful dirt and moisture from compressed air supply.
- **Second bleed-type air valve (AD):** isolates air line accessories for servicing. Locate upstream from all other air line accessories.

Fluid Line

- **Fluid drain valve (AE):** required in your system to relieve fluid pressure in the hose and gun or dispense valve. Install the drain valve so that it points down and the handle points up when the valve is opened.

Flush Before Using Equipment

The equipment was tested with lightweight oil, which is left in the fluid passages to protect parts. To avoid contaminating your fluid with oil, flush the equipment with a compatible solvent before using the equipment. See **Flush the Equipment**, page 14.

Setup

1. Connect the supplied air regulator (AR) to the swivel fitting on the air motor manifold. See FIG. 5.

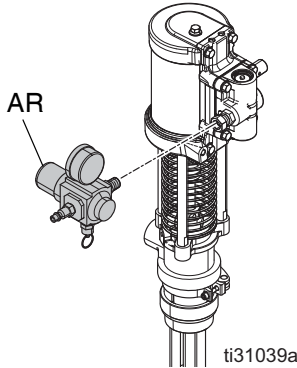

FIG. 5

2. Apply thread sealant to the male outlet fitting (not supplied) and insert into the outlet port. See FIG. 6.

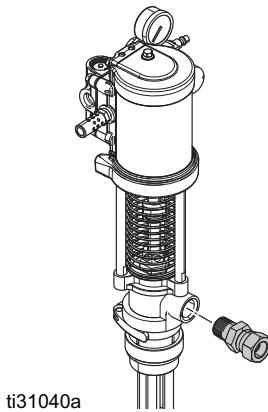

FIG. 6

3. Use labels provided to identify the appropriate pump for your material. See FIG. 7.

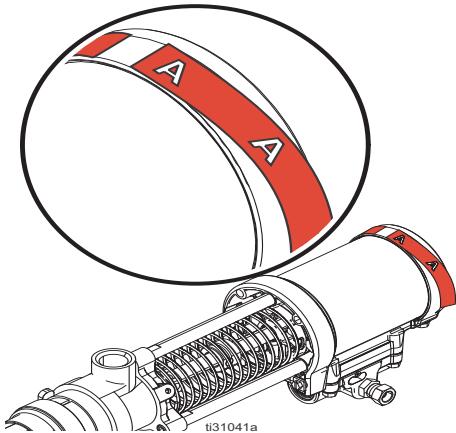

FIG. 7

4. Lubricate the bung adapter inside diameter and mounting threads. Install supplied handles and tighten jam nuts.
5. Ensure the gasket is in place and screw the bung adapter securely into the bunghole of the drum (1). Insert the pump through the adapter (2) and lock it in place (3). See FIG. 8.

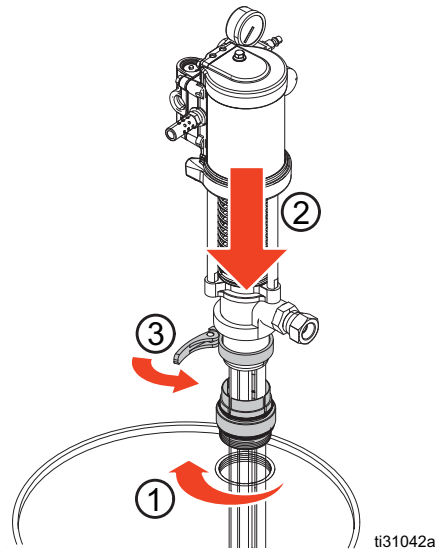

FIG. 8

6. Install air line (3/8 in. (9.5 mm) ID minimum) with quick disconnect air coupler provided. See FIG. 9.

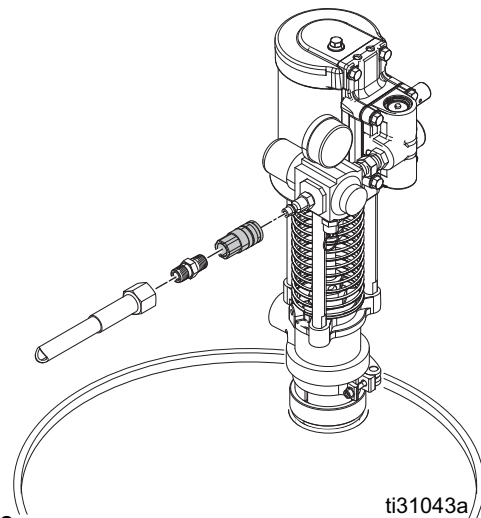

FIG. 9

- Model 24Z834 (carbon steel) only:** Model 24Z834 has a return port that can be used for circulating the fluid back to the drum. In a circulating system, remove the return port pipe plug (56) and connect a fluid return line to the 3/8 npt(f) return port.

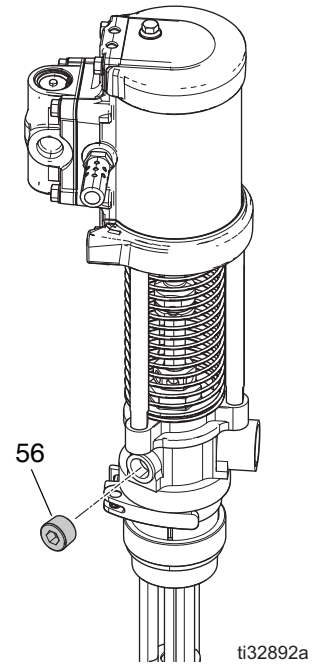

FIG. 10

Operation

Pressure Relief Procedure



Follow the Pressure Relief Procedure whenever you see this symbol.

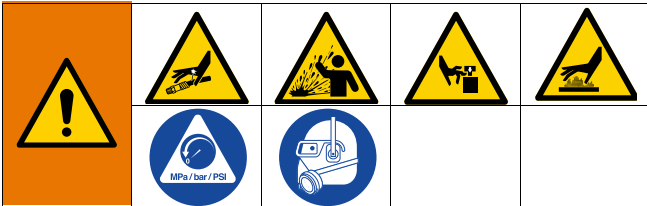

This equipment stays pressurized until pressure is manually relieved. To help prevent serious injury from pressurized fluid, such as skin injection, splashing fluid and moving parts, follow the Pressure Relief Procedure when you stop spraying and before cleaning, checking, or servicing the equipment.

1. Shut off the air to the pump.
2. Close the bleed-type master air valve (AD).
3. Hold a metal part of the dispense valve firmly to a grounded metal pail. Trigger the valve to relieve pressure.
4. Open all fluid drain valves in the system, having a waste container ready to catch drainage. Leave drain valve(s) open until you are ready to dispense again.
5. If you suspect the nozzle or hose is clogged or that pressure has not been fully relieved after following the steps above, **VERY SLOWLY** loosen the hose end coupling to relieve pressure gradually, then loosen completely. Clear hose or nozzle obstruction.

Flush the Equipment

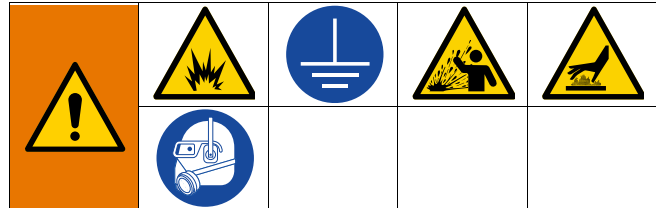

To avoid fire and explosion, always ground equipment and waste container. To avoid static sparking and injury from splashing, always flush at the lowest possible pressure.

Hot solvent may ignite. To avoid fire and explosion:

- Flush equipment only in a well-ventilated area
- Flush before changing colors, before fluid can dry in the equipment, before storing, and before repairing equipment.
- Flush at the lowest pressure possible. Check connectors for leaks and tighten as necessary.
- Flush with a fluid that is compatible with the fluid being dispensed and the equipment wetted parts.

1. Follow **Pressure Relief Procedure**, page 14.
2. Allow the fluid in the system to cool.
3. Remove spray tip and soak in solvent.
4. Place pump fluid inlet (AJ) in grounded metal pail containing cleaning fluid.
5. Set pump to lowest possible fluid pressure, and start pump.
6. Hold a metal part of the gun or dispense valve firmly to a grounded metal pail. Trigger the gun or dispense valve until clean solvent dispenses.
7. Remove gun or dispense valve from hose. See gun manual to further clean gun or dispense valve.
8. Follow **Pressure Relief Procedure**, page 14, and Remove fluid filter (Q) and soak in solvent. Replace filter cap.

Daily Startup

1. Verify that the air regulator is set to zero.
2. Connect the air line quick disconnect coupler to the transfer pump.
3. Turn on the main air supply.
4. Slowly tighten the air regulator until the transfer pump runs slowly.
5. Use the air regulator to control the pump pressure. See the **Pressure Conversion Chart**, page 29.

NOTICE

Never allow the pump to run dry of the fluid being pumped. A dry pump will quickly accelerate to a high speed and could cause damage to the pump. If the pump accelerates quickly or starts running too fast, stop it immediately and check the fluid supply. If the supply container is empty or air has been pumped into the lines, refill the container and prime the pump and the lines with fluid, or flush and leave it filled with a compatible solvent. Be sure to eliminate all air from the fluid system.

Do not attempt to operate unless it is securely mounted in a drum.

Daily Shutdown

1. Turn off air supply to the pump, or close the upstream ball valve.
2. Close the bleed type master air valve (AD).
3. When air pressure is bled off, set the air regulator to zero.

Troubleshooting



1. Follow **Pressure Relief Procedure**, page 14, before checking or repairing pump.
2. Check all possible problems and causes before disassembling pump.

Problem	Cause	Solution
The pump fails to operate	Damaged air valve	Replace or service air valve (14).
	Damaged pilot valve	Replace pilot valves (13).
	Inadequate air supply or restricted lines.	Clean lines or increase the air supply. See Technical Specifications , page 31.
	Closed or clogged air valves	Open or clear the valves.
	Clogged fluid hose or valve	Open or clear the valves.
The pump operates, but the output is low on both strokes	Clogged fluid hose or valve	Clear the hose or valves.
	Exhausted fluid supply	Refill the fluid supply and reprime the pump.
	Worn or damaged valves or seals	Service the valves or seals.
The pump operates, but the output is low on the downstroke	Held open or worn intake valve	Clear or service the valve.
	Worn or damaged valves or seals	Service the valves or seals.
The pump operates, but the output is low on the upstroke	Held open or worn piston valve	Clear or service the valve.
	Worn or damaged valves or seals	Service the valves or seals.
Erratic or accelerated operation	Exhausted fluid supply	Refill the fluid supply and reprime the pump.
Pump slowly moves after fluid shutoff in the downstroke	Clogged or dirty intake valve check ball	Clean ball and seat.
	Worn or damaged valves or seats	Install repair kit.
Pump moves slowly after fluid shutoff in the downstroke	Clogged or dirty intake valve check ball	Clean ball and seat.
	Worn or damaged valves or seats	Install repair kit.
Pump moves slowly after fluid shutoff in the upstroke	Clogged or dirty piston ball or seat	Clean ball and seat.
	Worn or damaged valves or seats	Install repair kit.
Air continuously escapes around piston rod	Damaged U-cups (part 7)	Replace piston rod U-cup (part 7).
Air continuously escapes from muffler	Damaged air valve plate (13) or cup (14)	Replace or service air valve (14).
Air motor “bounces” at top of stroke	Damaged bottom valve	Replace bottom pilot valve (13).

Problem	Cause	Solution
Air motor “bounces” at bottom of stroke	Damaged top valve	Replace top pilot valve (13).
Icing inside motor	Air motor operating at high pressure or high cycle rate	Reduce pressure, cycle rate, or duty cycle of motor. Reduce dew point of compressed air in moisture-coalescing filter.

Parts

Air Motor

Stainless Steel (25C864)

Carbon Steel (17U110)

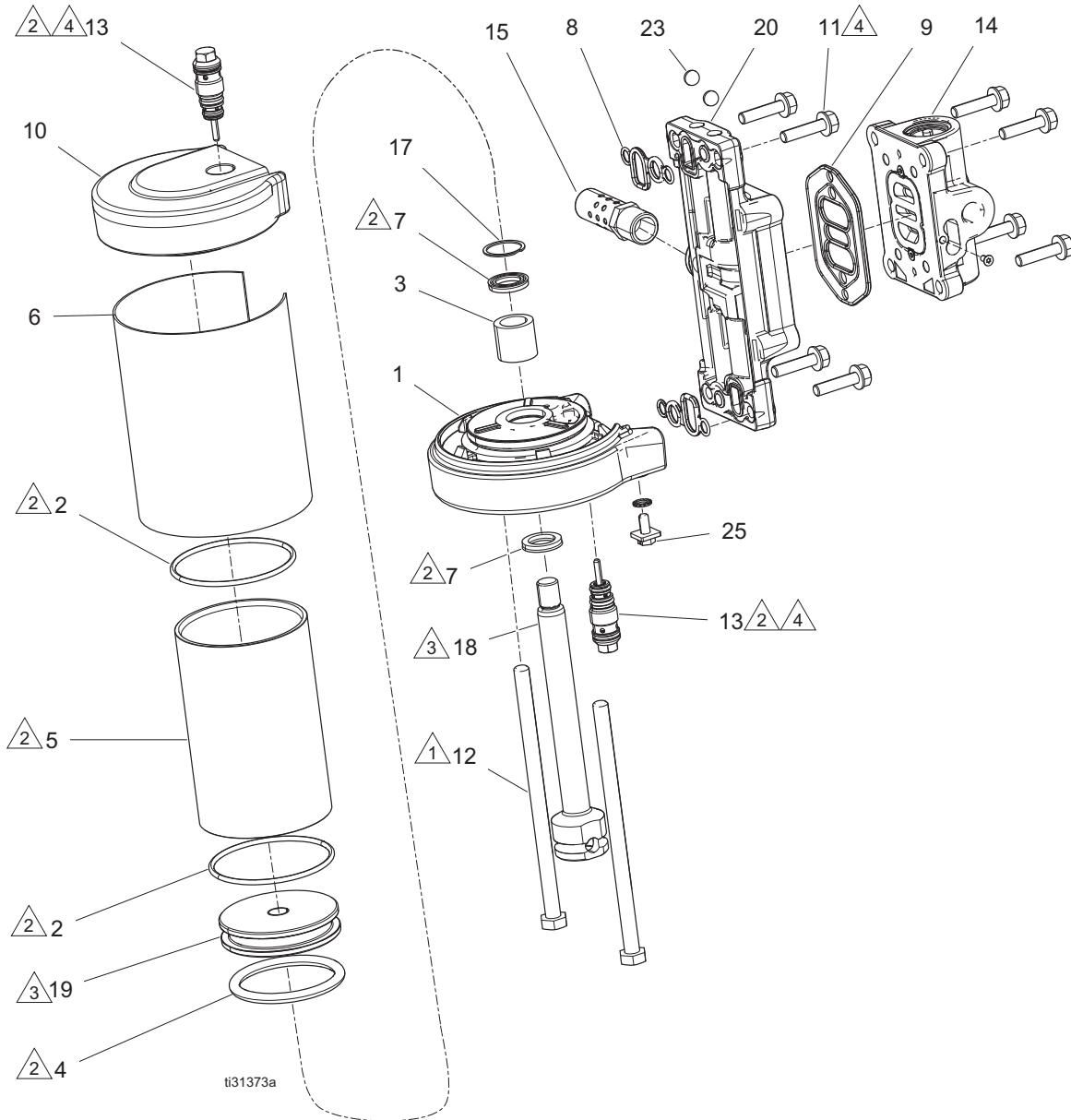

- Torque to 11-13 ft-lb (15-18 N•m).
- Apply lubricant.
- Apply adhesive and then torque to 35-40 ft-lb (47.4-54.2 N•m).
- Torque to 95-105 in-lb (10.7-11.8 N•m).

Parts List

Ref.	Part	Description	Qty.	Ref.	Part	Description	Qty.
1†	-----	COVER, lower, 2.5	1	18†	-----	PISTON, air motor, rod, T3	1
2†	108993	PACKING, o-ring	2	19†	-----	PISTON, air motor, T3	1
3†	-----	BEARING, 9/16	1	20*	-----	MANIFOLD, medium, short	1
4†	117370	PACKING, o-ring	1	23*	105444	BALL, 0.31250	4
5	15M289	CYLINDER, motor, 2.5	1	25†	116343	SCREW, ground	1
6	17S538	LABEL, air motor, stainless steel	1				
	17S539	LABEL, air motor, carbon steel	1	†	<i>Parts included in air motor rebuilt kit 25M555 (purchase separately).</i>		
7†	-----	SEAL, u-cup, 0.562	2	‡	<i>Parts included in valve replacement kit 24A351 (purchase separately).</i>		
8*	-----	GASKET, cover, small	2	◆	<i>Parts included in pilot valve kit 24A366 (2 pack, purchase separately).</i>		
9‡*	-----	SEAL, air valve, manifold	1	*	<i>Parts included in motor manifold kit 24A579 (purchase separately).</i>		
10	15M291	COVER, motor, 2.5	1				
11‡*	-----	SCREW, M6 x 25, thread forming	8				
12	15M314	SCREW, cap	2				
13◆	-----	VALVE, pilot	2				
14‡	-----	VALVE, air, small	1				
15	15M213	MUFFLER, 3/8	1				
17†	-----	RING, retaining	1				

Air Valve

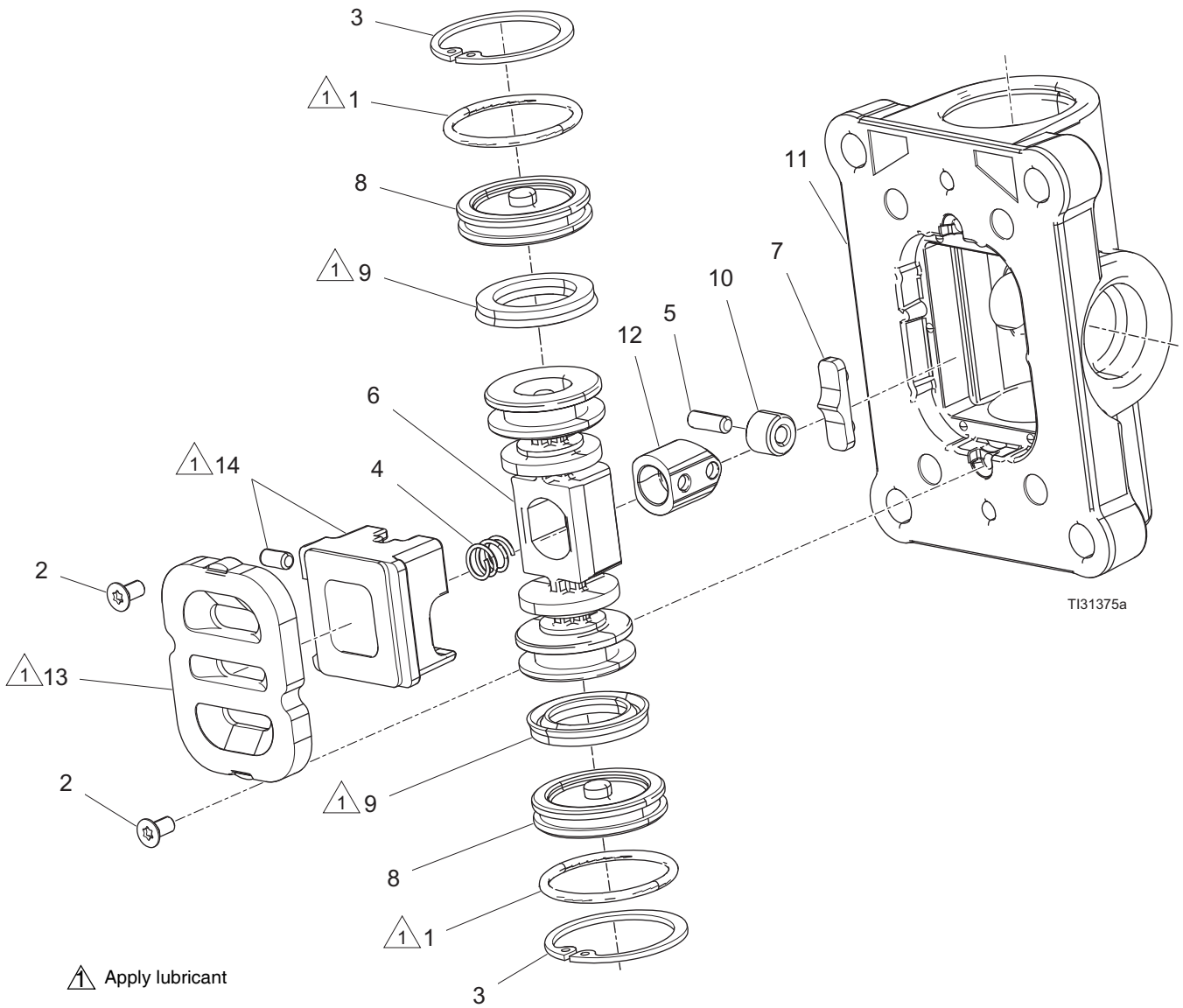

Parts List

Ref.	Part	Description	Qty.	
1†‡	-----	O-RING, 018 buna	2	† <i>Parts included in valve rebuild kit 25M552 (purchase separately).</i>
2†‡	-----	SCREW, M3, thread forming	2	‡ <i>Parts included in valve seal kit 25M553 (purchase separately).</i>
3†	-----	RING, snap, 1.0	2	
4†	-----	SPRING, detent, small	1	
5†	-----	PIN, detent, small	1	
6†	15K903	PISTON, air valve, small	1	
7†	-----	CAM, detent	1	
8†	-----	PLUG, air valve, small	2	
9†‡	-----	SEAL, u-cup, bevel lip	2	
10	-----	ROLLER, detent, small	1	
11	-----	HOUSING, air valve, small, npt	1	
12†	-----	PISTON, detent, small, machined	1	
13†	-----	PLATE, air valve, machined	1	
14†	-----	CUP, air valve, machined	1	

Pump Lower

Stainless Steel (26A304)

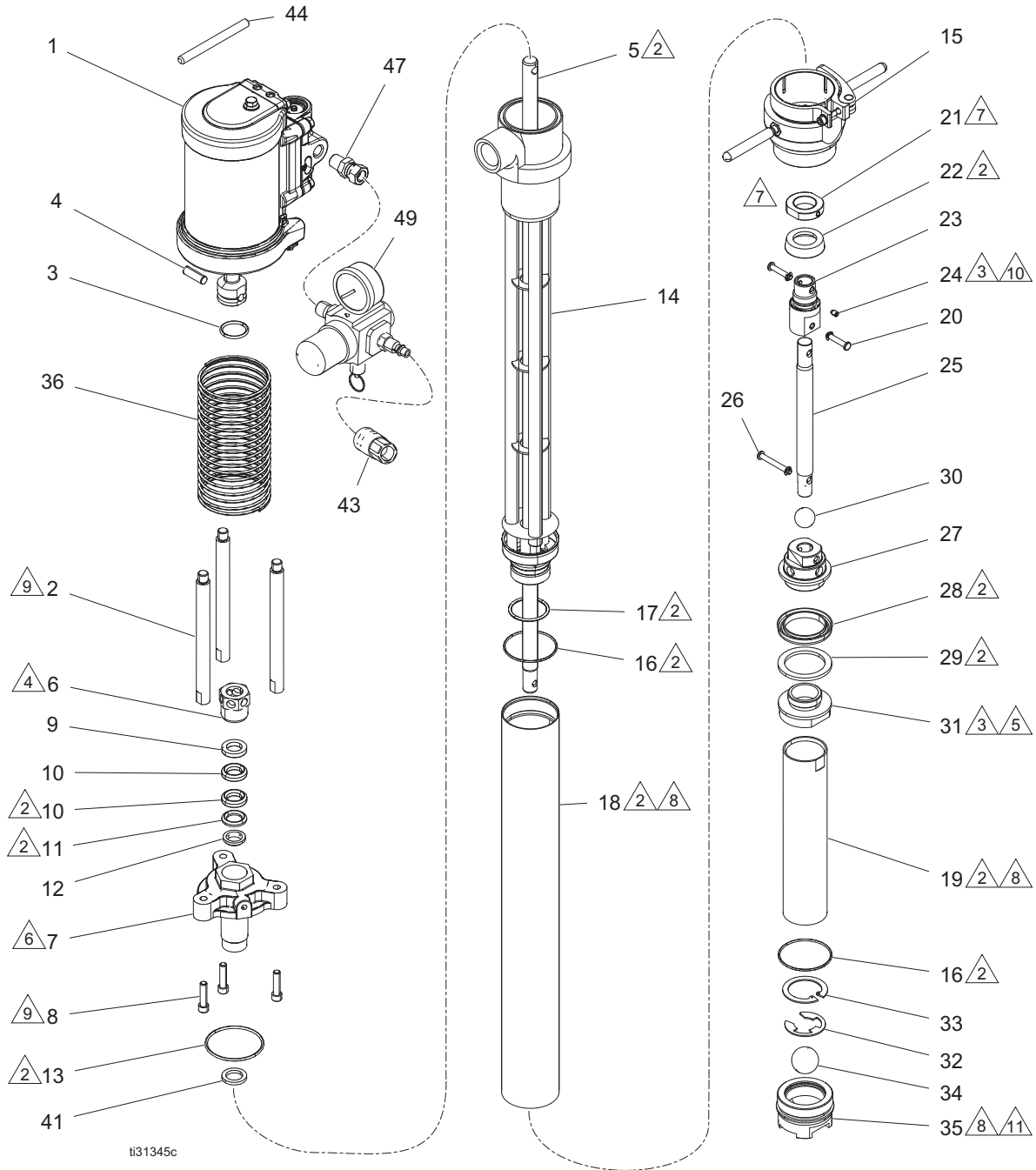

- Apply lubricant.
- Apply sealant.
- Turn packing nut (6) down until flush with stack. Tighten an additional 1/8 to 1/4 turn.
- Torque to 45-55 ft-lb (61.0-74.5 N•m).
- Torque to 30-40 ft-lb (40.6-54.2 N•m).

- Torque to 15-25 ft-lb (20.3-33.8 N•m).
- Torque to 10-12 ft-lb (13.5-16.2 N•m).
- Torque to 110-120 in-lb (12.4-13.5 N•m).
- Torque to 20-30 ft-lb (27.1-40.6 N•m).
- Apply sealant to threads.

Parts List

Ref.	Part	Description	Qty.	Ref.	Part	Description	Qty.
1	25C864	MOTOR, air, 2.5, T3	1	26‡	120295	PIN, clevis, 3/16 dia x 1.5	1
2	17P251	ROD, tie, T3	3	27	15J570	HOUSING, piston	1
3	514129	PACKING, o-ring	1	28‡	15J565	PACKING, u-cup	1
4	196762	PIN, straight	1	29‡	15J566	RING, wear	1
5	17R237	PISTON, rod, lower, T3	1	30‡	103462	BALL, SST, 715	1
6	15J555	NUT	1	31	24J531	VALVE, piston	1
7	24J530	FLANGE	1	32	120735	RING, snap, E series	1
8	120348	SCREW, SHCS, 1/4-20 x 1.00	3	33	120734	RING, retaining, internal	1
9†	15J558	GLAND, packing (female)	1	34‡	107167	BALL, SST	1
10†	15J557	PACKING, vee, PTFE	2	35	24J533	VALVE, foot	1
11†	15J556	GLAND, packing (male)	1	36	17R693	SPRING, guard, T3	1
12†	15J559	WIPER, rod	1	41	15J560	GASKET, PTFE	1
13	15C638	O-RING, PTFE, encapsulated	1	43	114558	COUPLER, line, air	1
14	24J536	BODY, pump, 2:1	1	44	15H197	TOOL, spanner wrench	1
15	26A699	ADAPTER, bung, 2 in., EZ removal	1	45	15K008	LABEL, material identification	1
15a	25N940	KIT, handles, bung adapter		46	15Y118	LABEL, made in the USA	1
16‡	106258	PACKING, o-ring	2	47	156823	FITTING, swivel	1
17‡	113944	PACKING, o-ring	1	49	24Z963	REGULATOR, T3, quick connect	1
18	24J532	TUBE, suction	1				
19	24J534	CYLINDER, fluid	1				
20‡	120294	PIN, clevis, 3/16 diameter x 1	2				
21	15J563	COLLAR, retaining	1				
22‡	15J562	PACKING, piston cup	1				
23	15U575	PISTON, upper fluid	1				
24	101194	SCREW, set	1				
25	15U574	SHAFT, transfer, lower	1				

† Parts included in upper seal kit 25M793
(purchase separately).

‡ Parts included in lower seal kit 247883
(purchase separately).

Carbon Steel (24Z834)

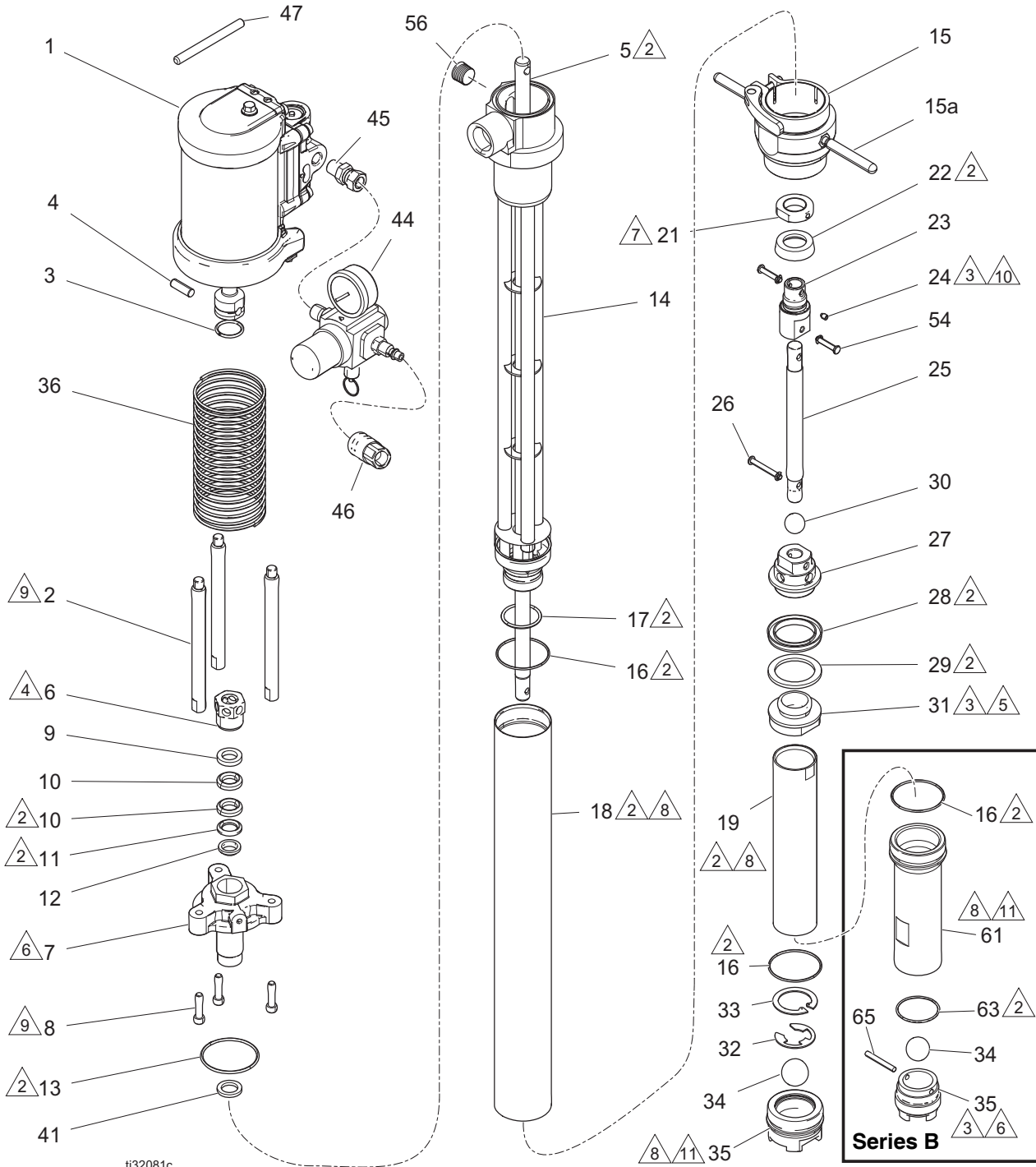

- Apply lubricant.
- Apply sealant.
- Turn packing nut (6) down until flush with stack. Tighten an additional 1/8 to 1/4 turn.
- Torque to 45-55 ft-lb (61.0-74.5 N•m).
- Torque to 30-40 ft-lb (40.6-54.2 N•m).

- Torque to 15-25 ft-lb (20.3-33.8 N•m).
- Torque to 10-12 ft-lb (13.5-16.2 N•m).
- Torque to 110-120 in-lb (12.4-13.5 N•m).
- Torque to 20-30 ft-lb (27.1-40.6 N•m).
- Apply sealant to threads.

Parts List

Ref.	Part	Description	Qty.	Ref.	Part	Description	Qty.
1	17U110	MOTOR, air, 2.5 in., T3	1	28†‡	15J565	PACKING, u-cup	1
2	17P251	ROD, tie, T3	3	29†‡	15J566	RING, wear	1
3	514129	PACKING, o-ring	1	30†‡	103462	BALL, sst, 715	1
4	196762	PIN, straight	1	31	15J567	VALVE, piston	1
5	17R237	PISTON, rod, lower, T3, series A	1	32	120735	RING, snap	1
**	18A417	CONNECTING ROD, T3, series B	1	33	120734	RING, retaining, internal	1
6	15J555	NUT	1	34†	107167	BALL, sst, series A	1
7	17R705	FLANGE, mounting, T3	1	**‡	101917	BALL, sst, 7/8 in., series B	1
8	120348	SCREW, shcs, 1/4-20 x 1.00	3	35	15J569	VALVE, foot, series A	1
9*	15J558	GLAND, packing, female	1	**	24T262	HOUSING, valve, intake, series B	
10*	15J557	PACKING, vee, PTFE	2	36	17R693	SPRING, guard, T3	1
11*	15J556	GLAND, packing, male	1	41	15J560	GASKET, PTFE	1
12*	15J559	WIPER, rod	1	44	24Z963	REGULATOR, T3, quick connect	1
13	15C638	O-RING, PTFE, encapsulated	1	45	156823	FITTING, swivel	1
14	26A341	BODY, pump, T3	1	46	114558	COUPLER, line, air	1
15	26A699PKG	ADAPTER, bung, 2 in. EZ removal	1	47	15H197	TOOL, spanner wrench	1
15a	25N940	KIT, handles, bung adapter		53	100361	PLUG, pipe	1
16†‡	106258	PACKING, o-ring	2	54†‡	120294	PIN, clevis, 3/16 diameter x 1	2
17†‡	113944	PACKING, o-ring	1	55†‡	120295	PIN, clevis, 3.16 diameter x 1.5	1
18	17R289	TUBE, suction, T3, series A	1	56	101748	PLUG, pipe, sst	1
**	18A411	TUBE, suction, T3, series B	1	61**	18A409	TUBE, section, T3, series B	1
19	17R290	CYLINDER, fluid, pump, T3, series A	1	63†**	103414	O-RING	1
**	18A413	CYLINDER, fluid, pump, T3, series B	1	65**	164250	PIN, ball stop	1
21	17R291	COLLAR, retaining, T3	1	* Parts included in upper seal kit 25M793 (purchase separately).			
22†‡	15J562	PACKING, piston cup	1	† Parts included in Series A lower seal kit 247883 (purchase separately).			
23	17R427	PISTON, upper fluid, T3	1	‡ Parts included in Series B lower seal kit 26C757 (purchase separately).			
24	101194	SCREW, set	1	** Parts included in upgrade kit 26C589 for upgrading carbon steel lowers from Series A to Series B.			
25	17R292	SHAFT, transfer, lower, T3, series A	1				
**	18A415	SHAFT, transfer, lower, T3, series B	1				
27	17R293	HOUSING, piston, T3	1				

Accessories

Grounding Clamp (not included)

Part	Description
103538	CLAMP, ground

Qty.
1

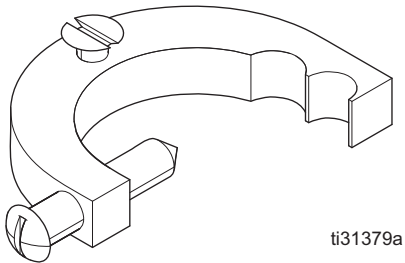

Bleed-Type Master Air Valve (not included)

Maximum Working Pressure: 300 psi (2.1 MPa, 21 bar)

Part	Description	Qty.
107142	VALVE, ball, vented; 1/2 npt(m) inlet x 1/2 npt(f) outlet	1

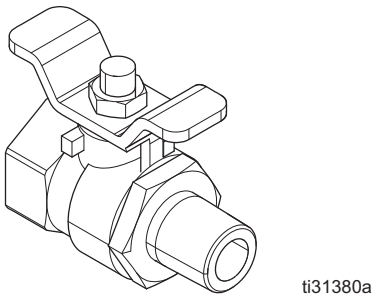

Air Line Filter (not included)

Maximum Working Pressure:
250 psi (1.7 MPa, 17.5 bar)

Part	Description	Qty.
106149	FILTER, air line; 1/2 npt(f) inlet and outlet	1

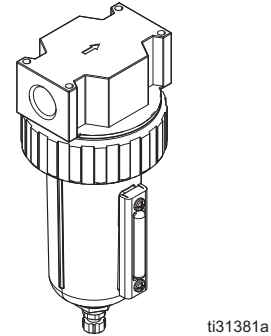

Air Line Filter and Regulator (not included)

Maximum Working Pressure: 180 psi (1.3 MPa, 13 bar)

Part	Description	Qty.
202660	FILTER, air; includes gauge and two 1/4 npt(m) outlet valves, 50 micron filter element with 100 mesh inlet strainer; 1/2 npt(f) inlet; flow rate is over 50 scfm (1.4 m ³ /min)	1

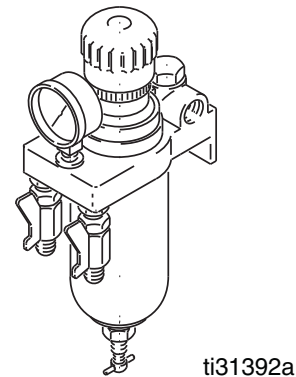

Air Regulator and Gauge (included)

Maximum Working Pressure: 100 psi (0.7 MPa, 7 bar)

Part	Description	Qty.
24Z963	REGULATOR, gauge	1

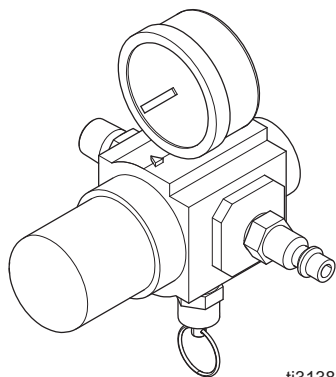

ti31383a

Fluid Drain Valve (not included)

Maximum Working Pressure: 500 psi (3.5 MPa, 35 bar)

Part	Description	Qty.
208630	VALVE, ball; 1/2 npt(m) x 3/8 npt(f) for non-corrosive fluids; carbon steel and PTFE	1
237534	VALVE, ball; 3/8 npt(m) x 3/8 npt(f) for corrosive fluids; SST and PTFE	1

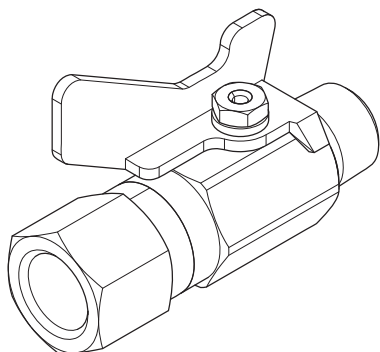

ti31384a

Return Tube Kit (not included)

Part	Description	Qty.
246477	KIT, carbon steel return tube	1
24D106	KIT, stainless steel return tube	1
246978	KIT, carbon steel return tube; with hose	1
24E379	KIT, carbon steel return tube; with moisture-loc hose	1
24D107	KIT, stainless steel return tube; with moisture-loc hose	1
247616	KIT, desiccant dryer, no return tube	1

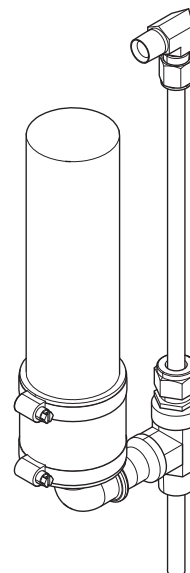

ti31385a

Performance Chart

Calculate Fluid Outlet Pressure

To calculate fluid outlet pressure (psi) at a specific fluid flow (gpm) and operating air pressure (psi), use the following instructions and FIG. 11.

Locate desired fluid flow along bottom of chart.

Follow the vertical line to the intersection with the selected air pressure curve (black). Refer to the Fluid Pressure measurements at left to determine fluid outlet pressure.

Calculate Pump Air Consumption

To calculate pump air consumption (scfm) at a specific fluid flow (gpm) and air pressure (psi), use the following instructions and FIG. 11.

Locate desired fluid flow along bottom of chart.

Follow the vertical line to the intersection with the selected air pressure curve (grey). Follow horizontally right to read air consumption.

Key: Air Pressure

- A 100 psi (0.7 MPa, 7 bar)
- B 70 psi (0.5 MPa, 4.8 bar)
- C 40 psi (0.3 MPa, 2.8 bar)

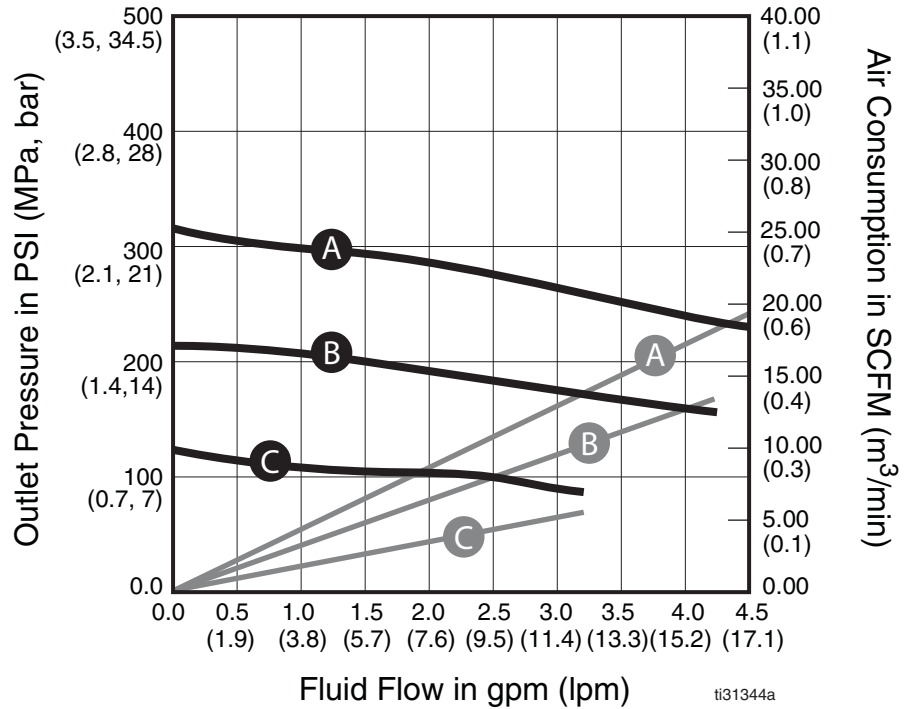

FIG. 11: Pump Performance

Pressure Conversion Chart

Fluid Pressure	Air Pressure		
	T1	T2	T3
50 psi (3.4 bar, 0.34 MPa)	25.0 psi (1.3 bar, 0.13 MPa)	22.2 psi (1.5 bar, 0.15 MPa)	16.7 psi (1.1 bar, 0.11 MPa)
75 psi (5.1 bar, 0.51 MPa)	37.5 psi (2.5 bar, 0.25 MPa)	33.3 psi (2.3 bar, 0.23 MPa)	25.0 psi (1.7 bar, 0.17 MPa)
100 psi (6.8 bar, 0.68 MPa)	50.0 psi (3.4 bar, 0.34 MPa)	44.4 psi (3.0 bar, 0.3 MPa)	33.3 psi (2.2 bar, 0.22 MPa)
125 psi (8.6 bar, 0.86 MPa)	62.5 psi (4.3 bar, 0.43 MPa)	55.6 psi (3.8 bar, 0.38 MPa)	41.7 psi (2.8 bar, 0.28 MPa)
150 psi (10.3 bar, 1.03 MPa)	75.0 psi (5.1 bar, 0.51 MPa)	66.7 psi (4.5 bar, 0.45 MPa)	50.0 psi (3.4 bar, 0.34 MPa)
200 psi (13.7 bar, 1.37 MPa)	100.0 psi (6.8 bar, 0.68 MPa)	88.9 psi (6.1 bar, 0.61 MPa)	66.7 psi (4.5 bar, 0.45 MPa)
250 psi (17.2 bar, 1.72 MPa)	125.0 psi (8.6 bar, 0.86 MPa)	111.1 psi (7.6 bar, 0.76 MPa)	83.3 psi (5.7 bar, 0.57 MPa)
300 psi (20.6 bar, 2.06 MPa)	150.0 psi (10.3 bar, 1.03 MPa)	133.3 psi (9.1 bar, 0.91 MPa)	100.0 psi (6.8 bar, 0.68 MPa)

Standard Cubic Feet/Minute (SCFM) Requirement Chart

*Air flow at typical application pressure. See fluid performance chart for more details.

Fluid Pressure	Fluid Pressure			Fluid Flow	*Air Flow
	T1	T2	T3		
60 psi (4.1 bar, 0.41 MPa)	30 psi (2.1 bar, 0.21 MPa)	27 psi (1.7 bar, 0.17 MPa)	20 psi (1.4 bar, 0.14 MPa)	1 gpm (3.8 lpm)	3 scfm (85.0 lpm)
120 psi (8.3 bar, 0.83 MPa)	60 psi (4.1 bar, 0.41 MPa)	53 psi (3.6 bar, 0.36 MPa)	40 psi (2.8 bar, 0.28 MPa)	2 gpm (7.6 lpm)	6 scfm (170.0 lpm)
180 psi (12.4 bar, 1.24MPa)	90 psi (6.2 bar, 0.62 MPa)	80 psi (5.5 bar, 0.5.5 MPa)	60 psi (4.1 bar, 0.41 MPa)	3 gpm (11.4 lpm)	11 scfm (311.5 lpm)

Dimensions

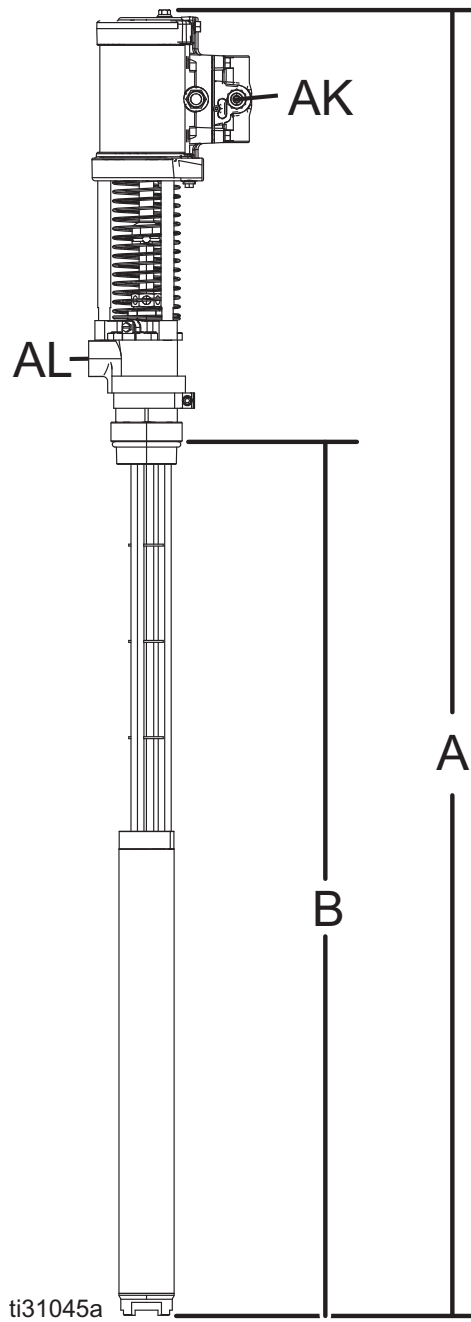

Ref.	Dimension	Measurement
A	Overall Length	50.3 in. (127.8 cm)
B	Pump Length	33.7 in. (85.6 cm)
AK	Air Inlet	1/4 in. npt
AL	Fluid Outlet	3/4 in. npt(f)

Technical Specifications

T3 3:1 Ratio Transfer Pump		
	US	Metric
Pressure ratio	3:1	
Maximum fluid working pressure	315 psi	2.17 MPa, 21.7 bar
Maximum air inlet pressure	100 psi	0.68 MPa, 6.8 bar
Maximum continuous outlet flow	4.5 gpm	17.03 lpm
Pump cycles per 1 gallon (3.8 liters)	30	
Maximum recommended pump speed for continuous operation	120 cpm	
Gallons (liters) per pump cycle	0.034 gpm	0.128 lpm
Maximum ambient operating temperature	120° F	49° C
Maximum fluid temperature	190° F	88° C
Inlet/Outlet Sizes		
Air inlet size	1/4-18 in. npt(f)	
Fluid outlet size	3/4-14 in. npt (f)	
Materials of Construction		
Wetted materials on 26A304	Carbon steel, stainless steel, PTFE	
Wetted materials on 24Z834	Carbon steel, stainless steel, PTFE	
Weight		
All models	22 lb.	10 kg
Noise (dBa)		
Maximum sound pressure*	72.9 dBa @ 70 psi (0.48 MPa, 4.8 bar)	
Maximum sound power**	82.8 dBS @ 70 psi (0.48 MPa, 4.8 bar), 20 cpm	
<i>*Sound pressure measured 3.28 feet (1 meter) from equipment.</i>		
<i>**Sound power measured per ISO-9614-2.</i>		
Notes		
All trademarks or registered trademarks are the property of their respective owners.		

Graco Standard Warranty

Graco warrants all equipment referenced in this document which is manufactured by Graco and bearing its name to be free from defects in material and workmanship on the date of sale to the original purchaser for use. With the exception of any special, extended, or limited warranty published by Graco, Graco will, for a period of twelve months from the date of sale, repair or replace any part of the equipment determined by Graco to be defective. This warranty applies only when the equipment is installed, operated and maintained in accordance with Graco's written recommendations.

This warranty does not cover, and Graco shall not be liable for general wear and tear, or any malfunction, damage or wear caused by faulty installation, misapplication, abrasion, corrosion, inadequate or improper maintenance, negligence, accident, tampering, or substitution of non-Graco component parts. Nor shall Graco be liable for malfunction, damage or wear caused by the incompatibility of Graco equipment with structures, accessories, equipment or materials not supplied by Graco, or the improper design, manufacture, installation, operation or maintenance of structures, accessories, equipment or materials not supplied by Graco.

This warranty is conditioned upon the prepaid return of the equipment claimed to be defective to an authorized Graco distributor for verification of the claimed defect. If the claimed defect is verified, Graco will repair or replace free of charge any defective parts. The equipment will be returned to the original purchaser transportation prepaid. If inspection of the equipment does not disclose any defect in material or workmanship, repairs will be made at a reasonable charge, which charges may include the costs of parts, labor, and transportation.

THIS WARRANTY IS EXCLUSIVE, AND IS IN LIEU OF ANY OTHER WARRANTIES, EXPRESS OR IMPLIED, INCLUDING BUT NOT LIMITED TO WARRANTY OF MERCHANTABILITY OR WARRANTY OF FITNESS FOR A PARTICULAR PURPOSE.

Graco's sole obligation and buyer's sole remedy for any breach of warranty shall be as set forth above. The buyer agrees that no other remedy (including, but not limited to, incidental or consequential damages for lost profits, lost sales, injury to person or property, or any other incidental or consequential loss) shall be available. Any action for breach of warranty must be brought within two (2) years of the date of sale.

GRACO MAKES NO WARRANTY, AND DISCLAIMS ALL IMPLIED WARRANTIES OF MERCHANTABILITY AND FITNESS FOR A PARTICULAR PURPOSE, IN CONNECTION WITH ACCESSORIES, EQUIPMENT, MATERIALS OR COMPONENTS SOLD BUT NOT MANUFACTURED BY GRACO. These items sold, but not manufactured by Graco (such as electric motors, switches, hose, etc.), are subject to the warranty, if any, of their manufacturer. Graco will provide purchaser with reasonable assistance in making any claim for breach of these warranties.

In no event will Graco be liable for indirect, incidental, special or consequential damages resulting from Graco supplying equipment hereunder, or the furnishing, performance, or use of any products or other goods sold hereto, whether due to a breach of contract, breach of warranty, the negligence of Graco, or otherwise.

FOR GRACO CANADA CUSTOMERS

The Parties acknowledge that they have required that the present document, as well as all documents, notices and legal proceedings entered into, given or instituted pursuant hereto or relating directly or indirectly hereto, be drawn up in English. Les parties reconnaissent avoir convenu que la rédaction du présente document sera en Anglais, ainsi que tous documents, avis et procédures judiciaires exécutés, donnés ou intentés, à la suite de ou en rapport, directement ou indirectement, avec les procédures concernées.

Graco Information

For the latest information about Graco products, visit www.graco.com.

For patent information, see www.graco.com/patents.

TO PLACE AN ORDER, contact your Graco distributor or call to identify the nearest distributor.

Phone: 612-623-6921 or Toll Free: 1-800-328-0211 Fax: 612-378-3505

All written and visual data contained in this document reflects the latest product information available at the time of publication. Graco reserves the right to make changes at any time without notice.

Original instructions. This manual contains English. MM 3A5180

Graco Headquarters: Minneapolis

International Offices: Belgium, China, Japan, Korea

GRACO INC. AND SUBSIDIARIES • P.O. BOX 1441 • MINNEAPOLIS MN 55440-1441 • USA
Copyright 2017, Graco Inc. All Graco manufacturing locations are registered to ISO 9001.

www.graco.com
Revision L, August 2019