

GL-1X[®] and GL-1XL[®] Injector Repair Kit

3A6485A

EN

Service instructions for repairing GL-1X and GL-1XL injectors.

Maximum Working Pressure: 6000 psi (41 MPa, 414 bar)

Models:

25A080: GL-1XL Models

25A081: GL-1X Models



Important Safety Instructions

Read all warnings and instructions in this manual and related automatic lubrication system instruction manuals before using this equipment. Save all instructions.

Kit Parts and the complete injector assembly are shown on page 7.





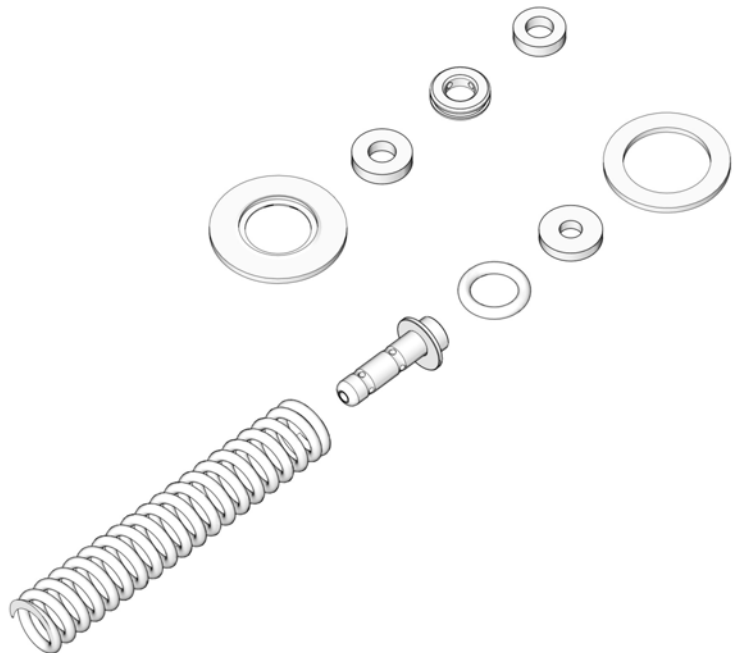

Related Manuals

335023 - GL-1X and GL-1 XL Injectors



Instructions

Disassembly

 WARNING				
				
<p>PRESSURIZED FLUID HAZARD This equipment stays pressurized until pressure is manually relieved. To help prevent serious injury from pressurized fluid, such as skin injection, splashing fluid and moving parts, follow the Pressure Relief Procedure when you stop pumping and before cleaning, checking or servicing the equipment.</p> <p>PERSONAL PROTECTIVE EQUIPMENT Wear appropriate protective equipment when in the work area to help prevent serious injury, including eye injury, hearing loss, inhalation of toxic fumes, and burns.</p>				

1. Disconnect and isolate the power supply to the lubrication controller and to the pump.
2. **Relieve system pressure.** See the Pressure Relief Procedure provided in the pump manual for your system.
3. Disconnect fluid supply lines from injectors.
4. Disconnect lube point feed lines from the injector outlets.
5. Take the injector manifold out of service.
6. Remove the injector(s) from the manifold by loosening and removing adapter bolts (20) as shown in FIG. 1.

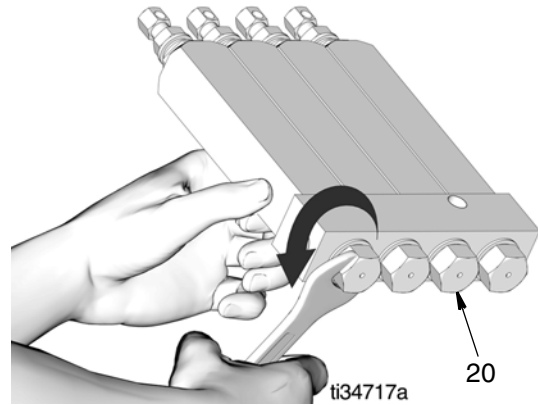

FIG. 1

NOTE: Single injectors can be secured in a vise to loosen and remove adapter bolt (20) as shown in FIG. 2.

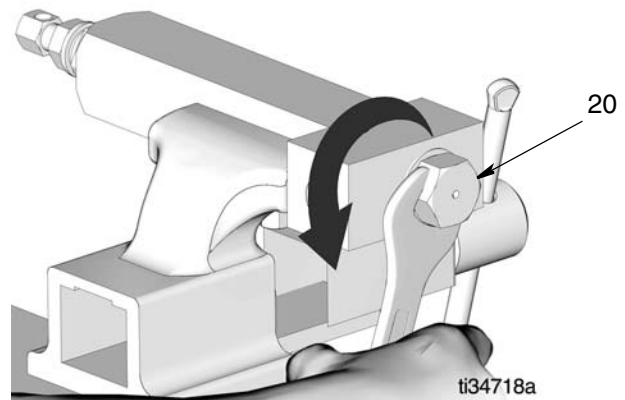

FIG. 2

7. Remove steel gasket (19), manifold (18) and bonded washer (17) from adapter bolt (20) (FIG. 3).

NOTE: Do not discard bonded washer (17), it will be reused for reassembly.

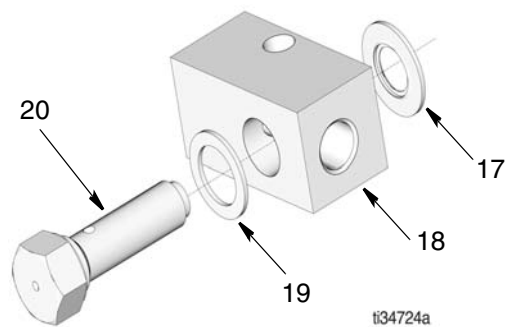

FIG. 3

8. Secure injector in a vise (FIG. 4).

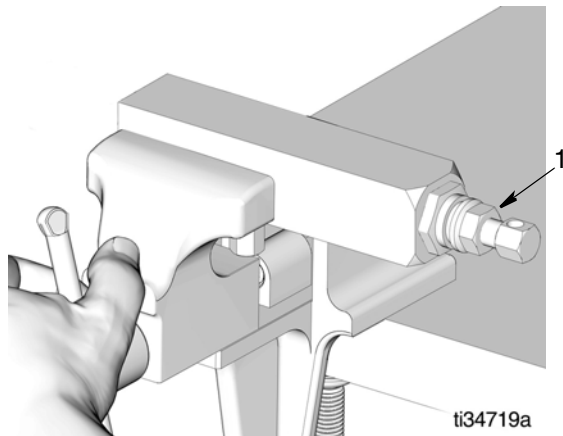

FIG. 4

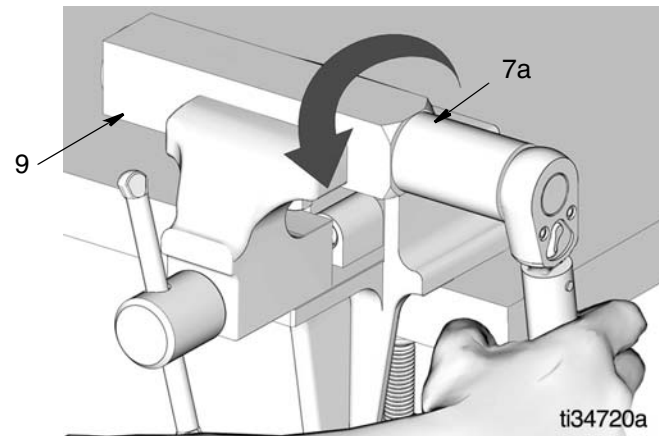

FIG. 5

11. Remove displacement piston (7) and spring (11) assembly from injector body (9) (FIG. 6).

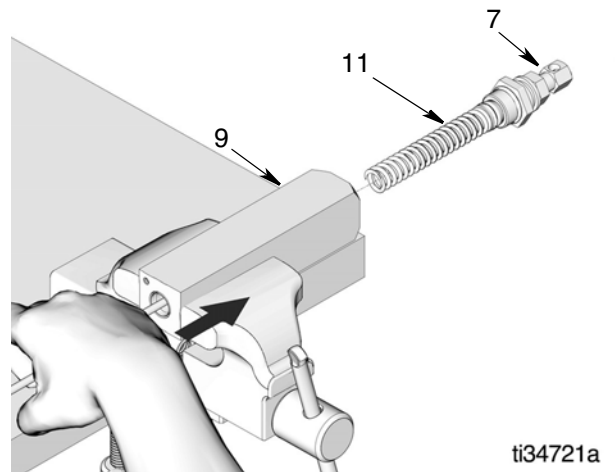





FIG. 6

 <h1 style="margin: 0;">WARNING</h1>				
				
<p>COMPRESSED SPRING HAZARD</p> <p>The internal spring is compressed. To prevent injury, always maintain control of the displacement piston while loosening it to prevent the displacement piston and spring from becoming projectiles. Wear appropriate personal protective equipment, including protective eye wear.</p>				

9. Turn adjustment screw (1) (FIG. 4) all the way out to reduce the spring tension as much as possible.

10. Use a deep well, 15/16 inch (24 mm) socket on packing hex (7a) (FIG. 5) to turn it counter-clockwise just until the piston assembly is loose enough to hand-turn.

Remove the wrench handle from the deep well socket. Continue using the socket to **slowly** hand-turn hex (7a).

NOTE: The compressed spring (11) inside the injector will begin to expand as the hex is loosened. The displacement piston (7) and spring could become projectiles if control is not maintained throughout this step.

Instructions

12. Use a dowel or long rod with a flat end to push the plunger (GL-1XL models)/poppet (GL-1X models) (12) out of the injector body (9) as shown in FIG. 7.

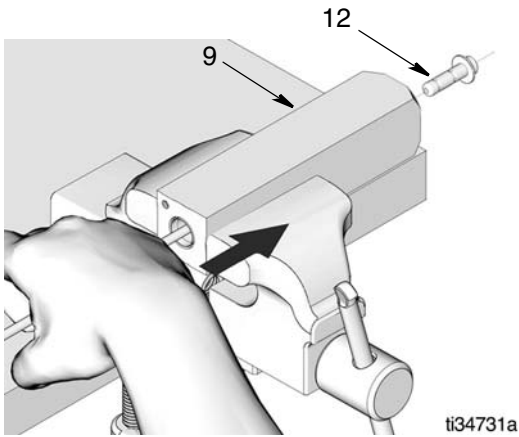

FIG. 7

13. Remove spring (11), indicator pin (8) and o-ring (4) from the displacement piston assembly (7) (FIG. 8).
14. Use a pick to remove the packing (5) from inside the displacement piston assembly (7) (FIG. 8).

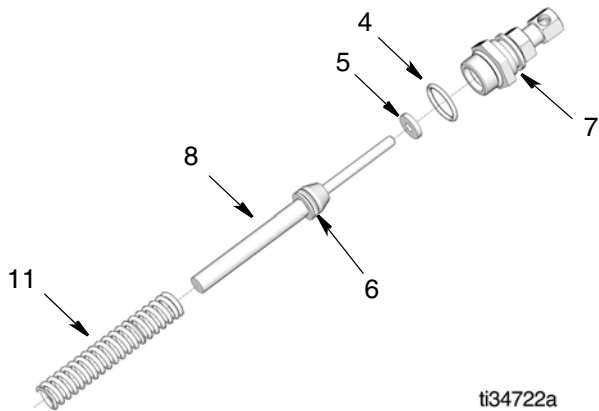

FIG. 8

15. Use a pick to remove o-ring (6) from indicator pin (8) (FIG. 9).

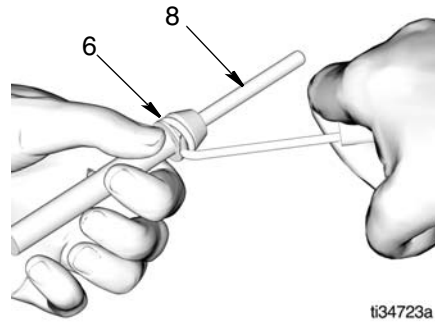

FIG. 9

16. Use a pick to remove packings (16 and 13) and inlet valve (14) from inside injector body (9) (FIG. 10).

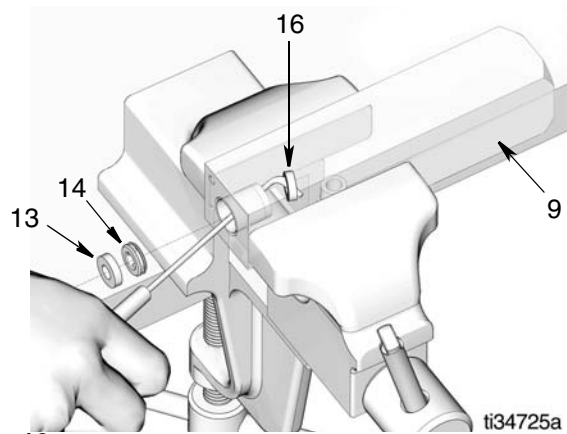

FIG. 10

Reassembly

- Always use all new parts included in the kit. Discard replaced parts according to all regulations and codes for disposal of unused parts.
- Reassemble parts in exact order shown in FIG. 11.
- Apply a thin layer of oil to all seals and o-rings prior to installation.

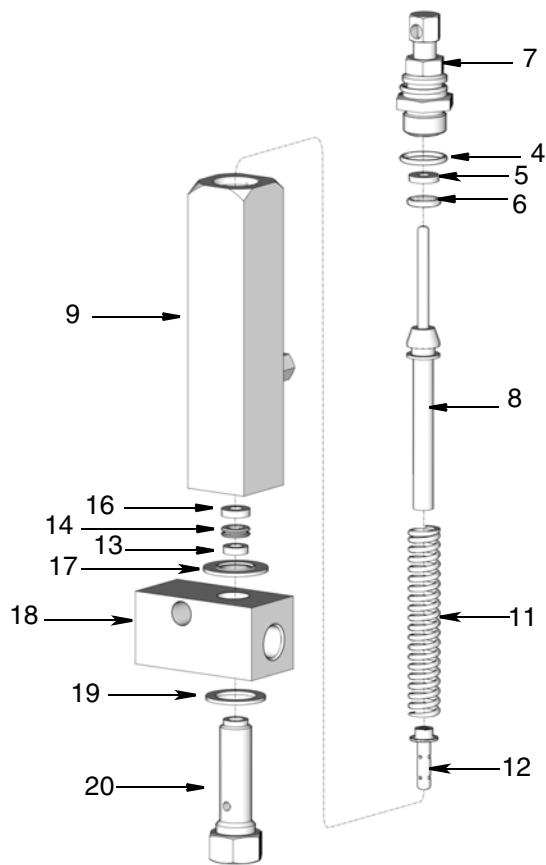

FIG. 11

1. Apply a thin layer of oil around packings (16 and 13) and inlet valve (14).
2. Install packing (16) inside injector body (9). Be sure packing is pushed all the way inside injector body.
3. Install inlet valve (14) and packing (13).

4. Slide o-ring (6) onto indicator pin (8) as shown in FIG. 12.

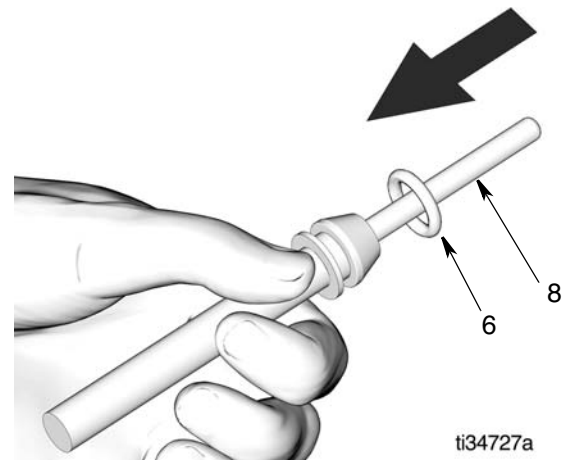

FIG. 12

5. Install packing (5) inside displacement piston (7).
6. Install o-ring (4) as shown in FIG. 13.

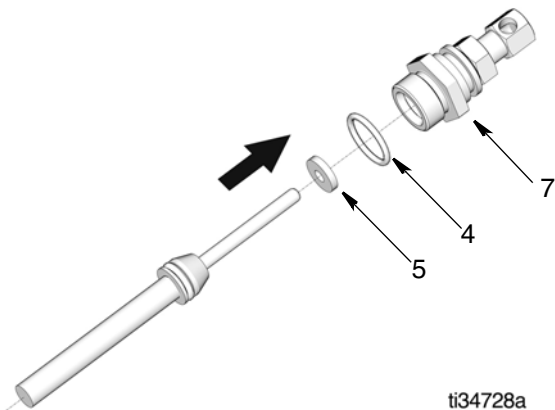

FIG. 13

7. Install indicator pin (8) in displacement piston (7) (FIG. 13).
8. Install spring (11) over the end of the indicator pin (8) (FIG. 14).
9. Install plunger/ poppet (12) into the end of the spring (11) (FIG. 14).

Instructions

10. Install displacement piston assembly (7) in injector body (9) (FIG. 14). Secure a deep well 15/16 inch (24 mm) socket over hex (7a) and turn it clockwise to tighten fitting. Torque to 70 ft-lbs (94.9 N•m).

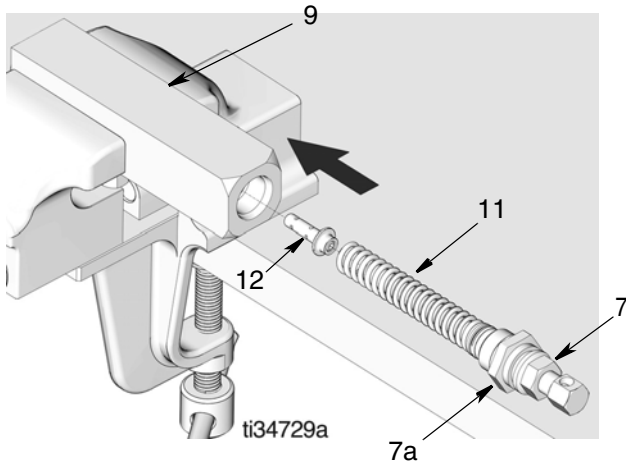

FIG. 14

11. Remove injector from vise.

NOTE: For single injector assemblies, the injector can be turned over and re-clamped in the vise as shown in FIG. 15.

12. In the order shown in FIG. 15, install steel gasket (19), manifold (18) and bonded washer (17) on bolt (20).

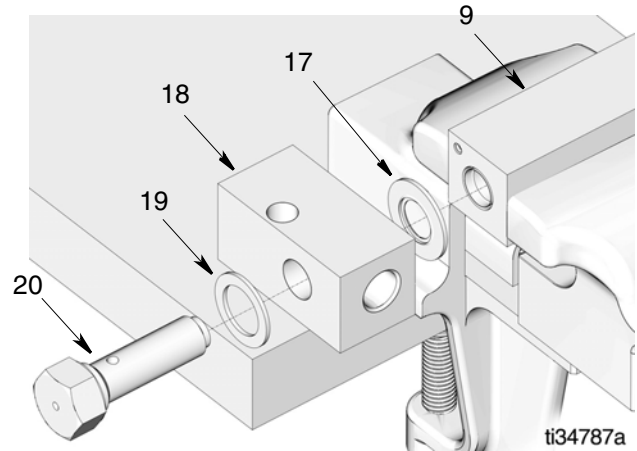

FIG. 15

13. Install the bolt (20) assembly into the injector body (9) (FIG. 15). Torque bolt to 70 ft-lbs (94.9 N•m).

Injector Installation

For installation instructions see the GL-1X and GL-1XL Injectors instruction manual 335023 provided with the injectors.

Injector Service Parts

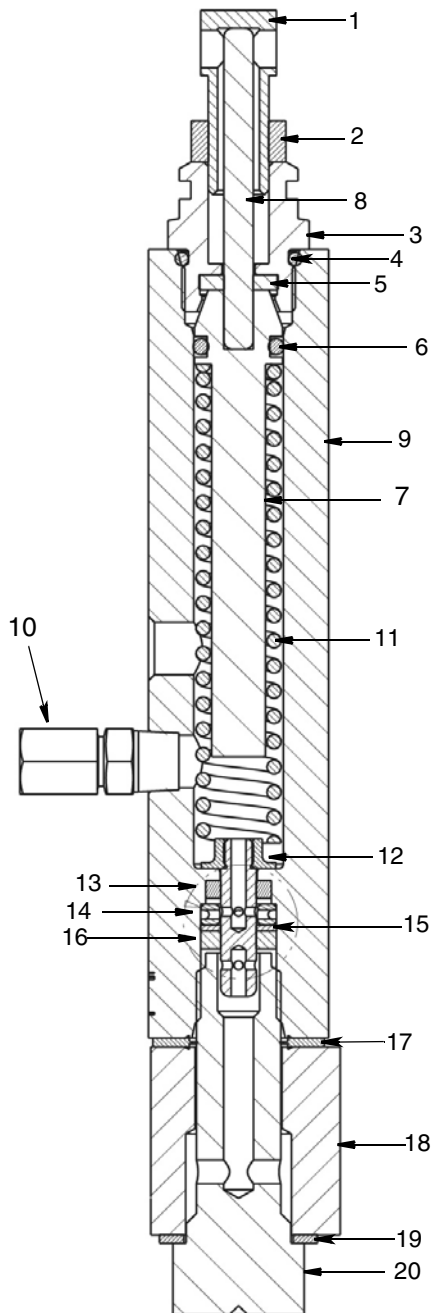

Item	Part No.	Description	Qty
1		Adjusting screw with adjusting nut	1
2		Lock nut	1
3		displacement piston	1
4		O-ring, FKM, 910 (GL-1 XL models)	1
		O-ring, FKM, 908 (GL-1 X models)	1
5	★◆	Packing, FKM	1
6	◆	O-ring, FKM, 113	1
	★	O-ring, FKM, 112	1
7		Displacement piston	1
8		Indicator pin	1
9		Injector body	1
10	114916	Zerk fitting and cap assembly	1
11	★◆	Compression spring (GL-1 XL models)	1
12	◆	Plunger with guide (GL-1 XL models)	
	★	Poppet valve (GL-1 X models)	1
13	★◆	Packing, FKM	1
14	★◆	Inlet valve	1
15	★	Backup ring, UHMWPE	1
16	★◆	Packing, FKM	1
17		Bonded washer	1
18		Manifold	1
19	★◆	Steel gasket	2
20		Adapter bolt	1

★ Included in GL-1 XL Injector Repair Kit 25A080
 ◆ Included in GL-1 X Injector Repair Kit 25A081

Technical Specifications

Maximum operating pressure	6000 psi	41 MPa, 414 bar
Suggested operating pressure	2500 psi	17 MPa, 172 bar
Reset pressure	1000 psi	6.9 MPa, 69 bar
Output volume per cycle		
GL-1 X	adjustable 0.015 to 0.08 in. ³	
GL-1 XL	adjustable 0.035 to 0.305 in. ³	
Wetted parts	carbon steel, stainless steel, fluoroelastomer, UHMWPE	
Recommended fluids	N.L.G.I. #2 grease down to 32° F (0° C)	

*All written and visual data contained in this document reflects the latest product information available at the time of publication.
Graco reserves the right to make changes at any time without notice.*

Original instructions. This manual contains English. MM3A6485

Graco Headquarters: Minneapolis

International Offices: Belgium, China, Japan, Korea

GRACO INC. AND SUBSIDIARIES • P.O. BOX 1441 • MINNEAPOLIS MN 55440-1441 • USA
Copyright 2018, Graco Inc. All Graco manufacturing locations are registered to ISO 9001.

www.graco.com
Revision A, October 2018