



# Manzel® MHH Modular Divider Valves

Available Electronic Only

**Modular, Series-Progressive,  
Divider Valve Delivers  
Positive Oil Lubrication for  
Gas Engines, Compressors  
and Similar Equipment at  
Pressures up to 6000 PSI  
and 7500 PSI**



\*MHP part numbers will automatically be superseded by the Graco GEDI order entry system.

MHH divider valves precisely proportion a volume of oil to satisfy the different requirements of every point in a lube system. They operate in sequential fashion to ensure that no point is missed. Series-Progressive design provides ready monitoring capability.

MHH divider valves are available for use with petroleum or synthetic oils and at pressures up to 7500 PSI. The modular, stackable sub-plate design provides maximum application flexibility. Accessory components are available for visual diagnostics and electrical monitoring.

## FEATURES/BENEFITS

- Use in terminating oil systems at pressures up to 7500 PSI (517 bar)
- Lubricate up to 16 points from one divider valve assembly.
- Soft-seal O-ring construction and indicator ports minimize leakage and reduce maintenance.
- Built-in check valves prevent lube back flow and help keep lube lines full.
- Stackable sub-plate design simplifies build-up, installation and maintenance.
- Ample clearance between outlet connections for elbows and 3/8" lube lines.
- Performance indicators, cycle indicators and proximity switches monitor divider valve action to simplify troubleshooting and repair.
- Choice of SAE or NPSF inlet and outlet connections
- Choice of 70 Durometer Buna-N or 90 Durometer fluoroelastomer O-rings.

## DESCRIPTION

Each MHH divider valve assembly incorporates from three to eight working piston sections (1), associated sub-plate sections which include the outlet distribution ports (2), an inlet section (3), and an end section (4).

“Twin” sections are ported to provide separate outputs from each end of a working piston and direct them to two lube points. “Single” sections are ported to combine the outputs from each end of a working piston and direct it to one lube point.

Cross port plates (5) may be installed between working piston sections and sub-plate sections to combine the outputs of successive working piston sections. (Cross port plates must not be installed beneath bottom working sections.) Singling plates (6) may be installed to combine the outputs from both ends of a working piston in any “Twin” section. Bypass sections (not shown) may be used in place of working piston sections to eliminate inactive lube lines without disturbing active lube lines, or to provide for future system expansion. (Divider assembly must contain at least three working sections in addition to bypass section.)

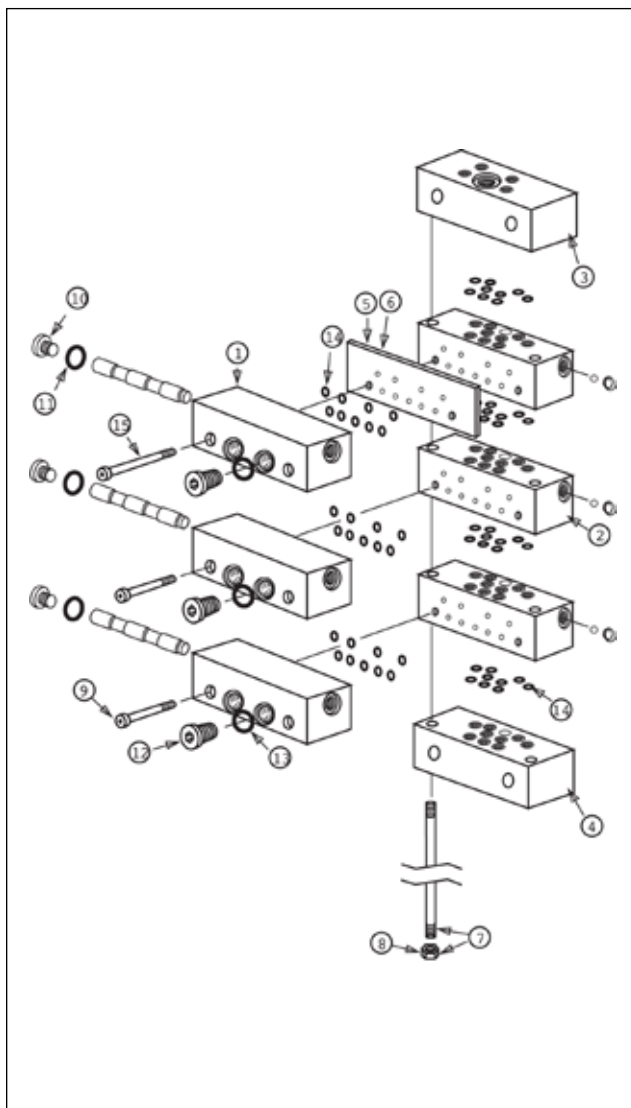

COMPONENTS										
Key	Size	Description	Output Volume		MHP valves have been superseded by MHH valves shown at right		MHH (High Pressure fluoroelastomer 90 Durometer O-Rings)		w/Cycle Pin *+ Right Hand Side	
			in3	cm3	Part No.	Old Part No.	Part No.	Old Part No.	Part No.	Old Part No.
1	6T	.006 Twin	0.006	0.098	562667	106-000-085	562685	106-000-595		
	6S	.006 Single	0.012	0.197	562661	106-000-025	562679	106-000-465		
	9T	.009 Twin	0.009	0.149	562668	106-000-095	562686	106-000-605		
	9S	.009 Single	0.018	0.295	562662	106-000-035	562680	106-000-475		
	12T	.012 Twin	0.012	0.197	562669	106-000-105	562687	106-000-615		
	12S	.012 Single	0.024	0.393	562663	106-000-045	562681	106-000-485		
	18T	.018 Twin	0.018	0.295	562670	106-000-115	562688	106-000-625	562676	106-000-235
	18S	.018 Single	0.036	0.590	562664	106-000-055	562682	106-000-495	562674	106-000-205
	24T	.024 Twin	0.024	0.393	562671	106-000-125	562689	106-000-635	562677	106-000-245
	24S	.024 Single	0.048	0.787	562665	106-000-065	562683	106-000-505	564252	106-000-215
	30T	.030 Twin	0.030	0.492	562672	106-000-135	562690	106-000-645	562678	106-000-255
	30S	.030 Single	0.060	0.983	562666	106-000-075	562684	106-000-515	562675	106-000-225
-		Bypass			562660	106-000-010				

Key	Description	Part No.	Old Part No.	Part No.	Old Part No.
		1/8-27 NPSF		7/16-20 SAE	
2	Intermediate Sub-plate*	563425	-	563451	527-003-550
		1/4-18 NPSF			
3	Inlet w/Bleed	563421	-	563422	527-000-325
4	End Section*	563424	-		
5	Cross port plate - Right+#	563469	527-005-320		
	Cross port plate - Left+#	563470	527-005-330		
	Cross port plate - Both+#	563471	527-005-340		
6	Singling Plate+#	563472	527-005-350		

**NOTE:**

\* Part numbers include standard Buna-N 70 Durometer seals for 6000 PSI maximum system pressure. Consult Graco for fluoroelastomer 90 Durometer (7500 PSI) seals.

Working piston sections are also available with cycle indicators mounted on the left-hand side, but limit maximum operating pressure to 3500 psi.

When requested, cross porting and singling can be accomplished by using appropriate plates.

+ Part numbers include appropriate mounting screws.

# Part numbers include 90 Durometer fluoroelastomer seals for 7500 PSI maximum system pressure.

Key	Description	Part No.	Old Part No.
7	Tie Rod (3 req'd)		
	3 Section	557731	527-001-930
	4 Section	557732	527-001-940
	5 Section	557733	527-001-950
	6 Section	557734	527-001-960
	7 Section	557735	527-001-970
	8 Section	557736	527-001-980
8	Tie Rod Nut Only	556371	410-440-010
9	Valve Block Mounting Screw	556513	419-140-070
10	Piston Enclosure Plug	557716	527-000-232
11	Piston Enclosure O-Ring, 70 Buna-N	556568	422-210-040
	Piston Enclosure O-Ring, 90 fluoroelastomer	556570	422-240-040
12	Indicator Port Plug	557776	527-300-840
13	Indicator Port O-Ring, 70 Buna-N	556567	422-210-030
	Indicator Port O-Ring, 90 fluoroelastomer	556569	422-240-030
14	70 Duro, Buna-N O-Ring	556540	422-010-060
	90 Duro, fluoroelastomer O-Ring	122276	-
15	Valve Block Mounting Screw for use w/cross port and Singling Plates	556514	419-140-080

**CYCLE INDICATORS**

By sensing divider valve piston movement, lube volume can be accurately monitored and controlled. A variety of mechanical and electrical cycle indicators are available for this purpose.

**DIVIDER VALVE SECTIONS WITH ATTACHED CYCLE INDICATOR PIN**



18 through 30 size MHH divider valve sections are available with a factory-installed cycle indicator pin attached to either end of the piston. The pin moves in and out one time for each complete cycle of the divider valve assembly. Application pressure is limited to 3500 PSI.

See Page 3 for part numbers. Consult Graco for part numbers of sections with pin on left-hand side and for part numbers of sections with fluoroelastomer seals.

**CYCLE INDICATOR SWITCH - FOR USE WITH DIVIDER VALVE SECTION HAVING ATTACHED CYCLE INDICATOR PIN**



Switch bracket clamps to a cycle indicator pin housing. Cycle indicator pin movement repeatedly trips an electrical (limit) switch. Switch pulses provide input to a system controller which counts them to control and verify completion of the lube cycle.

Type	Rating	Part No.	Old Part No.
SPDT	20.0A @ 125, 250 VAC 0.50A @ 125 VDC 0.25A @ 250 VDC	563272	510-599-000
DPDT	10.0A @ 125, 250 VAC 0.30A @ 125 VDC 0.15A @ 250 VDC	564357	510-577-000

**MAGNETIC VISUAL CYCLE INDICATOR**



A No-Weep Magnetic Visual Cycle Indicator can be installed in place of a piston enclosure plug on any size divider valve section. Six steel balls in a transparent sleeve follow a magnet which moves with the cycling piston. Unlike a cycle indicator pin, working section displacement is not reduced. Suitable for application at pressures up to 7500 PSI. Part number 563251 (509-932-522)

**UNIVERSAL CYCLE COUNTER - FOR USE WITH DIVIDER VALVE SECTION HAVING ATTACHED CYCLE INDICATOR PIN**



Counter housing clamps to a cycle indicator pin housing. A 6-digit mechanical counter, advanced by the movement of a divider valve cycle indicator pin, provides visual assurance that the system is functioning. Every "count" indicates one complete cycle of the divider valve assembly. Suitable for application at pressures up to 3500 PSI. Part number 563444 (527-002-410)

**REED-TYPE PROXIMITY SWITCH (OPTIONAL)**

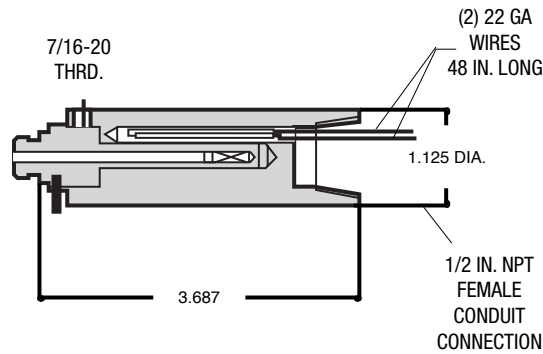

This magnetically operated SPST switch is installed in place of a piston enclosure plug. This "unattached pin" type switch can be used with any size MHH working section. An indicator type magnet follows the divider valve piston, opening and closing the switch as it moves back and forth.

SPECIFICATIONS	
<b>Material</b>	Stainless Steel, Aluminum
<b>Switch Rating</b>	1.2 Volt-Amperes; up to 115 VAC, 50 VDC
<b>Contacts</b>	Single Pole, Single Throw
<b>Ambient Temperature</b>	0° F to 130° F (-18° C to 55° C)
<b>Operating Pressure</b>	7,500 psi (max)
<b>Cycle Rate</b>	60 cpm (max)
<b>Cycle Life Expectancy</b>	10,000,000+ Cycles
<b>Part No.</b>	563427 (527-001-231)

**FIELD-SENSITIVE-MECHANICAL (FSmech)  
PROXIMITY SWITCH FOR HAZARDOUS  
ENVIRONMENTS (SUPPLIED AS STANDARD  
WITH MENU CODE OPTIONS E, F, G, M, N, P)**

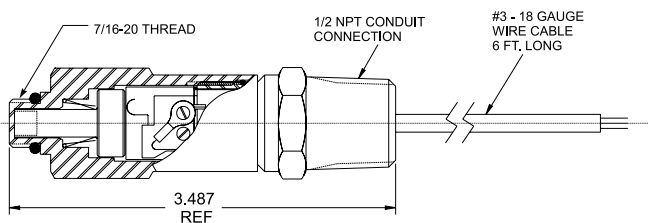

This mechanical switch is installed in place of a piston enclosure plug and is actuated by the movement of the piston.

It can be used with any size MHH working section and is suitable for use in systems operating in hazardous environments.

SPECIFICATIONS	
<b>Current Rating</b>	1.2 Volt-amps @ 28 VDC; 5A Resistive @ 115, 230 VAC
<b>Temperature Range</b>	-58° F to 167° F (-50° C to 75° C)
<b>Normally Open Contacts</b>	
<b>Cycle Rate</b>	150 cpm (max)
<b>Cycle Life Expectancy</b>	10,000,000+ Cycles
<b>Operating Pressure</b>	7,500 psi (max)
<b>CSA Certified</b>	For CL1: Groups A, B, C and D; Div. 1
<b>Part No.</b>	563485 (527-006-060)

**PERFORMANCE INDICATORS**

Performance indicators respond to the increase in pressure which occurs when lube lines or lube points become blocked. When installed in indicator ports of working piston sections, they pinpoint blockage location. Some models relieve the excessive pressure, allowing the divider valve to continue to cycle. Some models do not relieve the excessive pressure, causing the divider valve to lock up.

**Automatic Reset Relief Indicator**



A spring-loaded piston unseats when lube line blockage occurs and lubricant escapes through a vent to the atmosphere. This allows the system to continue lubricating the other unaffected points. When the blockage is cleared, the piston automatically reseats.

Relief Pressure	Part No.	Old Part No.
750 psi (52 bar)	563170	508-310-415
1,000 psi (69 bar)	563171	508-310-425
1,250 psi (86 bar)	563172	508-310-435
1,500 psi (104 bar)	563173	508-310-445
2,000 psi (138 bar)	563174	508-310-455
2,500 psi (173 bar)	563175	508-310-465
3,000 psi (207 bar)	563176	508-310-475

**Disc-Type Pressure Indicator**



A blow-out disc ruptures when lube line blockage occurs and lubricant forces a pin to protrude from the body of the indicator. There is no provision for relief and the pressure escalates until relieved elsewhere in the system. The disc must be replaced and the pin reset manually after the blockage is eliminated.

Relief Pressure	Part No.	Old Part No.
2,800 psi (193 bar)	563229	509-499-625
3,700 psi (255 bar)	563221	509-499-105
4,600 psi (317 bar)	563222	509-499-125
5,500 psi (380 bar)	563224	509-499-145
6,400 psi (441 bar)	563226	509-499-165

**Spring-Type Pressure Indicator with Memory**



When blockage occurs, a spring-loaded piston unseats and forces a separate indicator pin to protrude from the body of the indicator. There is no provision for relief, and the pressure escalates until relieved elsewhere in the system. The spring automatically reseats the piston but the indicator pin must be reset manually after the blockage is eliminated.

Relief Pressure	Part No.	Old Part No.
250 psi (17 bar)	563252	509-932-590
500 psi (35 bar)	563253	509-932-600
750 psi (52 bar)	563254	509-932-610
1,000 psi (69 bar)	563255	509-932-620
1,500 psi (103 bar)	563256	509-932-630
2,000 psi (138 bar)	563257	509-932-640
2,500 psi (173 bar)	563258	509-932-650
3,000 psi (207 bar)	563261	509-932-831
5,000 psi (345 bar)	563262	509-932-832

OUTLET CHECK VALVES				
Max Operating Pressure	Cracking Pressure	Description	Part No.	Old Part No.
<b>NPT Divider Valve Outlet Check Valves</b>				
5,000 psi	10 psi	1/8-27 M x 1/8-27 F NPFT; NPSF; Carbon Steel; Hard Seat	563195	509-350-010
	35 psi		563196	509-350-030
	120 psi		563197	509-350-120
	250 psi		563198	509-350-250
	360 psi		563051	463-001-582
7,500 psi	35-60 psi	1/8-27 M x 1/4-18 F NPFT; NPSF; Stainless Steel; Soft Seat	564325	463-001-580
<b>SAE Divider Valve Outlet Check Valves</b>				
3,500 psi	20-50 psi	7/16-20 M X 7/16-20 F; Stainless Steel; Hard Seat	-	-
7,500 psi	20-50 psi	7/16-20 M x 7/16-20 F; Stainless Steel; Soft Seat	-	463-001-585

Outlet check valves enhance system integrity by ensuring that contaminants, air or gases do not back up into the lubrication system.

**DIMENSIONS** Inches/(mm)

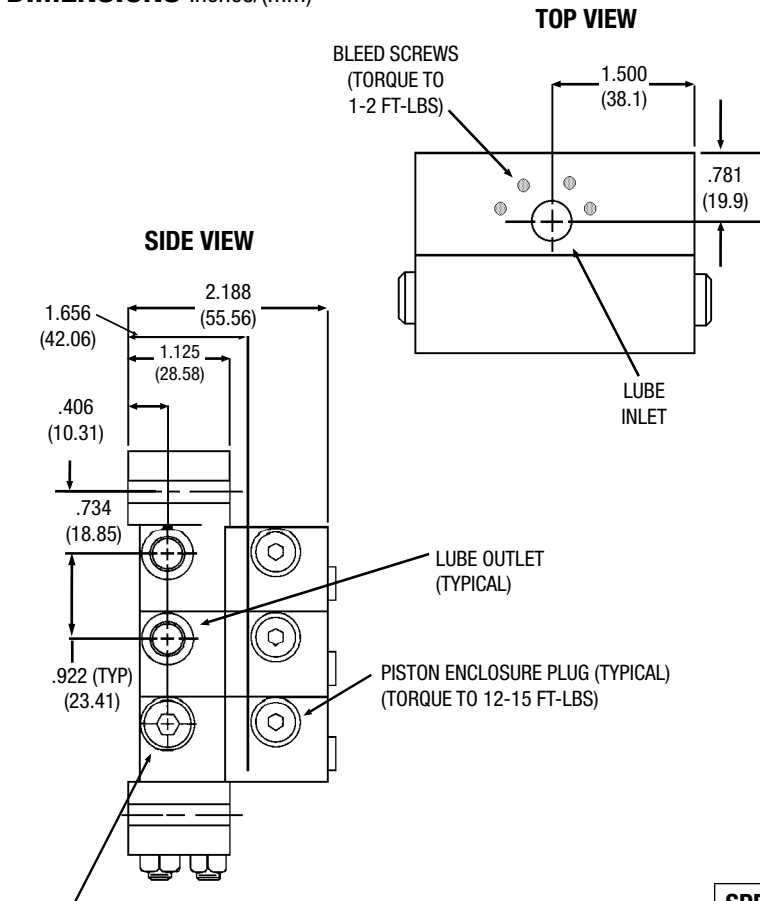

Port Sizes	
Inlet	Outlet
1/4-18 (F) NPSF	1/8-27 (F) NPSF
7/16-20 (F) SAE	7/16-20 (F) SAE

Qty of Section	"A"
3	3.578 (90.88)
4	4.500 (114.30)
5	5.422 (137.71)
6	6.344 (161.13)
7	7.266 (184.55)
8	8.188 (207.97)

OUTLET IS PLUGGED ON ONE SIDE WHEN WORKING SECTION IS SINGLED

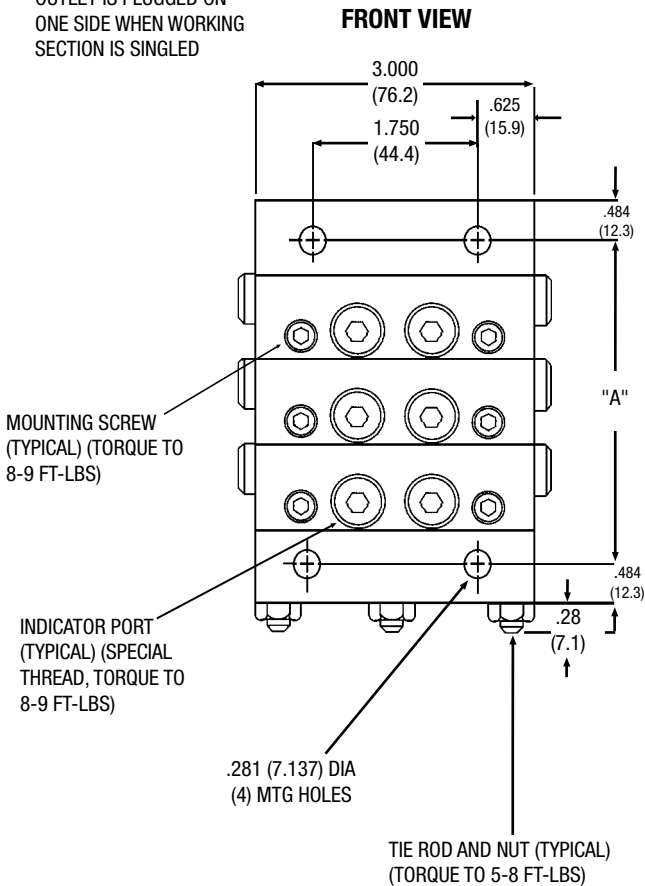

SPECIFICATIONS	
<b>Material</b>	Steel Body (Corrosion Protected) Steel Piston (Honed Fit)
<b>Lubricant</b>	Petroleum or Synthetic Oil only
<b>Max Pressure</b>	6,000 psi for Petroleum Oil only 7,500 psi for Petroleum or Synthetic Oil
<b>Max Operating Temperature</b>	Buna-N O-Rings: 200° F (93° C) Fluoroelastomer O-Rings: 350° F (163° C)
<b>Max Cycle Rate</b>	200 cpm
<b>Divider Valve Assembly</b>	Net Weight
3 Section	5.9 lb (2.7 kg)
4 Section	7.3 lb (3.3 kg)
5 Section	8.7 lb (4.0 kg)
6 Section	10.2 lb (4.6 kg)
7 Section	11.6 lb (5.6 kg)
8 Section	13.0 lb (5.9 kg)

# ORDERING INFORMATION

	XXX	-	XXX	-	X	-	X	-	XX	-	X	-	XX
<b>SERIES OF DIVIDERS</b>													
MHH - High Pressure Compressor to 7,500 psi (fluoroelastomer seals)													
<b>INLET - OUTLET THREADS</b>													
NPT - Inlet 1/4-18, Outlet 1/8-27 SAE - Inlet 7/16-20, Outlet 7/16-20													
<b>DIVIDER VALVE ACCESSORY OPTIONS (OMIT WHEN NOT REQUIRED)</b>													
P - Assembly of Performance Indicators (in all working outlets **) C - Assembly of External Check Valves (in all working outlets **) B - Assembly of Performance Indicators & Check Valves (in all working outlets **)													
<b>NUMBER OF SECTIONS</b>													
3 - Three                      6 - Six 4 - Four                      7 - Seven 5 - Five                      8 - Eight													
<b>WORKING SECTION CAPACITY</b>													
06 - 0.006 cu. in.      18 - 0.018 cu. in.      BP - Bypass 09 - 0.009 cu. in.      24 - 0.024 cu. in. 12 - 0.012 cu. in.      30 - 0.030 cu. in.													
<b>TYPE OF VALVE SECTION</b>													
T - Twin Valve                      S - Single Valve - RH Outlet                      L - Single Valve - LH Outlet B - Twin Valve w/Cycle Pin Right      C - Single Valve w/Cycle Pin Right - LH Outlet      D - Single Valve w/Cycle Pin Right - RH Outlet H - Twin w/Cycle Pin Left                      J - Single w/Cycle Pin Left - RH Outlet                      K - Single w/Cycle Pin Left- LH Outlet													
<b>CROSS PORTING OPTION (OMIT WHEN NOT REQUIRED)</b>													
CR - Right Hand Side CL - Left Hand Side CB - Both Sides													

\*\*Performance Indicator/Check Valve part number must be specified on order.

If a Proximity Switch is required, order as a separate item (see bulletin L15600).

**NOTES:**

1. Right/left hand is determined when viewing front of divider valve assembly with inlet at top.
2. Working sections are specified starting from inlet section down.
3. When valve is cross ported, its outlet is plugged and output is diverted to next valve farthest from inlet.
4. Last valve in divider assembly, farthest from inlet, cannot be cross ported.
5. When valve is a twin, both outlets in its sub-plate must be used. When valve is a single, only one outlet in its sub-plate can be used and the other must be plugged.
6. Single valve can be cross ported on one side only.
7. Cycle pins are limited to applications of 3,500 psi max.
8. Cycle pins are available on MHH 18, 24 & 30 size valves only.
9. Fsmech proximity switches can be used on all sizes of MHH working sections.
10. All divider valve assemblies must have a minimum of 3 working sections and a maximum of 8 working sections.

All written and visual data contained in this document are based on the latest product information available at the time of publication. Graco reserves the right to make changes at any time without notice.

## Contact us today!

To receive product information or talk with a Graco representative, call 800-533-9655 or visit us online at [www.graco.com](http://www.graco.com).

