

Repairing/Replacing Hard Reservoir Grease Jockey® Air Operated Pumps



Scope: This procedure is for the field repair of Grease Jockey Auto lube systems that were installed with old style reservoir arrangement. Reason for repair is the vulnerability of the reservoir to damage from over-tightening the bolts resulting in tube cracking and leakage.

Tools Required: Assorted hand wrenches for removing old reservoir and reinstalling new reservoir. Torque wrench for setting the pump cover bolt torque correctly.

PARTS REQUIRED		
Description	Part No.	Old Part No.
*Lower Tube Seal	557334	501-423-001
*Upper Tube Seal	557333	501-423-000
*Reservoir Tube	–	469-828-033
*Sleeve, Spacer Rod (3 required)	–	445-100-224
Tie Rods (3 if required)	258287	415-700-273
*Spacer (3 if required)	557965	550-402-490
Lock Washer (3 if required)	558688	421-700-928
*Mounting Clamp (3 if required)	557046	461-301-030
Strap (if required)	557878	550-050-240

*Parts included in kit 563774 (550-402-530) reservoir repair kit

Preparing pump for repair:

1. Relieve air pressure from tractor air system
2. Empty reservoir of grease.
3. Disconnect electrical connector from solenoid valve.
4. Disconnect the air line from air source.

If space is limited where pump/reservoir assembly is located on the vehicle, it may be necessary to remove it to replace reservoir. If repair can be completed with pump on the vehicle, skip to next section to complete repair.

5. Disconnect and remove the main Grease line from the pump and the Curb side module.
6. Unbolt the pump from the frame and prepare for repair.

Repair of Grease Jockey pump:

1. Remove tie rods from reservoir cover. Ignore the 200 Pound spring warning on the cover. There is no spring.
2. Remove the old reservoir tube with existing upper and lower gaskets and discard.
3. Obtain replacement reservoir tube, part number 557097 (469-828-033).

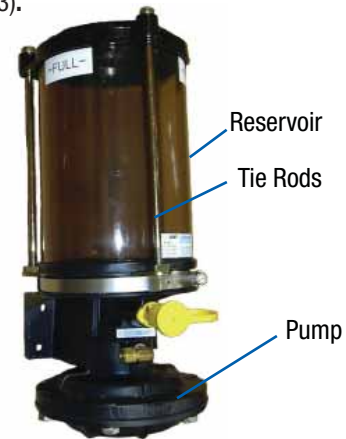

4. Install new seal, part number 557334 (501-423-001), on lower end of reservoir tube. Make sure that the tube fits in the groove in theseal. This may require some stretching to fit.
5. Install a new gasket, part number 557333 (501-423-000), on the top of the reservoir.



6. Wipe the areas where the seal and the gasket seat to remove any debris, seal fragments, or grease.

7. Place new reservoir tube with new seals onto pump base. Make sure that the tube stays in the groove of the seal and remains in place. This can be verified by running your finger around the inside diameter of the reservoir tube to feel for the inner lip of the seal.
8. Place the reservoir cap on the reservoir tube and reinstall tie rods. Use new ones as required. The tie rods will be inserted through the spacer tubes, part number – (445-100-222), supplied. The spacers will insure the top cover is parallel with the base and the reservoir tube is not compressed too tightly.
9. Hand-tighten the tie rods to take up the slack and compress the seals slightly. Using a wrench, continue tightening the tie rods sequentially around the reservoir until the spacer tubes are tight.
10. Torque bolts to **4-5 foot lbs (48-60 inch lbs)** in incremental steps sequentially around the reservoir with a minimum of 2 steps. Torque should be even at all three bolts. If a torque wrench is not available, turn the tie rods approximately ¼ turn beyond where the spacer tubes had bottomed out.
11. If pump was removed from vehicle, re-mount on vehicle.
12. Reattach all electrical connections, grease tubes, and air lines. Refill reservoir with "00" grease. See documents L00002 or L30050 for more information on grease selection.
13. System may require purging to remove air from the lines. Refer to manual for purging instructions.

Pump Exploded View Showing Replacement Components

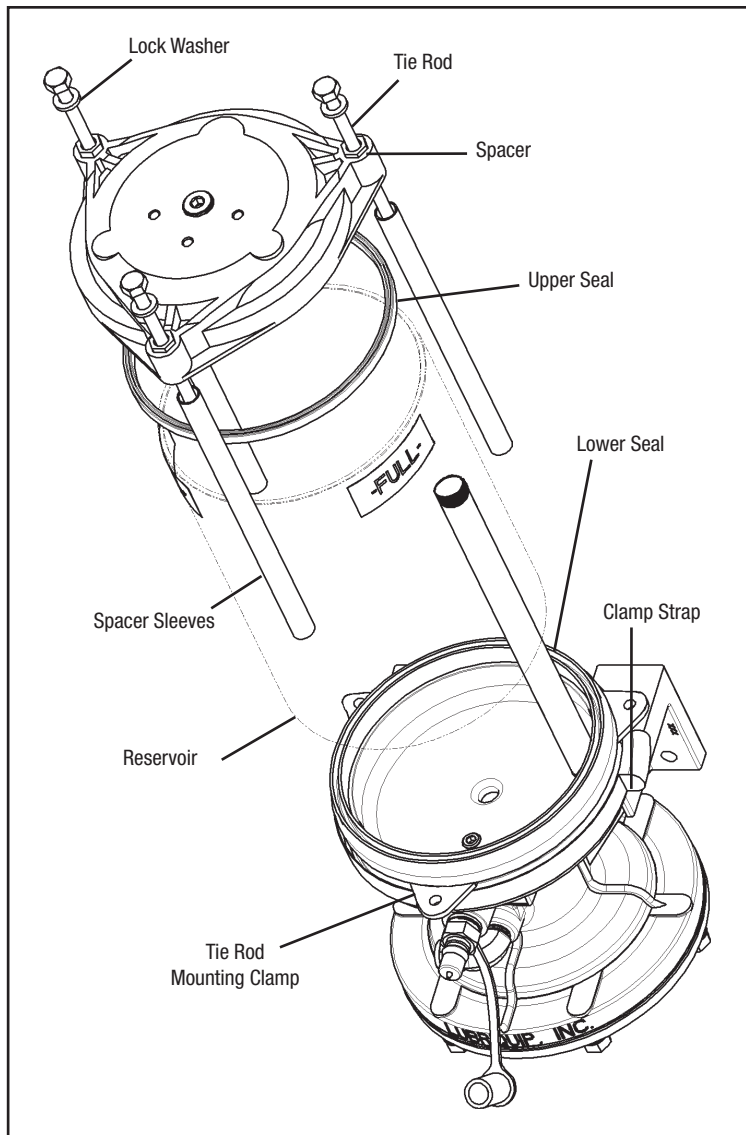

OTHER REPAIR KITS AVAILABLE

Description	Part No.	Old Part No.
Flexible Reservoir Replacement Kit	563761	550-400-780
Flexible to Rigid Reservoir Conversion Kit	563931	560-002-460

All written and visual data contained in this document are based on the latest product information available at the time of publication. Graco reserves the right to make changes at any time without notice.

Contact us today!

To receive product information or talk with a Graco representative, call 800-533-9655 or visit us online at www.graco.com.

