

# Bi-Flo<sup>®</sup> Lubrication Systems



**TRABON<sup>®</sup>**  
**PUMPING**  
**PACKAGES**  
**FEEDER VALVES**  
**REVERSERS AND**  
**ACCESSORIES**

## BI-FLO LUBRICATION SYSTEM = TRUE MODULARITY

The Bi-Flo lubrication system provides a positive method of supplying oil or grease to lubrication points from a single pumping source. The pump source feeds Bi-Flo feeder valves via two lines that are alternately pressurized. The feeder valve sections can either be plumbed directly to lube points or feed a series-progressive network, which in turn feeds the lube points. This feature makes the Bi-Flo well suited for longer systems, such as transfer lines or conveyors, and machines with a large number of lube points. Figure 1 below illustrates the major components of a typical system.

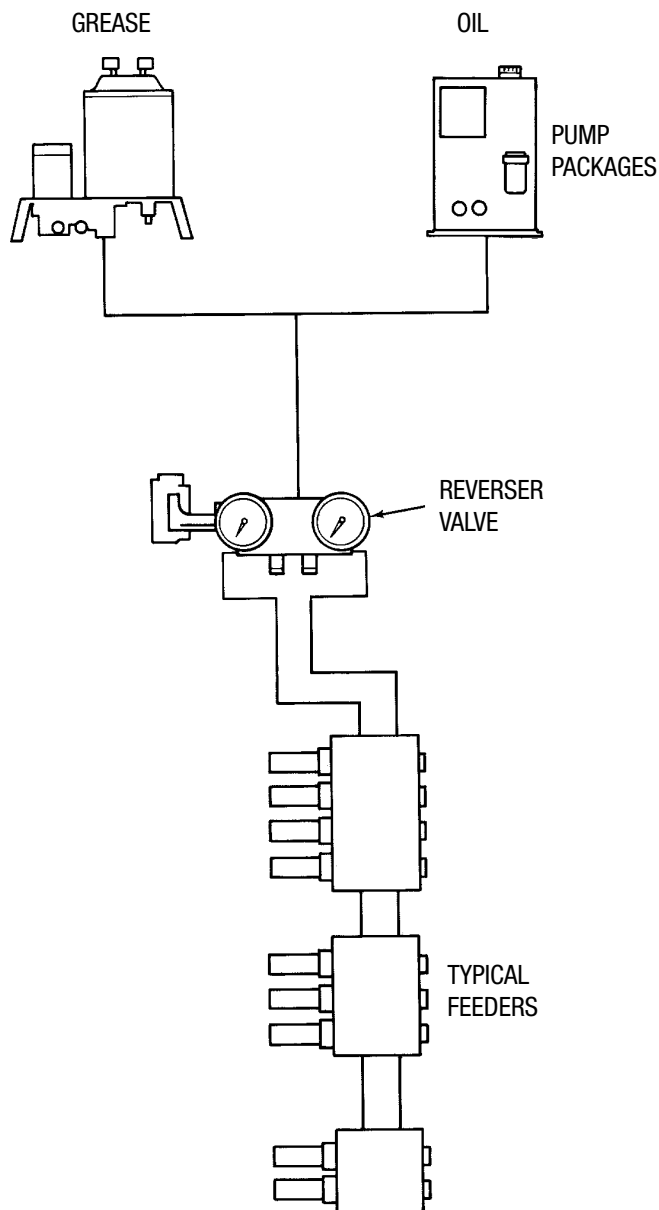

### Pump Packages:

Pump packages with a choice of reservoir sizes are available for either grease or oil. An assortment of options are available to fit various applications. For details on grease packages, see pages 3 through 7; for oil packages, see pages 8, 9 and 10.

For manual systems, use one of the PH manual pumps with two outlet valve shown in bulletin L12415.

### Reversers:

The reverser is included as part of any pump package as standard equipment. This valve may be plumbed in either of two configurations to supply the Bi-Flo feeder valves. For details, see pages 11 through 14.

### Bi-Flo Feeder Valves:

Each feeder valve assembly delivers a precise amount of lubricant to as many as eight individual lube points. Lube output is easily adjusted to fit your requirements. Feeder valves can be easily added or deleted from a system if requirements change; no modification or existing pump package or reversing valve is required. For details, see pages 15 through 18.

Figure 1. Bi-Flo Lubrication System Components

## GREASE PUMP PACKAGES

### Description

The heart of all Bi-Flo grease pump packages is the industry-proven LUBEMASTER® pump. The pump is mounted on a sturdy steel base which also provides mountings for all package components.

The Bi-Flo grease pump (Figure 2) is designed to pump grease efficiently at a wide range of pump cycle rates and pressures. Anti-friction drive bearings and simplified design improve pump operation and reliability. The broad output range and interchangeability of drive and reservoir selections make the Bi-Flo grease pump suitable for a wide range of applications. Optional high-pressure, high-level and low-level switches are available to allow for protection against excessive system pressure, reservoir overflow during automatic filling, and low reservoir level.

A high volume Lubemaster pump with a fixed output of 23.3 cu.in. (382 cm<sup>3</sup>) per minute is also available (contact factory)



Figure 2. Bi-Flo Grease Pump Package

### Features

- Adjustable output
- Broad output range
- Simplified construction
- Pump equipped with hardened steel piston in steel sleeve
- Modular components
- Driven by an electric motor through gear drive
- Reverser to supply feeders included in package

### Operation

Grease from the reservoir is forced into the cavity of the LUBEMASTER pump. When the motor is engaged, it turns the pump driveshaft which causes the pump piston to dispense a measured amount of grease with each revolution. The pump delivers grease to the reverser which directs grease to the Bi-Flo feeders.

The output of the pump package, per minute of operation, ranges from 0.28 to 8.62 cubic inches (4.6 to 141.3 cm<sup>3</sup>). This allows plenty of design range to meet a variety of applications. The range of output is available through use of different gear-reducing drive units and through the adjustment feature on the LUBEMASTER pump. For more information on the LUBEMASTER pump, refer to Literature No. L12715.

### Options

**Reservoirs.** Reservoirs are available in 20, 80 or 120 lb (9.1, 36.3 or 54.4 Kg) capacities. Metal cylinders are available for all reservoir sizes, with the 20 lb (9.1 Kg) version equipped with a level indicator feature. The 20 lb (9.1 Kg) capacity cylinder is also available in clear plastic. All reservoirs include a spring-loaded or weighted follower plate to ensure proper flow of grease to the pump.

If an overhead lubricant supply line is used at your facility, a standard reservoir may not be required. A smaller reservoir is available with a 1/2 NPSF inlet for connection to the overhead supply. Maximum inlet pressure for the overhead supply is 15 psi (1 bar). For header lines operating up to 6000 psi (414 bar) use pressure-reducing valve, part number 568078 (094730).

## Options Continued

**Drive Option.** Either 10:1 or 60:1 gear reduction units are available to drive the pump.

**Motors.** Drive motors are available in one of two voltage classes and phase arrangements. Drive motors are rated 1/2 hp (373 w) at 1725 rpm.

**Low-Level Option.** Any reservoir may be equipped with a low-level warning system. When the grease level in the reservoir is approaching the refill level, a chain or cable attached to the follower pulls an actuating rod which actuates a limit switch. The limit switch signal may be used to actuate a warning device or stop the equipment.

**High-Pressure Option.** To prevent excessive pressure, a blowout disc rated at 2350 psi (162 bar) is used. With the standard high-pressure option, the blowout disc will rupture at the high pressure and the lubricant escaping from the blown disc will provide a visual indication of failure.

High-pressure switch options are also available. On these assemblies, a tubed blowout assembly is used. The tubed blowout allows lubricant to flow from the ruptured blowout disc, through tubing up to an indicator assembly which provides a signal to an alarm or other device.

**High-Level Option.** The option is available for 80 and 120 lb (36.3 and 54.4 Kg) reservoirs. Since these reservoirs are metal, the grease level cannot be seen during filling. The high-level option consists of a limit switch mounted to the reservoir cover. As the follower plate rises during filling it pushes on an actuating rod which actuates the limit switch. The limit switch signal may be used to actuate a warning device or stop filling equipment.

SPECIFICATIONS	
<b>Pump Output (as pre-packaged unit)</b>	0.28-8.62 cu in/m (4.6-141.3 cm <sup>3</sup> /m)
<b>Hi Volume Pump Output (contact factory)</b>	23.3 cu in/m (382 cm <sup>3</sup> /m)
<b>Low-Level Switch</b>	
<b>115, 240 or 460 VAC</b>	20 amp
<b>120 VDC</b>	0.5 amp
<b>240 VDC</b>	0.25 amp
<b>High-Pressure Switch</b>	
<b>115, 240 or 460 VAC</b>	20 amp
<b>120 VDC</b>	0.5 amp
<b>240 VDC</b>	0.25 amp
<b>Pump Cycle Rate (as pre-packaged unit)</b>	28.75-175 strokes/minute
<b>Operating Temperature</b>	
<b>Plastic Reservoir</b>	35°F to 135°F (2°C to 57°C)
<b>Metal Reservoir</b>	20°F to 150°F (-7°C to 66°C)

Dimensions

**NOTE:**  
DIMENSIONS SHOWN ARE  
IN INCHES (MILLIMETERS)

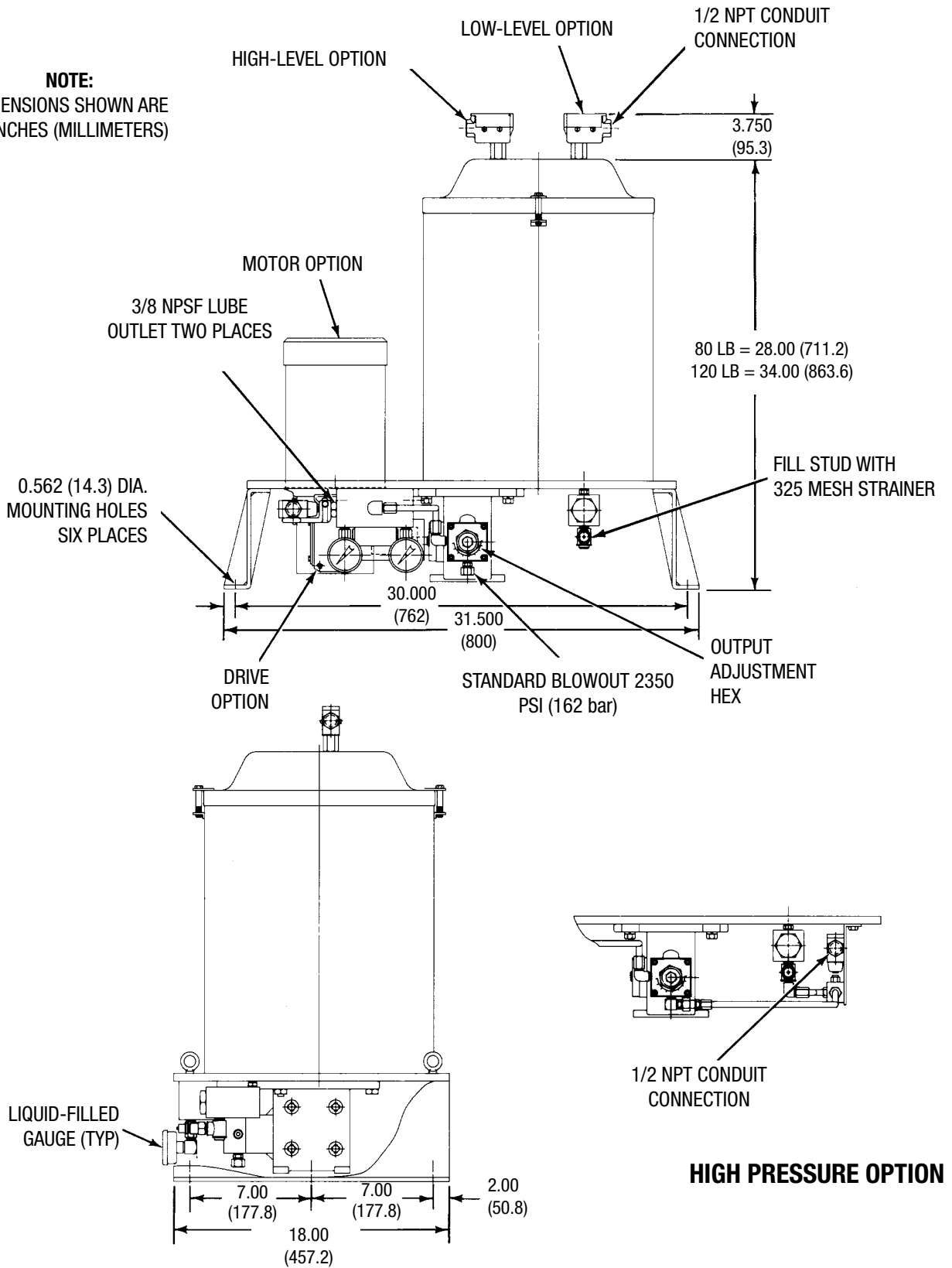

Figure 3. Bi-Flo Grease Pump Package Dimensions, Sheet 1 of 2

Dimensions - Continued

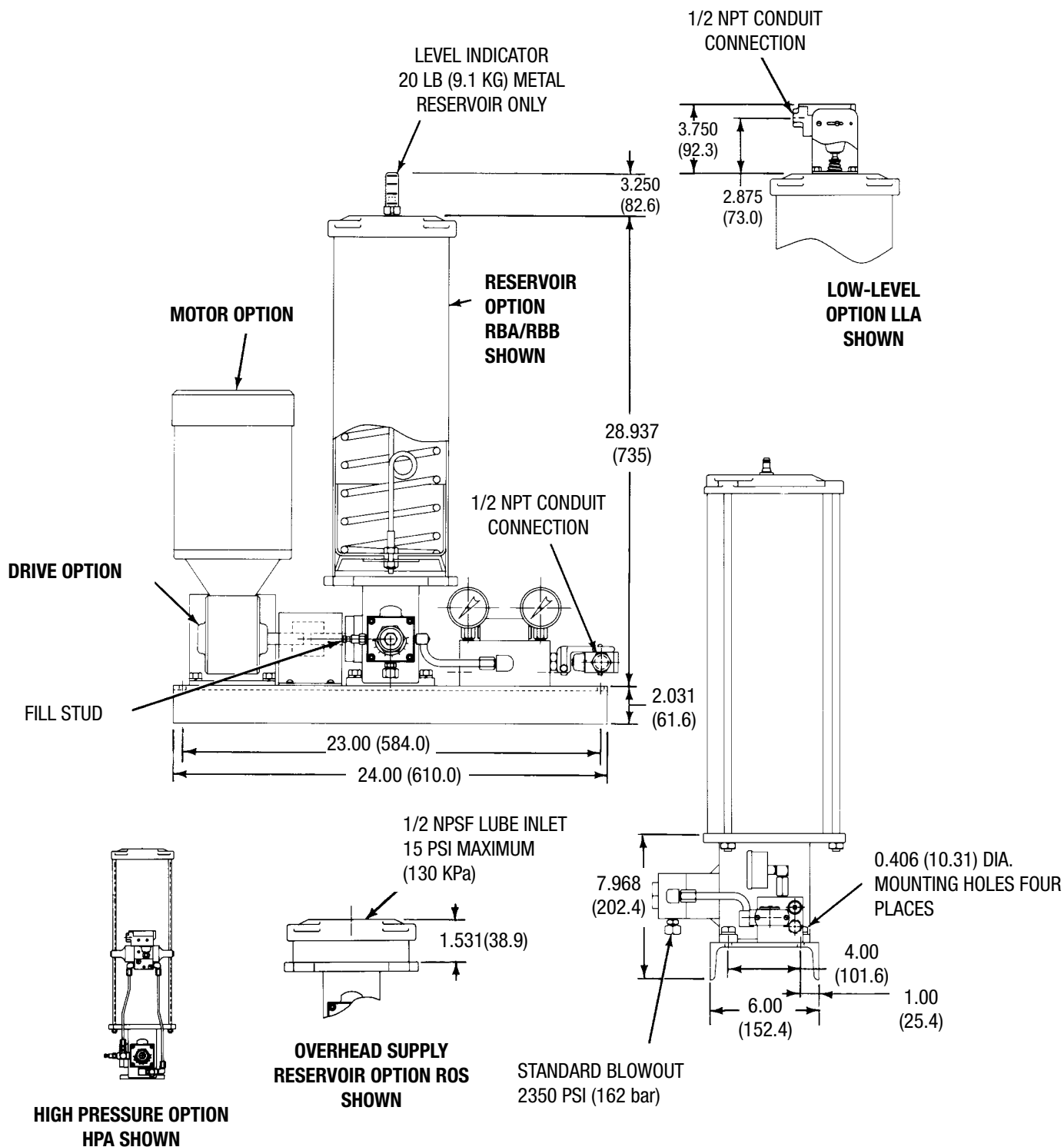

Figure 3. Bi-Flo Grease Pump Package Dimensions, Sheet 2 of 2

**GREASE PUMP PACKAGE ORDERING INFORMATION (MENU)**

BFG -	XXX	-	XXX	-	XXX	-	XXX	-	XXX	-	XXX
<b>RESERVOIR OPTION</b>											
RAA – 20 LB (9.1 kg) PLASTIC RESERVOIR											
RBB – 20 LB (9.1 kg) METAL RESERVOIR											
RBC – 80 LB (36.3 kg) METAL RESERVOIR											
RBC – 120 LB (54.4 kg) METAL RESERVOIR											
ROS – OVERHEAD SUPPLY (UP TO 12 PSI HEADER)*											
<b>DRIVE OPTION</b>											
DOA – 10:1 GEAR REDUCTION											
DOB – 60:1 GEAR REDUCTION											
<b>MOTOR OPTION</b>											
MOA – 1/2 HP, 115/230 VAC, SINGLE-PHASE, TEFC, 1725 RPM											
MOB – 1/2 HP, 230/460 VAC, THREE-PHASE, TEFC, 1725 RPM											
<b>LOW-LEVEL OPTION</b>											
LLO – NONE											
LLA – LOW-LEVEL SWITCH, 20 LB (9.1 kg) RESERVOIR											
LLB – LOW-LEVEL SWITCH, 80 LB (36.3 kg) RESERVOIR											
LLC – LOW-LEVEL SWITCH, 120 LB (54.4 kg) RESERVOIR											
<b>HIGH-PRESSURE OPTION</b>											
HPO – STANDARD BLOWOUT											
HPA – HIGH-PRESSURE SWITCH, 20 LB (9.1 kg) RESERVOIR											
HPB – HIGH-PRESSURE SWITCH, 80 LB (36.3 kg) RESERVOIR AND 120 LB (54.4 kg) RESERVOIR											
<b>HIGH-LEVEL OPTION</b>											
SOO – NONE											
SOA – HIGH-LEVEL SWITCH, 80 LB (36.3 kg) RESERVOIR AND 120 LB (54.4 kg) RESERVOIR											

\*FOR HEADER LINES OPERATING BETWEEN 16 AND 6000 PSI (1.1 AND 414 BAR), A PRESSURE REDUCING VALVE MUST BE USED TO REDUCE SUPPLY PRESSURE TO 15 PSI (1 BAR) MAXIMUM.

## OIL PUMP PACKAGES

### Description

Oil pump packages (Figure 4) use the Meterflo internal-gear pump to convey oil from the reservoir to the system components. All components are enclosed by, or attached to, a compact, floor-mounted steel housing.

Like the grease pump packages, an assortment of reservoir sizes, motors and options are available to design a pump package for your specific needs.

### Features

- Modular components
- Pump equipped with anti-friction needle bearings and hardened steel gears
- Built-in safety relief on the pump set at 1200 psi (83 bar)
- External adjustable relief valve (factory set at 1100 psi (76 bar))
- Reverser to supply feeders included in package
- Reservoir has sight glass plus pressure fill and low-level options
- 140 micron suction strainers, 10 or 25 micron filter options
- Large filler-breather cap
- Low-level switch and high-level switch

### Operation

When the motor is engaged, pump draws fluid from the reservoir and feeds it through the filter to the reverser. The reverser directs the oil to the Bi-Flo feeders.

The pump output is set at 0.12 gpm (0.45 lpm). An optional controller can be set to operate the pump for the required time period to satisfy your needs.

### Options

**Reservoirs.** Reservoirs of 15 and 30 (56.8 and 113.6 liters) gallons are available. All reservoirs are equipped with a sight glass, a low-level switch, and a 140 micron strainer as standard equipment. Access covers are available to enclose the lower portion of the reservoir where the motor, pump and reverser are located. If your application requires larger reservoir sizes, contact the factory for other options.

**Motors.** Drive motors are available in one of two voltage classes and phase arrangements. Drive motors are rated 1/2 hp (373 w) at 1725 rpm.



**Figure 4. Bi-Flo Oil Pump Packages**

**Filters.** Filters of 10 or 25 micron are available for mounting to the pump outlet. These filters are necessary to guarantee only pure oil is delivered to the reversers and Bi-Flo feeders. The outlet filters are also available with either indicators or differential gauges which indicate when the filter element needs replacement.

**Pressure Fill Option.** The pressure fill option allows oil to be supplied to the reservoir from a separate supply source. The supply source is connected to a fill stud mounted on the inlet of a 10 micron filter. After passing through the filter the oil flows directly into the reservoir.

**High-Level Option.** This option consists of a float switch positioned at the full level of the reservoir. As oil level rises during filling, the float switch is actuated. The float switch signal may be used to actuate a warning device or to stop the supply source.

**Controller.** Operation can be controlled by signals from user's machine control or by the WMP Maxi-Monitor. This microprocessor-based controller can be used to schedule and initiate cycles on a machine cycle or time basis as well as to relay fault conditions. For details, see Literature No. L14750.



SPECIFICATIONS	
Pump Output	Standard at 1725 rpm, 0.12 gpm (0.45 lpm)
Low-Level Switch	115 VAC, 10 watts
High-Level Switch	115 VAC, 20 watts
Max Temperature	221°F (105°C)
Filter Max Pressure Rating	1200 psi (83 bar)
Filter Bypass Relief Pressure	50 psi (3 bar)
Pressure Fill Filter Rating	10 micron
Pressure Line External Relief Valve	110 psi (76 bar), Relief valve may be adjusted lower

**CAUTION**

**External relief should never be set higher than 1100 psi (76 bar).**

**OIL PUMP PACKAGE ORDERING INFORMATION (MENU)**

BFO - XXX - XXX - XXX - XXX - XXX - XXX - XXX

**RESERVOIR OPTION**

RAA – 15 GAL (56.8 LITERS) RESERVOIR W/ACCESS COVER  
 RAB – 30 GAL (113.6 LITERS) RESERVOIR W/ACCESS COVER  
 RAC – 15 GAL (56.8 LITERS) RESERVOIR W/OUT ACCESS COVER  
 RAD – 30 GAL (113.6 LITERS) RESERVOIR W/OUT ACCESS COVER

**MOTOR OPTION**

MOA – 1/2 HP (373 W), 115/230 VAC, SINGLE-PHASE, TEFC  
 MOB – 1/2 HP (373 W), 230/460 VAC, THREE-PHASE, TEFC

**FILTER OPTION**

FAA – 10 MICRON FILTER  
 FAB – 10 MICRON FILTER W/GAUGES  
 FAC – 10 MICRON FILTER W/INDICATOR  
 FAD – 25 MICRON FILTER  
 FAE – 25 MICRON FILTER W/GAUGES  
 FAF – 25 MICRON FILTER W/INDICATOR

**PRESSURE FILL OPTION**

PFO – NONE  
 PFA – 10 MICRON HIGH-PRESSURE FILTER W/STUD

**HIGH-LEVEL SWITCH OPTION**

HLO – NONE  
 HLA – HIGH-LEVEL SWITCH

**CONTROLLER OPTION**

COO – NONE  
 CMA – 115 VAC MAXI-MONITOR W/MOTOR STARTER

Dimensions

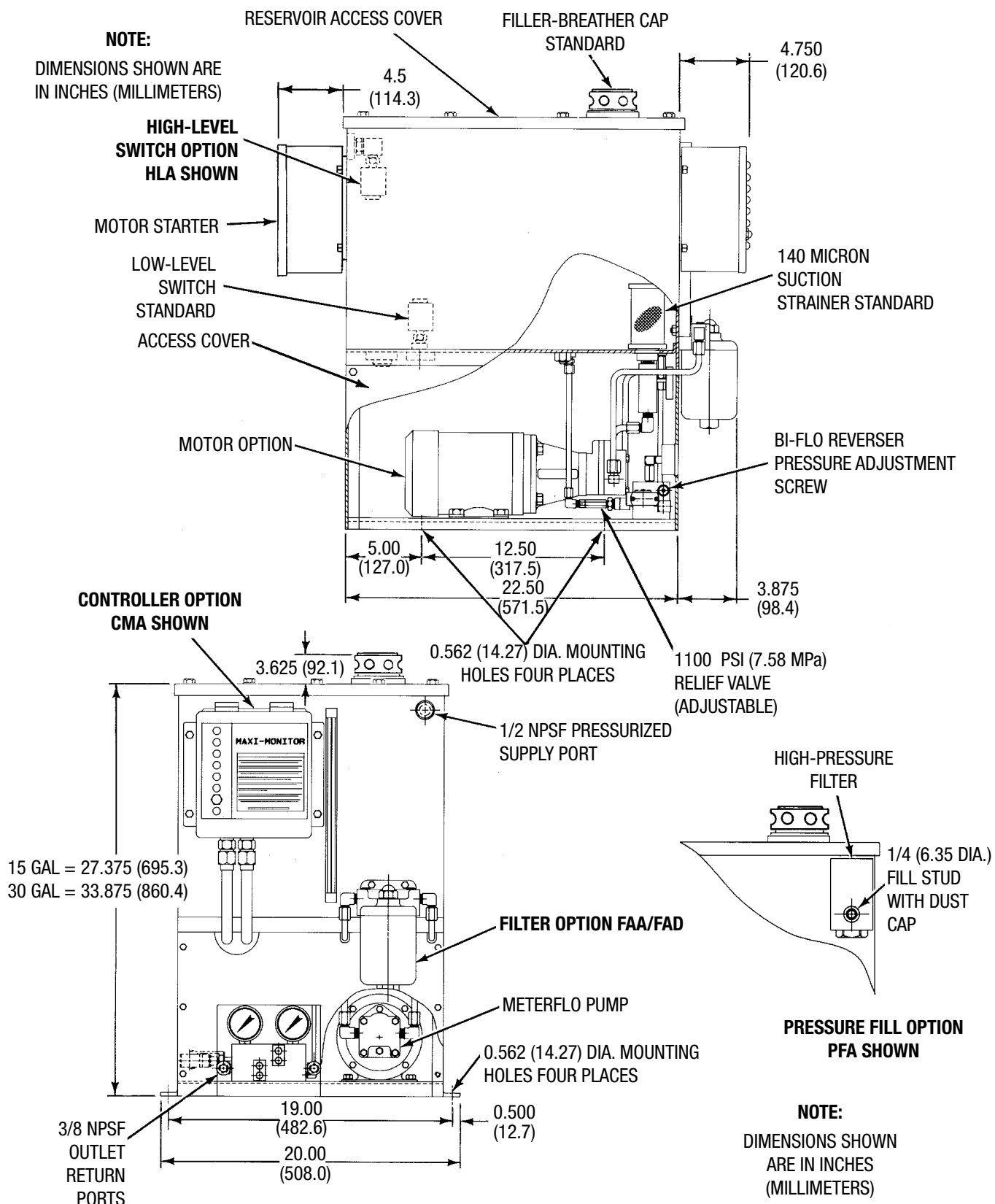

Figure 5. Bi-Flo Oil Pump Package Dimensions

**REVERSERS**

**Description**

All pump packages, whether for grease or oil, use a reversing valve. The reverser (Figure 6) houses three separate spools which are shifted to direct the flow of grease or oil to either of two outlet ports. The shifting is accomplished hydraulically by the pressure of lubricant in the system. The outlet ports direct lube to the inlet ports on the Bi-Flo feeders. When the feeders have all cycled completely, pressure rises and internal relief valve opens to allow lubricant to flow through internal ports to shift the valve spools, directing lubricant to the other outlet port.

A cycle switch attached to the reverser provides an electrical signal when a lube cycle has been completed. This signal can be used, in conjunction with a control panel, to shut down the pump or to verify system operation. Two gauges on the reverser continuously monitor system operating pressure and flow direction. The reverser is included with all pumping packages.

**Operation**

Figure 7 shows a schematic to assist in understanding the reverser operation. Ports are identified with letters A, B, G, P and T, typical of a hydraulic four-way valve. The pump feeds lubricant to the inlet port of the reverser. The internal spools are positioned to allow the lubricant to flow through one of the outlet ports. The outlet port supplies lubricant to one inlet port of each Bi-Flo feeder used. When all feeders have received lubricant and completed their cycles, the pressure builds to a point where it opens a relief valve in the reverser. The open valve allows the incoming lubricant to cycle the internal spools. The cycling of the spools results in lubricant being directed to the other outlet port. Fluid from this port is directed to the second port on the feeders. When all feeders have received lubricant, pressure in the line builds to a point where it opens another relief valve in the reverser, shifting the spools back to direct fluid to the first outlet port. This completes one cycle of the valve. A cycle pin attached to one of the internal spools actuates a switch to provide a “cycle complete” signal to the system controller.



**Figure 6. Reverser**

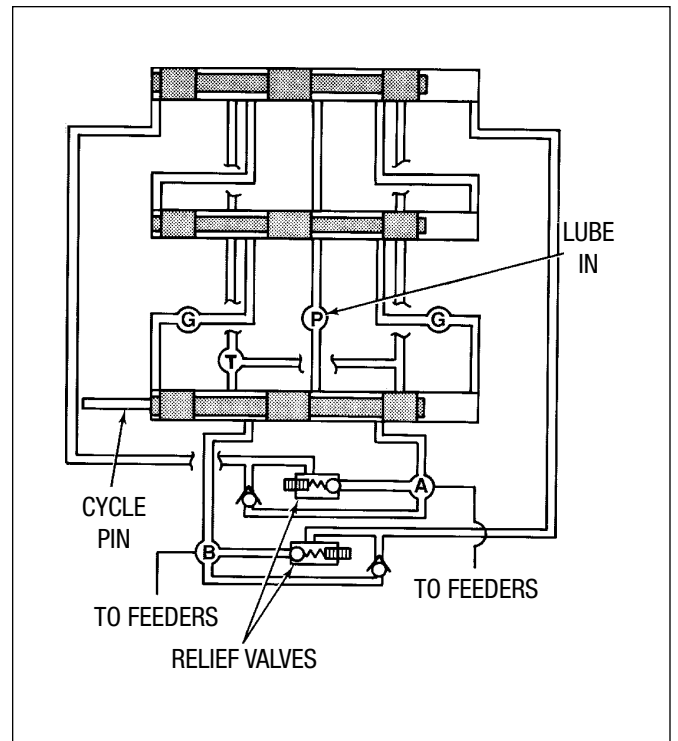

**Figure 7. Reverser Schematic**

### Configuration

Any reverser may be configured as a loop-type or end-of-line type. The valve operates on the same principle in either configuration. The configuration used depends on the application and ease of plumbing. Figure 8 represents the two configurations. In a loop-type system, two main supply lines reach all Bi-Flo feeder valves before returning to the Bi-Flo reverser, forming a two-line loop as shown below. Location of the reverser at the return end of the main supply line forces lubricant to traverse the entire system and develop sufficient pressure to operate all Bi-Flo feeder valves before the reverser is shifted to redirect flow into the other main line. In a non return system, two main supply lines feed the Bi-Flo

feeders and then dead end as indicated below. Since the reverser senses mainline pressure build up at its outlet ports, the pressure setting must be sufficiently high to insure that all Bi-Flo feeders have cycled before the reverser shifts redirecting flow to the other mainline. The pressure at which the reverser shifts is factory-set at 1000 psi (69 bar). Adjustment screws on each side of the valve allow the shift pressure to be adjusted for the specific application.

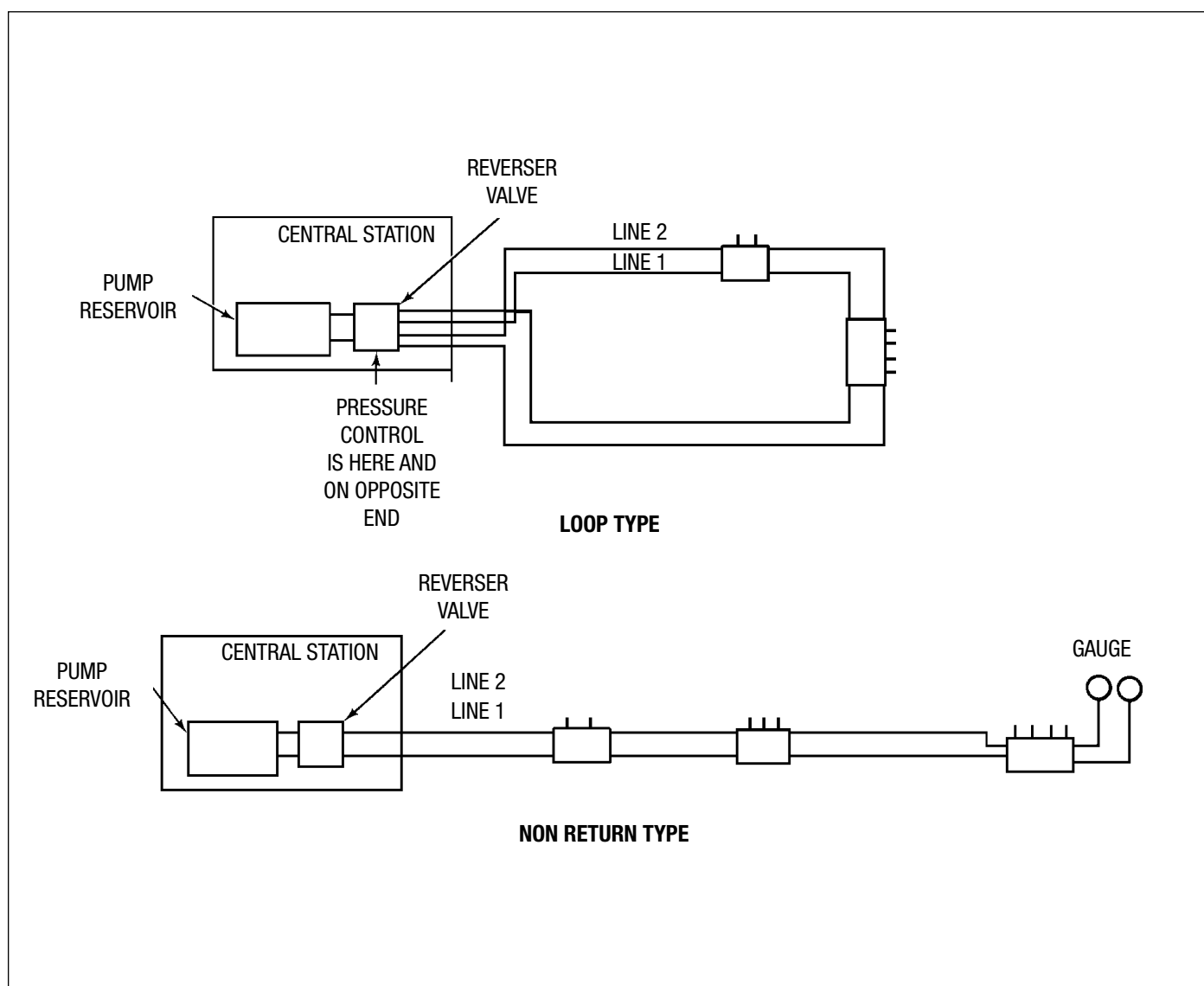

Figure 8. Reverser Configurations

The non return configuration is used mainly when the lubrication points are located over a long distance, such as a transfer line. The loop-type configuration is used when the reverser is centrally located to the lube points. No matter which configuration is used, all points will receive the correct amount of lubricant.

The reverser is shipped in the non return configuration but is easily converted to the loop-type configuration. Conversion requires the removal of the manifold bars and plugging of two holes, as shown in Figure 9. The remaining two holes (return ports A & B) are then used for the return lines.

**Note:** When configured for loop operation, line "A" out must return to "A" and Line "B" out to return to "B".

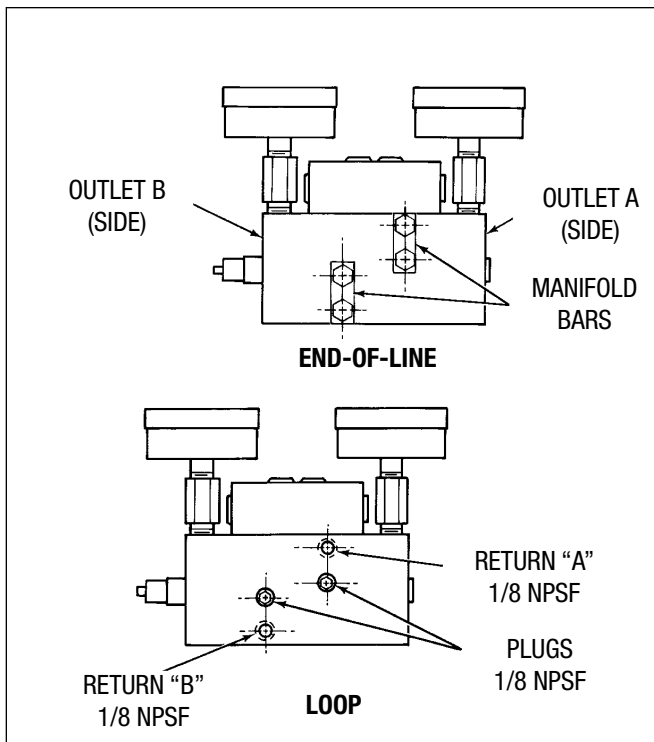

Figure 9. Reverser Conversion

SPECIFICATIONS	
<b>Reverser Ports</b>	
<b>Inlet Threads</b>	1/2-14 NPSF
<b>Outlet Port Threads</b>	3.8-18 NPSF
<b>Return to Tank Threads</b>	1/4-18 NPSF
<b>Return Ports (loop-type configuration)</b>	1/8-27 NPSF
<b>Cycle Switch Assembly</b>	
<b>115, 240 &amp; 460 VAC</b>	20 amp
<b>152 VDC</b>	0.5 amp
<b>250 VDC</b>	2.5 amp
<b>Reverser Pressure Setting</b>	
<b>Min</b>	500 psi (35 bar)
<b>Factory Setting</b>	1000 psi (69 bar)
<b>Max</b>	3000 psi (207 bar)
Turn adjustment screw clockwise (CW) to increase reversing pressure and counterclockwise (CCW) to decrease reversing pressure. Outlet "A" adjustment is on left side and outlet "B" adjustment is on right side.	

ORDERING INFORMATION		
Description	Part No.	Old Part No.
Replacement Oil	564061	520-353-000
Replacement Grease	564062	520-353-001

Dimensions

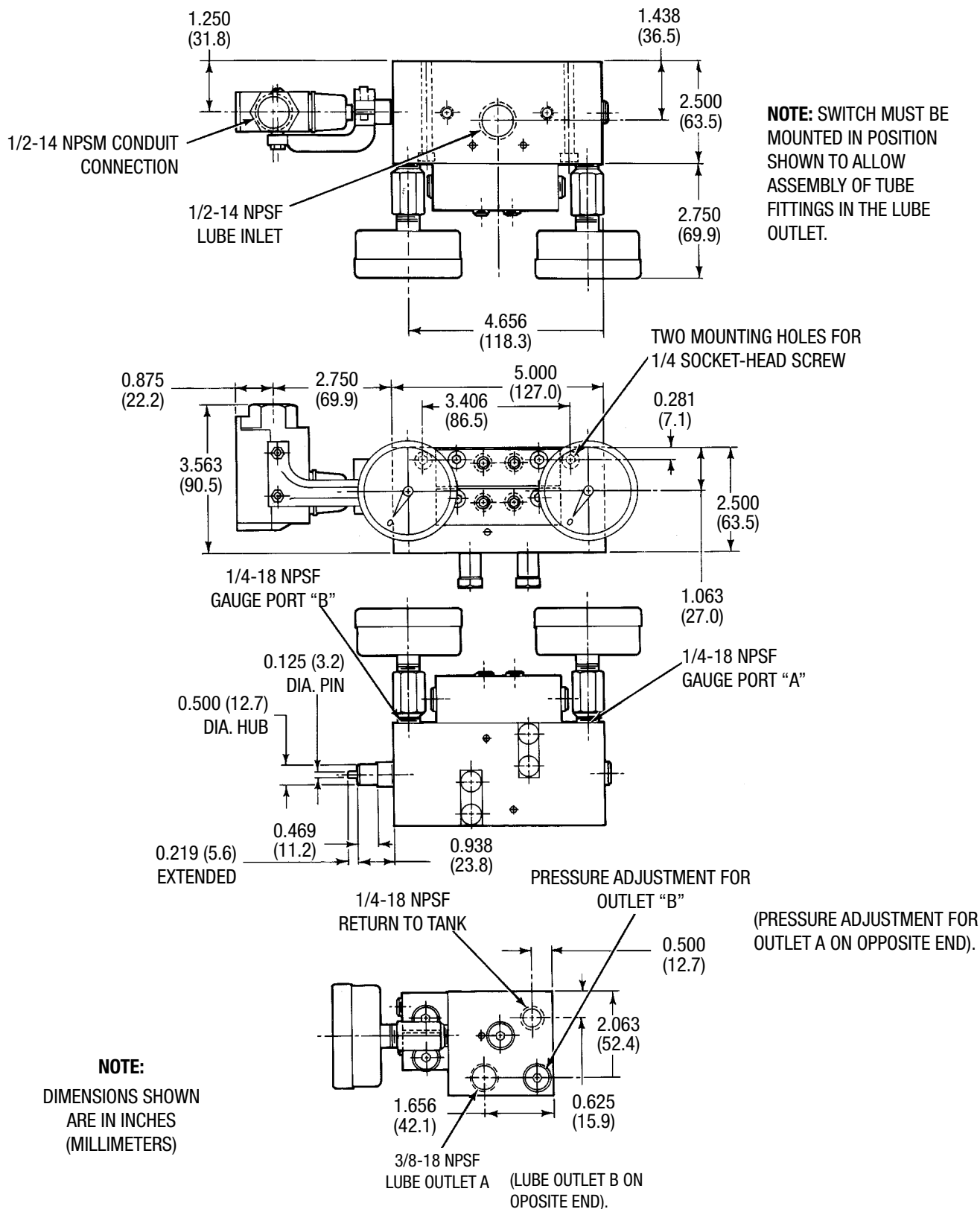

Figure 10. Reverser Dimensions

## BI-FLO FEEDERS

### Description

Bi-Flo feeders (Figure 11) can be used for grease or oil applications. The feeders are offered with two, four, six or eight outlets. Each pair of outlets is supplied lubricant by a single lube piston. The outlets then direct lubricant to the appropriate lubricant point. If required, a feeder can be easily changed to a configuration which results in a lube piston providing oil to a single outlet. A six outlet feeder, for instance, can be converted to serve either five, four or three lubrication points.

Bi-Flo feeders are available in two basic output capacities referred to as Models BB-20 or BB-50 (see specifications).

Lubricant discharges are individually adjustable for each pair of outlets by simply raising or lowering an adjustment screw. Bi-Flo feeders are equipped with pipe taps at all inlets and outlets.



Figure 11.  
Bi-Flo Feeder

### Features

- Compact, all-steel construction
- Two available output ranges
- Easily adjusted outputs
- Indicator pins to provide positive proof of system operation
- Convertible from twin outlet to single outlet

### Operation

The basic construction of a typical Model BB-50 feeder is shown in Figure 12. The construction and operation of the Model BB-20 is similar. The feeder consists of a valving piston and a lubricant discharge piston. Both slide between fixed stops.

During feeder operation, pressurized lubricant from the system reverser enters the feeder at port (A) and forces the valving piston (1) down, allowing pressure to be applied to the top of the lube

piston (2). Moving down under pressure, the lube piston forces lubricant out of its chamber (3), through the valving piston and outlet (C) to the lubrication point. During this half-cycle of the feeder, the upper chamber of the lube piston was primed for the next feeder operation.

When all feeders have completed the half-cycle, pressure builds at the reverser causing the reverser to shift and direct pressurized lubricant to feeder port (B). The valving piston is forced up allowing pressure to be applied to the bottom of the lube piston. This piston moves up and forces lubricant out of its chamber (4). The lubricant travels past the upper outlet port (D), to the lubrication point.

When the feeder is converted to single operation, twin discharge plug (Item 5) is removed and replaced with single discharge plug (Item 6). One of the discharge ports for the singled valve is also plugged. This results in the lubricant on both strokes being discharged through a single outlet to a single lubrication pint.

The head of the twin discharge plug has a hex drive socket and a slot. The single discharge plug has only the hex drive socket. This allows a visual determination of how the feeder is configured.

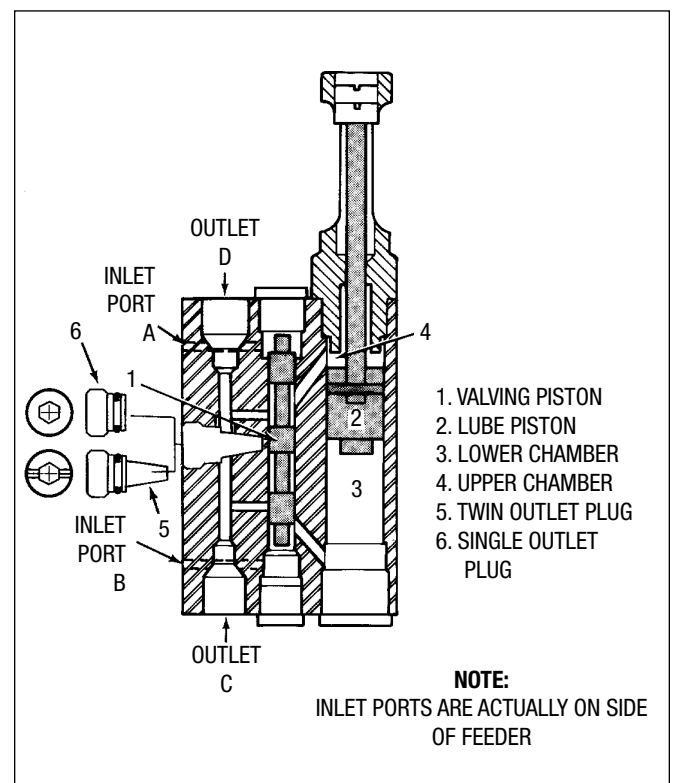

Figure 12. Model BB-50 Feeder

### Feeder Adjustment

Feeder output may be adjusted by changing the depth of an adjustment screw in the feeder valve gland. As the adjustment screw is screwed further into the valve gland, it limits the overall stroke of the lube piston, resulting in less lube being dispensed. Figure 14 shows the adjustment portion of a Series BB-50 feeder. The BB-50 series has a locking screw which must be removed to gain access to the adjustment screw. The locking screw is not present on the BB-20 series. Tables 1 and 2 provide overall range of feeder volumes and data relating to volume changes per adjustment screw movement.

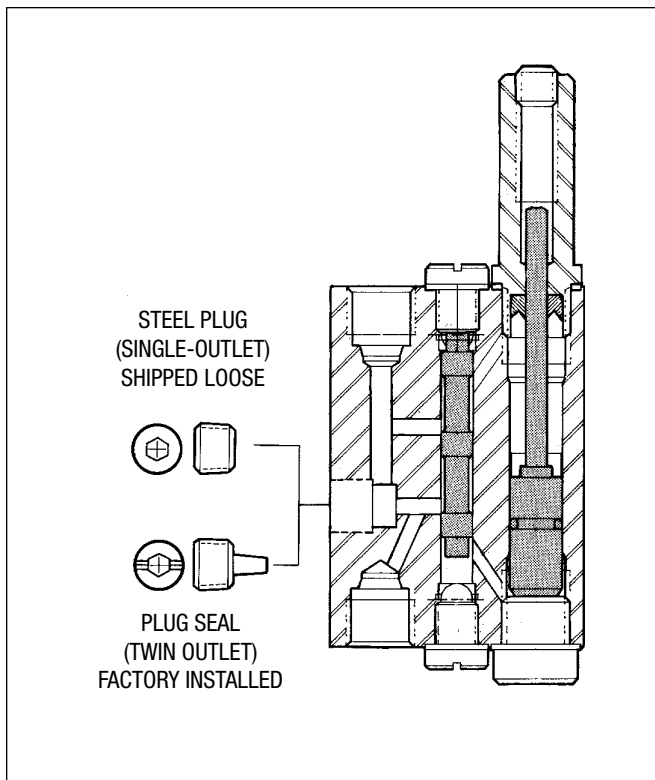

Figure 13. Model BB-20 Feeder

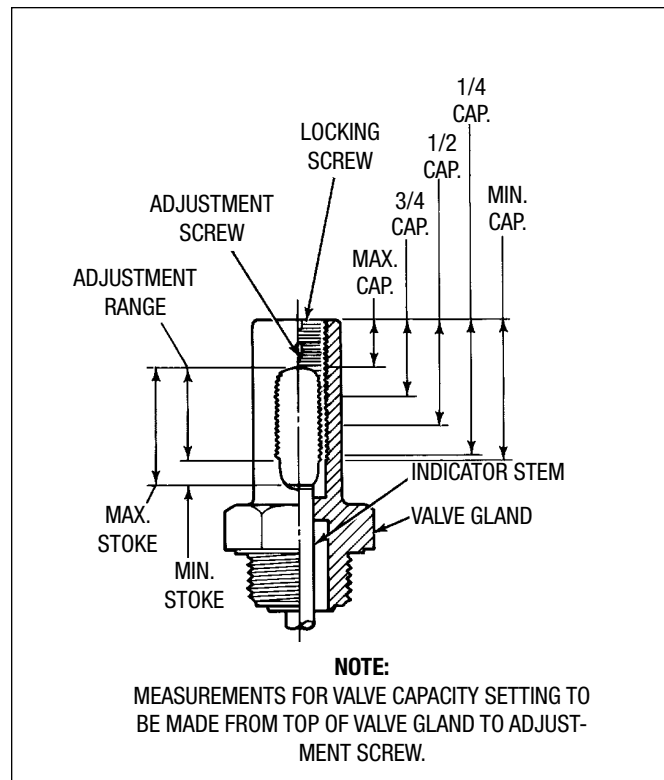

Figure 14. Feeder Adjustment



**Table 1. Output Volume Changes with Adjustment Screw Movement**

Valve Model	No. Of Revolutions Of Adjustments Screw In Range	Discharge Change Per Adjustment Screw Revolution*			Total Adjustment Range-Inches (Mm)	Approximate Adjustment Length To Change Feeder Capacity Outputs-Inches (Mm)				
		cu. in.	oz	cu. cm.		Max.	3/4	1/2	1/4	Min.
BB-20	19.25	0.003	0.0016	0.049	.687 (17.45)	.187 (4.75)	.359 (9.12)	.531 (13.49)	.702 (17.83)	.874 (22.20)
BB-20S	19.25	0.006	0.0033	0.098	.687 (17.45)	.187 (4.75)	.359 (9.12)	.531 (13.49)	.702 (17.83)	.874 (22.20)
BB-50	22.50	0.012	0.007	0.197	1.125 (28.25)	.375 (9.52)	.656 (16.66)	.937 (23.80)	1.219 (30.96)	1.562 (39.67)
BB-50S	22.50	0.024	0.013	0.393	1.125 (28.25)	.375 (9.52)	.656 (16.66)	.937 (23.80)	1.219 (30.96)	1.562 (39.67)

\*These feeders are not designed to be shut off with the adjustable screw.

**Table 2. Feeder Discharge Range**

Valve Model	Discharges Per Piston Stroke					
	Cubic Inches		Fluid Ounces		Cubic cm	
	Min	Max	Min	Max	Min	Max
BB-20	0.006	0.052	0.003	0.029	0.098	0.852
BB-20S	0.012	0.104	0.006	0.058	0.197	1.705
BB-50	0.036	0.315	0.020	0.175	0.590	5.163
BB-50S	0.072	0.630	0.040	0.349	1.180	10.326

SPECIFICATIONS	
<b>Model BB-20</b>	
<b>Lube Supply/Return Threads</b>	1/8-27 NPSF
<b>Lube Outlet Threads</b>	1/8-27 NPSF
<b>Output Per Section</b>	0.006-0.052 cu in (0.098-0.852 cm <sup>3</sup> )
<b>Model BB-50</b>	
<b>Lube Supply/Return Threads</b>	3/8-18 NPSF
<b>Lube Outlet Threads</b>	1/4-18 NPSF
<b>Output Per Section</b>	0.036-0.315 cu in (0.590-5.163 cm <sup>3</sup> )
<b>Max Pressure</b>	3000 psi (207 bar)

ORDERING INFORMATION		
Description	Part No.	Old Part No.
BB-22	563999	100-000-601
BB-24	564000	100-000-611
BB-26	564001	100-000-621
BB-28	564002	100-000-631
BB-52	563995	100-000-216
BB-54	563996	100-000-226
BB-56	563997	100-000-236
BB-58	563998	100-000-246

**NOTE:**

Single plugs for conversion from double to single discharge are furnished with feeder. One plug is needed for each singled output. A pipe plug is installed in the unused outlet port and is ordered as a separate item.

For BB-20 series order 1/8-NPT plug 557349 (503-485-000).

For BB-50 series order 1/4-NPT plug 559027 (508-976-000).

Dimensions

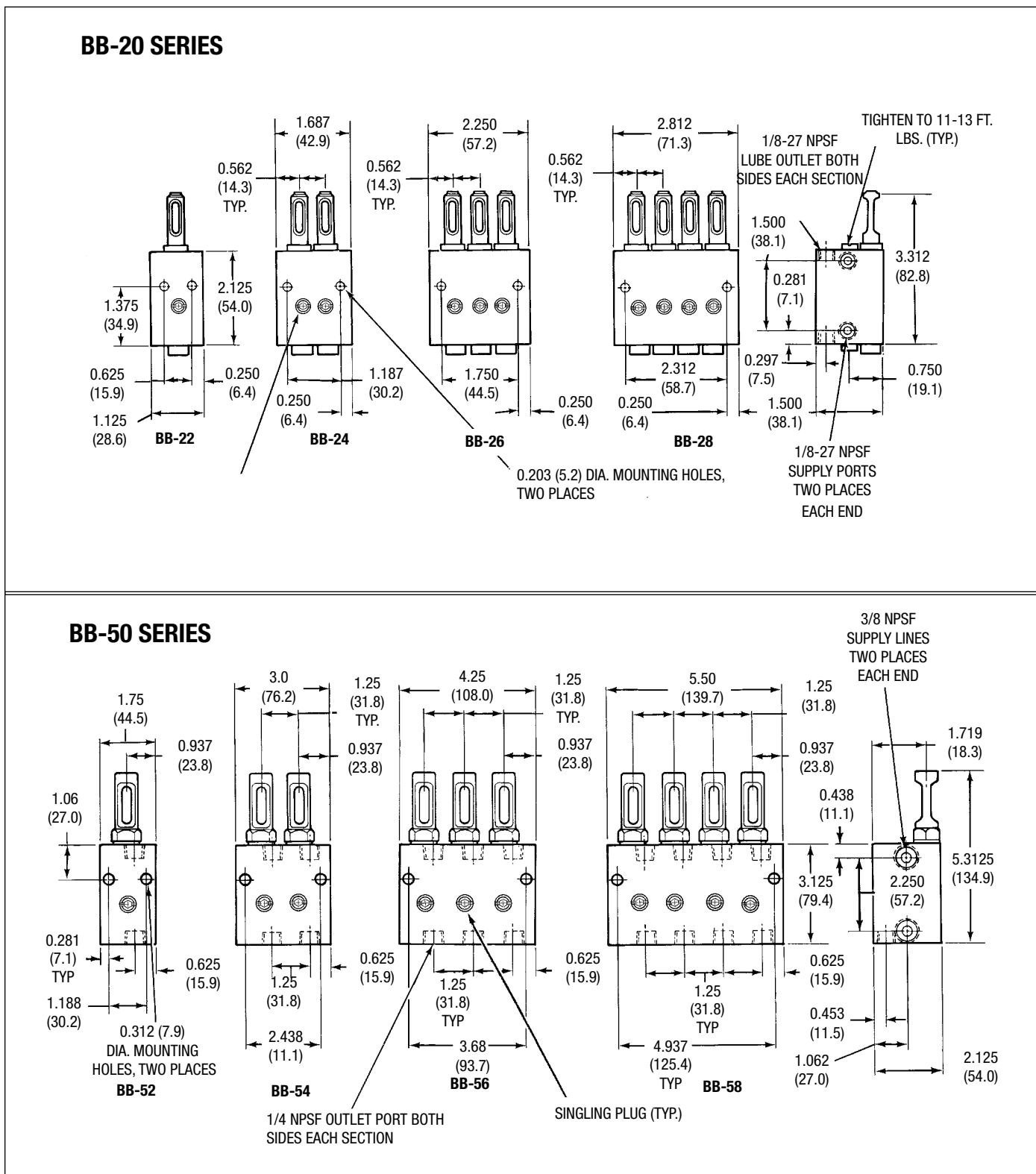

Figure 15. Feeder Valve Dimensions

## ACCESSORIES

**Two-Way Check Valve.** A two-way check valve is available for installation into the lube lines. The check valve prevents excess lubricant from draining from the lines when service requires the lines be disconnected. Two-way check valves should be mounted at the reverser valve outlet ports A and B (one per port), for both loop and end-of-line type systems. Also, when a loop type system is used, standard one-way check valves should be used on the return ports. Order part number 563199 (509-355-010) for one-way check valves. Order part number 563066 (463-300-180) for two-way check valves.



Figure 16. Two-Way Check Valve

**Outlet Check Valves.** Outlet check valves (Figure 17) are available for installation in the outlet ports of both BB-20 and BB-50 feeder valves. It is recommended that outlet check valves be used whenever possible to assist in maintaining system pressure and ensuring proper lubrication. The inlet of the check valves thread directly into the feeder valve outlet, while the check valve outlet is specially designed to accept either a standard pipe thread or a special tube fitting. Correct part number to order depends on whether special tube fittings are also used.



Figure 17. Outlet Check Valve

**Special Tube Fittings.** To reduce the hardware required to install a system, special tube fittings (Figure 18) are available for various sized tubing. These fittings thread directly into feeder valve or outlet check valve ports and securely hold the tubing. Part number for ordering depends on tubing size, type of feeder or outlet check valve, and whether the fitting is installed on the inlet or outlet of the feeder valve.

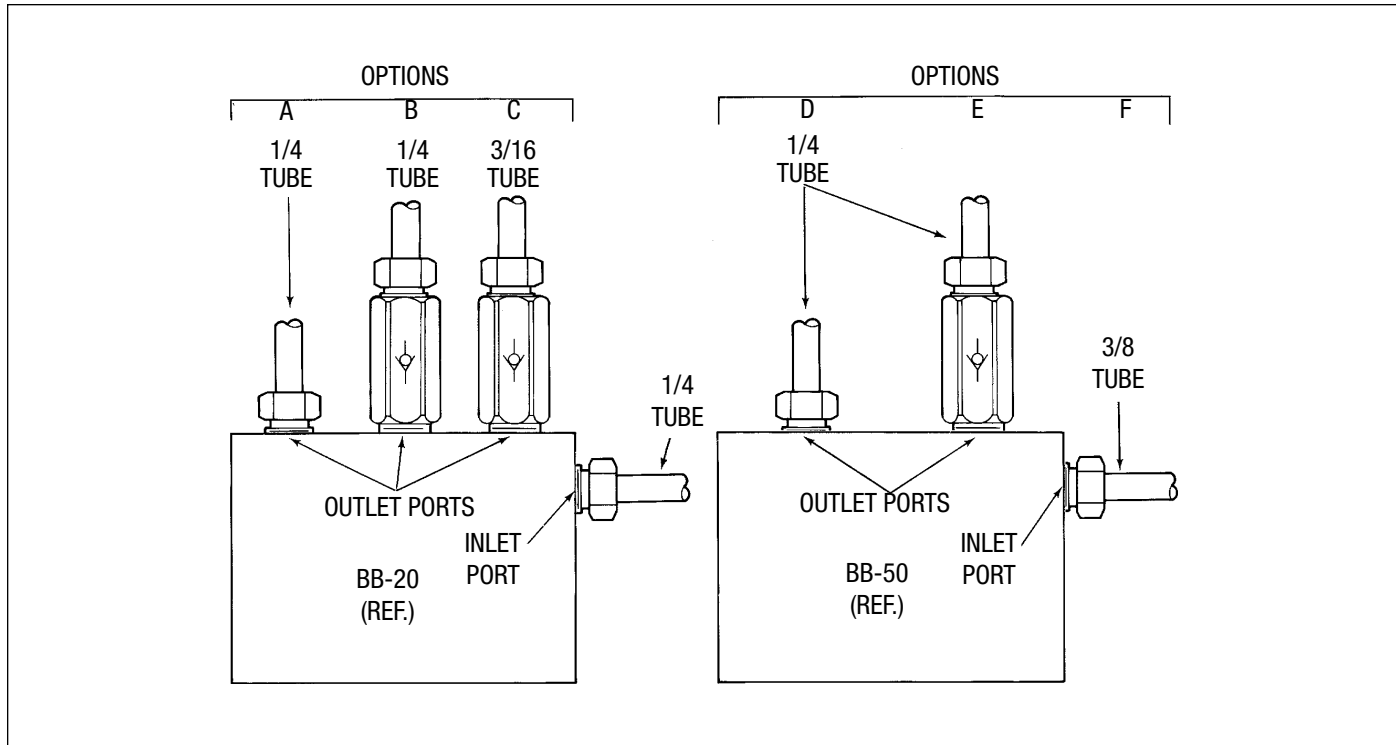

Figure 18. Special Tube Fitting

**Ordering Outlet Check Valves and Special Tube Fittings.**

Figure 19 represents the various options of outlet check valves and special tube fittings on BB-20 and BB-50 series feeder valves. If special tube fittings are not desired, just the outlet check valve

may be ordered. Outlet ports on outlet check valves used on BB-20 series feeder valves are 1/8-27 NPSF. Outlet ports on outlet check valves for BB-50 series feeder valves are 1/4-18 NPSF.



**Figure 19. Outlet Check Valve and Special Tube Fitting Options**

ORDERING INFORMATION		
Description	Part No.	Old Part No.
<b>BB-22</b>		
<b>A</b> Special Tube Fitting	561227	515-321-000
<b>B</b> Special Tube Fitting	-	515-312-000
Outlet Check Valve	564017	463-001-546
<b>C</b> Special Tube Fitting	-	515-321-100
Outlet Check Valve	-	463-001-548

ORDERING INFORMATION		
Description	Part No.	Old Part No.
<b>BB-50</b>		
<b>D</b> Special Tube Fitting	561228	515-322-000
<b>E</b> Special Tube Fitting	561228	515-322-000
Outlet Check Valve	564018	463-001-550
<b>F</b> Special Tube Fitting	-	515-323-000

REFER TO FOLLOWING FOR ADDITIONAL PUMP INFORMATION	
<b>Bulletin L12415</b>	Manual Pumps (PH w/two outlet valve)
<b>Bulletin L12000</b>	Pneumatic and Hydraulic Pumps (Modu-Flo)
<b>Bulletin L12200</b>	Air Barrel Pumps (40:1 & 50:1 ratio)

All written and visual data contained in this document are based on the latest product information available at the time of publication. Graco reserves the right to make changes at any time without notice.

**Contact us today!**

To receive product information or talk with a Graco representative, call 800-533-9655 or visit us online at [www.graco.com](http://www.graco.com).

