

# EO-1 Pump Packages

## DESCRIPTION

EO-1 is a versatile series of pumping units designed for use with virtually any type of intermittent lube system requiring oil flow up to 12 in<sup>3</sup>/min (200 cc/min). Each of these lube packages consists of a 115 or 230 volt AC, 50/60 Hz, single phase electric motor direct coupled to a gear pump and mounted on a steel or plastic reservoir. A wide range of reservoir sizes are available and all are equipped with a low level switch as standard. These pump assemblies are rated for service up to 580 psi (40 bar). See "Specifications" for additional details.

## FEATURES

- Built in vent valve permits use with single line parallel systems.
- And adjustable internal relief protects pump from excessive pressures. Factory set at 580 psi (40 bar).
- Reservoir with removable covers, sized at 0.8, 1.6, 2.0 and 3.2 gallons (3, 6 and 12 liters).
- Reservoir has a visual level gauge, pressure gauge and filler/strainer with screw on cap.
- Motor and low level switch meet EEC requirements (CE Mark compliance).



## OPERATION

The motor/pump assembly on an EO-1 pump package runs whenever power is applied. On/off cycles are achieved by using an optional timer that has user selectable off and on times or control can be via the machine PLC where available and desired.

## APPLICATIONS

The EO-1 is ideal for small to medium size series progressive of parallel systems requiring intermittent metered lubrication with an electrically driven pump. Combined with Trabon series progressive divider valves, LubriSystem Injectors, or Injecto-Flo Piston Distributors, the EO-1 can be operated on a timer, cycle switch, or pressure switch controlled cycle for precision lubrication.

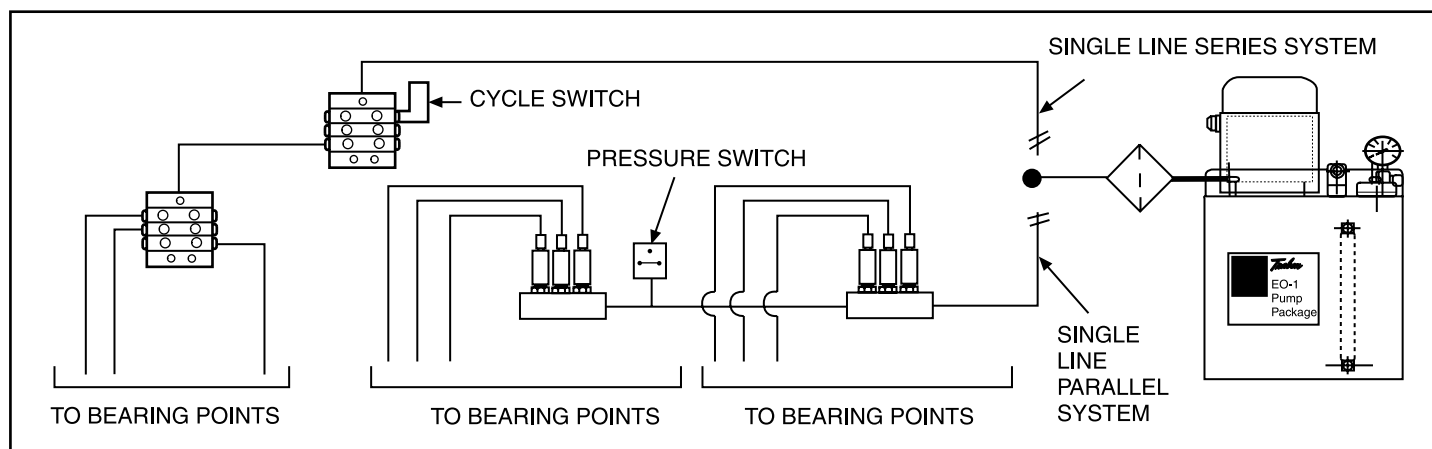

Figure 1

SPECIFICATION	
<b>Motor Voltage</b>	115 ± 10% VAC, 50/60 Hz, 1Ø 230 ± 10% VAC, 50/60 Hz, 1Ø
<b>Current Consumption</b>	4.3A in-rush, 2.15A running @ 110 VAC, 1Ø 1.9A in-rush, 0.9A running @ 220 VAC, 1Ø
<b>Motor Power</b>	1/12 HP
<b>Motor Speed</b>	1680 RPM @ 60 Hz, 1Ø 1340 RPM @ 50 Hz, 1Ø
<b>Pump Flow Rate</b>	12 in <sup>3</sup> /min (200 cc/min), see chart below
<b>Pressure</b>	Relief valve protected 145-650 psi (10-45 bar) Factory set @ 580 psi (40 bar)
<b>Oil Viscosity</b>	ISO 50-1500 (SUS 250-5000)
<b>Operation</b>	Intermittent, 20% Duty Cycle @ max pressure (650 psi)

<b>Low Level Switch</b>	10 watt @ 110/220 VAC, 50/60 Hz, 1 pH Contacts (normal closed, held open)
<b>Suction Strainer</b>	100 mesh screen
<b>Pressure Gauge</b>	0-850 psi (0-60 bar)
<b>Electrical Connections</b>	Wire terminals in motor junction box, screw terminals in Low Level Switch connector
<b>Reservoir Material</b>	
<b>Translucent Plastic</b>	1 gallon polypropylene 2 gallon glass filled nylon 6-6
<b>Metal</b>	Painted steel with guarded glass level tube

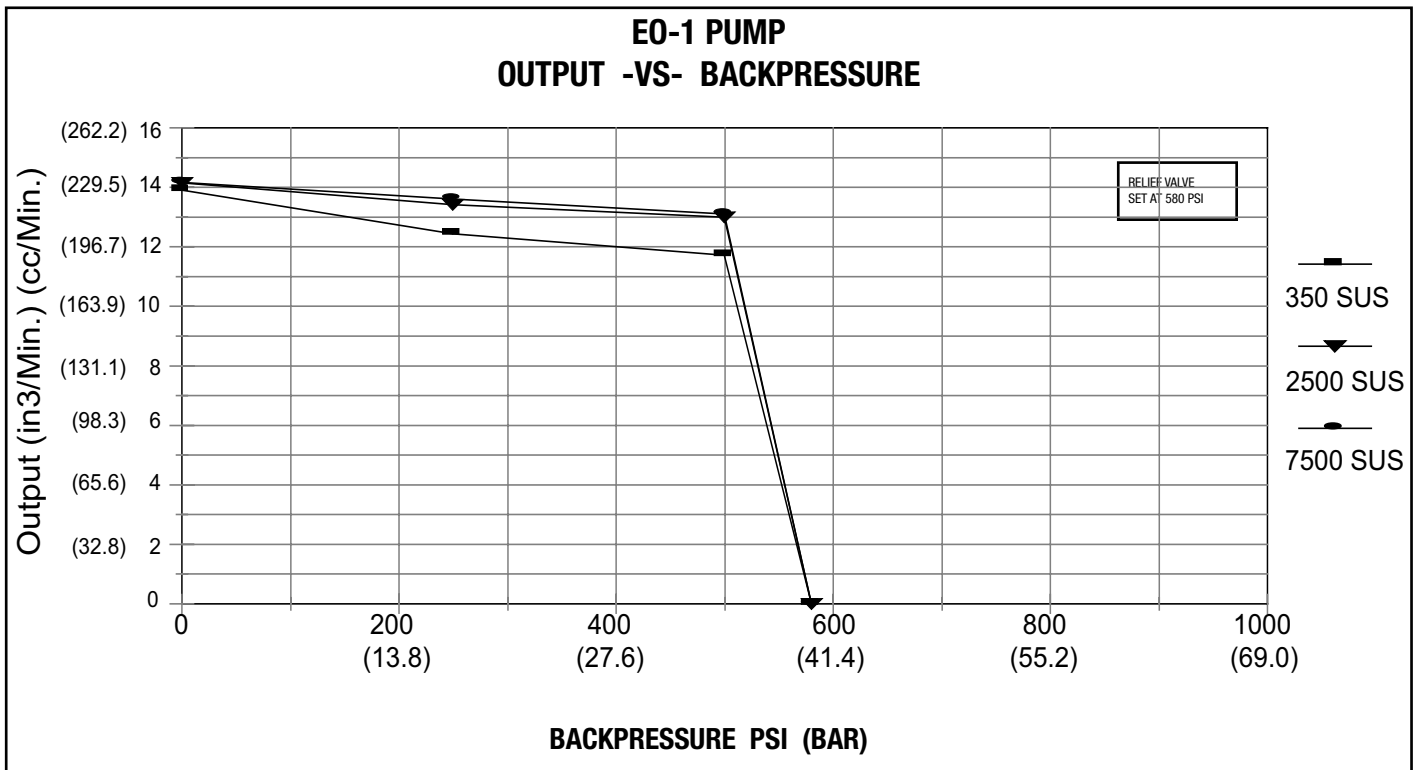

Figure 2

Test oils = Mobile DTE Light - 158 SUS @ 100°F (350 SUS @ 70°F), Mobilgear 629 - 750 SUS @ 100°F (2500 SUS @ 70°F), Mobilgear 634 - 2337 SUS @ 100°F (7500 SUS @ 70°F)

**INSTALLATION DATA**

**Mounting**

The entire lube package is installed with two 1/4" screws that pass through holes in the mounting flange at the top of the reservoir. Mounting dimensions are given in Figure 3 and Table 1.

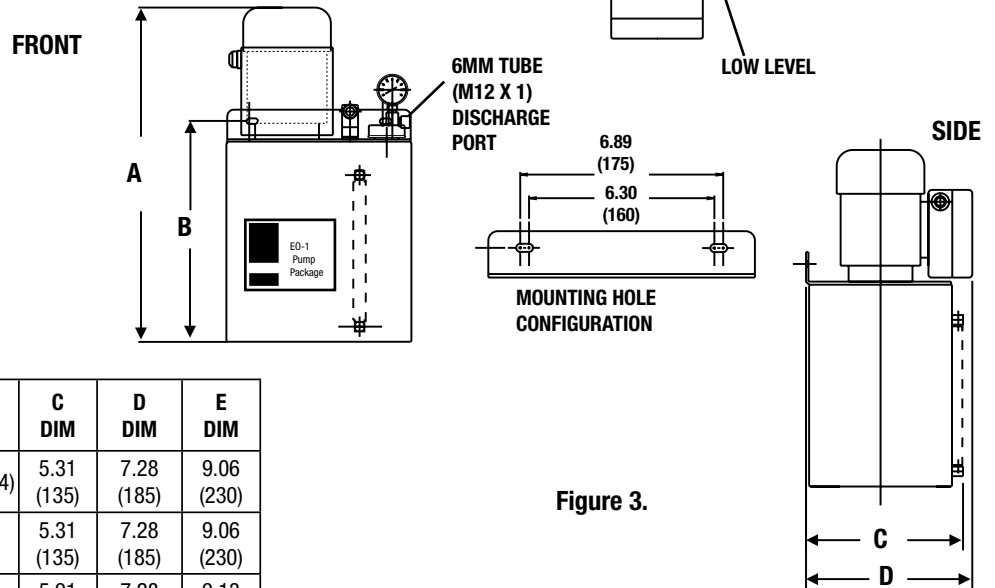

Table 1

RESERVOIR SIZE	A DIM	B DIM	C DIM	D DIM	E DIM
.8 Gal. (3L) Plastic	12.76 (324)	7.25 (184)	5.31 (135)	7.28 (185)	9.06 (230)
1.6 Gal. (6L) Plastic	16.50 (419)	11.00 (279)	5.31 (135)	7.28 (185)	9.06 (230)
1.6 Gal. (6L) Metal	16.44 (418)	10.94 (278)	5.91 (150)	7.28 (185)	9.13 (232)
3.2 Gal. (12L) Metal	16.44 (418)	10.94 (278)	7.76 (197)	8.21 (209)	9.13 (232)

Figure 3.

**Electrical Hookup**

Figure 4 is a simplified schematic for the entire pumping unit. The electrical hookups are shown in Figures 5a, 5b and 5c. Wiring to the motor and switch should be with 16 AWG stranded wire and insulation rated for 115/230 VAC and 105°C.

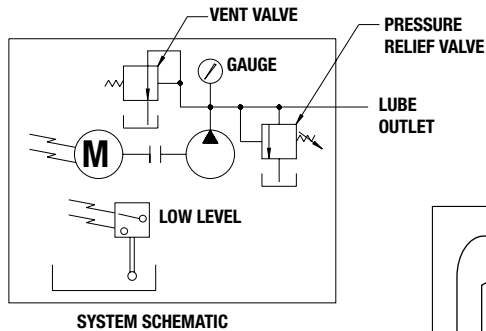

Figure 4.

Figure 5a  
CANTONI & ABB MOTORS

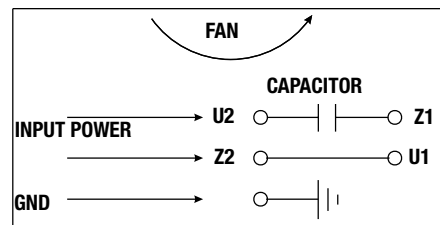

Figure 5b  
MOTO TECHNICA 1 PH MOTORS

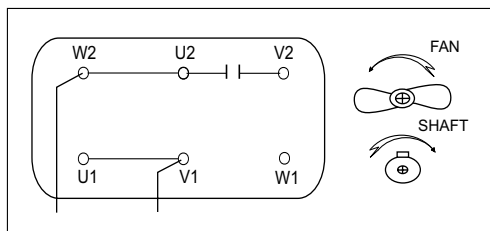
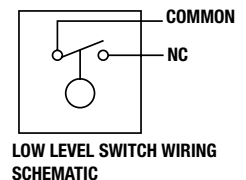

Figure 5c



<b>ORDERING INFORMATION</b>		
<b>Description</b>	<b>Part No.</b>	<b>Old Part No.</b>
0.8 gallon (3 liter) Plastic Reservoir, 110V	562837	126-400-010
0.8 gallon (3 liter) Plastic Reservoir, 220V	24B427	126-400-020
1.6 gallon (6 liter) Plastic Reservoir, 110V	562839	126-400-030
1.6 gallon (6 liter) Plastic Reservoir, 220V	562840	126-400-040
1.6 gallon (6 liter) Metal Reservoir, 110V	562843	126-400-050
1.6 gallon (6 liter) Metal Reservoir, 220V	–	126-400-060
3.2 gallon (12 liter) Metal Reservoir, 110V	562844	126-400-070
3.2 gallon (12 liter) Metal Reservoir, 220V	24B429	126-400-080

NOTE: Motor voltages are 50/60 Hz and single phase.

<b>SPARE PARTS ORDERING INFORMATION</b>		
<b>Description</b>	<b>Part No.</b>	<b>Old Part No.</b>
Adjustable Relief Valve	556015	126-410-007
Gear Pump Only	556013	126-410-005
Low Level Switch Assembly, 0.8 gallon	122117	126-410-013
Low Level Switch Assembly, 1.6/3.2 gallon	556016	126-410-009
Suction Strainer	556014	126-410-006
Motor		
110 VAC	556011	126-410-000
220 VAC	556012	126-410-001
Pressure Gauge, 0-850 psi (0-60 bar)	–	126-410-011
Adapter, M12 x 1(M) x 1/4 NPTF (FM)	–	435-702-471

## MAINTENANCE INFORMATION

Normally, the only maintenance required on EO-1 packages is filling the reservoir, and cleaning the suction strainer. Use only fresh, uncontaminated oil (ISO 18/14 cleanliness level) to fill the reservoir. Check the suction strainer annually, or more often if the pump is becoming noisy (cavitating) between cleaning. The suction strainer is accessed by removing the reservoir cover. It is also a good idea to periodically verify pump operation (lube delivery), the calibration of the timer settings and the actuation depth of the low level switch.

Graco endorses the SAE recommendation of ISO 18/14 (ISO 4406) oil cleanliness for most bearing applications. Some high speed bearings may require cleaner oil. Consult the bearing manufacturer for recommendation.

All written and visual data contained in this document are based on the latest product information available at the time of publication. Graco reserves the right to make changes at any time without notice.

## Contact us today!

To receive product information or talk with a Graco representative, call 800-533-9655 or visit us online at [www.graco.com](http://www.graco.com).

