

MSA-100 Air Operated Pump

DESCRIPTION

The MSA-100 is an air-operated pump with an adjustable volume output. It is designed to be used in series progressive oil or grease lubrication systems.

Lubricant can be supplied to the MSA-100 pump by either a gravity feed reservoir or a pressurized source such as a bulk header that exerts up to 500 psi at the pump inlet. This pressure handling capability results from the valve action of the MSA-100. Its piston prevents lubricant from flowing into the lube system when the piston is in the priming position.

The MSA-100 is supplied as a single-acting pump. However, it can be easily field-converted to double-acting by simply removing the air breather from the double-acting port and installing an air line.

FEATURES

- Adjustable lube output, from .400 to .800 cubic inches per stroke, permits a broad range of applications.
- The MSA-100 is ideal for bulk header lube systems because it can handle up to 500 psi inlet pressure.
- Single-or double-acting air cylinder provides wide choice of controls.
- Ability to pump either oil or grease expands the opportunity to standardize on the MSA-100 through out the plant or shop.
- High pressure relief protection reduces chance of damage to the lube system in case of blockage.
- Can be piped to standard Trabon reservoirs (Refer to bulletin L12000 for reservoirs).

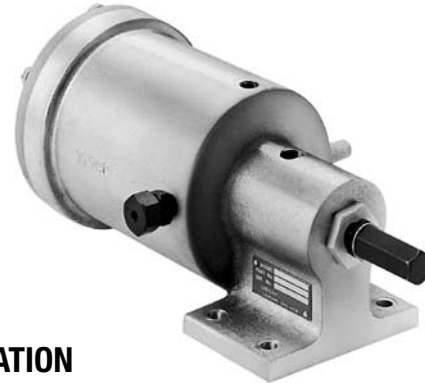
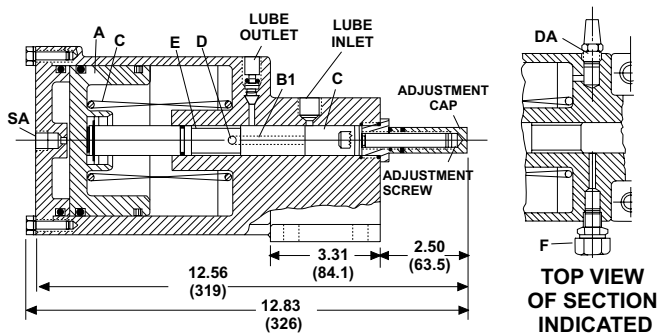

OPERATION

When air is supplied in the single-acting port (SA), the pump piston (A) is moved forward. The lube inlet is closed by the piston (B1). The lubricant in the chamber (C) is forced into a channel in the middle of the piston (B1). An outlet hole (D) from that channel opens into an undercut (E) on the piston. When the undercut opens to the lube outlet, the lubricant flows, under pressure, to the lube system. If a blockage occurs in the lube system, the rupture to atmosphere indicator (F) ruptures and the pressure is relieved. When the air has been vented from the single-acting inlet, the piston return spring (G) returns the piston to its original position, reopening the lube inlet and allowing new lubricant to enter chamber (C) for the next cycle.

If the pump is double-acting, air will be supplied in the double-acting air inlet (DA) as air is vented from the single-acting port to return the piston to its original position.

SPECIFICATIONS	
Material	Aluminum
Seals	Buna-N and Viton
Output per Stroke	.400-.800 cu.in (6.566-13.112 cm ³)
Max Pump Stokes per Min	
Single-Acting	15
Double-Acting	30
Operating Pressure	
Air Inlet	60-140 psi (4-10 bar)
*Max Lube Inlet	500 psi (35 bar)
Max Lube Outlet	3000 psi (207 bar), supplied with 1450 psi Rupture-To-Atmosphere Indicator
Lubricant	Oil or Grease
Air to Lube	25:1

*When connected to pressurized supply, back-flow to supply must be permitted; alternatively, a small accumulator or 3 ft of 1/2 in ID hose can be connected to lube inlet of pump.

DIMENSIONS Inches (mm)

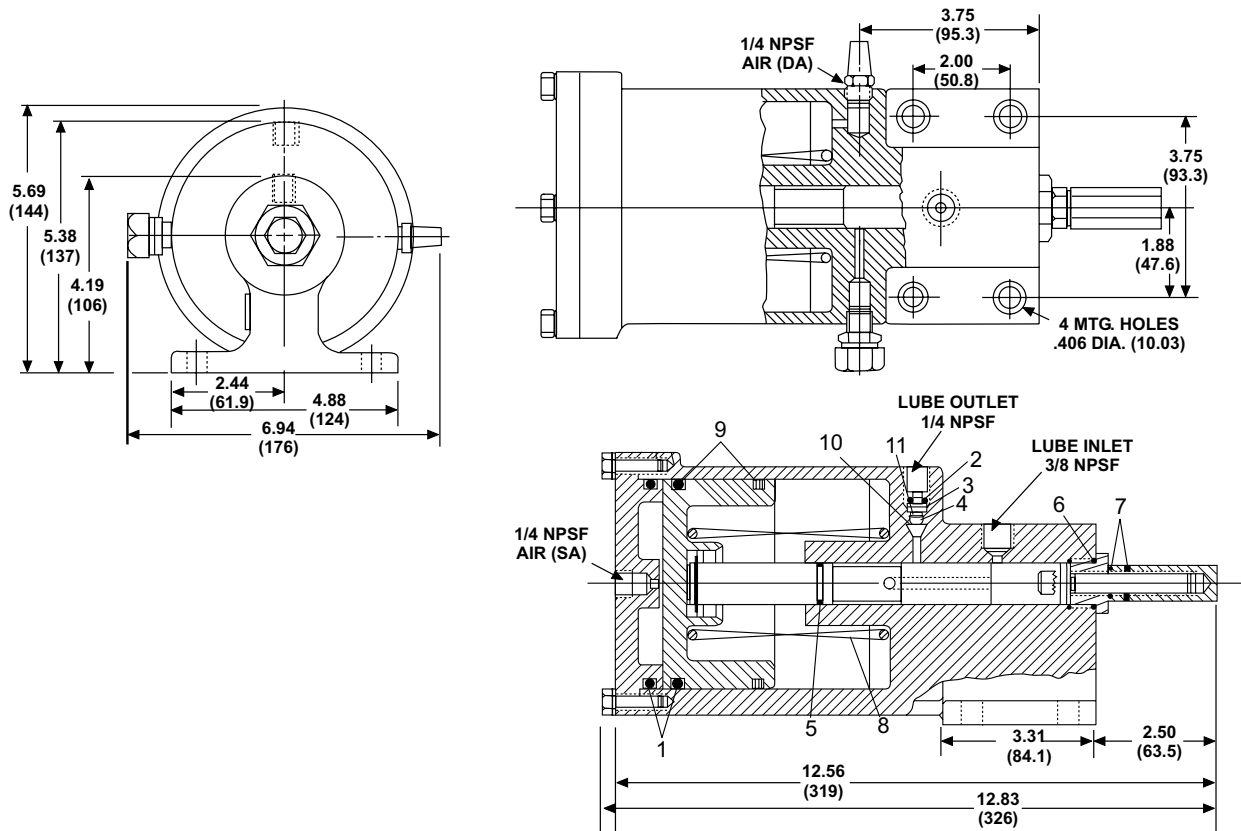

INSTALLATION INSTRUCTIONS

1. Mount pump, using all four mounting holes.
2. If you intend the MSA-100 to operate as a double-acting pump, remove the vent plug from the double-acting inlet port and install the air line to that inlet.
3. Seal all pipe connections. **DO NOT USE PTFE TYPE TAPE.**
4. Cycle the pump until all air is removed and lubricant runs clear at the outlet.
5. To adjust pump output, remove adjustment screw cap and turn the screw clockwise to reduce output, or counter clockwise to increase output.

ORDERING INSTRUCTIONS

Description	Part No.	Old Part No.
MSA-100 Pump	562855	140-000-171
1450 psi Rupture-To-Atmosphere Indicator	—	511-839-100
*Repair Parts Kit: four O-Rings (1,5 & 6), Keeper (2), Check Valve Spring (3), 3/8 in Viton Ball (4), two Gaskets (7), Return Spring (8), two Spiral Back-Up Rings (9), Poppet (10), Spring Rest (11), Instructions for Installation	563913	560-001-560
Air Inlet Restrictor (not shown)	563072	463-410-080

For higher pressure rupture discs, refer to Bulletin L15401 or contact your Trabon Distributor.

*(#) represent numbers marked out in diagram above.

All written and visual data contained in this document are based on the latest product information available at the time of publication. Graco reserves the right to make changes at any time without notice.

Contact us today!

To receive product information or talk with a Graco representative, call 800-533-9655 or visit us online at www.graco.com.

