

# Dyna-Star<sup>®</sup> HP and HF Pump

332514P  
EN

---

**Provides lubricant flow and pressure to operate a single line automatic lubrication system. For automatic lubrication systems only. For professional use only. Not approved for use in explosive atmospheres or hazardous locations.**



Important Safety Instructions  
Read all warnings and instructions in this manual. Save these instructions.

**Models: Page 2; Series C**

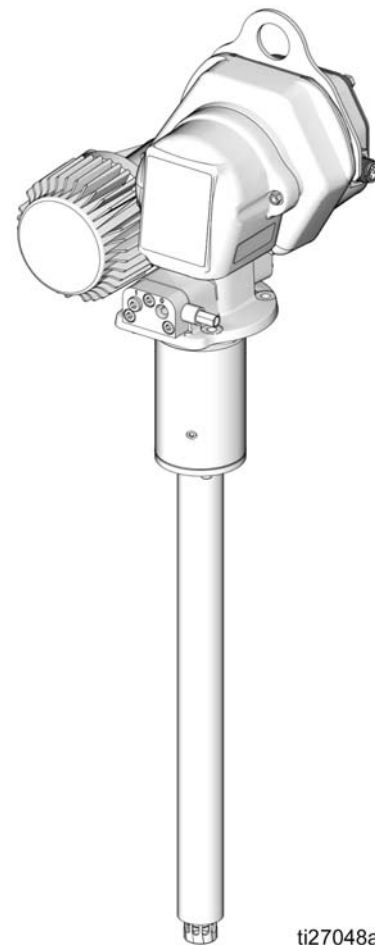

ti27048a







# Models







| Pump Models | Tube in Tube | HP Pump | HF Pump | Vent Valve | Compatible Reservoirs |              |           | Maximum Working Pressure      |                                |
|-------------|--------------|---------|---------|------------|-----------------------|--------------|-----------|-------------------------------|--------------------------------|
|             |              |         |         |            | 35/60 Pound           | 90/120 Pound | 400 Pound | 3500 psi<br>24.1 MPa, 241 bar | 5000 psi<br>34.47 MPa, 344 bar |
| 77X000      |              | X       |         |            | X                     |              |           |                               | X                              |
| 77X001      | X            | X       |         |            | X                     |              |           |                               | X                              |
| 77X002      | X            | X       |         |            |                       | X            |           |                               | X                              |
| 77X003      | X            | X       |         |            |                       |              | X         |                               | X                              |
| 77X011      | X            | X       |         | X          | X                     |              |           | X                             |                                |
| 77X012      | X            | X       |         | X          |                       | X            |           | X                             |                                |
| 77X013      | X            | X       |         | X          |                       |              | X         | X                             |                                |
| 77X014      |              |         | X       |            | X                     |              |           | X                             |                                |
| 77X015      |              |         | X       |            |                       | X            |           | X                             |                                |
| 77X016      |              |         | X       |            |                       |              | X         | X                             |                                |

# Warnings

The following warnings are for the setup, use, grounding, maintenance, and repair of this equipment. The exclamation point symbol alerts you to a general warning and the hazard symbols refer to procedure-specific risks. When these symbols appear in the body of this manual or on warning labels, refer back to these Warnings. Product-specific hazard symbols and warnings not covered in this section may appear throughout the body of this manual where applicable.

|  <b>WARNING</b>  |   |
|---|---|
|    | <p><b>FIRE AND EXPLOSION HAZARD</b></p> <p>When flammable fluids are present in the work area, such as gasoline and windshield wiper fluid, be aware that flammable fumes can ignite or explode. To help prevent fire and explosion:</p> <ul style="list-style-type: none"> <li>• Use equipment only in well ventilated area.</li> <li>• Eliminate all ignition sources, such as cigarettes and portable electric lamps.</li> <li>• Keep work area free of debris, including rags and spilled or open containers of solvent and gasoline.</li> <li>• Do not plug or unplug power cords or turn lights on or off when flammable fumes are present.</li> <li>• Ground all equipment in the work area.</li> <li>• Use only grounded hoses.</li> <li>• <b>Stop operation immediately</b> if static sparking occurs or you feel a shock. Do not use equipment until you identify and correct the problem.</li> <li>• Keep a working fire extinguisher in the work area.</li> </ul> |
| <br><br> | <p><b>SKIN INJECTION HAZARD</b></p> <p>High-pressure fluid from dispensing device, hose leaks, or ruptured components will pierce skin. This may look like just a cut, but it is a serious injury that can result in amputation. <b>Get immediate surgical treatment.</b></p> <ul style="list-style-type: none"> <li>• Do not point dispensing device at anyone or at any part of the body.</li> <li>• Do not put your hand over the fluid outlet.</li> <li>• Do not stop or deflect leaks with your hand, body, glove, or rag.</li> <li>• Follow the <b>Pressure Relief Procedure</b> when you stop dispensing and before cleaning, checking, or servicing equipment.</li> <li>• Tighten all fluid connections before operating the equipment.</li> <li>• Check hoses and couplings daily. Replace worn or damaged parts immediately.</li> </ul>   |

# ! WARNING

|   |  |
|---|--|
|       | <p><b>PRESSURIZED EQUIPMENT HAZARD</b></p> <p>Over-pressurization can result in equipment rupture and serious injury.</p> <ul style="list-style-type: none"> <li>• A pressure relief valve is required at each pump outlet.</li> <li>• Follow <b>Pressure Relief Procedure</b> in this manual before servicing.</li> </ul>   |
|    | <p><b>PRESSURIZED ALUMINUM PARTS HAZARD</b></p> <p>Use of fluids that are incompatible with aluminum in pressurized equipment can cause serious chemical reaction and equipment rupture. Failure to follow this warning can result in death, serious injury, or property damage.</p> <ul style="list-style-type: none"> <li>• Do not use 1,1,1-trichloroethane, methylene chloride, other halogenated hydrocarbon solvents or fluids containing such solvents.</li> <li>• Many other fluids may contain chemicals that can react with aluminum. Contact your material supplier for compatibility.</li> </ul>   |
|       | <p><b>EQUIPMENT MISUSE HAZARD</b></p> <p>Misuse can cause death or serious injury.</p> <ul style="list-style-type: none"> <li>• Do not operate the unit when fatigued or under the influence of drugs or alcohol.</li> <li>• Do not exceed the maximum working pressure or temperature rating of the lowest rated system component. See <b>Technical Data</b> in all equipment manuals.</li> <li>• Use fluids and solvents that are compatible with equipment wetted parts. See Technical Data in all equipment manuals. Read fluid and solvent manufacturer's warnings. For complete information about your material, request MSDS from distributor or retailer.</li> <li>• Turn off all equipment and follow the <b>Pressure Relief Procedure</b> when equipment is not in use.</li> <li>• Check equipment daily. Repair or replace worn or damaged parts immediately with genuine manufacturer's replacement parts only.</li> <li>• Do not alter or modify equipment. Alterations or modifications may void agency approvals and create safety hazards.</li> <li>• Make sure all equipment is rated and approved for the environment in which you are using it.</li> <li>• Use equipment only for its intended purpose. Call your distributor for information.</li> <li>• Route hoses and cables away from traffic areas, sharp edges, moving parts, and hot surfaces.</li> <li>• Do not kink or over bend hoses or use hoses to pull equipment.</li> <li>• Keep children and animals away from work area.</li> <li>• Comply with all applicable safety regulations.</li> </ul> |
|   | <p><b>MOVING PARTS HAZARD</b></p> <p>Moving parts can pinch, cut or amputate fingers and other body parts.</p> <ul style="list-style-type: none"> <li>• Keep clear of moving parts.</li> <li>• Do not operate equipment with protective guards or covers removed.</li> <li>• Pressurized equipment can start without warning. Before checking, moving, or servicing equipment, follow the <b>Pressure Relief Procedure</b> and disconnect all power sources.</li> </ul>  |

 **WARNING****BURN HAZARD**

Equipment surfaces and fluid that's heated can become very hot during operation. To avoid severe burns:

- Do not touch hot fluid or equipment.

**PERSONAL PROTECTIVE EQUIPMENT**

Wear appropriate protective equipment when in the work area to help prevent serious injury, including eye injury, hearing loss, inhalation of toxic fumes, and burns. This protective equipment includes but is not limited to:

- Protective eyewear, and hearing protection.
- Respirators, protective clothing, and gloves as recommended by the fluid and solvent manufacturers.

# Typical Installation: Injector System

The installation shown in below is only a guide for selecting and installing system components. Contact your Graco distributor for assistance in planning a system to suit your needs.

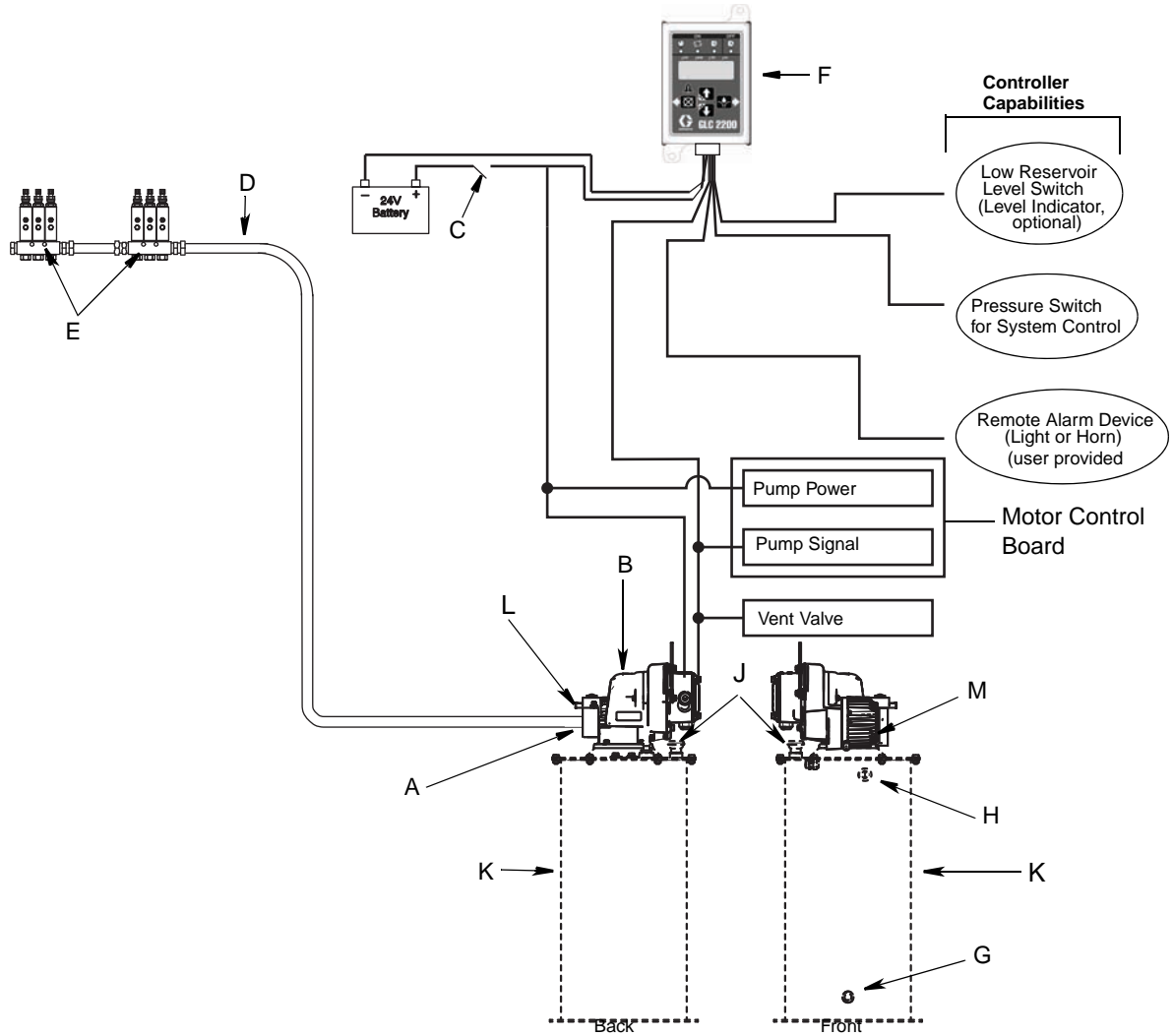

FIG. 1

**Key:**

- |  |                                   |
|--|-----------------------------------|
| A Lubricant output connection                                  | K Reservoir / Tank                |
| B Pump   | L Vent Valve (for reference only) |
| C Ignition switch*   | M Motor                           |
| D High-pressure lubricant supply lines*                        |                                   |
| E Injector banks*  |                                   |
| F Lubrication controller*                                      |                                   |
| G Fill port (for reference only; non-tube-in-tube models only) |                                   |
| H Overflow port (for reference only)                           |                                   |
| J Breather (for reference only)                                |                                   |

\*User provided

# Typical Installation: Series Progressive System

The installation shown below is only a guide for selecting and installing system components. Contact your Graco distributor for assistance in planning a system to suit your needs.

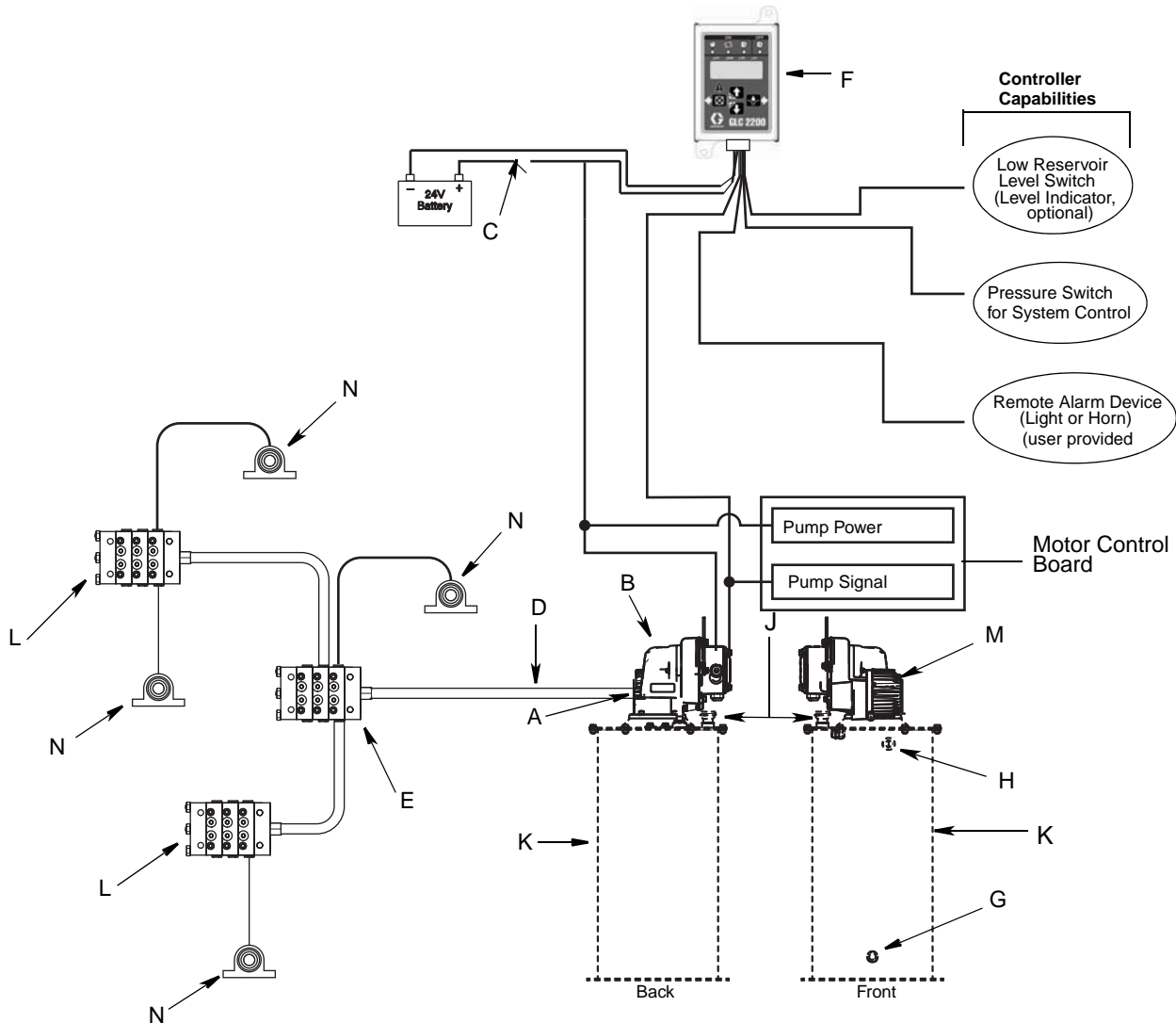

FIG. 2

**Key:**

- |  |                             |
|--|-----------------------------|
| A Lubricant output connection                                  | L Secondary metering device |
| B Pump   | M Motor                     |
| C Ignition switch*   | N Bearing                   |
| D High-pressure lubricant supply lines*                        |                             |
| E Primary metering device*                                     |                             |
| F Lubrication controller*                                      |                             |
| G Fill port (for reference only; non-tube-in-tube models only) |                             |
| H Overflow port (for reference only)                           |                             |
| J Breather (for reference only)                                |                             |
| K Reservoir / Tank (for reference only)                        |                             |

\*User provided

# Installation

## Pressure Relief



Follow the Pressure Relief Procedure whenever you see this symbol.



This equipment stays pressurized until pressure is manually relieved. To help prevent serious injury from pressurized fluid, such as skin injection, splashing fluid and moving parts, follow the Pressure Relief Procedure when you stop dispensing and before cleaning, checking, or servicing the equipment.

To relieve pressure in the system, use two wrenches working in opposite directions on the pump outlet fitting to **slowly loosen the fitting only** until the fitting is loose and no more lubricant or air is leaking from fitting (see FIG. 3).

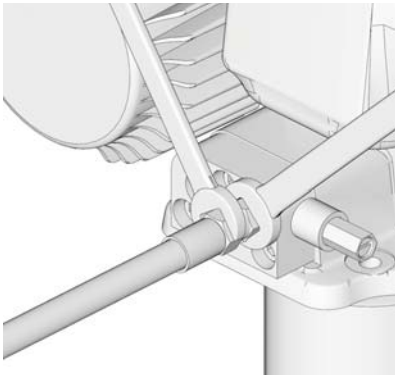

FIG. 3

## Pump Module

Reference numbers used in the following instructions refer to Parts, page 35. Upper case reference letters used in the following instructions refer to Typical Installation Drawings provided on pages 6 and 7.

### NOTE:

- Tank / reservoir covers and reservoirs are available from Graco. Contact your Graco Distributor or Graco Customer Service for assistance ordering these parts. See Parts, page 38 for a complete list of accessories.
- Before installing pump on tank / reservoir, use bolts to secure tank / reservoir to it's installation location.

- Install tank / reservoir cover on tank / reservoir. Tighten screws to secure cover to tank / reservoir.
1. Remove pump mounting screws (a) and washers (b) from tank / reservoir cover. Save these parts. Gasket (c) should not be removed from the cover. These parts will be used to install the pump to the tank / reservoir cover for reassembly.

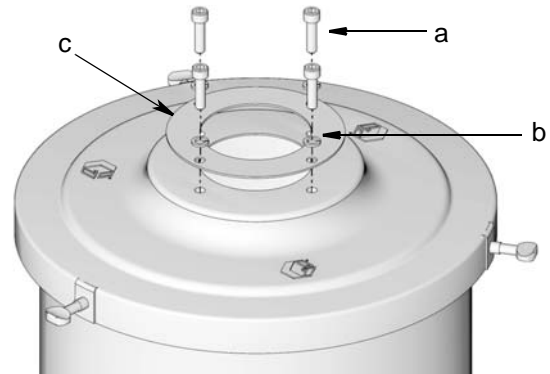

FIG. 4: 120 Pound Cover Shown

2. Loosen bolts (128) and remove cover (126) from Dyna-Star pump (FIG. 5).

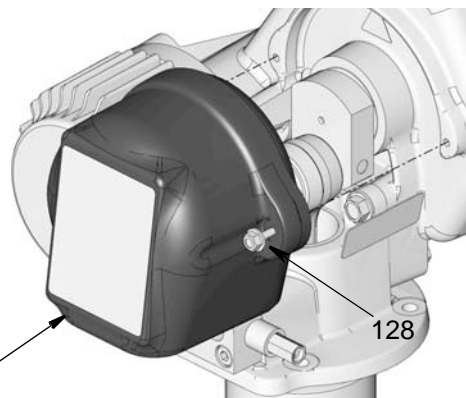

FIG. 5



- Remove protective cap (d) from pump down-tube (208) (FIG. 6). Discard cap. You will not use it again.

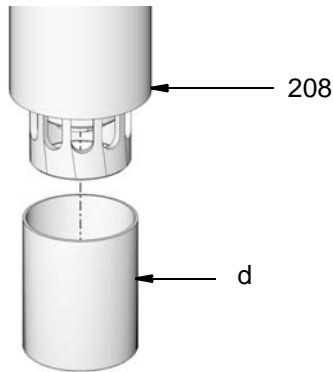

FIG. 6

- Verify gasket (c) is in place on top the reservoir cover, laying flat and that the holes (e) in the gasket align with the holes in the cover (FIG. 7).

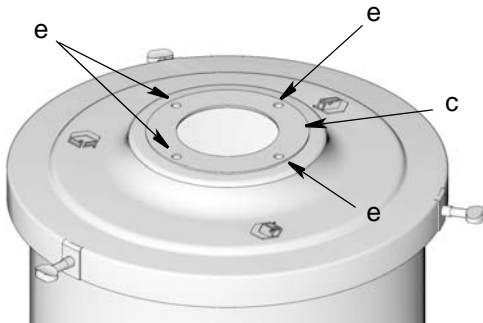

FIG. 7



**HEAVY EQUIPMENT HAZARD**

Lifting or moving heavy equipment incorrectly can cause serious injury. To avoid serious injuries, such as muscle strain or back injuries, when moving pump always use a lifting aid secured to the pump lift ring . See Technical Data, included in the pump instruction manual for pump weight information.

- Install pump down-tube through opening in the center of the gasket and tank / reservoir cover and into tank / reservoir.
- Align holes in pump base with holes in tank / reservoir cover (FIG. 8). Securely fasten pump to tank / reservoir cover using screws (a) and washers (b) removed in Step 1, page 8.

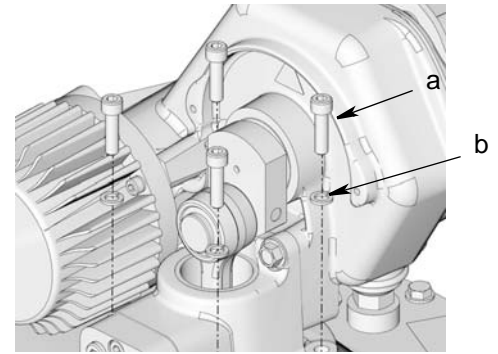

FIG. 8

**NOTE:** When the pump is correctly installed on the Graco tank, the breather (J) will be below the control box (115) as shown in FIG. 9.

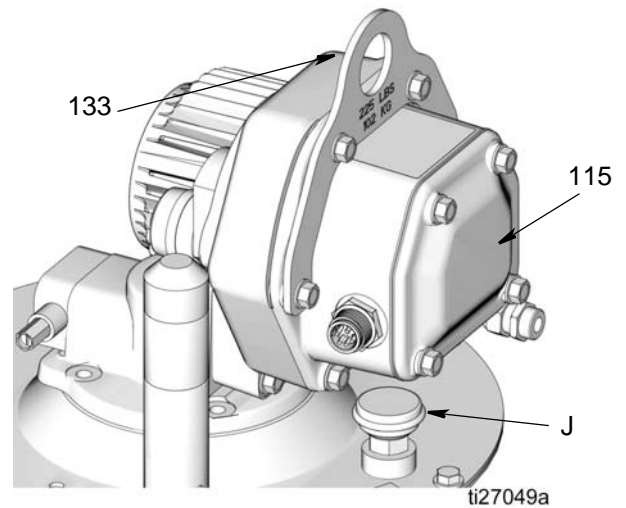

FIG. 9

**NOTICE**

To prevent damage to the unit:

- Check breather (J) vent for proper operation before filling reservoir.
- Open overflow port (H) before filling reservoir to visually inspect lubrication level.
- Do not fill reservoir beyond overflow port (H).
- Do not use breather vent as a port to fill reservoir.

7. Reinstall cover (126) using bolts (128). Use a wrench to tighten bolts securely (FIG. 10).

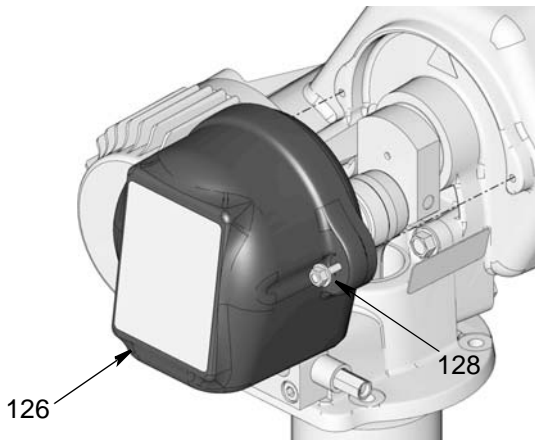

**FIG. 10**

8. Connect the timer/controller (F) (user supplied, if used).
9. Connect High Pressure Lubricant Supply Line (D) to the Lubricant Output Connection (O) (FIG. 11) on the Vent Valve or Manifold.

**NOTE:** The High Pressure Lubricant Supply Line (D) is disconnected from the Lubricant Output Connection (O) during Priming, page 15.

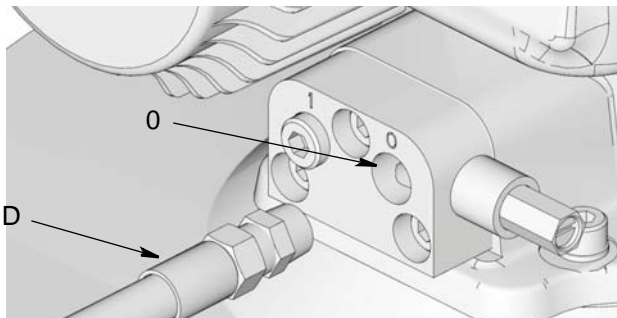

**FIG. 11: Lubricant Outlet Connection**

## Wiring Grounding

### Fuses

|   |   |   |  |  |  |  |
|---|---|---|--|--|--|--|
| ⚠   | ⚡ | ⏚ |  |  |  |  |
| <p>The equipment must be bonded (grounded) directly to the truck. Grounding reduces the risk of static shock due to static build up on the equipment.</p> |   |   |  |  |  |  |

| <b>NOTICE</b>   |  |
|---|--|
| <p>Fuses (user supplied) are required on all models. To avoid equipment damage:</p> <ul style="list-style-type: none"> <li>Never operate the Dyna-Star Pump models without a fuse installed.</li> <li>A fuse of the correct voltage and amperage must be installed in line with the power entry to the system. Graco recommends using 35A fuses.</li> </ul> |  |

## System Configuration and Wiring

**NOTE:** The pump is equipped with a 6-pin (4 pins are used), M23 connector (31) for use with Graco cable wiring harness kits 77X545 and 77X546. See Parts page 38.

FIG. 12 shows the pump connections when used with Graco Wire Harness 77X545 or 77X546. Also see pages 12 and 13 for connection details when a customer/user supplied wiring harness is used.

**NOTICE**

To avoid equipment damage, remove power before switching modes from signal to power or power to signal.

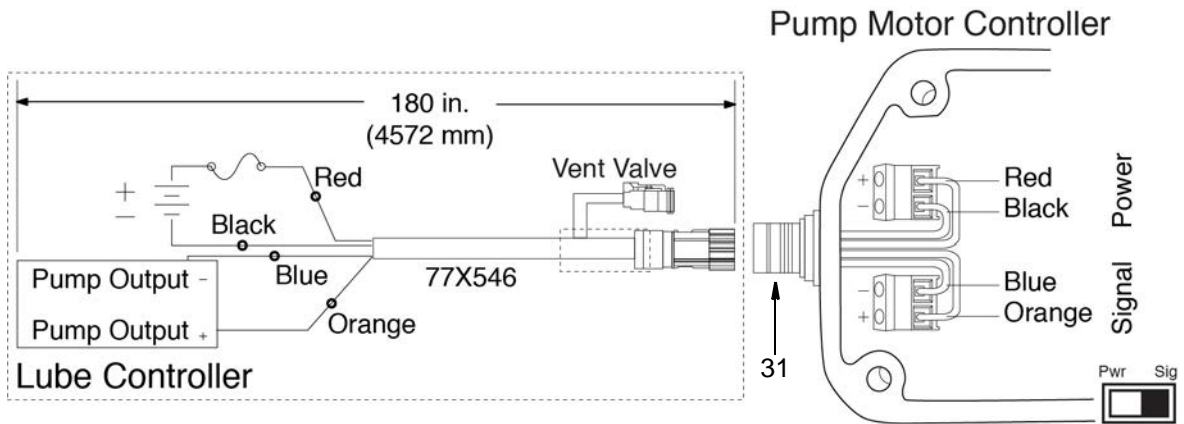

ti25987

**FIG. 12**

### Wire Connection Table

| Pin | Wire Color | Connection |
|-----|------------|------------|
| 1   | Orange     | Signal +   |
| 2   | Black      | Power -    |
| 4   | Red        | Power +    |
| 5   | Blue       | Signal -   |

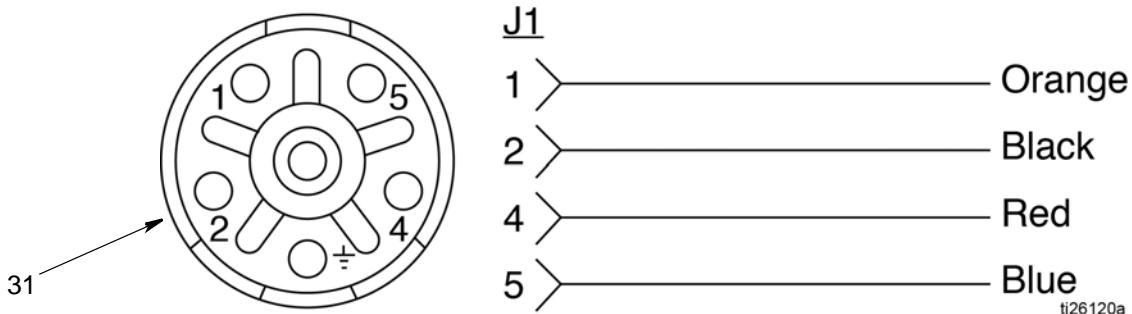

ti26120a

**FIG. 13**

### 24 VDC With Signal Input

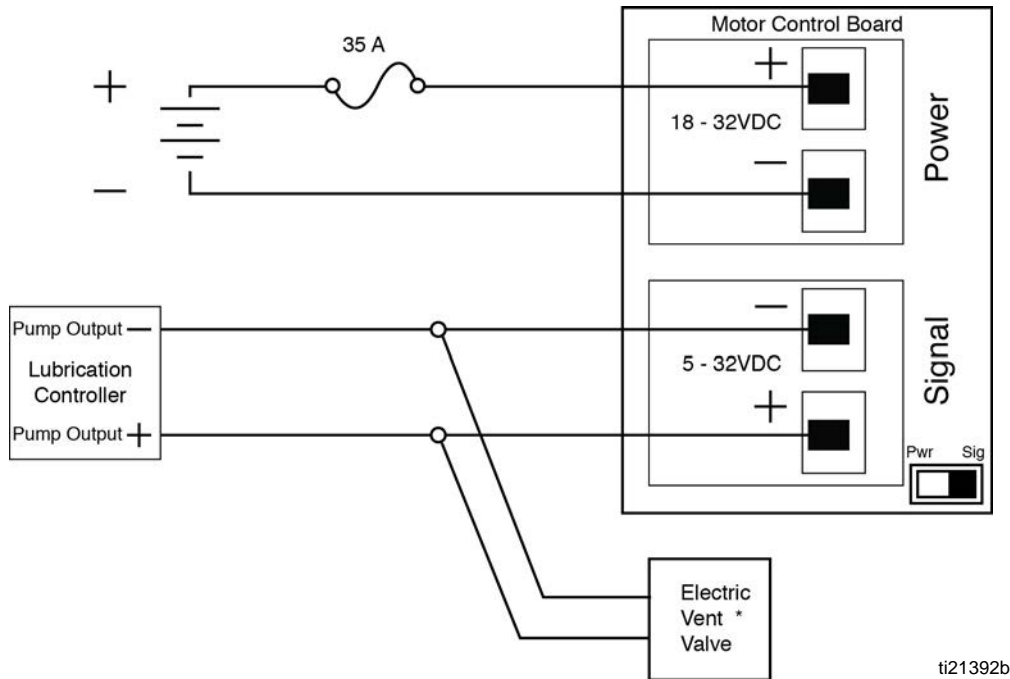

ti21392b

**FIG. 14: Pump control switch shown in signal mode**

*\*A Vent Valve is only used in an injector-based system.*

### 24 VDC With External Relay

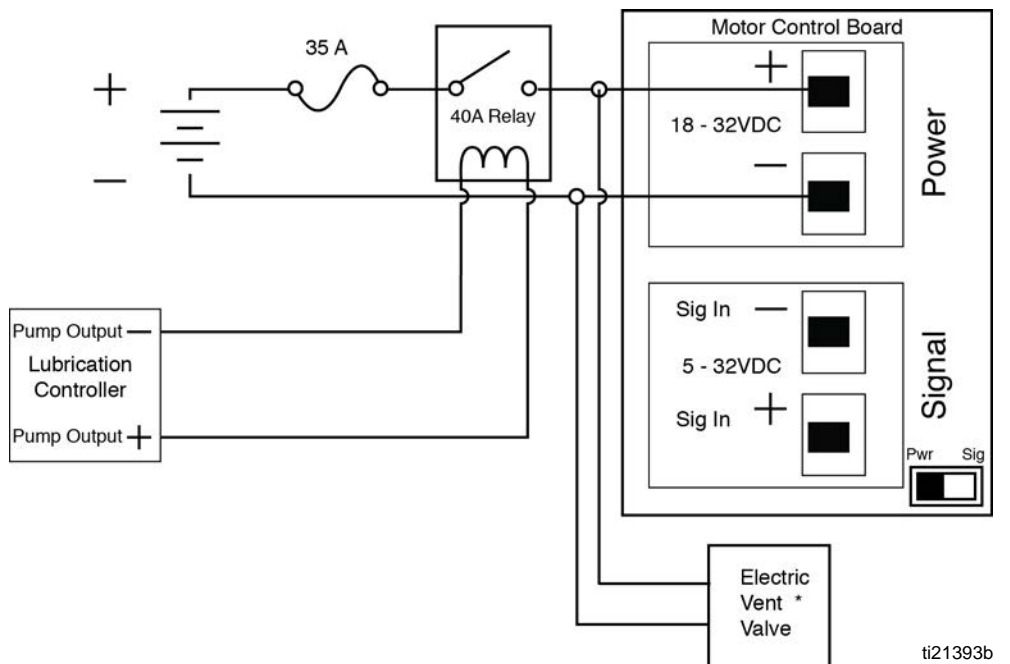

ti21393b

**FIG. 15: Pump controls switch shown in power mode**

*\*A Vent Valve is only used in an injector-based system.*

## DC Models - Motor Control Board

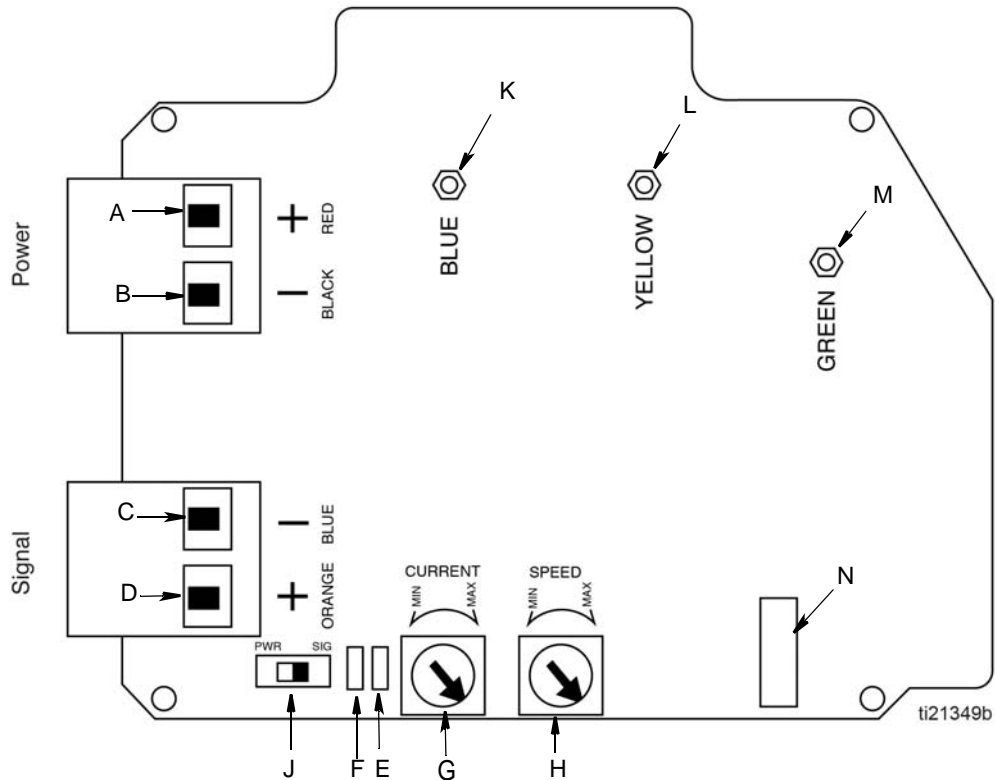

FIG. 16

### Key

- A + (Positive) Power Input
- B - (Negative) Power Input
- C Turn On Signal -
- D Turn On Signal +
- E Red (Fault) LED - Blinks type of fault (See Fault Table)
- F Green (Power) LED -
  - Blinks: Power ON, Pump running
  - Solid: Power/Pump OFF
- G Current Control Potentiometer (Minimum: Turn Knob Counter-Clockwise / Maximum: Turn Knob Clockwise)
- H Flow Control Potentiometer (Minimum: Turn Knob Counter-Clockwise / Maximum: Turn Knob Clockwise)
- J Pump Control Switch\*
  - PWR - Turns pump on when power is applied
  - SIG - Turns pump on when voltage is applied to:
    - SIG IN -
    - SIG IN +
- K Blue Motor Wire Connection
- L Yellow Motor Wire Connection
- M Green Motor Wire Connection
- N J5 Connector - Motor Hall Cable Connector

**\*NOTE:** Be sure power to pump is OFF before switching between the PWR and SIG modes.

### Fault Table: Red LED (E)

| Fault               | Blinks |
|---------------------|--------|
| Over Current        | 1      |
| Locked Rotor        | 2      |
| Low or High Voltage | 3      |
| High Motor temp     | 4      |
| Missing Temp Sensor | 5      |
| High Board Temp     | 6      |
| Bad Hall Cable      | 7      |

### Pump Control Operation

- When the pump control switch is set in signal mode, the motor/pump runs when voltage is applied to the signal and power connectors.
- When the pump control switch is set in power mode, the motor/pump runs when voltage is applied to the power connectors. The signal connectors do not require voltage.

## Current Control and Flow Motor Control Settings

### Current and Flow Control Adjustment

Reference numbers used in the following instructions refer to Parts, page 36.

1. Remove screws (116), cover (120) and gasket (119) to access the control board (FIG. 17).

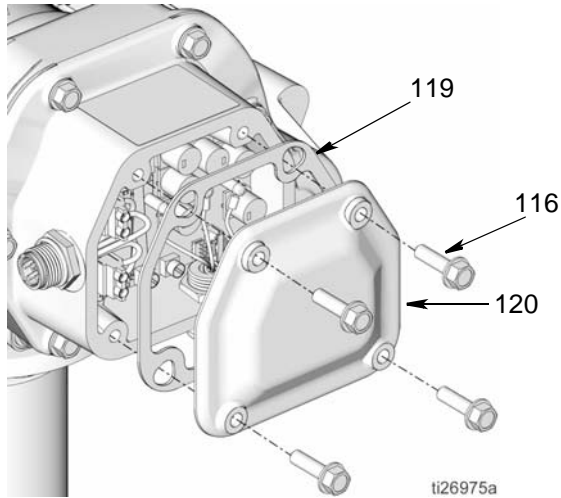
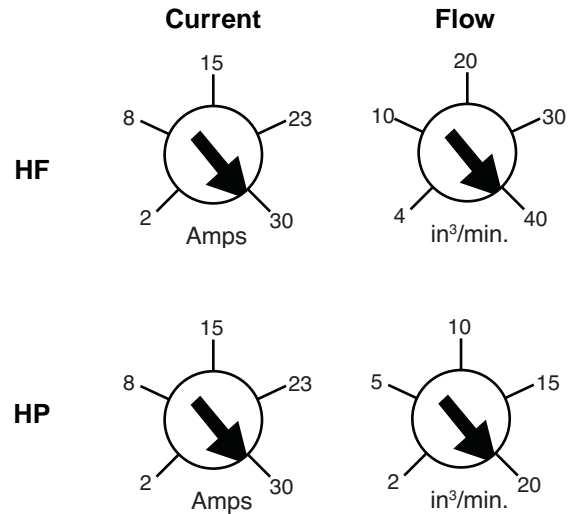

FIG. 17

2. Current and Flow control are adjusted on the Motor Control Board using the Current Control Potentiometer Knob (G) and the Flow Control Potentiometer Knob (H) (page 13). The Current Control knob (G) governs flow. The Current setting has precedence over the Flow Rate setting. You may be limited in achievable Flow Rate by the Current setting.

See Performance Charts, page 41 for Flow Rate and Current information.

- Turn knob clockwise to increase setting value.
- Turn knob counter-clockwise to decrease setting value.







**NOTE:** Values are based on lab test conditions at ambient temperature 72°F (22°C) with an input voltage of 24V. Actual results may vary and should be verified in the application.

3. Replace gasket (119) and cover (120) and screws (116), being careful not to pinch any wires. Tighten bolts securely. Torque bolts to 17-19 ft.-lbs (23-26 N.m).

# Operation



Upper case letters used in the following instructions refer to Typical Installation provided on page 6 or 7.

|  |   |   |   |  |  |  |
|--|---|---|---|--|--|--|
|   |  |  |  |  |  |  |
| <ul style="list-style-type: none"> <li>• Be sure unit is securely mounted and grounded <b>before</b> operation.</li> <li>• Do not lift pressurized equipment.</li> </ul> |   |   |   |  |  |  |





## Priming

1. After reservoir/tank is completely filled, remove high pressure lubricant supply line (D) from the outlet.
2. Connect power to pump.
3. Start pump and run pump until all air has been expelled and fluid flow is continuous.
4. Reconnect the high pressure lubricant supply line (D) to outlet.

## Fill Reservoir

|   |   |  |  |  |  |  |
|---|---|--|--|--|--|--|
|    |  |  |  |  |  |  |
| <p>Do not insert finger into the overflow port while filling a reservoir equipped with a follower plate. Injury or amputation could result.</p> |   |  |  |  |  |  |

|  |  |  |  |  |  |  |
|--|--|--|--|--|--|--|
| <b>NOTICE</b>  |  |  |  |  |  |  |
| <p>To prevent damage to the unit:</p> <ul style="list-style-type: none"> <li>• Check breather (J) vent for proper operation before filling reservoir.</li> <li>• Open overflow port (H) before filling reservoir to visually inspect lubrication level.</li> <li>• Do not fill reservoir beyond overflow port (H).</li> <li>• Do not use breather vent as a port to fill reservoir.</li> </ul> |  |  |  |  |  |  |

|  |  |   |   |  |  |  |
|--|--|---|---|--|--|--|
|   |  |  |  |  |  |  |
| <p><b>COMPONENT RUPTURE HAZARD</b></p> <p>The maximum working pressure of each component in the system may not be the same. Over pressurizing any component can result in rupture, fire, explosion, property damage and serious injury.</p> <p>To reduce the risk of over pressurizing any component in the system, be sure you know the maximum working pressure of each component. <b>Never</b> exceed the maximum working pressure of the lowest rated component in the system.</p> <p>Regulate pressure to the pump so that no fluid line, component or accessory is over pressurized.</p> |  |   |   |  |  |  |

|   |  |
|---|--|
| <b>NOTICE</b>   |  |
| <p>Never allow pump to run dry of the fluid being pumped. Running a pump dry can damage the pump.</p> |  |

## Shutdown

For normal system shut down, disconnect power to lubricator controller (F) and pump (B) to control board.

# Troubleshooting



| Problem  | Cause   | Solution   |   |
|--|---|--|---|
| Pump not powering ON, green LED is not ON  | Wiring not done correctly, polarity is wrong or loose wire(s)                               | Check wire connections. Verify they are all tight. Correct polarity.                         |   |
|  | Fuse not in place or fuse is faulty   | Check fuse rating. If incorrect fuse is used, install fuse of the correct amperage.          |   |
|  | Lubrication controller is in OFF mode   | Set lubrication controller to correct lube cycle.  |   |
| Pump is powered on, green LED is ON but pump is not cycling                                | Motor is not wired properly to control board  | Connect wires to correct color terminals.  |   |
| Pump is powered on, green LED is blinking, pump cycles continuously instead of turning OFF | Pump control switch (J) is set to PWR mode. Pump cycling is not controlled by signal output | Change pump control switch (J) to signal mode (SIG).   |   |
| Pump is cycling but there is no lubricant output from the outlet                           | Lubricant level in tank/reservoir is too low  | Refill tank/reservoir.   |   |
|  | Damaged tank or reservoir   | Replace tank/reservoir.  |   |
|  | Pump is cavitating  |  | Shake tank/reservoir to redistribute grease.                              |
|  |   |  | Install a follower plate to help distribute grease during pump operation. |
|  | Pump seals are worn or damaged  | Replace pump seals. See Seal Replacement instructions, page 19.                              |   |
| Pump is cycling slow   | Current Control Potentiometer Knob (G) on motor control board is set too low                | Increase the current limit by turning the Current Control Potentiometer Knob (G), clockwise. |   |
|  | Flow Control Potentiometer Knob (H) on motor control board is set too low                   | Increase the flow limit by turning the Flow Control Potentiometer Knob (H), clockwise.       |   |
| Pump is cycling, there is output of fluid at the outlet, pump pressure is not building     | Leakage in a lubrication line   | Check lubrication line for leakage. Replace any lines that are leaking and/or damaged.       |   |
|  | Pump seals are worn or damaged  | Replace pump seals. See Seal Replacement instructions, page 19.                              |   |



| <b>Problem</b>                                 | <b>Cause</b>  | <b>Solution</b>   |
|--|---|---|
| Red fault LED (E) on control board, blinking   |   |   |
| Over current fault - 1 blink                   | System pressure too high  | Reduce system pressure by installing larger diameter lubrication tubes  |
|  | Current Control Potentiometer Knob (G) on motor control board is set too low  | Increase the current limit by turning the Current Control Potentiometer Knob (G), clockwise.  |
| Locked rotor - 2 blinks                        | System pressure too high  | Reduce system pressure by installing larger diameter lubrication tubes  |
|  | Current Control Potentiometer Knob (G) on motor control board is set too low  | Increase the current limit by turning the Current Control Potentiometer Knob (G), clockwise.  |
|  | Motor is damaged  | Separate motor from pump and run motor. If motor is damaged, replace motor. See Motor Replacement instructions, page 28.  |
|  | Pump lower is plugged   | Follow Seal Replacement instructions to disassemble pump lower. Inspect and clean parts as needed prior to using them for reassembly. Replace all damaged and worn parts. See Seal Replacement instructions, page 19. |
| Low or high voltage - 3 blinks                 | Faulty input line voltage   | Use a multi-meter to check input line voltage measure 18-32 volts DC.   |
| Motor temperature is high - 4 blinks           | System pressure too high  | Reduce system pressure by installing larger diameter lubrication tubes.   |
|  | Current Control Potentiometer Knob (G) on control board is set too low  | Increase the current limit by turning the Current Control Potentiometer Knob (G), clockwise.  |
|  | Motor is damaged  | Separate motor from pump and run motor. If motor is damaged, replace motor. See Motor Replacement instructions, page 28.  |
|  | Motor control switch (J) is set to PWR mode. Pump cycling is controlled by signal output and pump is running continuously | Change motor control switch (J) to signal mode (SIG).   |
|  | High duty cycle   | Reduce duty cycle.  |
| Missing temperature sensor - blinks - 5 blinks | Loose or damaged HALL sensor cable  | Verify HALL sensor cable is securely attached. Tighten connection. Replace damaged cable.   |
|  | Motor is damaged  | Separate motor from pump and run motor. If motor is damaged, replace motor. See Motor Replacement instructions, page 28.  |

| Problem                                       | Cause   | Solution   |
|---|---|--|
| Control board temperature is high - 6 blinks  | System pressure too high  | Reduce system pressure by installing larger diameter lubrication tubes.  |
|   | Current Control Potentiometer Knob (G) on control board is set too low  | Increase the current limit by turning the Current Control Potentiometer Knob (G), clockwise.                             |
|   | Motor is damaged  | Separate motor from pump and run motor. If motor is damaged, replace motor. See Motor Replacement instructions, page 28. |
|   | Motor control switch (J) is set to PWR mode. Pump cycling is not controlled by signal output and pump is running continuously | Change motor control switch (J) to signal mode (SIG).  |
|   | High duty cycle   | Reduce duty cycle.   |
| Loose or damaged HALL sensor cable - 7 blinks | HALL sensor cable not securely attached   | Verify HALL sensor cable is securely attached. Tighten connection.   |
|   | Damaged HALL sensor cable   | Replace motor.   |
| Motor runs but pump does not                  | Motor shaft/gears are stripped or damaged   | Gear box is damaged. Replace pump.   |
| Control board LED's blink erratically         | Damaged control board   | Replace motor control board. See Motor Control Board Replacement instructions, page 31.                                  |

# Repair

## Seal Replacement

Kits 24T860 - HP Models or 24T861 - HF Models

- Reference numbers used in the following instructions refer to Parts pages beginning on page 35.
- Upper case letters used in the following instructions refer to Typical Installation provided on page 6 or 7.
- Lower case letters used in the following instructions refer to component parts or user provided parts.
- Unless otherwise noted, keep all parts for reassembly. Inspect and clean parts as needed prior to using them for reassembly.
- Use all new parts included in kit for reassembly.



### Disassembly

1. Disconnect Dyna-Star pump from main power source.
2. **Relieve pressure** (see Pressure Relief procedure, page 8).
3. Disconnect Timer/Controller (F) (user supplied, if used).
4. Disconnect High Pressure Lubricant Supply Line (D) to the Lubricant Output Connection (O) (FIG. 11) on the Vent Valve or Manifold.

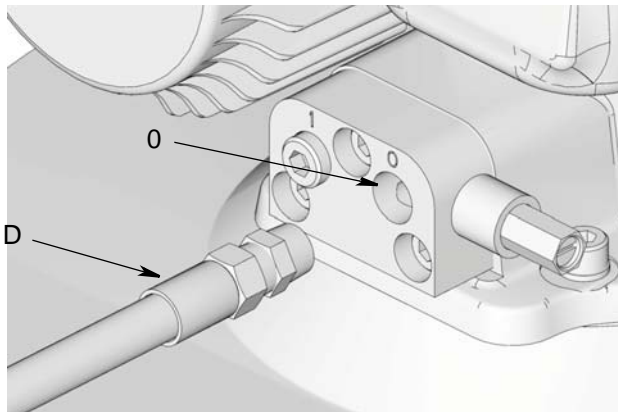

FIG. 18: Lubricant Outlet Connection

5. Loosen bolts (128) and remove cover (126) from Dyna-Star pump (FIG. 19).

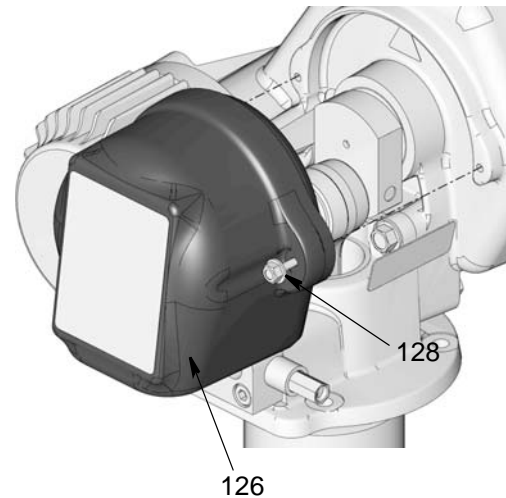

FIG. 19

6. Remove screws (a) and washers (b) holding Dyna-Star Pump to cover and remove pump from cover (FIG. 20). Place pump on a workbench or table top protected with a drop cloth.

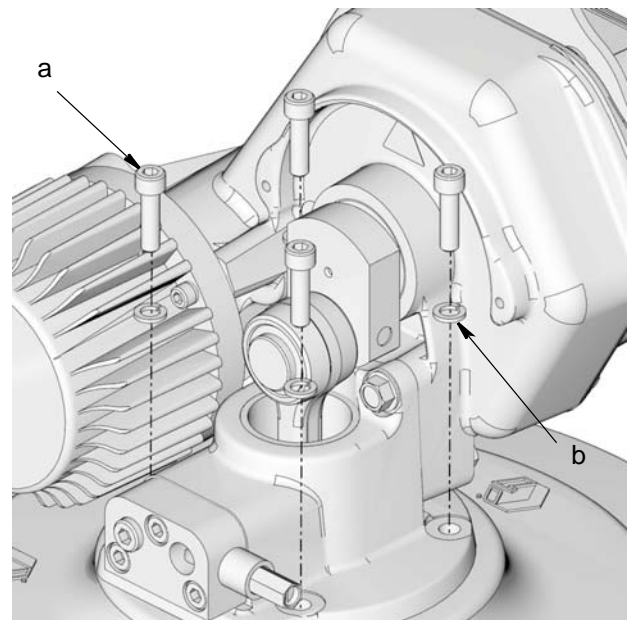
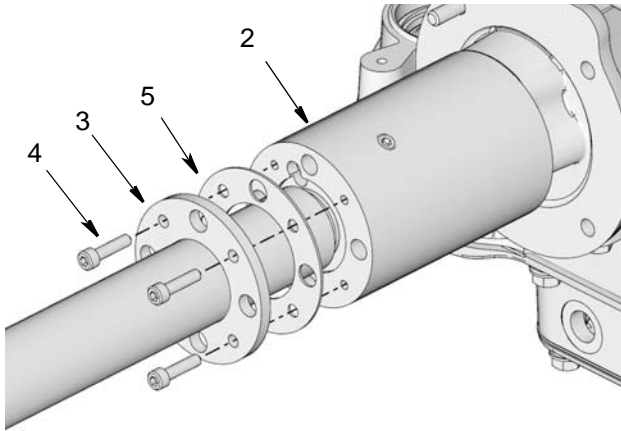

FIG. 20

7. **For Tube-In-Tube models only:** Remove bolts (4) holding tube (3) to pump adapter (2). Remove tube and gasket (5) and set these parts aside to use for reassembly (FIG. 21).



**FIG. 21**

8. Observe location of priming rod (215) and shovel piston (216) inside the shovel cylinder (208) (See Pump Parts, page 38). If the piston is not located in the lowest position inside the cylinder:
  - a. Remove screws (125) and washers (124) holding motor (123) to gear box housing (101) (FIG. 22).
  - b. Remove motor.

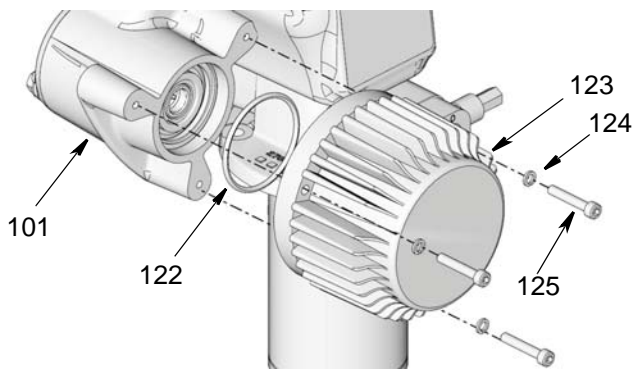
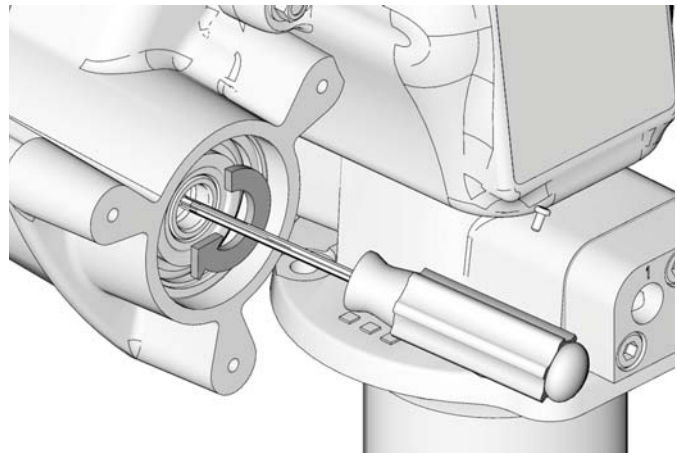

**FIG. 22**

- c. Use a screw driver to turn motor shaft clockwise until shovel piston (216) is seated in the lowest position inside the shovel cylinder (208).

**NOTICE**

Pump has a one way clutch. Do not use a power screwdriver to turn shaft or not turn shaft counter-clockwise. These actions could damage pump/motor.



**FIG. 23**

- d. Verify o-ring (122) is still in place and correctly seated in motor (123) (FIG. 22).
    - e. Reinstall motor (123) to gear housing box (101) using screws (125) and washers (124). Use a wrench to tighten screws securely. Torque to 12 - 14 ft lbs (16 - 19 N.m) (FIG. 22).
9. Remove screws (6) from pump adapter (2) (FIG. 24).

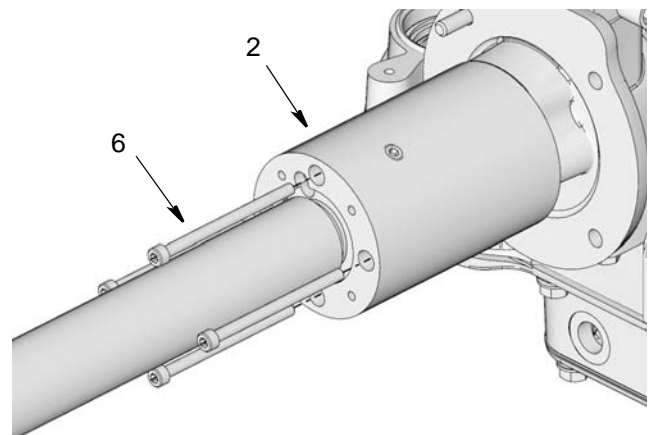

**FIG. 24**

10. Pull pump adapter (2) down to access retaining spring (8) (FIG. 25).

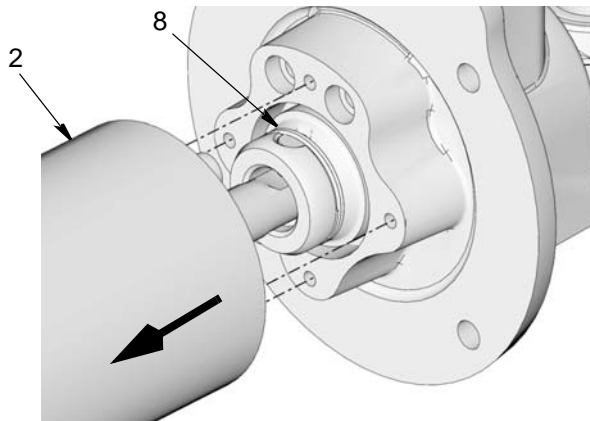

FIG. 25

11. Slide spring (8) out of groove (102a) in connecting rod (102) to expose pump pin (7) (FIG. 26). Push or tap pump pin (7) out of hole.

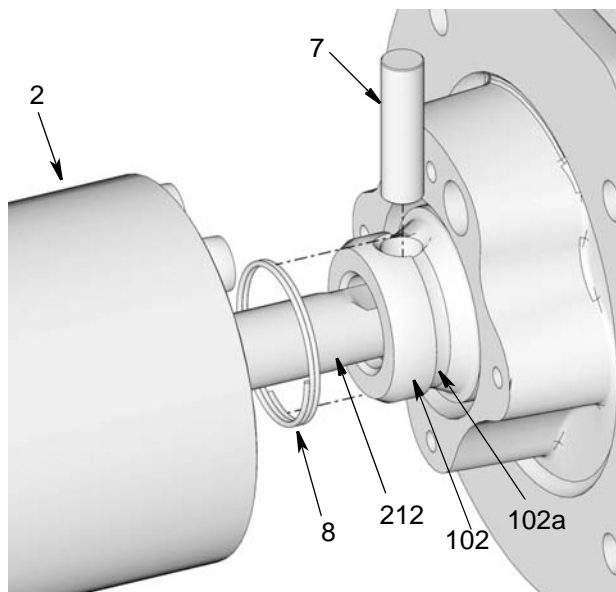

FIG. 26

12. Separate displacement rod (212) from connecting rod (102) and separate these sections. Put section (102) in a safe place. You will need it for reassembly. (FIG. 27).

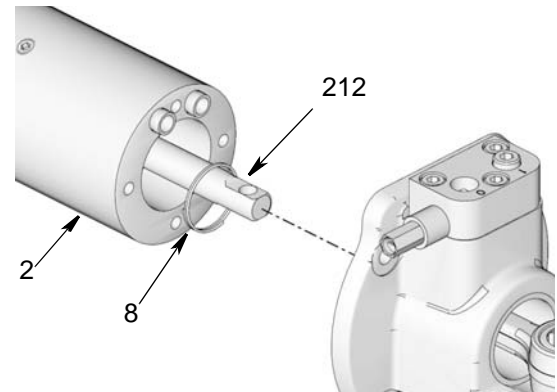

FIG. 27

13. Remove spring (8) and two seals (9). Put spring in a safe place to use it for reassembly. The seals (9) can be discarded. Use the new seals included in the kit for reassembly (FIG. 28).

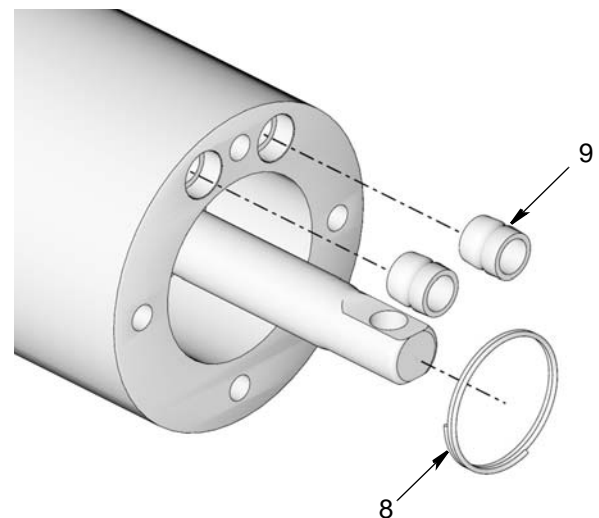

FIG. 28

14. Secure pump adapter (2) section in a brass vise.

**NOTE:** To protect the outside surface of the pump, place a rag around the pump body before putting pump in vise jaws.

15. The pump cylinder is comprised of 3 separate sections. Separate the shovel cylinder section (208) from the pump cylinder (204) first, using two pipe

wrenches, working in opposite directions to loosen shovel cylinder. When cylinder (208) is loose enough, use your hands to unscrew and remove it from the other sections (FIG. 29).

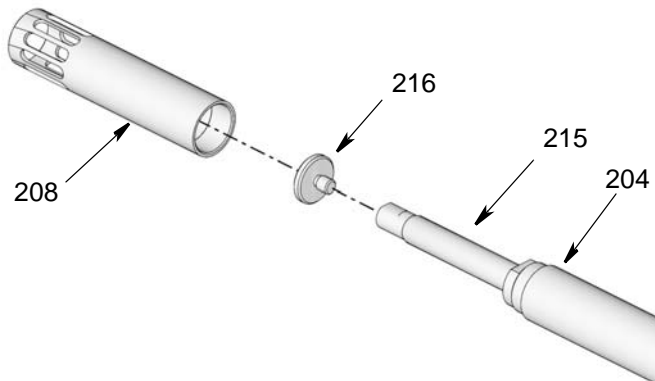

**FIG. 29**

16.

**HP Pump:** Use wrench on flats of priming rod (215) and socket to loosen and remove shovel piston (216) (FIG. 29).

**HF Pump:**

- a. Use wrench on flats of priming rod (215). Remove hex nut (219).
- b. Unscrew shovel (216) and remove it from priming rod (215).

17. Use a wrench on the flats (211a) of seal retainer (211) and a strap wrench working in the opposite direction, on pump cylinder (204), to loosen and remove adapter and o-ring (209) from pump cylinder (204) (FIG. 30). Discard o-ring. Use the new o-ring included in the kit for reassembly.

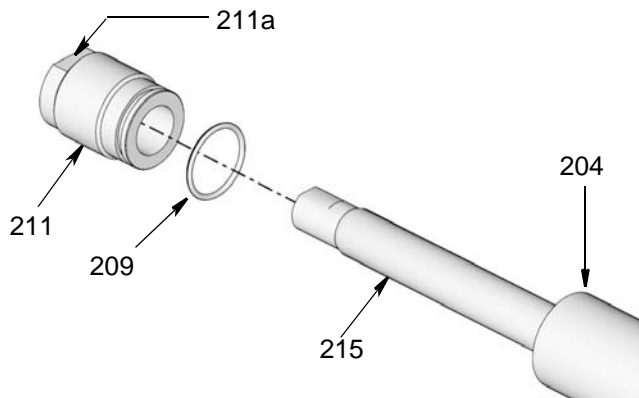

**FIG. 30**

18. Separate pump cylinder (204) from spacer cylinder (205) using two strap wrenches, working in opposite directions to loosen spacer cylinder. When cylinder (204) is loose enough, use your hand to unscrew and remove it from the other section (FIG. 31).

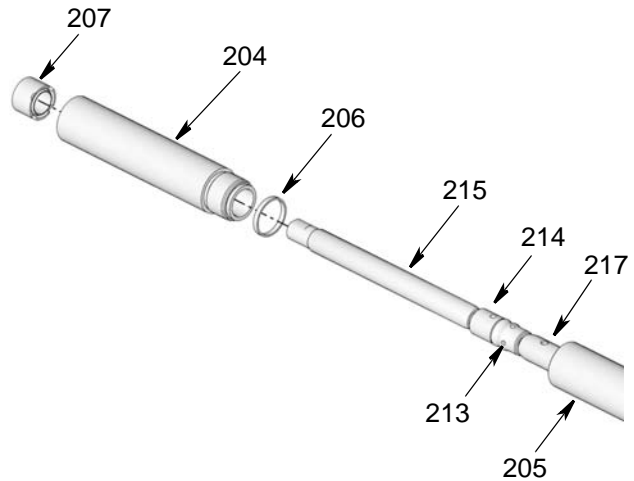

**FIG. 31**

19. Remove intake seal (207) and seal (206). Discard these parts. Use new parts included in the kit for reassembly.

20. Use a hammer or rubber mallet to tap the rod assembly out of the pump adapter (2) in the direction shown in FIG. 32.

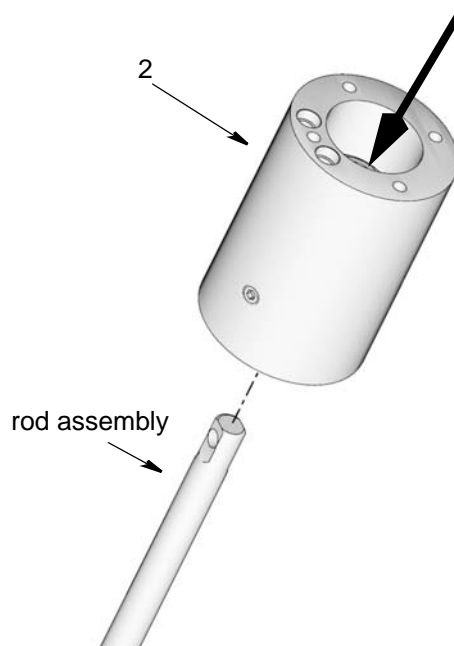

**FIG. 32**

21. Use a punch and hammer to tap out pins (217) holding the rod sections together (FIG. 33). Use your hands to unscrew shovel rod (215) and spacer rod (212) from piston (213).

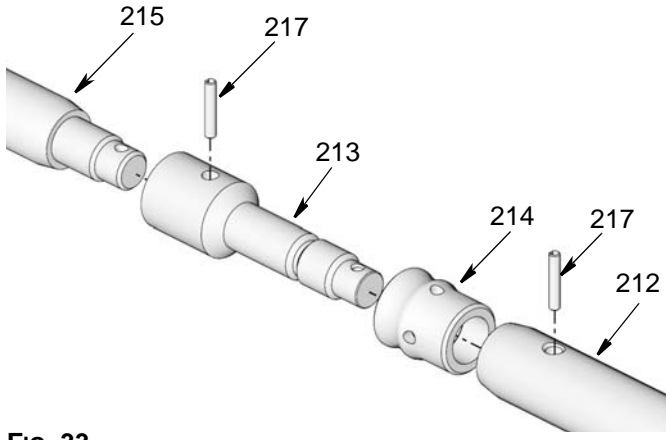

**FIG. 33**

22. Remove piston seal (214) from piston (213). Discard piston seal (214) and pins (217). New replacement parts are included in the kit.
23. Visually inspect rod sections and the inside surface of pump cylinder (204) to verify they are not bent or damaged following disassembly. A pump with bent and/or damaged parts will not hold pressure and/or operate efficiently.
24. Separate spacer cylinder (205) from pump adapter (2) using a strap wrench to loosen cylinder. When cylinder (205) is loose enough, use your hands to unscrew and remove it from the pump.
25. Remove gasket seal (206) from inside pump adapter (2) if it did not come out with the spacer cylinder (205). Discard gasket seal. Use gasket seal included in the kit for reassembly.
26. Use a socket to loosen hex nut (201) and remove it from the pump adapter (2) (FIG. 34).

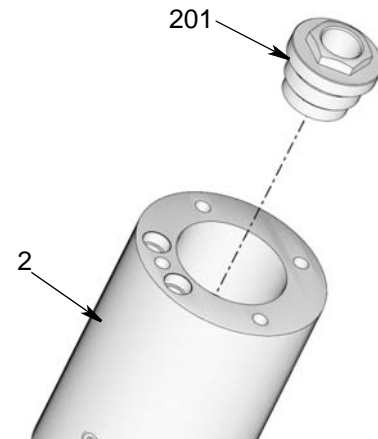

**FIG. 34**

27. Use the displacement rod (212) to push the packing u-cup (202) out of the pump adapter (2) in the direction shown in FIG. 35. Discard u-cup (202). A new one is included in the kit.

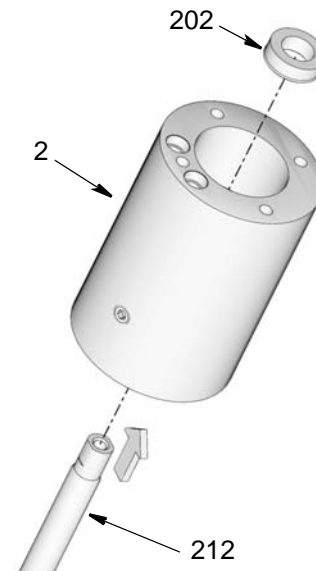

**FIG. 35**

## Reassembly

### NOTE:

- Before reassembly carefully clean and inspect all parts and pump surfaces for scratches and damage. A pump with damaged parts will not hold pressure or operate efficiently.

- Use all new parts included in kit for reassembly.

1. Apply a thin layer of grease to the packing u-cup (202).
2. Use a flat, blunt-end tool to seat u-cup (202), with the lips facing down, into the pump adapter (2) (FIG. 36).

**NOTE:** Do not damage u-cup seal on threads during installation.

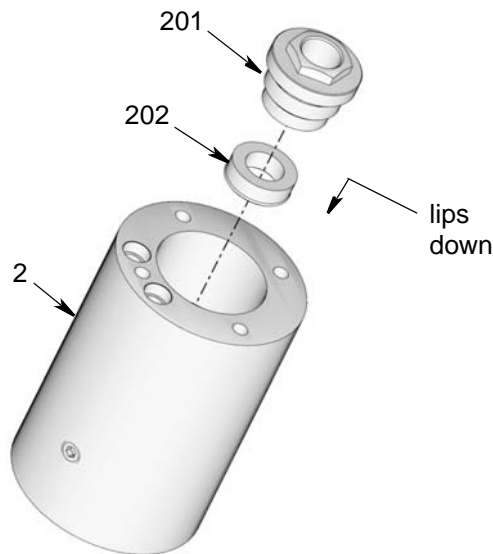
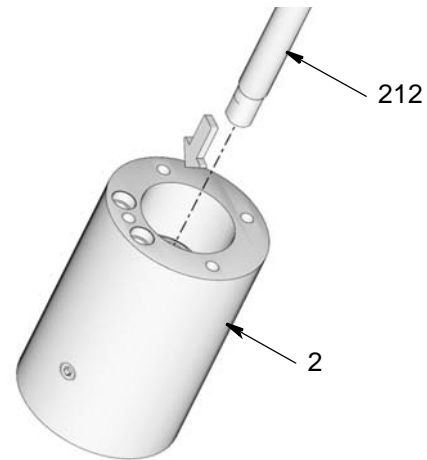

**FIG. 36**

3. Install hex nut (201) inside pump adapter (2). Use a wrench to tighten nut securely (FIG. 36). Torque to 18-22 ft lbs (24 - 30 N.m)
4. Apply a thin layer of grease to the surface of displacement rod (212). Slide rod into the pump adapter (2) in the direction shown in FIG. 37 only.

### NOTICE

Sliding displacement rod (212) into the pump adapter from the other side of the pump adapter (2) could damage the throat seal (201), resulting in a poor seal and fluid leakage during operation.



**FIG. 37**

5. Slide together piston rod (213) and piston seal (214) (FIG. 38).

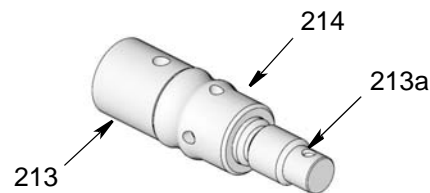

**FIG. 38**

6. Thread piston rod (213) into end of displacement rod (212). Hand tighten the two pieces together securely, ending with hole (213a) (FIG. 38) aligned with hole (212a) (FIG. 39).



- Install pin (217) through the aligned holes [(213a (FIG. 38) and 212a (FIG. 39)]. Support rods (212 and 213) as needed to ensure the rods do not bend. Use a pick and hammer to seat the pin inside the rods.

**NOTE:** Be sure pin is centered in the hole. A pin that is not entirely seated could scratch the bore of the pump cylinder (204) during pump operation; preventing pressure from building and causing fluid to leak.

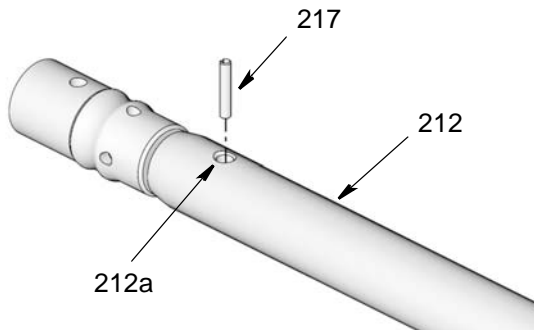

**FIG. 39**

- Thread priming rod (215) into end of piston rod (213). Hand tighten the two pieces together securely, ending with hole (215a) aligned with hole (213b) (FIG. 40).
- Install pin (217) through the aligned holes [215a and 213b (FIG. 40)]. Support rods (215 and 213) as needed to ensure the rods do not bend. Use a pick and hammer to seat the pin inside the rods.

**NOTE:** Be sure pin is centered in the hole. A pin that is not entirely seated could scratch the bore of the pump cylinder (204) during pump operation; preventing pressure from building and causing fluid to leak.

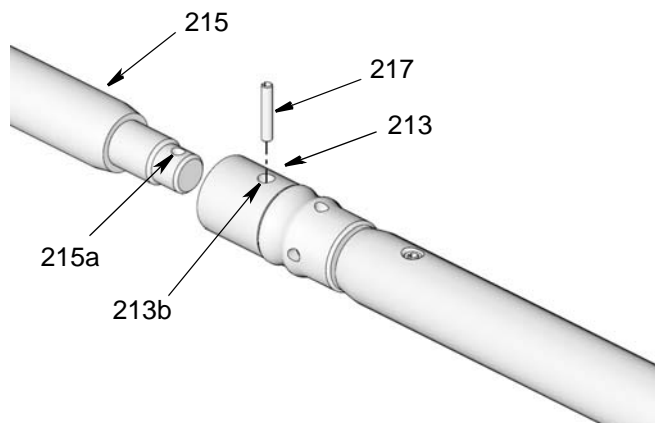

**FIG. 40**

- Apply a thin layer of grease around gasket (206). Install gasket over end of spacer cylinder (205). Slide cylinder over rod assembly as shown in FIG. 41. Thread end of cylinder into bottom of pump adapter (2). Use a pipe wrench to turn cylinder until tightened securely. Torque to 45 - 55 ft lbs (61-74 N.m).

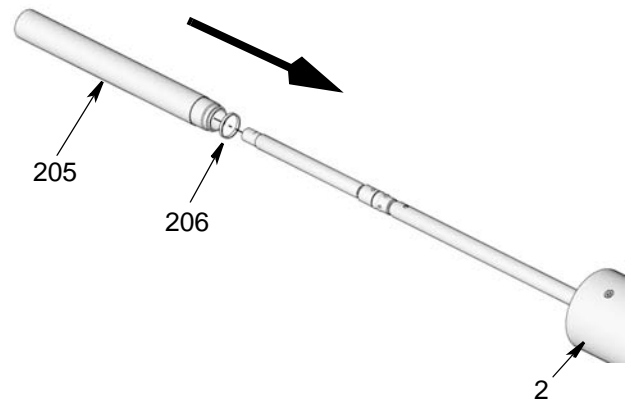

**FIG. 41**

- Apply a thin layer grease to seal (206) and install around pump cylinder (204) (FIG. 42).
- Apply a thin layer of grease to piston seal (214).
- Thread pump cylinder (204) to spacer cylinder (205). Use a wrench to tighten securely. Torque to 45-55 ft lbs (61-74 N.m).
- Apply a thin layer of grease to intake seal (207) and install seal with lips facing up inside pump cylinder (204) as shown in FIG. 42.

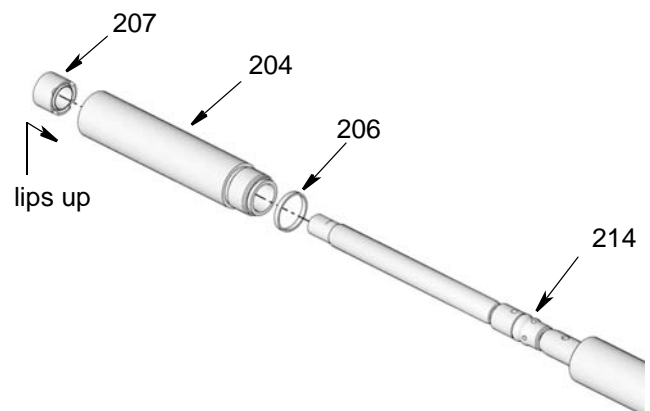

**FIG. 42**

15. Apply a thin layer of grease to o-ring (209) and install around the seal retainer (211) (FIG. 43).
16. Thread seal retainer (211) to pump cylinder (204) with the seal end installed inside the pump cylinder as shown in FIG. 43. Use a wrench on the nut (211a) to tighten adapter nut securely. Torque to 18-22 ft lbs (24 - 30 N.m).

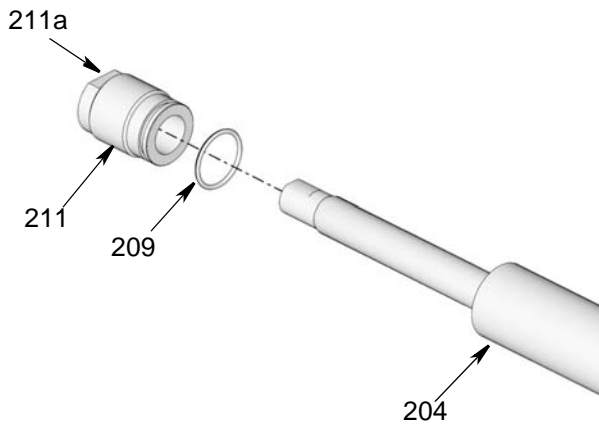

FIG. 43

**HP Pump:** Thread shovel piston (216) to the end of priming rod (215). Use a socket wrench on piston (216) and wrench on the flats of priming rod (215) to securely tighten shovel piston (FIG. 44). Torque to 145 to 155 in. lbs (16 - 17 N.m).

**NOTE:** Be careful when tightening the nut that the rod assembly does not twist and break the support pins (217) or bend any of the rod sections.

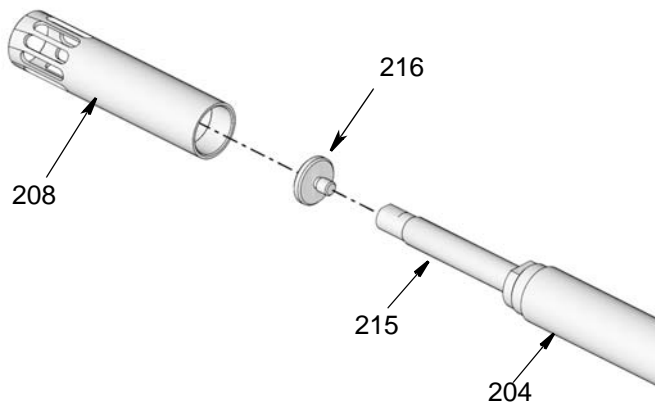

FIG. 44

**HF Pump:**

- a. Thread shovel piston (216) to the end of priming rod (215). Hand tighten.
  - b. Tighten nut using a socket wrench on nut (219) and a second wrench on flats of priming rod (215) turning in the opposite direction.
17. Thread shovel cylinder (208) to pump cylinder (204) (FIG. 44). Use a wrench to tighten securely.
  18. Push displacement rod assembly up until displacement rod (212) is extending out the top of the pump adapter (2) as shown in FIG. 45.
  19. Apply a thin layer of grease to gasket seals (9). Install seals in pump adapter (2) as shown in FIG. 45

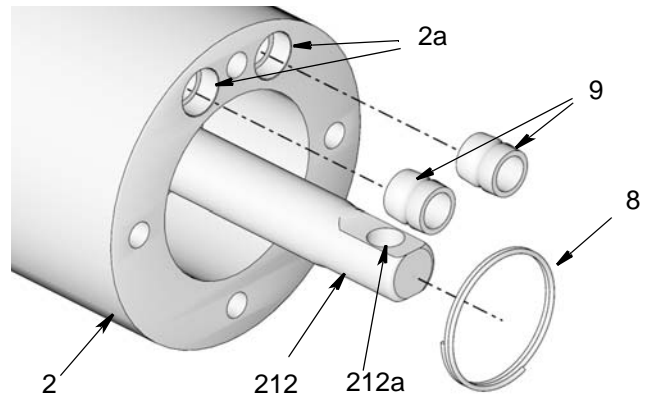

FIG. 45

20. Place spring (8) over the end of displacement rod (212) as shown in FIG. 46.

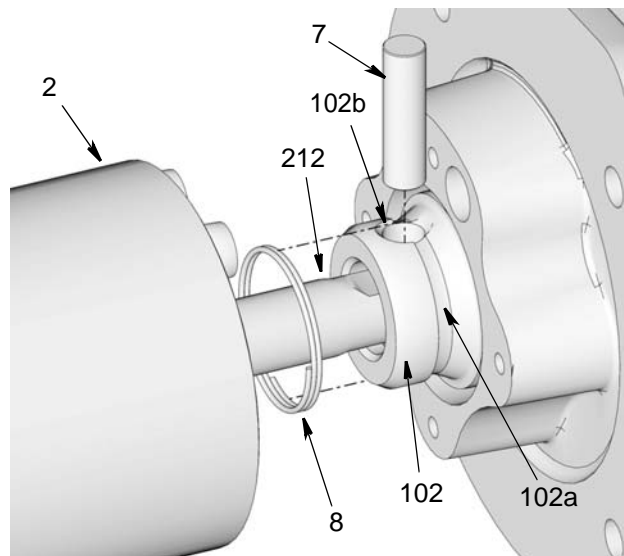

FIG. 46

21. Remove pump assembly from vise. Align hole (212a) in displacement rod (212) (FIG. 45) with connecting rod hole (102b) (FIG. 46). Insert pin (7) through hole.
22. Slide spring (8) over pin (7) to secure pin in place. Seat spring in groove (102a) in connecting rod (102) to prevent it from moving during pump operation.
23. Align the two gasket seals (9) in pump adapter (2) with two holes (103b) in gear box pump bracket (103). Push the pump lower and pump assembly together (FIG. 47).

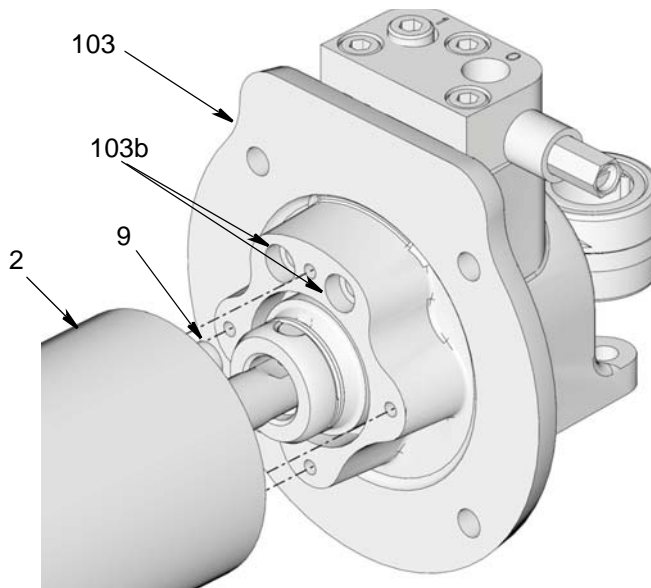

FIG. 47

24. Secure pump adapter (2) to pump upper (pu) using screws (6). Use a socket to tighten screws securely (FIG. 48). Torque to 7-9 ft lbs (9-12 N.m).

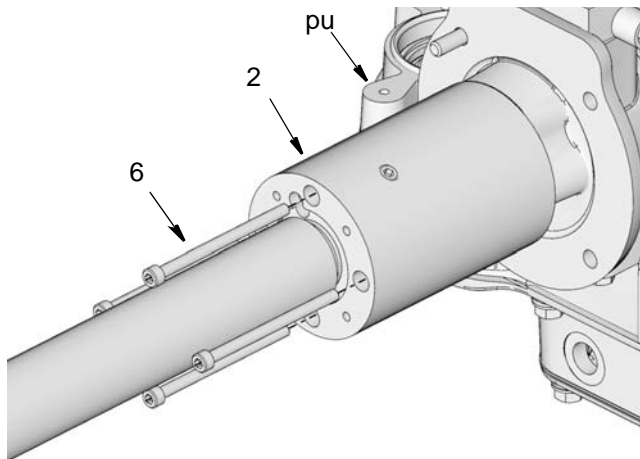

FIG. 48

25. **For Tube-In-Tube models only:** Install gasket (5) and Tube-In-Tube (3). Secure Tube-In-Tube to pump adapter (2) using screws (4). Use a socket to tighten bolts securely (FIG. 49). Torque to 7-9 ft lbs (9-12 N.m).

**NOTE:** *Tube-In-Tube Replacement Kits 24T863 for 60 pound pumps, 24T864 for 90 pound pumps, and 24T865 for 400 pound pumps are available from Graco. See Parts, page 38 for information about ordering these kits or contact your Graco Distributor or Graco Customer Service.*

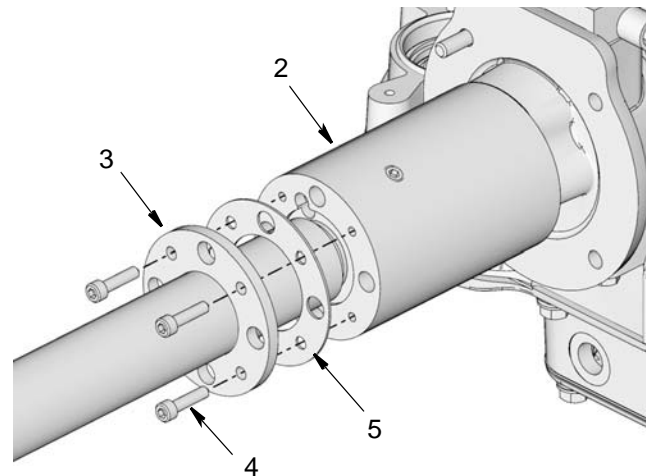

FIG. 49

26. Align holes in pump base with holes in tank / reservoir cover. Securely fasten pump to tank / reservoir cover using screws (a) and washers (b) (FIG. 50).

**NOTICE**

Be careful when installing pump to base that wire harness to motor is not caught between the pump and the hole on top of the reservoir. If the wire harness is caught between the pump and reservoir, the wires could be damaged.

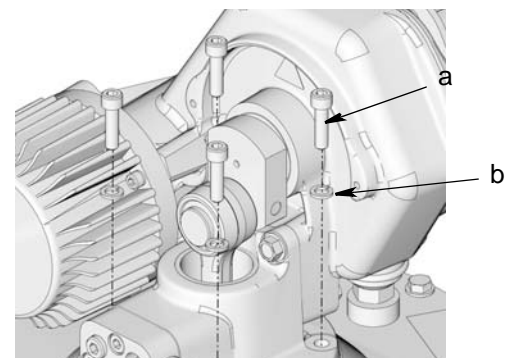
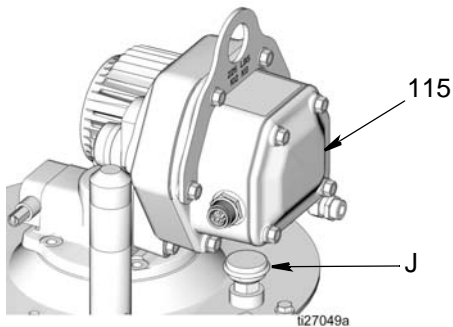

FIG. 50

**NOTE:** When the pump is correctly installed, the breather (J) will be below the control box (115) as shown in FIG. 51.



**FIG. 51**

27. Reinstall cover (126) using bolts (128). Use a wrench to tighten bolts securely (FIG. 52).

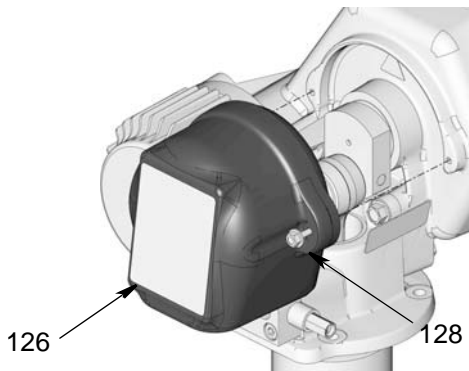

**FIG. 52**

28. Connect the timer/controller (F) (user supplied, if used).

29. Connect High Pressure Lubricant Supply Line (D) to the Lubricant Output Connection (0) (FIG. 53) on the Vent Valve or Manifold.

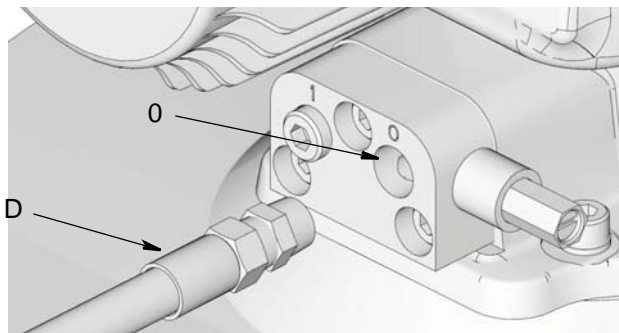

**FIG. 53: Lubricant Outlet Connection**

30. Connect power to pump.

31. See Operation instructions for pump priming and reservoir filling instructions, page 15.

## Motor Replacement: Kit 24T862

- Reference numbers used in the following instructions refer to Parts pages beginning on page 35.
- Upper case letters used in the following instructions refer to Typical Installation provided on page 6 or 7.
- Lower case letters used in the following instructions refer to component parts or user provided parts.
- Unless otherwise noted, keep all parts for reassembly. Inspect and clean parts as needed prior to using them for reassembly.
- Use all new parts included in kit for reassembly.



## Disassembly

1. Disconnect Dyna-Star pump from main power source.
2. **Relieve pressure** (see Pressure Relief procedure, page 8).
3. Disconnect Timer/Controller (F) (user supplied, if used).
4. Disconnect High Pressure Lubricant Supply Line (D) to the Lubricant Output Connection (0) (FIG. 54) on the Vent Valve or Manifold.

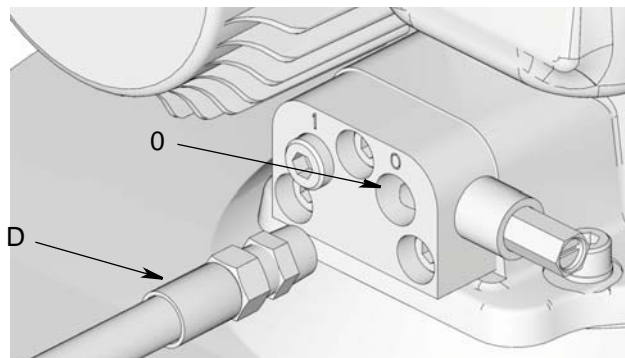

**FIG. 54: Lubricant Outlet Connection**

- Remove screws (116) from motor control box cover (120) and remove cover and gasket (119) (FIG. 55).

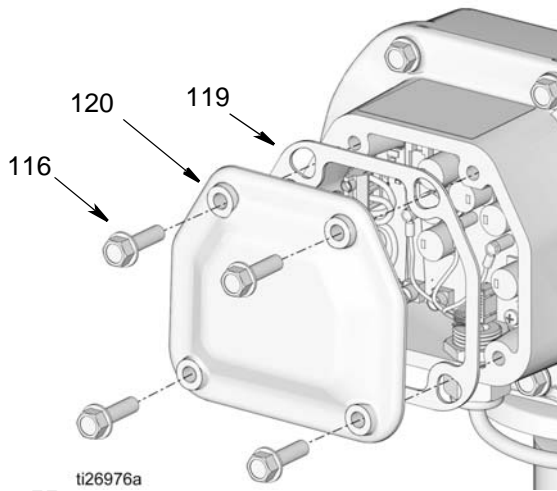

**FIG. 55**

- Remove nuts (134) as shown in FIG. 56. Remove washers (135) and motor wires from terminals. Save these parts to use them for reassembly.

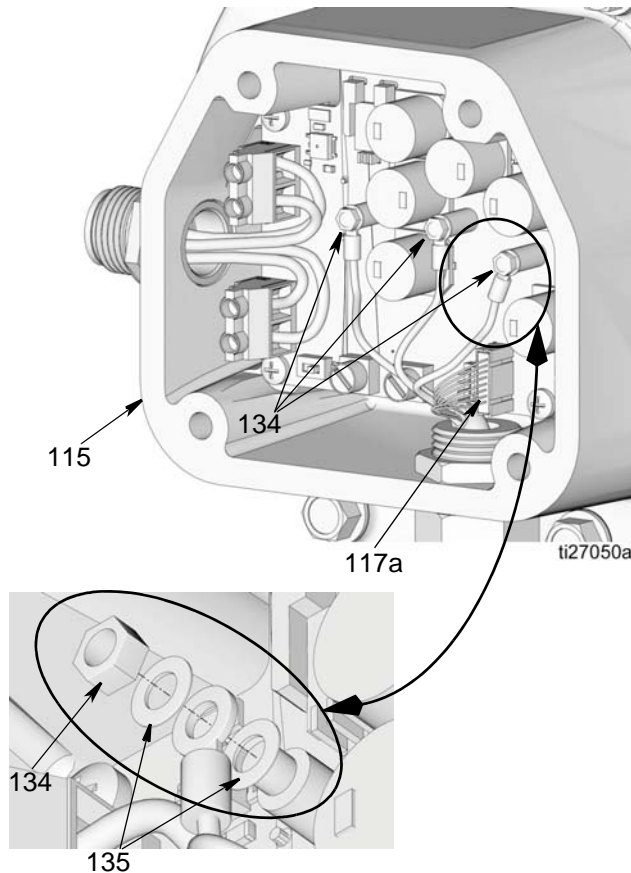

**FIG. 56**

- Disconnect sensor cable (117a) from motor control board (FIG. 56).
- Use a wrench to loosen strain relief (a) and remove wiring harness from housing (FIG. 57).

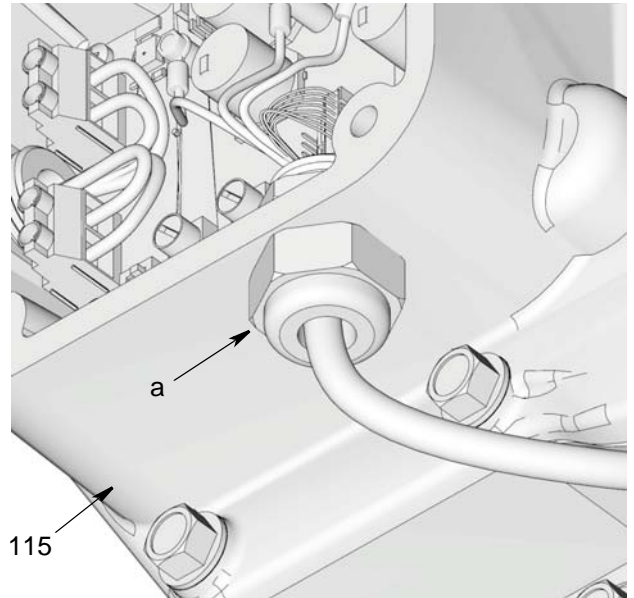
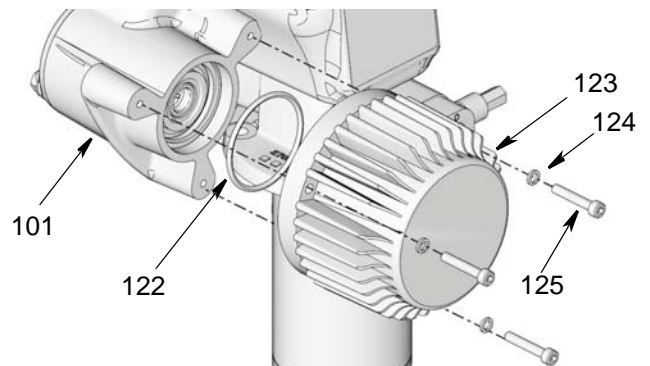

**FIG. 57**

- Remove screws (125) and washers (124) holding motor (123) to gear box housing (101). Remove motor. Verify o-ring (122) was removed with motor. (FIG. 58)

If o-ring (122) is still inside the gear box housing (101), remove it.

Discard these parts in accordance with all safety regulations.



**FIG. 58**

## Reassembly

### NOTE:

- Use all new parts included in kit for reassembly.
1. Apply a thin coating of Gleitmo 585K grease to shaft of the new motor.
  2. Apply a thin layer of grease to o-ring (122). Install o-ring in motor (123) (FIG. 59).

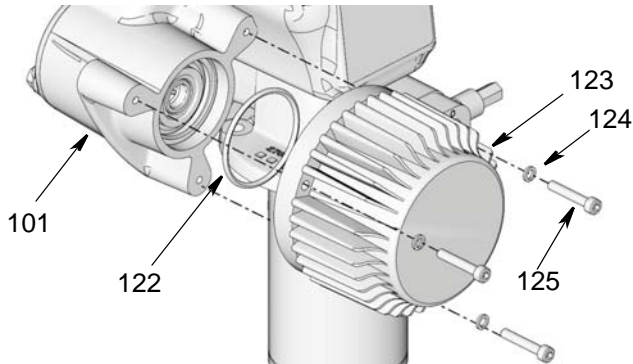

FIG. 59

3. Install new motor (123) using screws (125) and washers (124) (FIG. 59). Use a wrench to tighten screws securely. Torque to 17-19 ft lbs (23 - 25 N.m).
4. Feed motor wire harness (a) through strain relief opening (115a) in housing (115) (FIG. 60).

Thread strain relief body (SR) into opening (115a). Tighten to 3.5 ft.-lbs (4.7 N.m). Tighten coupling nut (CN) to 2.0 ft.-lbs (2.7 N.m).

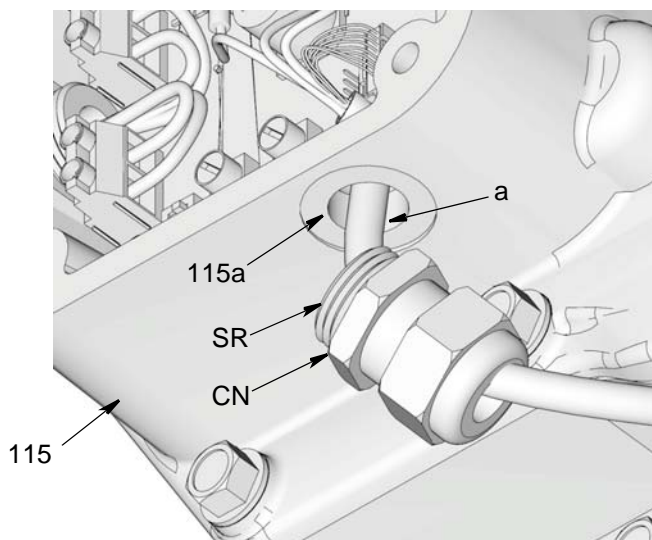

FIG. 60

5. Match green, yellow and blue wires to terminals of same color (written on the motor control board). Secure wires to terminals using washers (134 and 135) (FIG. 61). Torque to 8-10 in. lbs (0.9 - 1.1 N.m).

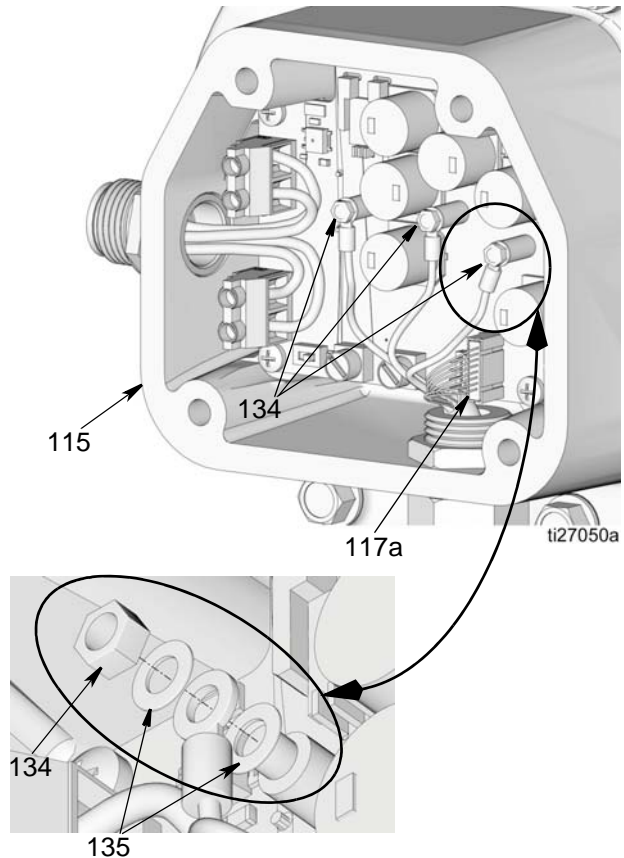
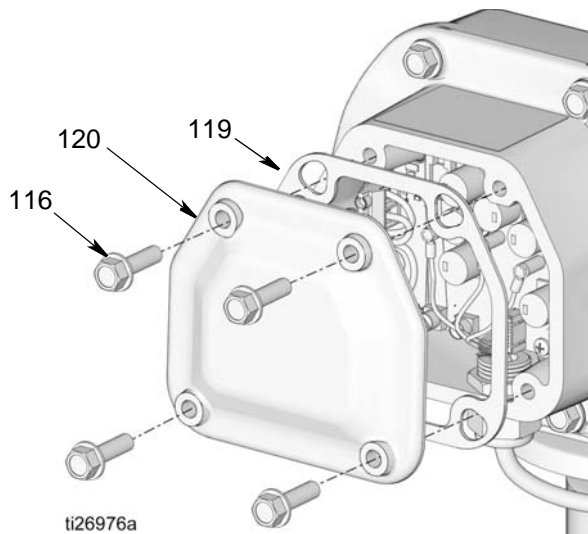

FIG. 61

6. Connect sensor cable (117a) (FIG. 61).
7. Replace control board gasket (119) and cover (120) with screws (116) being careful not to pinch any

wires. Tighten screws securely. Torque to 17-19 ft lbs (23 -25 N.m).



**FIG. 62**

8. Connect the timer/controller (F) (user supplied, if used).
9. Connect High Pressure Lubricant Supply Line (D) to the Lubricant Output Connection (O) (FIG. 63) on the Vent Valve or Manifold.

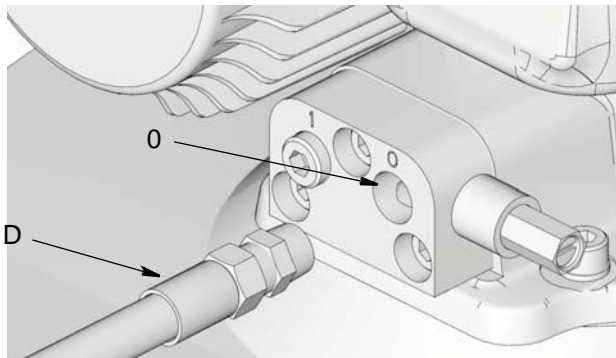

**FIG. 63: Lubricant Outlet Connection**

10. Connect power to pump.
11. See Operation instructions for pump priming and reservoir filling instructions, page 15.

## Motor Control Board Replacement: Kit 24T867

- Reference numbers used in the following instructions refer to Parts pages beginning on page 35.
- Upper case letters used in the following instructions refer to Typical Installation provided on page 6 or 7.
- Lower case letters used in the following instructions refer to component parts or user provided parts.
- Unless otherwise noted, keep all parts for reassembly. Inspect and clean parts as needed prior to using them for reassembly.
- Use all new parts included in kit for reassembly.



### Disassembly

1. Disconnect Dyna-Star pump from main power source.
2. **Relieve pressure** (see Pressure Relief procedure, page 8).
3. Disconnect Timer/Controller (F) (user supplied, if used).
4. Disconnect High Pressure Lubricant Supply Line (D) to the Lubricant Output Connection (O) (FIG. 64) on the Vent Valve or Manifold.

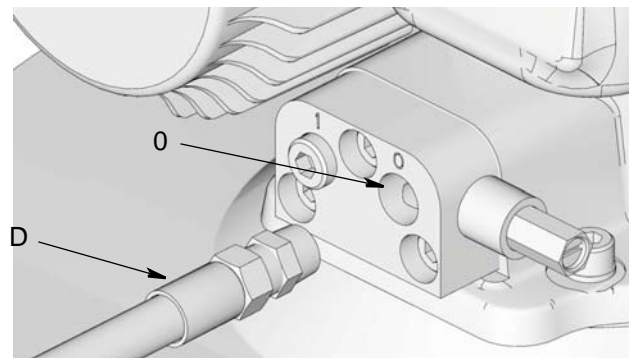

**FIG. 64: Lubricant Outlet Connection**

- Remove screws (116) from motor control box cover (120) and remove cover and gasket (119) (FIG. 65).

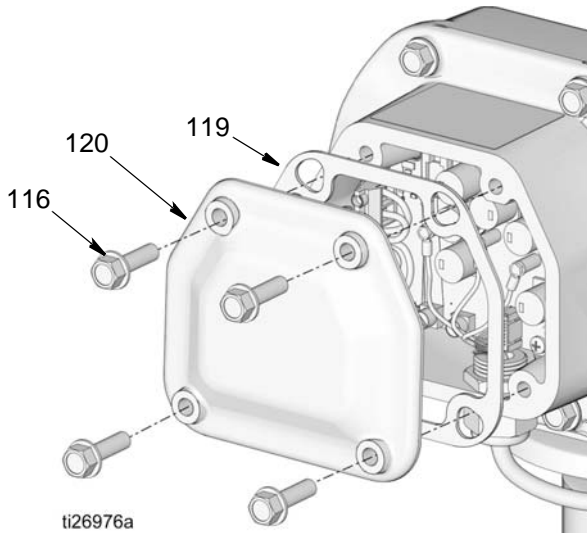

**FIG. 65**

- Remove nuts (134) as shown in FIG. 66. Remove washers (135) and motor wires from terminals.

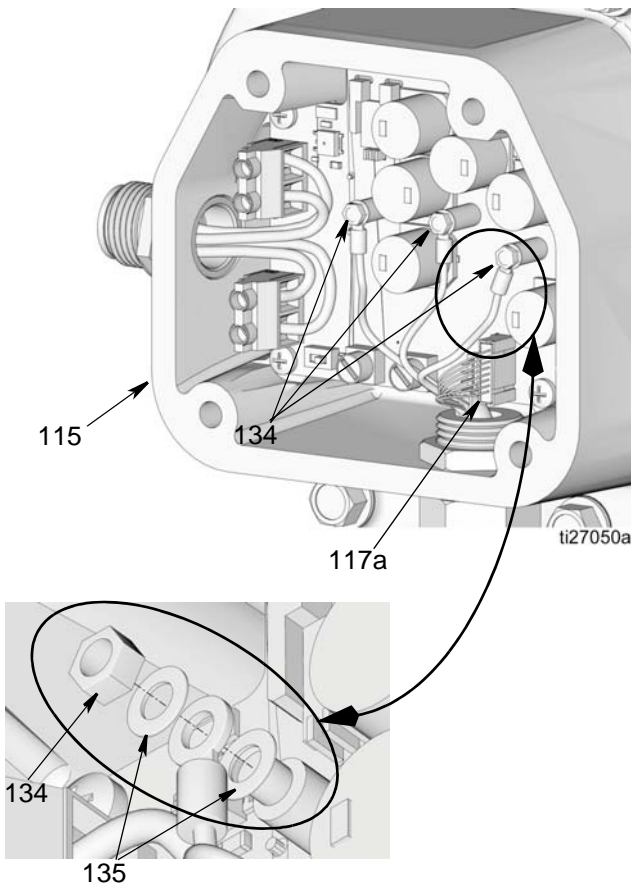

**FIG. 66**

- Disconnect sensor cable (117a) from motor control board (FIG. 67).
- Disconnect source to power input (A and B) and pump control connections (C and D) (See FIG. 67 and Control Panel, page 13).

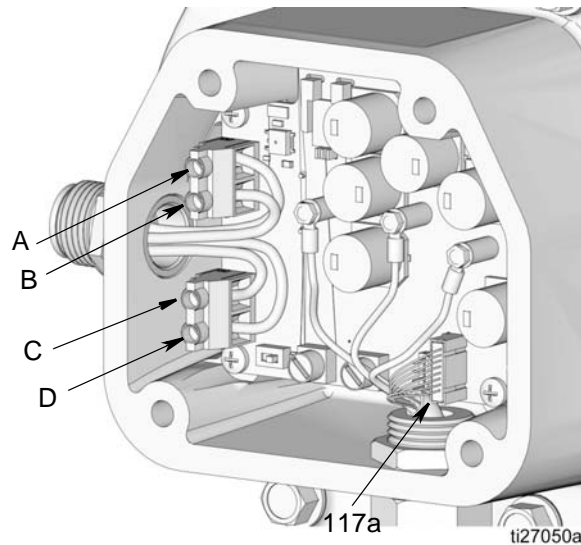

**FIG. 67**

- Remove screws (118) securing motor control board (117) to housing (115) (FIG. 68).

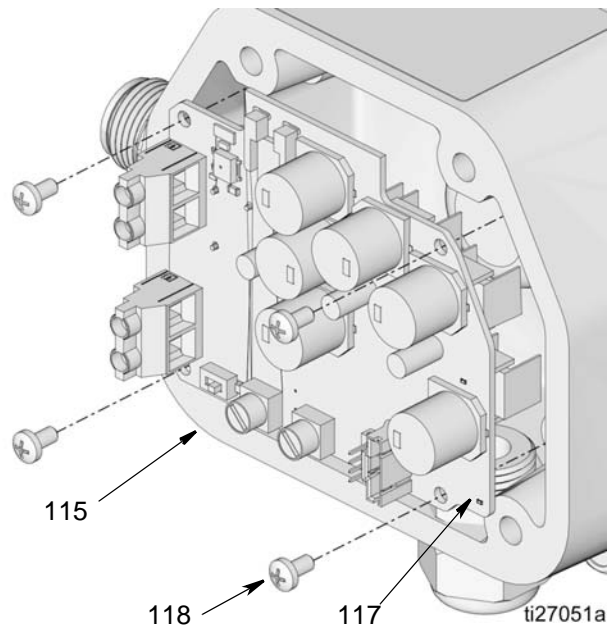

**FIG. 68**

- Remove motor control board from housing and dispose in accordance with all safety regulations.



## Reassembly

### NOTE:

- Use all new parts included in kit for reassembly.
1. Install new motor control board (117) in housing (115) using screws (118) (FIG. 69). Torque to 8 - 10 in. lbs (0.9 - 1.1 N.m).

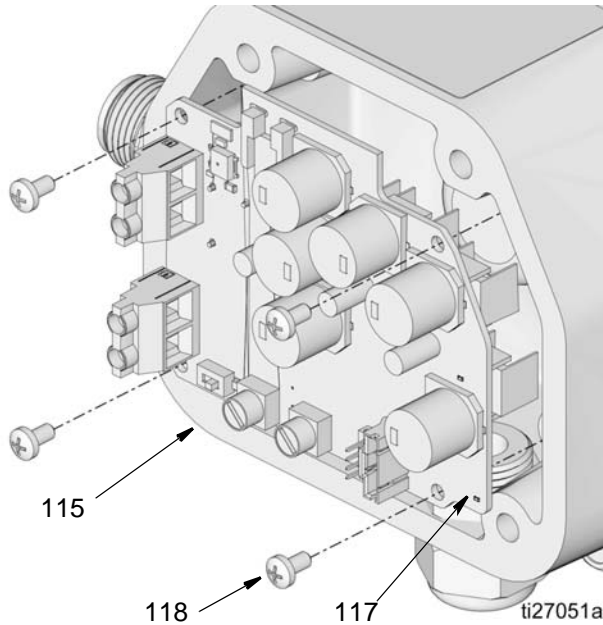

FIG. 69

2. Connect source to power input (A and B) and pump signal connections (C and D) (FIG. 67 and A,B,C,D, page 13). Torque to 5.5 - 7 in. lbs (0.62 - 0.79 N.m).

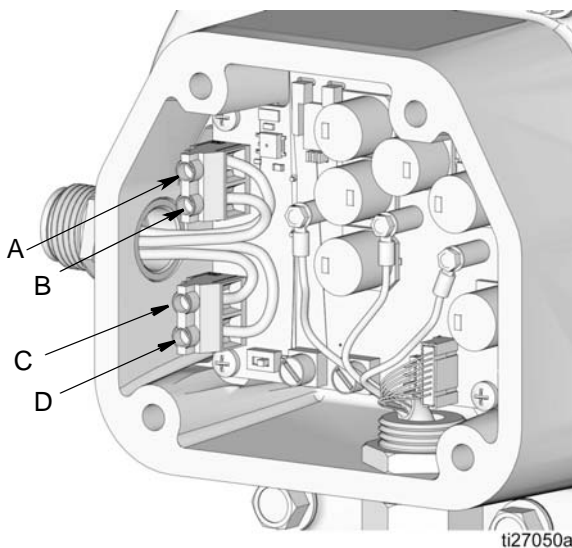

FIG. 70

3. Match green, yellow and blue wires of motor to terminals of same color (written on the control board). Secure wires to terminals using washers (135) and nuts (134) (FIG. 61). Torque to 8 - 10 in. lbs (0.9 - 1.1 N.m).

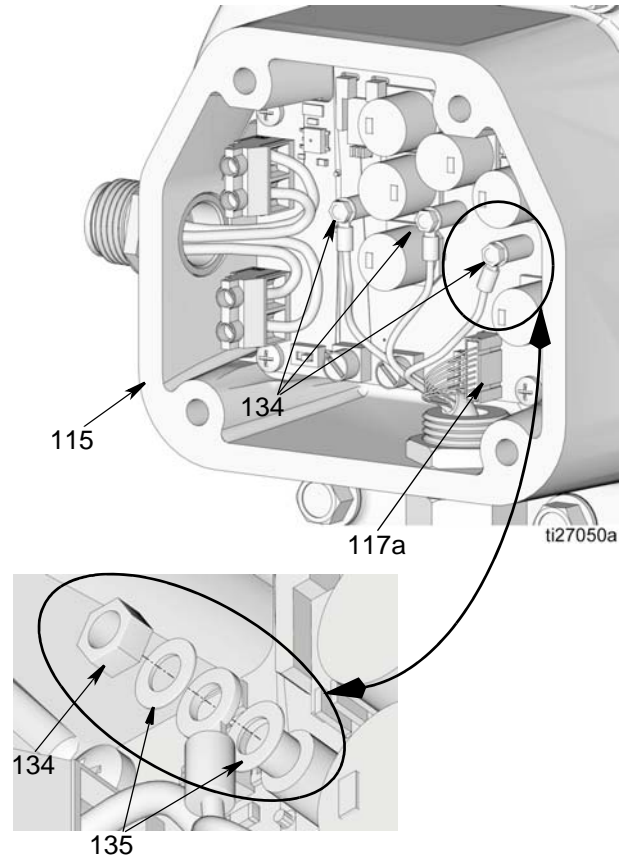
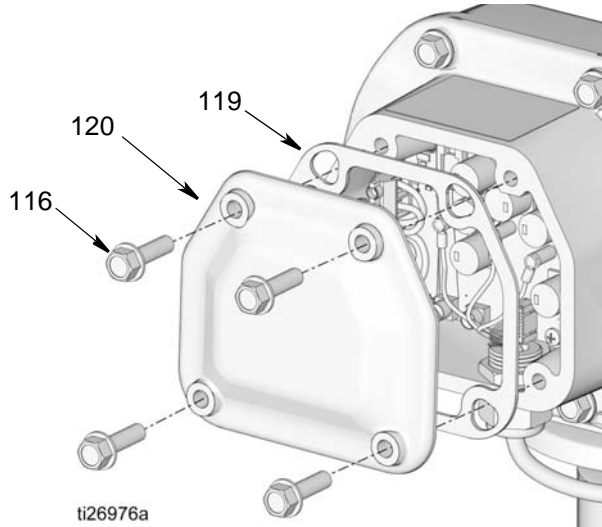

FIG. 71

4. Connect sensor cable (117a) (FIG. 71).

5. Replace motor control board gasket (119) and cover (120) with screws (116) (FIG. 72) being careful not to pinch any wires. Tighten screws securely. Torque to 17 - 19 ft lbs (23 - 25 N.m).



**FIG. 72**

6. Connect the timer/controller (F) (user supplied, if used).
7. Connect High Pressure Lubricant Supply Line (D) to the Lubricant Output Connection (O) (FIG. 73) on the Vent Valve or Manifold.

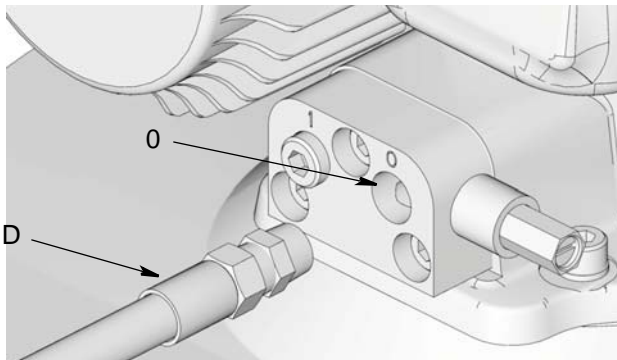

**FIG. 73: Lubricant Outlet Connection**

8. Connect power to pump.
9. See Operation instructions for pump priming and reservoir filling instructions, page 15.

# Parts List

## Main Assembly All Models

| Ref. No. | Part No. | Description   | Qty |
|----------|----------|---|-----|
| 1        |          | BOX, gear, model (page 36)  | 1   |
| 2        | 24T897   | KIT, adapter, pump, HP models   | 1   |
|          | 24T898   | KIT, adapter, pump, HF models   | 1   |
| 3        | ★        | TUBE-IN-TUBE, 60#, includes 4, model 77X001, 77X011   | 1   |
|          | ★        | TUBE-IN-TUBE, 120#, includes 4, model 77X002, 77X012  | 1   |
|          | ★        | TUBE-IN-TUBE, 400#, includes 4, model 77X003, 77X013  | 1   |
| 4        | ★        | SCREW, shcs M6 x 25, models 77X001, 77X002 and 77X003   | 4   |
| 5        | ★        | GASKET, fill tube flange, models 77X001, 77X002, 77X003, 77X011, 77X012, 77X013   | 1   |
| 6        |          | SCREW, shcs, M6-1.0X90 SST  | 4   |
| 7        | 15F856   | PIN, pump   | 1   |
| 8        | 119778   | SPRING, retaining   | 1   |
| 9        | ◆†       | GASKET, seal  | 2   |
| 11       | ✿        | ADAPTER, outlet, models 77X000, 77X001, 77X002, 77X003, 77X014, 77X015, 77X016  | 1   |
| 12       | ✿@       | O-RING, -014 FKM 75 Duro  | 2   |
| 13       | ✿        | SCREW, cap, models 77X000, 77X001, 77X002, 77X003, 77X014, 77X015, 77X016   | 3   |
|          | @        | SCREW, cap, models 77X011, 77X012, 77X013, included in kit 77X540   | 3   |
| 14       |          | LABEL, name, serial   | 1   |
| 15       | ✿@       | PLUG, pipe  | 1   |
| 16       | 16V999   | VALVE, pressure relief, 5000 psi (34.47 MPa, 344 bar), models 77X000, 77X001, 77X002, 77X003,                                     | 1   |
|          | 115122 @ | VALVE, pressure relief, 4000 psi (27.6 MPa, 276 bar), models 77X011, 77X012, 77X013, 77X014, 77X015, 77X016                       | 1   |
| 18       | 77X540   | KIT, vent valve, also includes 12, 13, 15, 16, 17; included with models 77X011, 77X012, 77X013 only. Can be added to other models | 1   |
| 19       | 24T862   | KIT, motor replacement  | 1   |
| 29▲      | 16U728   | LABEL, safety, warning  | 1   |
| 30▲      | 15H108   | LABEL, safety, pinch  | 2   |
| 31       | 77X551   | KIT, connector, front mount   | 1   |
| 33       |          | ASSEMBLY, pump lower (see page 37 and 38)   | 1   |

★ Included in Tube-In-Tube Kit 24T863 (60 pound), 24T864 (90 pound), 24T865 (400 pound).  
 ◆ Included in Seal Kit 24T860.  
 † Included in Seal Kit 24T861.  
 ✿ Included in Outlet Manifold Kit 16X171.  
 @Included in Vent Valve Kit 77X540.

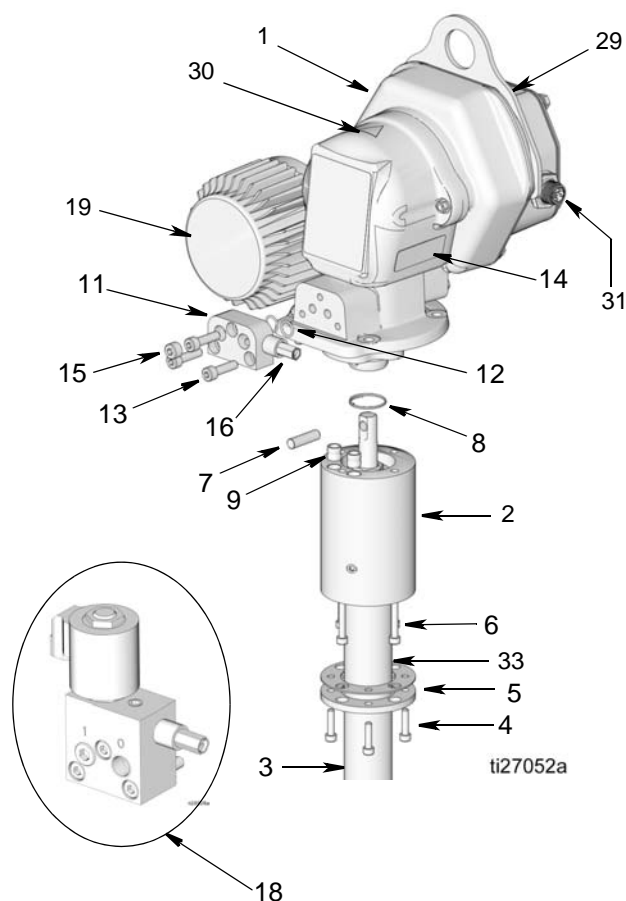

▲ Replacement Danger and Warning labels, tags, and cards are available at no cost.

# Gear Box

| Ref. No. | Part No. | Description                       | Qty |
|----------|----------|-----------------------------------|-----|
| 31       | 77X551   | KIT, connector, front mount       | 1   |
| 101      |          | HOUSING, gear box                 | 1   |
| 102      |          | ROD, connecting                   | 1   |
| 103      |          | BRACKET, gear box to pump         | 1   |
| 104      |          | SCREW, M8                         | 2   |
| 105      |          | BOLT, M8                          | 2   |
| 112      |          | PACKING, o-ring                   | 1   |
| 113      |          | GEAR, first stage, w bearing      | 1   |
| 114      |          | RING, retaining, internal         | 1   |
| 115      |          | HOUSING, gear                     | 1   |
| 116      | \$       | SCREWS, M8                        | 11  |
| 117      | *        | BOARD, control                    | 1   |
| 118      | *        | SCREW, machine, phillips pan head | 4   |
| 119      | \$       | SEAL, control box cover           | 1   |
| 120      | \$       | COVER, control box                | 1   |

|     |         |                      |   |
|-----|---------|----------------------|---|
| 122 | 162841✓ | PACKING, o-ring      | 1 |
| 123 | ✓       | MOTOR, 24VDC         | 1 |
| 124 | ✓       | WASHER, lock         | 3 |
| 125 | ✓       | SCREW, cap, hex head | 3 |
| 126 | ❖       | COVER, shroud        | 1 |
| 128 | ❖       | BOLT, M6             | 2 |
| 133 |         | RING, lift plate     | 1 |
| 134 | *       | NUT                  | 3 |
| 135 | *       | WASHER               | 6 |

\* Included in Control Board Kit 24T867.

❖ Included in Shroud Kit 24T866.

✓ Included in Motor Kit 24T862

\$ Included in Motor Control Board Seal Kit 17H538

**NOTE:** Kit 17H538 only includes quantity 4 - #116 Screws.

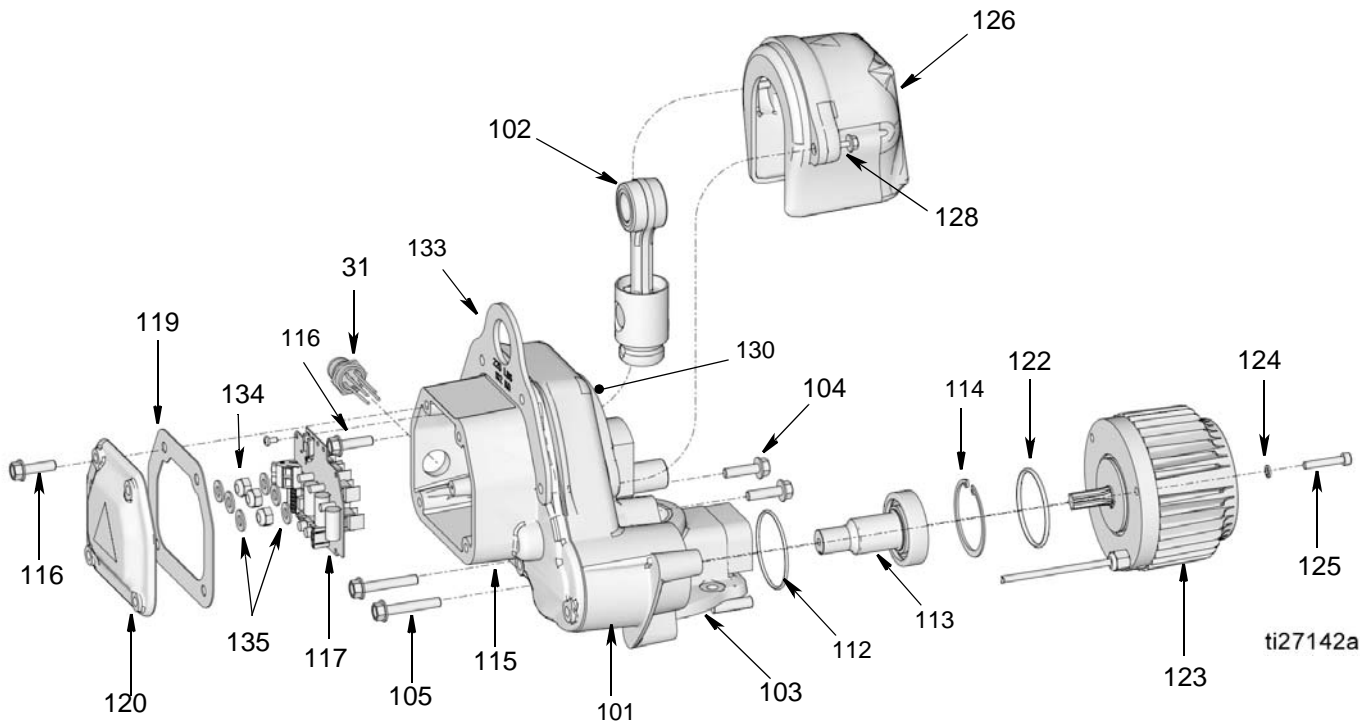

## HP Model Pump Lower: 16T857, 16N700, 16T757

| Ref. No. | Part No. | Description                               | Qty |
|----------|----------|---|-----|
| 2        | 24T897   | KIT, adapter, pump                        | 1   |
| 201      | 15C530   | NUT, retainer                             | 1   |
| 202      | ◆        | PACKING, u-cup, throat, hp                | 1   |
| 204      | 15C537   | CYLINDER, pump                            | 1   |
| 205      | 16N718   | CYLINDER, spacer, 35/60# (model 16T857)   | 1   |
|          | 16N686   | CYLINDER, spacer, 90/120# (model 16N700)  | 1   |
|          | 16T753   | CYLINDER, spacer, 400# (model 16T757)     | 1   |
| 206      | ◆        | GASKET, seal                              | 2   |
| 207      | ◆        | SEAL, intake                              | 1   |
| 208      | 192539   | CYLINDER, shovel                          | 1   |
| 209      | ◆        | O-RING                                    | 1   |
| 211      | ◆        | SEAL, retainer                            | 1   |
| 212      | 16N719   | ROD, displacement, 35/60# (model 16T857)  | 1   |
|          | 16N687   | ROD, displacement, 90/120# (model 16N700) | 1   |
|          | 16T754   | ROD, displacement, 400# (model 16T757)    | 1   |
| 213      | 15G098   | ROD, piston                               | 1   |
| 214      | ◆        | SEAL, piston                              | 1   |
| 215      | 15F296   | ROD, shovel, 225, hp                      | 1   |
| 216      | 16W249   | PISTON, shovel, 50:1 hp                   | 1   |
| 217      | ◆        | PIN, straight                             | 2   |

◆ Included in Seal Kit 24T860.

## HF Model Pump Lower: 16T706, 16T821, 16T822

| Ref. No. | Part No. | Description                               | Qty |
|----------|----------|---|-----|
| 2        | 24T898   | KIT, adapter, pump                        | 1   |
| 201      | 16F947   | NUT, retainer                             | 1   |
| 202      | †        | PACKING, u-cup                            | 1   |
| 204      | 16F774   | CYLINDER, pump                            | 1   |
| 205      | 16T704   | CYLINDER, 90/120#, spacer (model 16T706)  | 1   |
|          | 16T818   | CYLINDER, spacer, 400# (model 16T821)     | 1   |
|          | 16T819   | CYLINDER, spacer, 35/60# (model 16T822)   | 1   |
| 206      | †        | GASKET                                    | 2   |
| 207      | †        | SEAL, intake                              | 1   |
| 208      | 16F775   | CYLINDER, shovel                          | 1   |
| 209      | †        | O-RING                                    | 1   |
| 211      | †        | SEAL, retainer                            | 1   |
| 212      | 16T703   | ROD, displacement, 90/120# (model 16T706) | 1   |
|          | 16T810   | ROD, displacement, 400# (model 16T821)    | 1   |
|          | 16T811   | ROD, displacement, 35/60# (model 16T822)  | 1   |
| 213      | 16F771   | ROD, piston, 50:1                         | 1   |
| 214      | †        | SEAL, piston                              | 1   |
| 215      | 16F943   | ROD, priming                              | 1   |
| 216      | 16F944   | PISTON, shovel, 50:1 hp                   | 1   |
| 217      | †        | PIN, straight                             | 2   |
| 219      | 16C022   | NUT, hex                                  | 1   |

† Included in Seal Kit 24T861.

## Pump Lower Parts

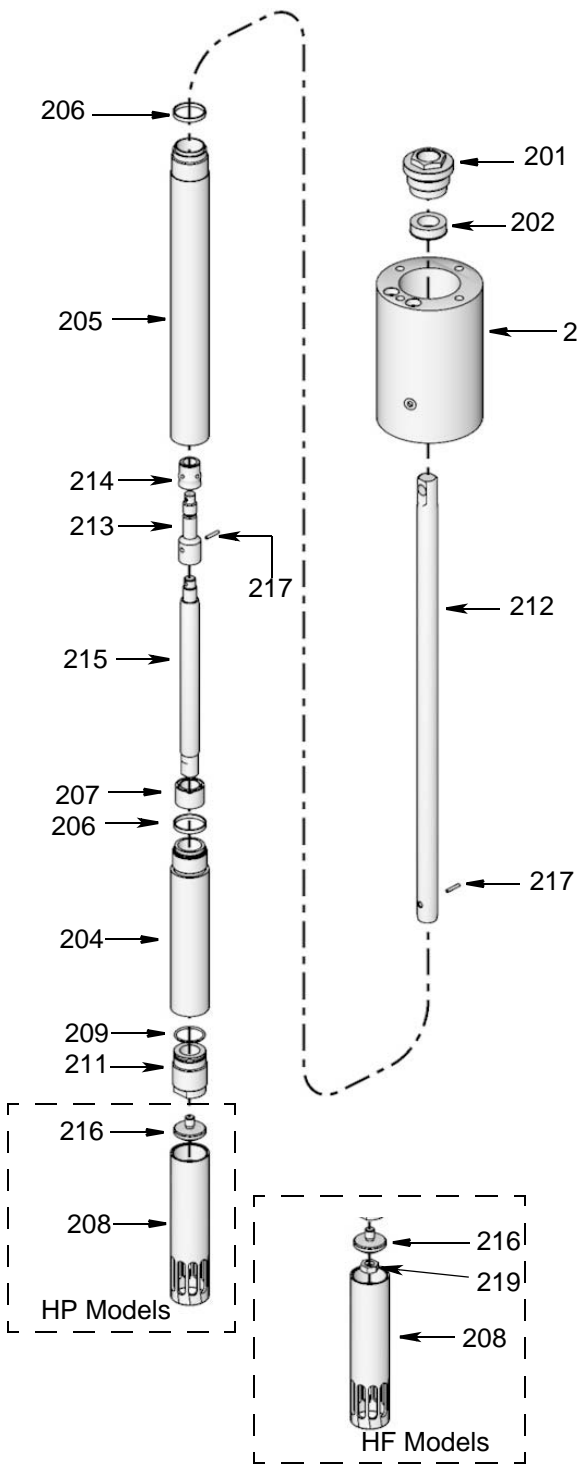

## Cable Harness Kits

| Part No. | Description   |
|----------|---|
| 77X545   | CABLE, power, straight, 15 feet. Use with 77X551                  |
| 77X546   | CABLE, power, straight, 15 feet, with vent valve. Use with 77X551 |
| 24N402   | CABLE, 6 ft, vent valve, 2 pin for vent valve control             |
| 77X551   | KIT, connector, front mount                                       |

## Repair Kits

| Part No. | Description                    |
|----------|--------------------------------|
| 24T860   | KIT, seal, HP models           |
| 24T861   | KIT, seal, HF models           |
| 24T862   | KIT, motor replacement         |
| 24T863   | KIT, tube-in-tube, 60 pound    |
| 24T864   | KIT, tube-in-tube, 90 pound    |
| 24T865   | KIT, tube-in-tube, 400 pound   |
| 24T866   | KIT, shroud                    |
| 24T867   | KIT, control board replacement |
| 24T897   | KIT, adapter, pump, HP models  |
| 24T898   | KIT, adapter, pump, HF models  |
| 17H538   | KIT, motor control board seal  |

## Accessories

| Part No. | Description   | Related Manual |
|----------|---|----------------|
| 77X522   | Low Level and Dipstick                                  | 332515         |
| 77X511   | Follower Plate, 120# tank / reservoir                   | 312738         |
| 77X512   | Follower Plate, 400# tank / reservoir                   | 312738         |
| 77X514   | Cover, 120# tank / reservoir                            | 312738         |
| 77X515   | Cover, 400# tank / reservoir                            | 312738         |
| 77X500   | Follower Plate - 60# Tank                               | 332517         |
| 77X513   | Mounting Bracket for 35# Bucket                         | 332517         |
| 77X510   | Follower Plate, 35# Bucket                              | 332517         |
| 77X530   | Dip Stick, 90#  | 332515         |
| 77X531   | Dip Stick, 60#  | 332515         |
| 77X540   | Vent Valve, pump mounted                                | 332519         |
| 77X535   | 60 lb Tank  | 332540         |
| 77X536   | 90 lb Tank  | 332540         |
| 16X171   | KIT, outlet manifold                                    | NA             |
| 16V999   | VALVE, pressure relief, 5000 psi (34.47 MPa, 344.7 bar) | NA             |
| 115122   | VALVE, pressure relief, 4000 psi (27.6 MPa, 276 bar)    | NA             |

# Technical Data

| Dyna-Star HP or HF Lubrication Pump            |  |                    |
|--|--|--------------------|
|  | US   | Metric             |
| <b>Maximum Working Pressure</b>                |  |                    |
| HF Models                                      | 3500 psi   | 24.1 MPa, 241 bar  |
| HP Models                                      | 5000 psi   | 34.47 MPa, 344 bar |
| <b>Electrical Requirements</b>                 |  |                    |
| All Models                                     | 24VDC  |                    |
| Wire Terminal AWG Size for Control Board       | 24 to 10 AWG   |                    |
| <b>Input Voltage Range</b>                     |  |                    |
| 24 VDC   | 18 to 32 VDC   |                    |
| <b>ON/OFF Signal Voltage Range and Current</b> |  |                    |
| Voltage Range                                  | 5 to 32 VDC  |                    |
| Drive Resistance                               | 1.1K   |                    |
| <b>Peak Operating Current</b>                  |  |                    |
| 24 VDC   | 35A  |                    |
| <b>Peak Power</b>                              |  |                    |
| 24 VDC   | 720W   |                    |
| <b>Pump Output</b>                             |  |                    |
| HF Models                                      | See Performance Charts, beginning on page 41                       |                    |
| HP Models                                      |  |                    |
| <b>Weight - Pump Only</b>                      |  |                    |
| 35 - 60 lb Tank / Reservoir                    | 50 lb.   | 22.7 kg            |
| 90 - 120 lb Tank / Reservoir                   | 55 lb.   | 25.0 kg            |
| 400 lb Tank / Reservoir                        | 60 lb.   | 27.2 kg            |
| <b>Wetted Parts</b>                            |  |                    |
| Pump Wetted Parts                              | steel, polyurethane, acetal, buna-N, aluminum, polyester elastomer |                    |
| <b>Operating Temperature</b>                   |  |                    |
| HP Models                                      | -40° to 149°F  | -40° to 65°C       |
| HF Models                                      | 14° to 149°F   | -10° to 65°C       |
| Storage Temperature HP and HF Models           | -40° to 149°F  | -40° to 65°C       |
| Humidity Level                                 | 90%  |                    |
| IP Rating                                      | IP69K  |                    |
| Audible Sound Pressure*                        |  |                    |
| 1000 psi (6.89 MPa, 58.95 bar) Models          | 70.7 dB(A)   |                    |
| 2000 psi (13.79 MPa, 137.9 bar) Models         | 71.4 dB(A)   |                    |
| 3000 psi (20.68 MPa, 206.84 bar) Models        | 71.4 dB(A)   |                    |
| 4000 psi (27.58 MPa, 275.79 bar) Models        | 71.2 dB(A)   |                    |
| 5000 psi (34.47 MPa, 374.74 bar) Models        | 70.6 dB(A)   |                    |
| <b>Connector</b>                               |  |                    |
| Front mount connector                          | M23, see page 11   |                    |

\*Sound power was measured per ISO-9614-2.

# Dimensions

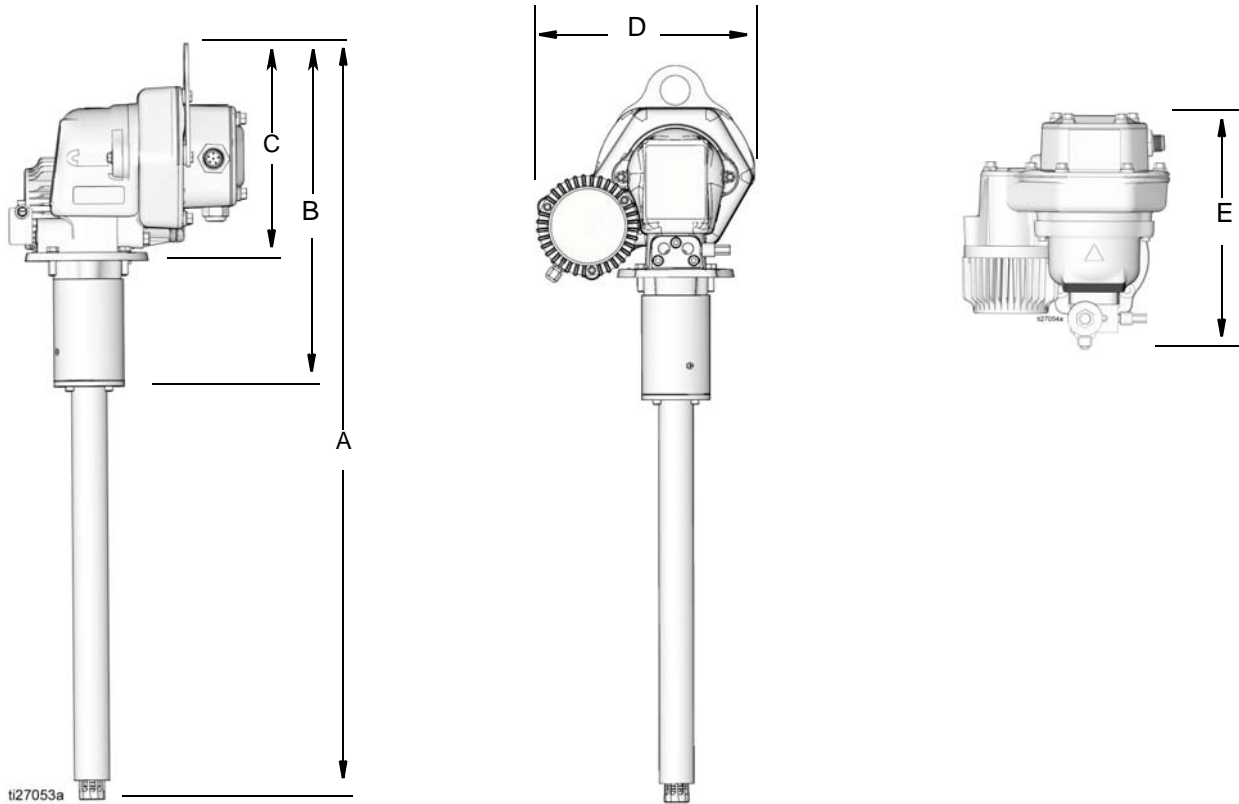

| Ref | 60 Pound Models |             | 90 lb Models |             | 400 lb Models |             |
|-----|-----------------|-------------|--------------|-------------|---------------|-------------|
|     | US (inch)       | Metric (mm) | US (inch)    | Metric (mm) | US (inch)     | Metric (mm) |
| A   | 29              | 737         | 36.5         | 927         | 44.3          | 1125        |
| B   | 16.8            | 427         | 16.8         | 427         | 16.8          | 427         |
| C   | 10.6            | 268         | 10.6         | 268         | 10.6          | 268         |
| D   | 11.0            | 279         | 11.0         | 279         | 11            | 279         |
| E   | 11.1            | 283         | 11.1         | 283         | 11.1          | 283         |



# Performance Charts

**To find the Current (Amp) at a specified Flow Rate (in<sup>3</sup>/min.):**

1. Locate the specified Flow Rate on the vertical axis.
2. Follow the horizontal line to the intersection with the System Operating Pressure.
3. Follow the vertical line down to determine the average current required.

**To find the Flow Rate (in<sup>3</sup>/min.) at a specified current (Amp):**

1. Locate the specified Current on the horizontal axis.
2. Follow the vertical line up to the intersection with the System Operating Pressure.
3. Follow the horizontal line across to determine the Flow Rate.

**Graph 1: HF Model at Ambient Temperature**

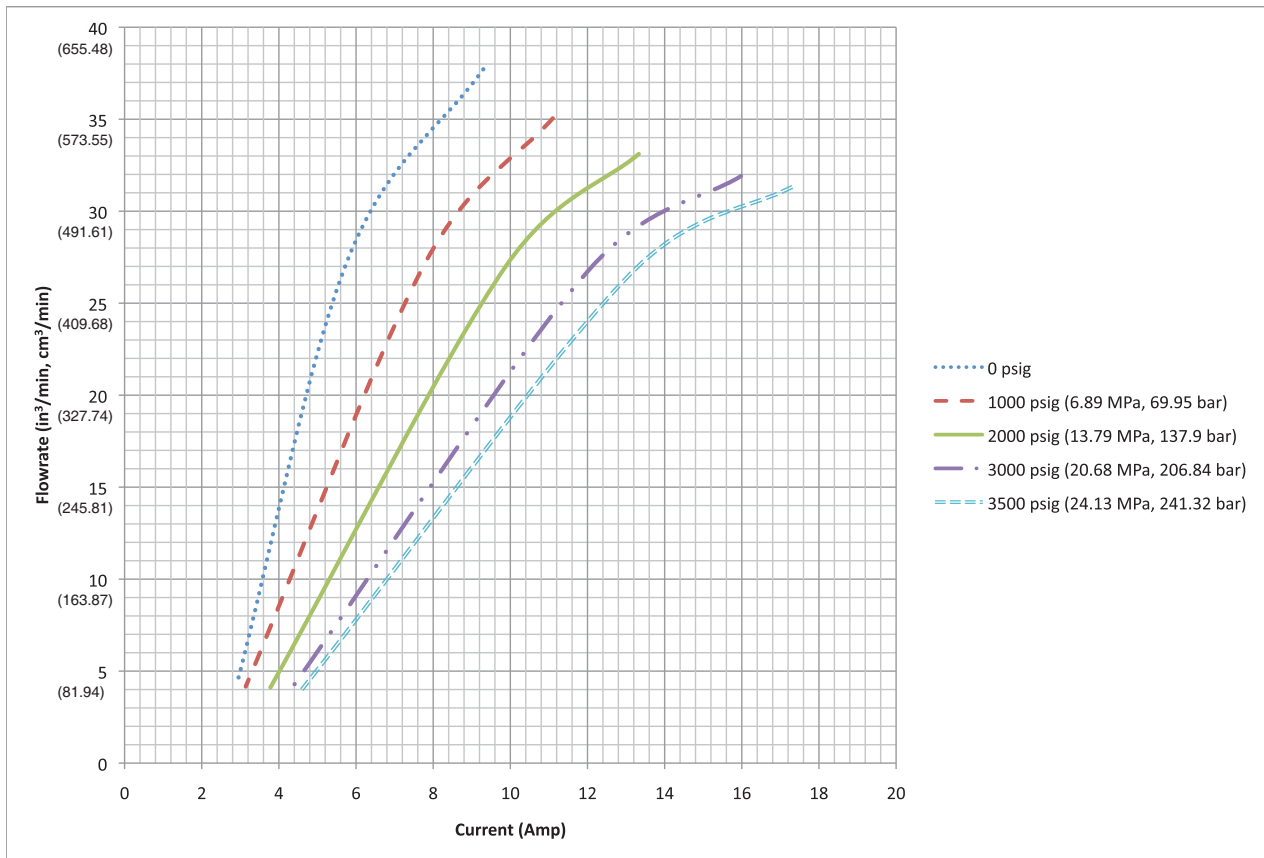

Graph 2: HF Model at 14°F (-10°C)

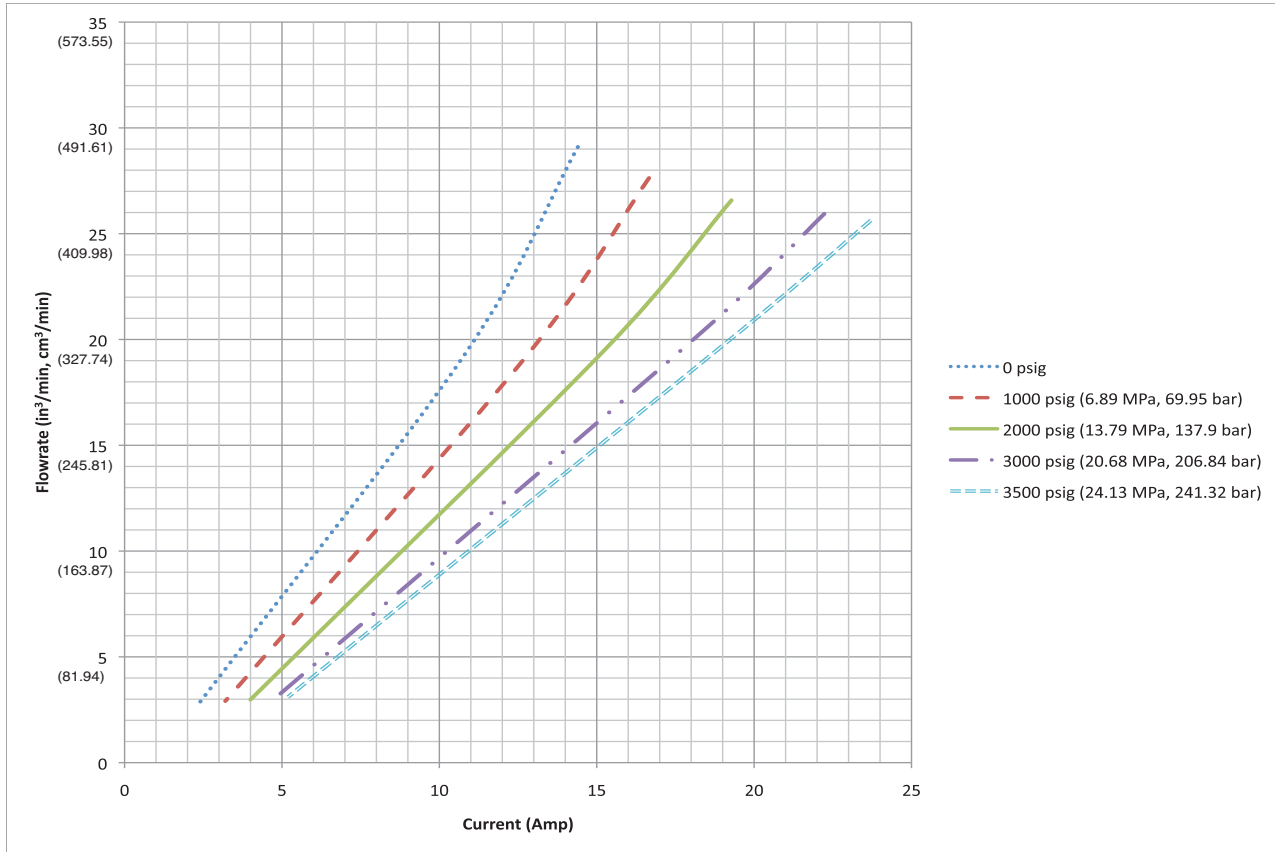

**Graph 3: HP Model at Ambient Temperature**

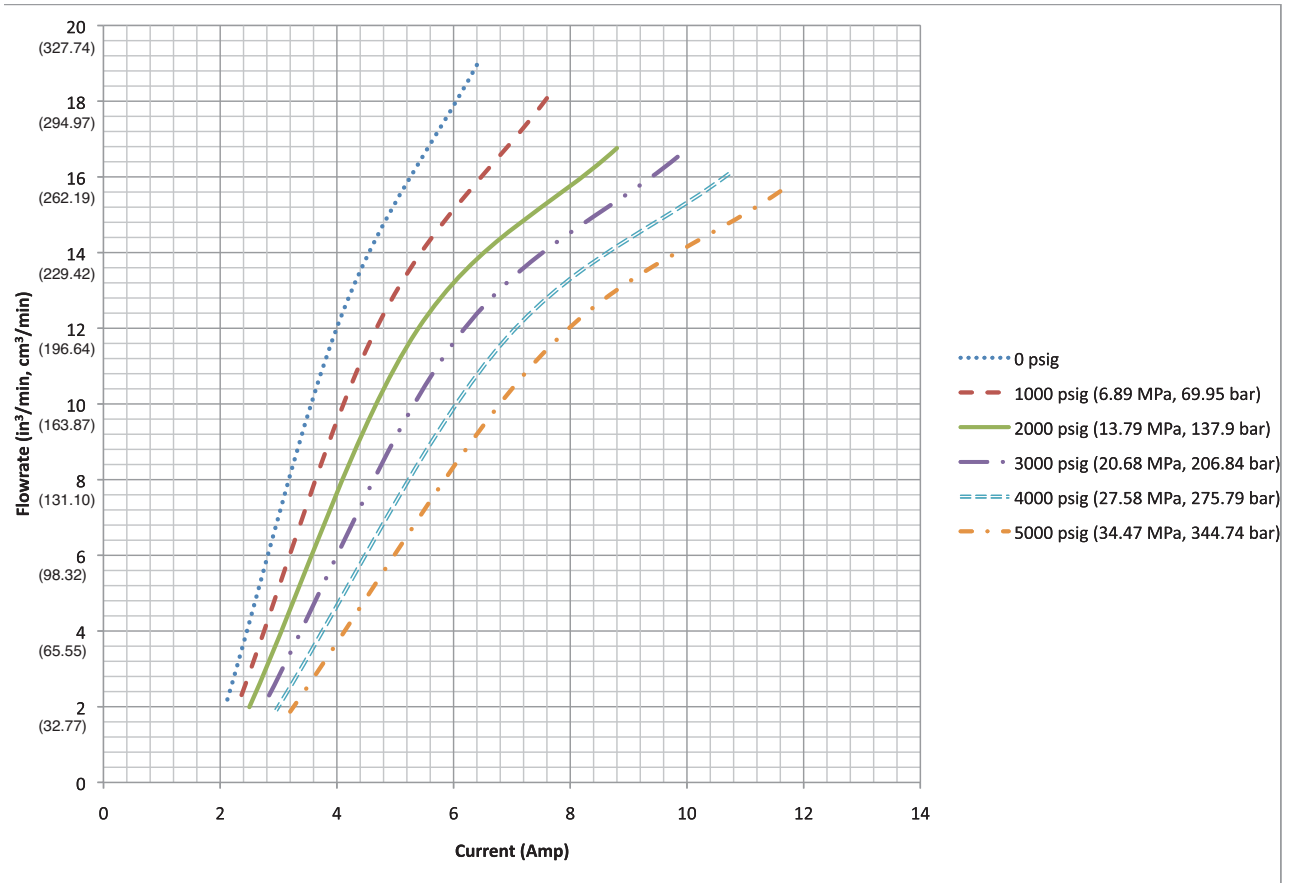

Graph 4: HP Model at -40°F (-40°C)

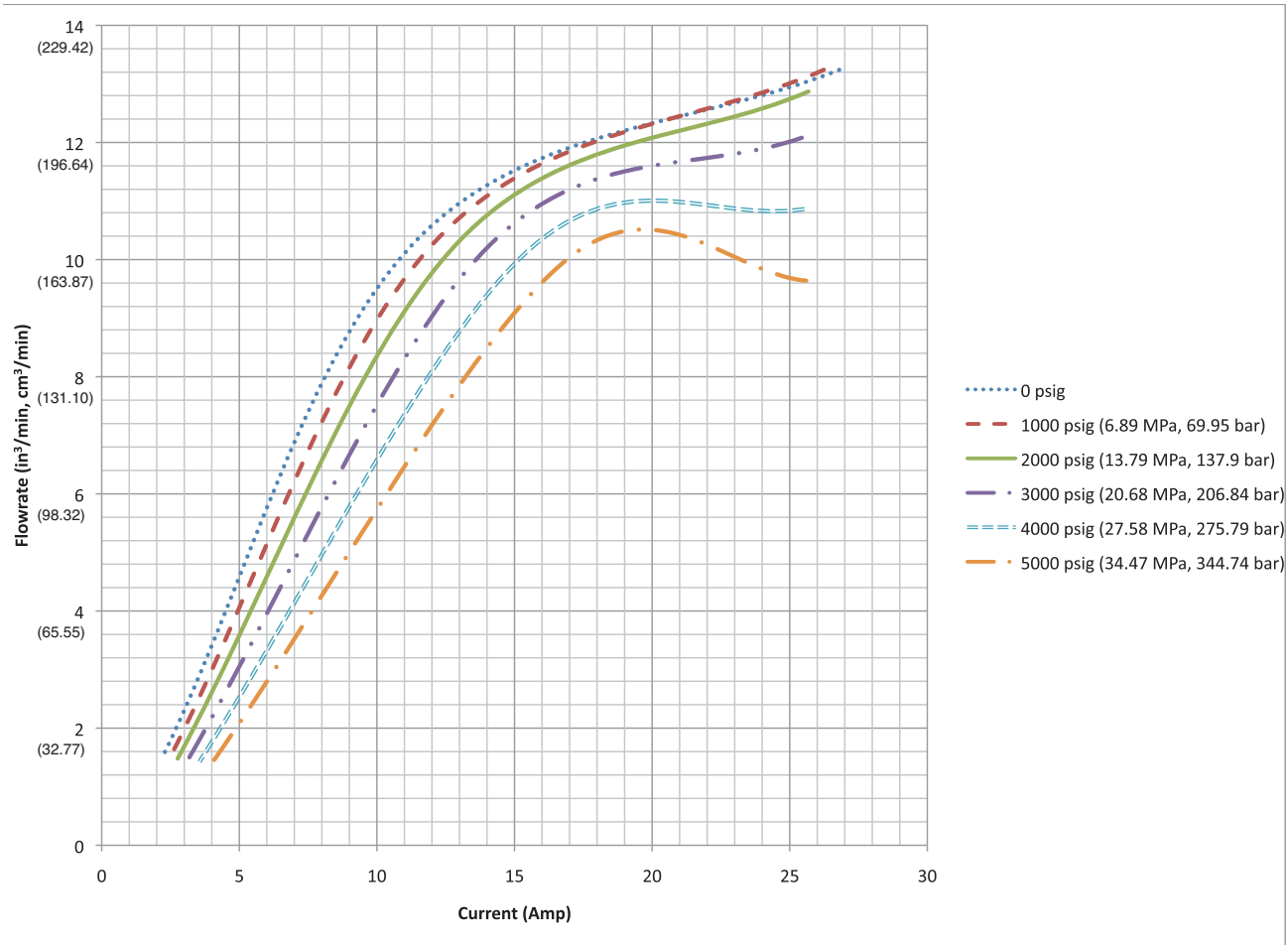



# Graco Standard Warranty

Graco warrants all equipment referenced in this document which is manufactured by Graco and bearing its name to be free from defects in material and workmanship on the date of sale to the original purchaser for use. With the exception of any special, extended, or limited warranty published by Graco, Graco will, for a period of twelve months from the date of sale, repair or replace any part of the equipment determined by Graco to be defective. This warranty applies only when the equipment is installed, operated and maintained in accordance with Graco's written recommendations.

This warranty does not cover, and Graco shall not be liable for general wear and tear, or any malfunction, damage or wear caused by faulty installation, misapplication, abrasion, corrosion, inadequate or improper maintenance, negligence, accident, tampering, or substitution of non-Graco component parts. Nor shall Graco be liable for malfunction, damage or wear caused by the incompatibility of Graco equipment with structures, accessories, equipment or materials not supplied by Graco, or the improper design, manufacture, installation, operation or maintenance of structures, accessories, equipment or materials not supplied by Graco.

This warranty is conditioned upon the prepaid return of the equipment claimed to be defective to an authorized Graco distributor for verification of the claimed defect. If the claimed defect is verified, Graco will repair or replace free of charge any defective parts. The equipment will be returned to the original purchaser transportation prepaid. If inspection of the equipment does not disclose any defect in material or workmanship, repairs will be made at a reasonable charge, which charges may include the costs of parts, labor, and transportation.

**THIS WARRANTY IS EXCLUSIVE, AND IS IN LIEU OF ANY OTHER WARRANTIES, EXPRESS OR IMPLIED, INCLUDING BUT NOT LIMITED TO WARRANTY OF MERCHANTABILITY OR WARRANTY OF FITNESS FOR A PARTICULAR PURPOSE.**

Graco's sole obligation and buyer's sole remedy for any breach of warranty shall be as set forth above. The buyer agrees that no other remedy (including, but not limited to, incidental or consequential damages for lost profits, lost sales, injury to person or property, or any other incidental or consequential loss) shall be available. Any action for breach of warranty must be brought within two (2) years of the date of sale.

**GRACO MAKES NO WARRANTY, AND DISCLAIMS ALL IMPLIED WARRANTIES OF MERCHANTABILITY AND FITNESS FOR A PARTICULAR PURPOSE, IN CONNECTION WITH ACCESSORIES, EQUIPMENT, MATERIALS OR COMPONENTS SOLD BUT NOT MANUFACTURED BY GRACO.** These items sold, but not manufactured by Graco (such as electric motors, switches, hose, etc.), are subject to the warranty, if any, of their manufacturer. Graco will provide purchaser with reasonable assistance in making any claim for breach of these warranties.

In no event will Graco be liable for indirect, incidental, special or consequential damages resulting from Graco supplying equipment hereunder, or the furnishing, performance, or use of any products or other goods sold hereto, whether due to a breach of contract, breach of warranty, the negligence of Graco, or otherwise.

## **FOR GRACO CANADA CUSTOMERS**

The Parties acknowledge that they have required that the present document, as well as all documents, notices and legal proceedings entered into, given or instituted pursuant hereto or relating directly or indirectly hereto, be drawn up in English. Les parties reconnaissent avoir convenu que la rédaction du présente document sera en Anglais, ainsi que tous documents, avis et procédures judiciaires exécutés, donnés ou intentés, à la suite de ou en rapport, directement ou indirectement, avec les procédures concernées.

# Graco Information

For the latest information about Graco products, visit [www.graco.com](http://www.graco.com).

**TO PLACE AN ORDER**, contact your Graco distributor or call to identify the nearest distributor.

**Phone:** 612-623-6928 **or Toll Free:** 1-800-533-9655, **Fax:** 612-378-3590

*All written and visual data contained in this document reflects the latest product information available at the time of publication.  
Graco reserves the right to make changes at any time without notice.*

*For patent information, see [www.graco.com/patents](http://www.graco.com/patents).*

Original instructions. This manual contains English. MM 332514

**Graco Headquarters:** Minneapolis  
**International Offices:** Belgium, China, Japan, Korea

**GRACO INC. AND SUBSIDIARIES • P.O. BOX 1441 • MINNEAPOLIS MN 55440-1441 • USA**

**Copyright 2013, Graco Inc. All Graco manufacturing locations are registered to ISO 9001.**

[www.graco.com](http://www.graco.com)  
September 2015