

## High Pressure Fluid Heater

# VISCON<sup>®</sup> HP

309524S

EN

---

### Used for variable heating of fluids.

*7250 psi (50 MPa, 500 bar) Maximum Working Pressure*



#### Important Safety Instructions

Read all warnings and instructions in this manual.  
Save these instructions.

See page 2 for model numbers, descriptions, and approvals information.

See page 3 for Table of Contents.

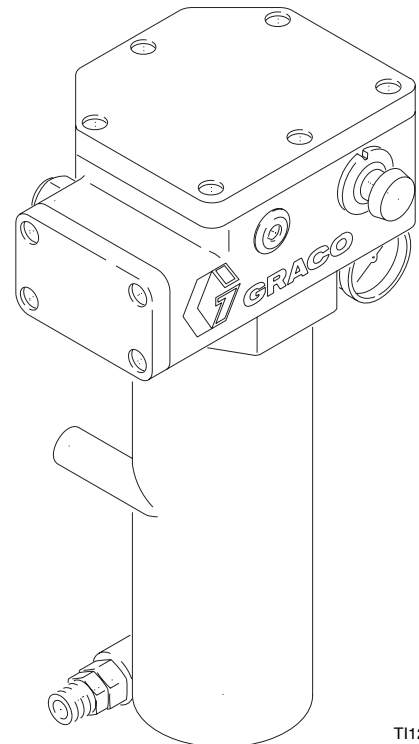





T112338A

**Hazardous Location Heater shown**



# Models

## Hazardous Location Heaters

See Special Conditions for Safe Use in **Warnings**, page 4.

Part No.	Series	VAC (50/60 Hz single phase) / Watts / Amps	Approvals
245848	C	120 / 2300 / 19.2	   <p><b>Intertek</b> 9902471 Certified to CAN/CSA C22.2 No. 88 Conforms to UL 499</p> <p>ATEX Ratings:  II 2 G Ex db IIB T4 Gb ATEX Certificate No. ITS14ATEX181555X</p> <p>IECEX Ratings Ex db IIB T4 Gb IECEX Certificate No. IECEX ETL 14.0046X Ta = -20°C to 60°C</p> <p>For US/CAN: Class 1, Division 1, Groups C, D (T3) Ta = -20°C to 60°C</p> <p>See <b>Technical Data</b>, page 27, for additional information.</p>
245863	C	240 / 4000 / 16.7	
245864	C	480 / 4000 / 8.30	
245862	C	200 / 4000 / 20.0	
246254	C	380 / 4000 / 10.5	

## Non-hazardous Location Heaters

Model No.	Series	VAC (50/60 Hz single phase) / Watts / Amps	Approvals
245867	C	120 / 2300 / 19.2	   <p><b>Intertek</b> 9902471 Certified to CAN/CSA C22.2 No. 88 Conforms to UL 499</p>
245868	C	200 / 4000 / 20.0	
245869	C	240 / 4000 / 16.7	
245870	C	480 / 4000 / 8.30	
246276	C	380 / 4000 / 10.5	
24J787*	C	240 / 4000 / 16.7	





\* Only for use with Graco NVH systems. Must be controlled by GCA.

# Contents

<b>Models</b> .....	<b>2</b>
<b>Warnings</b> .....	<b>4</b>
<b>Installation</b> .....	<b>7</b>
<b>Component Identification</b> .....	<b>8</b>
General Information .....	9
Selecting Tubing .....	9
Mounting Heater .....	10
Fluid Connections & Accessories .....	11
Electrical Connections .....	12
Grounding .....	12
Hazardous Area Cabling and Conduit Requirements	12
<b>Operation</b> .....	<b>14</b>
Pressure Relief Procedure .....	14
Initial Flushing .....	14
Priming System .....	14
Setting Heater Control .....	15
Adjusting for Spraying .....	15
<b>Maintenance</b> .....	<b>16</b>
Flushing .....	16
Draining Heater .....	16
Unclogging Fluid Passages .....	16
<b>Troubleshooting</b> .....	<b>17</b>
<b>Repair</b> .....	<b>18</b>
Primary Thermostat & Probe .....	18
Backup Thermostat .....	18
Thermal Limit Sensor .....	20
Control Knob .....	20
Heater Block .....	20
<b>Parts</b> .....	<b>22</b>
Hazardous Location Heaters .....	22
Non-Hazardous Location Heaters .....	24
<b>Accessories</b> .....	<b>26</b>
<b>Technical Data</b> .....	<b>27</b>
<b>Dimensions</b> .....	<b>28</b>
<b>Graco Standard Warranty</b> .....	<b>30</b>
<b>Graco Information</b> .....	<b>30</b>





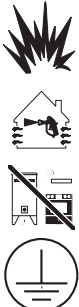

# Warnings

The following warnings are for the setup, use, grounding, maintenance, and repair of this equipment. The exclamation point symbol alerts you to a general warning and the hazard symbols refer to procedure-specific risks. When these symbols appear in the body of this manual or on warning labels, refer back to these Warnings. Product-specific hazard symbols and warnings not covered in this section may appear throughout the body of this manual where applicable.

 <h2 style="margin: 0;">WARNING</h2>	
	<p><b>SPECIAL CONDITIONS FOR SAFE USE</b></p> <ul style="list-style-type: none"> <li>For information on the required dimensions of the flameproof joints contact the holder of this certificate (Graco Inc); Flamepath joints are not intended to be repaired.</li> <li>Special fasteners for securing equipment covers shall have a minimum yield strength of 1,100 MPa and be corrosion resistant and sized M8 x 1.25 x 30.</li> </ul>
	<p><b>ELECTRIC SHOCK HAZARD</b></p> <p>This equipment must be grounded. Improper grounding, setup, or usage of the system can cause electric shock.</p> <ul style="list-style-type: none"> <li>Turn off and disconnect power at main switch before disconnecting any cables and before servicing or installing equipment.</li> <li>Connect only to grounded power source.</li> <li>All electrical wiring must be done by a qualified electrician and comply with all local codes and regulations.</li> </ul>
	<p><b>BURN HAZARD</b></p> <p>Equipment surfaces and fluid that is heated can become very hot during operation. To avoid severe burns:</p> <ul style="list-style-type: none"> <li>Do not touch hot fluid or equipment.</li> </ul>
	<p><b>FIRE AND EXPLOSION HAZARD</b></p> <p>Flammable fumes, such as solvent and paint fumes, in <b>work area</b> can ignite or explode. To help prevent fire and explosion:</p> <ul style="list-style-type: none"> <li>Use equipment only in well ventilated area.</li> <li>Eliminate all ignition sources; such as pilot lights, cigarettes, portable electric lamps, and plastic drop cloths (potential static arc).</li> <li>Keep work area free of debris, including solvent, rags and gasoline.</li> <li>Do not plug or unplug power cords, or turn power or light switches on or off when flammable fumes are present.</li> <li>Ground all equipment in the work area. See <b>Grounding</b> instructions.</li> <li>Use only grounded hoses.</li> <li>Hold gun firmly to side of grounded pail when triggering into pail. Do not use pail liners unless they are antistatic or conductive.</li> <li><b>Stop operation immediately</b> if static sparking occurs or you feel a shock. Do not use equipment until you identify and correct the problem.</li> <li>Keep a working fire extinguisher in the work area.</li> <li>Never operate with covers removed. Do not open when energized.</li> <li>Install conduit within 18 in (457 mm).</li> <li>Do not install if operating temperature exceeds ignition temperature of hazardous atmosphere.</li> </ul>



# WARNING

  	<p><b>SKIN INJECTION HAZARD</b></p> <p>High-pressure fluid from gun, hose leaks, or ruptured components will pierce skin. This may look like just a cut, but it is a serious injury that can result in amputation. <b>Get immediate surgical treatment.</b></p> <ul style="list-style-type: none"> <li>• Do not spray without tip guard and trigger guard installed.</li> <li>• Engage trigger lock when not spraying.</li> <li>• Do not point gun at anyone or at any part of the body.</li> <li>• Do not put your hand over the spray tip.</li> <li>• Do not stop or deflect leaks with your hand, body, glove, or rag.</li> <li>• Follow the <b>Pressure Relief Procedure</b> when you stop spraying and before cleaning, checking, or servicing equipment.</li> <li>• Tighten all fluid connections before operating the equipment.</li> <li>• Check hoses and couplings daily. Replace worn or damaged parts immediately.</li> </ul>
	<p><b>TOXIC FLUID OR FUMES HAZARD</b></p> <p>Toxic fluids or fumes can cause serious injury or death if splashed in the eyes or on skin, inhaled, or swallowed.</p> <ul style="list-style-type: none"> <li>• Read MSDSs to know the specific hazards of the fluids you are using.</li> <li>• Store hazardous fluid in approved containers, and dispose of it according to applicable guidelines.</li> </ul>
	<p><b>PERSONAL PROTECTIVE EQUIPMENT</b></p> <p>Wear appropriate protective equipment when in the work area to help prevent serious injury, including eye injury, hearing loss, inhalation of toxic fumes, and burns. This protective equipment includes but is not limited to:</p> <ul style="list-style-type: none"> <li>• Protective eyewear, and hearing protection.</li> <li>• Respirators, protective clothing, and gloves as recommended by the fluid and solvent manufacturer</li> </ul>
 	<p><b>EQUIPMENT MISUSE HAZARD</b></p> <p>Misuse can cause death or serious injury.</p> <ul style="list-style-type: none"> <li>• Do not operate the unit when fatigued or under the influence of drugs or alcohol.</li> <li>• Do not exceed the maximum working pressure or temperature rating of the lowest rated system component. See <b>Technical Data</b> in all equipment manuals.</li> <li>• Use fluids and solvents that are compatible with equipment wetted parts. See Technical Data in all equipment manuals. Read fluid and solvent manufacturer's warnings. For complete information about your material, request MSDS from distributor or retailer.</li> <li>• Do not leave the work area while equipment is energized or under pressure.</li> <li>• Turn off all equipment and follow the <b>Pressure Relief Procedure</b> when equipment is not in use.</li> <li>• Check equipment daily. Repair or replace worn or damaged parts immediately with genuine manufacturer's replacement parts only.</li> <li>• Do not alter or modify equipment. Alterations or modifications may void agency approvals and create safety hazards.</li> <li>• Make sure all equipment is rated and approved for the environment in which you are using it.</li> <li>• Use equipment only for its intended purpose. Call your distributor for information.</li> <li>• Route hoses and cables away from traffic areas, sharp edges, moving parts, and hot surfaces.</li> <li>• Do not kink or over bend hoses or use hoses to pull equipment.</li> <li>• Keep children and animals away from work area.</li> <li>• Comply with all applicable safety regulations.</li> </ul>

 **WARNING**



**PRESSURIZED ALUMINUM PARTS HAZARD**

Use of fluids that are incompatible with aluminum in pressurized equipment can cause serious chemical reaction and equipment rupture. Failure to follow this warning can result in death, serious injury, or property damage.

- Do not use 1,1,1-trichloroethane, methylene chloride, other halogenated hydrocarbon solvents or fluids containing such solvents.
- Many other fluids may contain chemicals that can react with aluminum. Contact your material supplier for compatibility.



**THERMAL EXPANSION HAZARD**

Fluids subjected to heat in confined spaces, including hoses, can create a rapid rise in pressure due to the thermal expansion. Over-pressurization can result in equipment rupture and serious injury.

- Open a valve to relieve the fluid expansion during heating.
- Replace hoses proactively at regular intervals based on your operating conditions.



# Installation

## Typical Installation Drawing

The typical installation drawing is only a guide. Your Graco distributor can assist in designing your system.

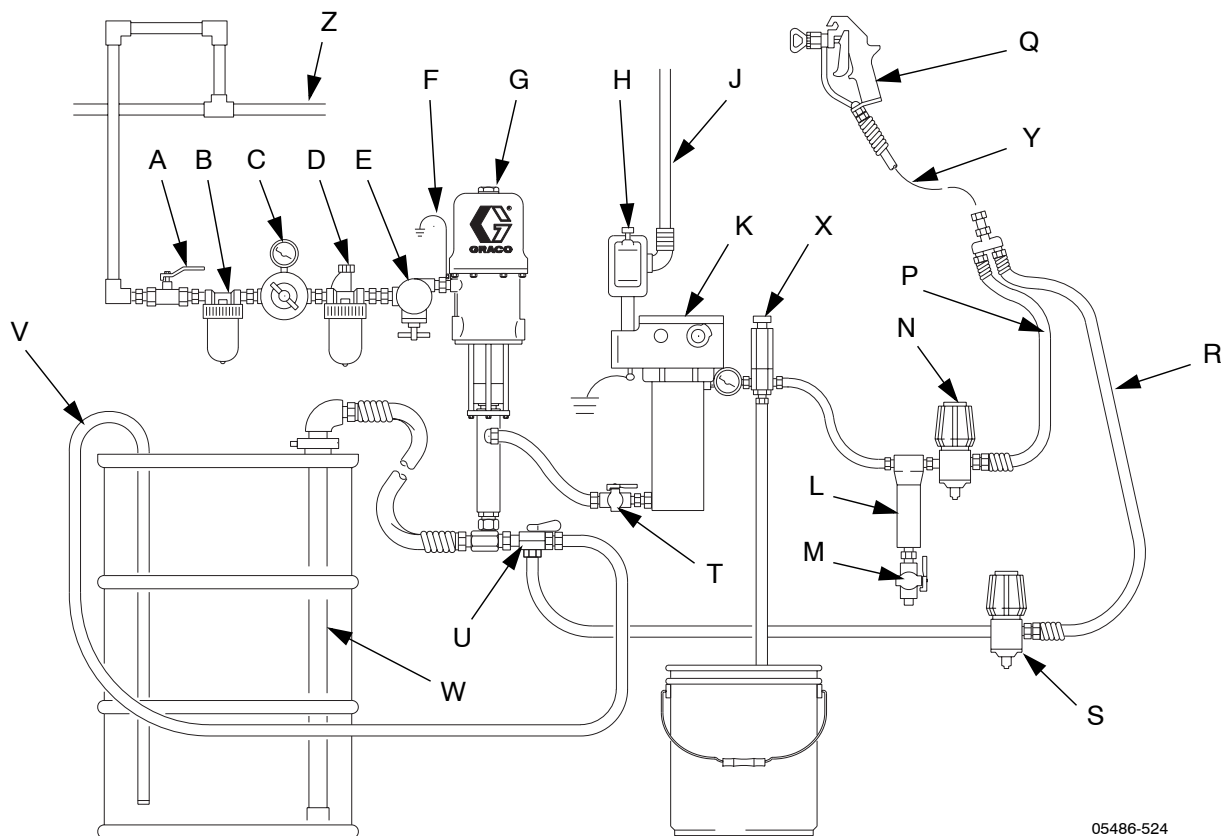

05486-524

**Key:**

- |                                |                            |                         |
|--------------------------------|----------------------------|-------------------------|
| A Bleed-type Master Air Valve  | J Power Cable              | S Back Pressure Valve   |
| B Air Filter                   | K Heater                   | T Fluid Shutoff Valve   |
| C Air Regulator and Gauge      | L Fluid Filter             | U Director Valve        |
| D Air Line Lubricator          | M Drain Valve              | V Drain Back Tube       |
| E Pump Runaway Valve           | N Fluid Pressure Regulator | W Suction Tube          |
| F Ground Wire                  | P Fluid Supply Line        | X Pressure Relief Valve |
| G Pump                         | Q Spray Gun                | Y Whip End Hose         |
| H Explosion Proof Power Switch | R Fluid Return Line        | Z Air Supply Line       |

**FIG. 1: Typical Installation – Heated Circulating System**

# Component Identification

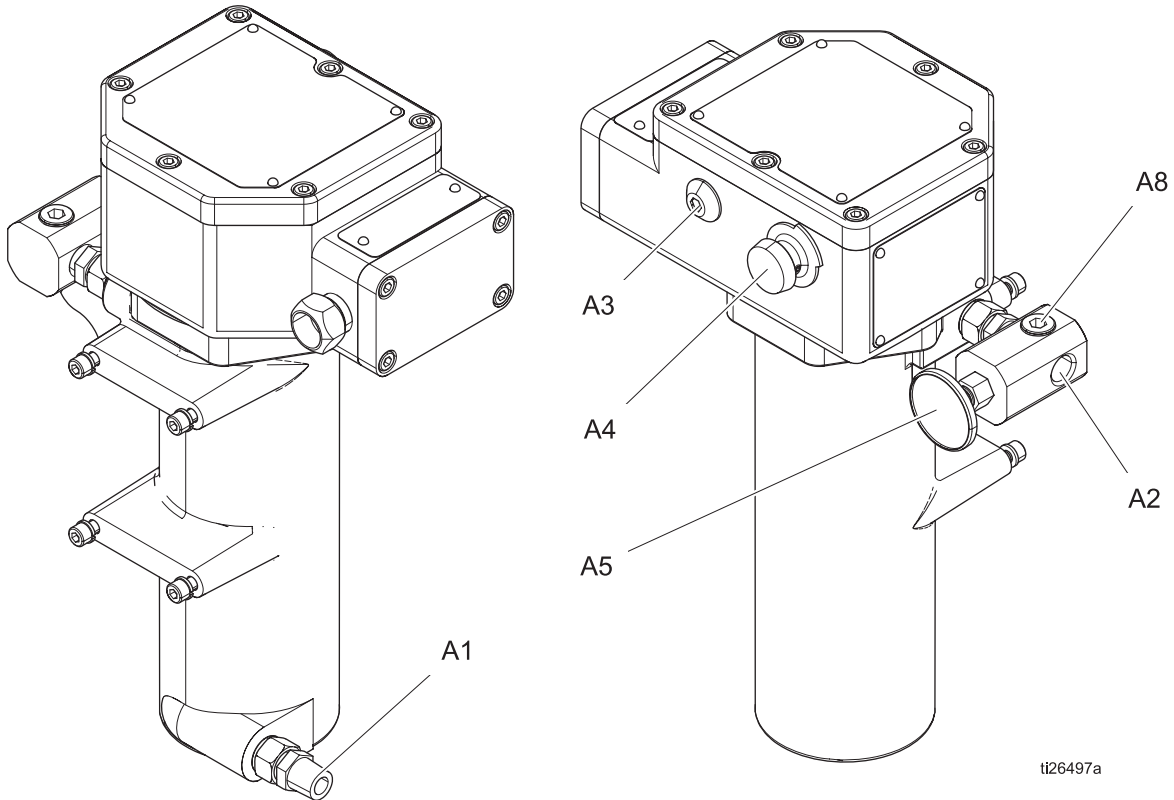



ti26497a

**Key:**

- A1 Fluid Inlet
- A2 Fluid Outlet
- A3 Heater ON Indicator Light
- A4 Temperature Control Knob
- A5 Temperature Gauge
- A8 Optional Outlet Ports (one on outlet manifold and one on opposite side of heater)



## General Information

						
---	---	---	--	--	--	--

- Select system components that meet temperature and pressure ratings listed in **Technical Data**, page 27. The heater's normal output range is adjustable from 84-220°F (29-104°C).
- To prevent fire and explosion, locate heater away from all flammable materials and where operators will not come in contact with hot metal surfaces.
- To avoid burns, insulate and/or label lines and components exiting heater that may become hot.

### NOTICE

The inlet fluid temperature cannot exceed 275°F (135°C). This will cause the heater to exceed its rated temperature code.

## Selecting Tubing

Fluid loses some heat through the tubing or hose between the heater and spray gun. Locate heater close to the spray area to minimize heat loss through plumbing.

The chart in FIG. 2 shows a heat loss curve for 3 common types of tubing.

### Chart Notes:

- Higher flow rates have less heat loss.
- Foam-insulated steel tubing and high pressure airless paint hose retain heat best. Insulated tubing and hose are more expensive, but higher costs are commonly offset by lower operating costs.
- Locate heater close to spray area to minimize heat loss through plumbing.

Heat Loss Curve - 70° F (21° C) ambient

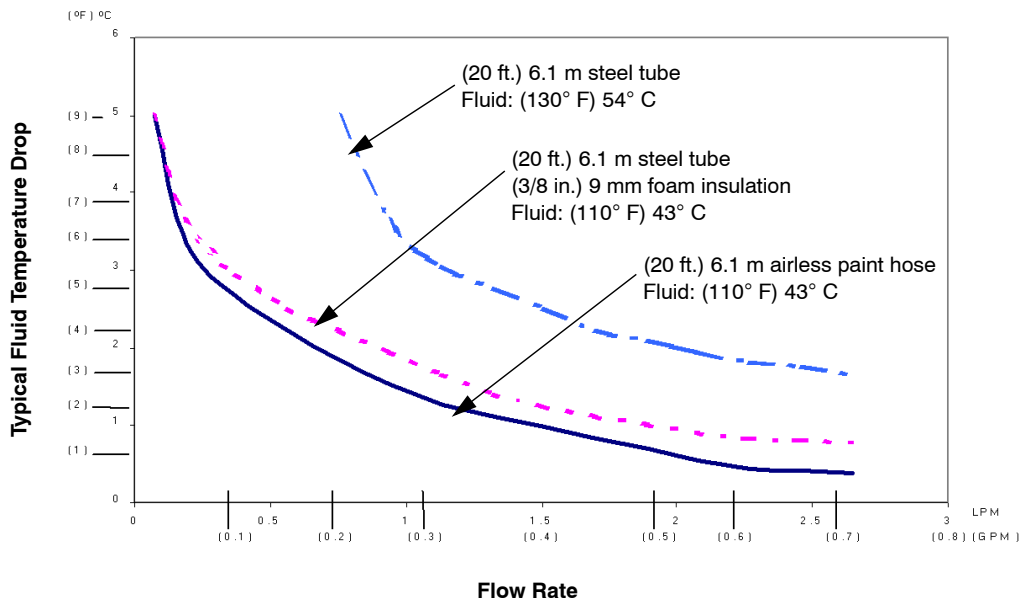

FIG. 2: Typical Temperature Drop

## Mounting Heater

**NOTE:** Heater controls must be easily accessible.

**NOTE:** The mounting surface must be able to support the weight of the heater and fluid, and any stress caused during operation.

### Wall Mounting

**NOTE:** Need wall bracket 192585 or 183982. See **Accessories**, page 26. Use wall bracket as a template to mark bolt holes.

#### Bracket 192585

(FIG. 3)

**NOTE:** Bracket depth provides required solid object clearance to comply with European flame proof standards.

1. Use M8 bolts of appropriate length and lockwasher (CC), not supplied, to mount bracket.
2. Install two screws (6) and washers (5) into top 2 heater mounting posts (BB) until they are about 1/8 in. (3 mm) from fully installed.
3. Lift heater and slide two screw heads into bracket slots. Install remaining 2 screws and tighten all 4.

#### Bracket 183982

(FIG. 4)

1. Mount bracket (MM) to heater with screws (6) and lockwashers (5) supplied.
2. Use M8 bolts of the appropriate length and lockwasher (NN), not supplied, to secure the bracket to the wall.

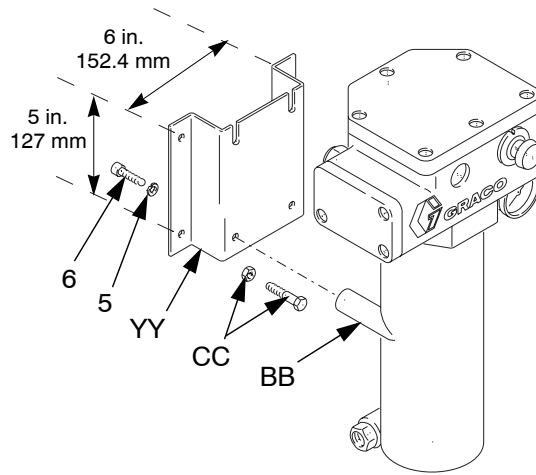

05442

**FIG. 3: Bracket 192585**

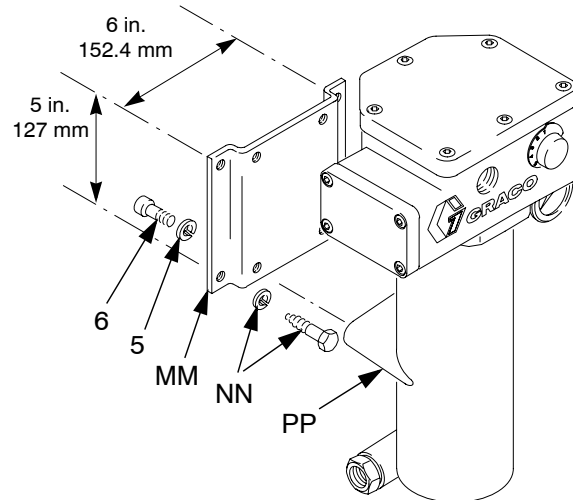

8631A

**FIG. 4: Bracket 183982**

## Cart Mounting (FIG. 5)

**NOTE:** You need to have 2 each of cart mounting bar 183485 and clamp 183484. See **Accessories**, page 26, to order.

1. Place clamps (AA) around the cart vertical post (DD) and secure to the heater mounting bars (ZZ) with M8 x 1.25 x 30 mm bolts (6) and lockwasher (5).
2. Observe temperature ratings for the power cable to the terminal junction. Cable H07RN **does not** meet the required 221°F (105°C). An intermediate Type “e” junction may be required. Also see FIG. 7.

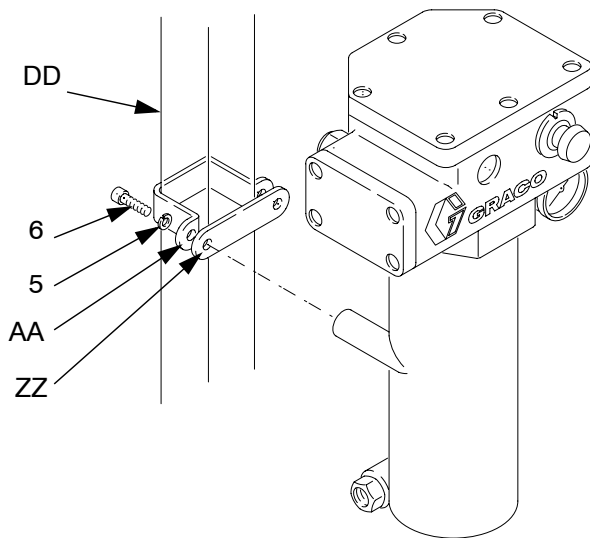

05543-524

**FIG. 5: Cart Mounting**

## Fluid Connections & Accessories

(FIG. 6)

1. Install a fluid shutoff valve (T) in the heater's 1/2-14 npt(m) fluid inlet; do not overtighten. Connect the fluid line to the valve.

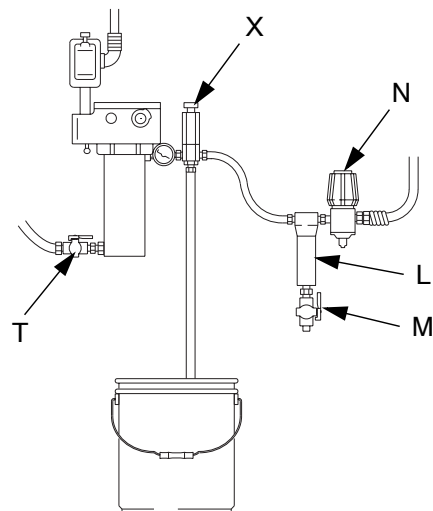

05545-524

**FIG. 6: Fluid Connections & Accessories**

<p>To prevent serious injury caused by component or equipment rupture:</p> <ul style="list-style-type: none"> <li>• Never install a shutoff device between the heater and gun as this will trap the heated fluid and not allow for expansion.</li> <li>• Never use a fluid regulator as a shutoff device if it is installed between the heater and gun</li> <li>• Provide a means for adequately handling fluid expansion caused by heat.</li> </ul>					

2. Provide a means for adequately handling fluid expansion caused by heat. Options include:
  - Use flexible hoses between heater and gun.
  - Install a properly sized accumulator downstream from the heater.
  - Install a pressure relief valve (X) pre-set to relieve pressure when it exceeds the system maximum working pressure.

Never install a shutoff device between the heater and gun as this will trap the heated fluid and not allow for expansion. If a fluid regulator is installed between the heater and gun, never use it as a shutoff device.

3. Install a fluid filter (L), drain valve (M), and fluid pressure regulator (N) near the heater's 1/2-14 npt(f) fluid outlet. Then connect the fluid line.

## Electrical Connections

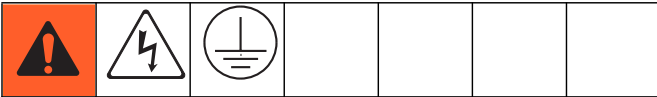

Heater installation must be in compliance with all applicable local codes and regulations. This equipment must be grounded. Improper grounding, setup, or usage of the system can cause electric shock. All electrical wiring must be done by a qualified electrician and comply with all local codes and regulations.

### NOTICE

To help prevent damage, avoid spilling liquids onto electrical components and never operate with the cover removed or screws missing.

## Requirements For All Installations

- The power supply must not exceed heater voltage and amperage. See **Models**, page 2.
- Conductors used for supply connection must be suitable for at least 221°F (105°C). An intermediate Type “e” junction may be required.
- Branch circuit breaker over-current protection must be used. The recommended branch circuit breaker size is 30 amps.
- Connections are made through the strain relief cord grip (87). It will accept cords with an outside diameter of 0.51-0.71 in. (13-18 mm).
- Make your ground connection to the green ground lug inside the control head.
- For hazardous models only: Make your power connections through the 3/4 in. npt port to the two post bushings in the control head. Refer to the applicable schematic on page 19.

## Grounding

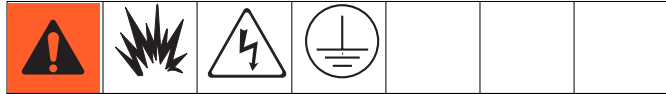

The equipment must be grounded to reduce the risk of static sparking and electric shock. Electric or static sparking can cause fumes to ignite or explode. Improper grounding can cause electric shock. Grounding provides an escape wire for the electric current.

Wire the heater to a properly grounded power supply through the electrical connections and grounding screw (8). In a mobile installation, also ground the truck or trailer to a true earth ground.

## Hazardous Area Cabling and Conduit Requirements

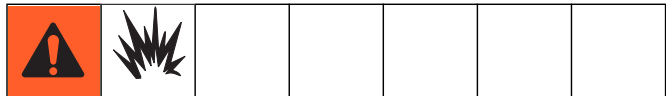

### Explosion Proof

All electrical wiring in the hazardous area must be encased in Class I, Division I, Groups C1 and D approved explosion-proof conduit. Follow all National, State, and Local electric codes.

A conduit seal (D) is required within 18 in. (457 mm) of the heater for the US and Canada. All cables must be rated at 221°F (105°C).

### Flame Proof (ATEX)

Use appropriate conduit, connectors, and cable glands rated for ATEX II 2 G. Follow all National, State, and Local electric codes. All cable glands and cables must be rated at 221°F (105°C).

### Wall Mounted Wiring

Mount a 2-pole, explosion-proof electric switch (H) near the heater. See FIG. 7. The switch must meet the electrical codes for your location. Also use the correct cable and plug.

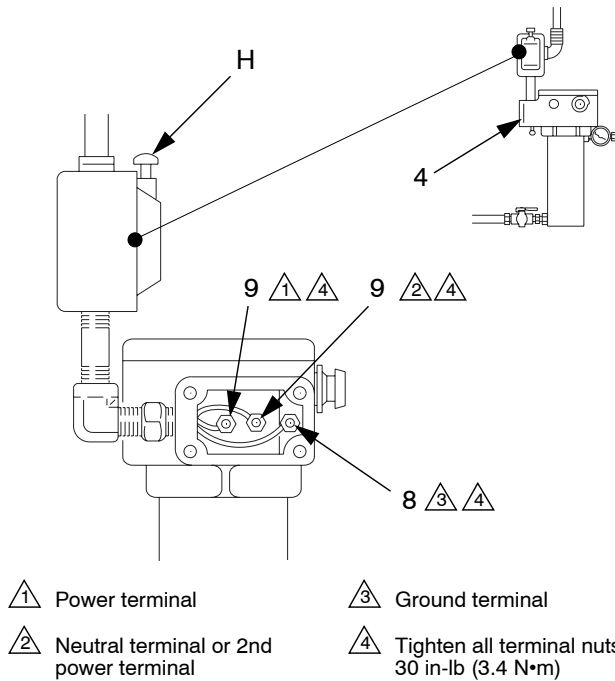
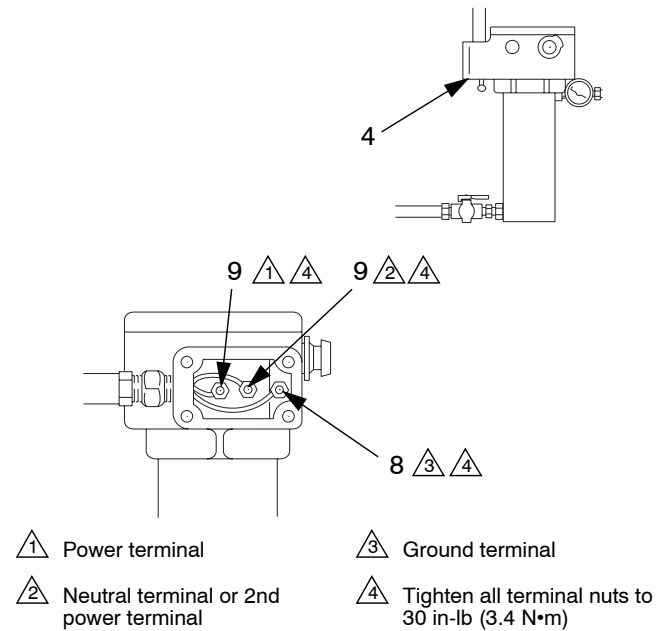

**FIG. 7: Wall Mounted Wiring**

05546-524

### Cart Mounted Wiring

Connect a plug that meets the electrical codes for your location. See FIG. 8.



**FIG. 8: Cart Mounted Wiring**

05547-524

# Operation

## Pressure Relief Procedure



Follow the Pressure Relief Procedure whenever you see this symbol.



This equipment stays pressurized until pressure is manually relieved. To help prevent serious injury from pressurized fluid, such as skin injection, and splashing fluid, follow the Pressure Relief Procedure when you stop spraying and before cleaning, checking, or servicing the equipment.

Follow **Pressure Relief Procedure** when you stop spraying, and before cleaning, checking, or servicing equipment.

1. Engage the gun safety lock.
2. Shut off main power to the heater.
3. Circulate fluid for at least 10 minutes to cool the heated fluid and heater.
4. Shut off all air and fluid supplies.
5. Disengage the safety lock.
6. Hold a metal part of the gun firmly to a grounded metal pail, and trigger the gun to relieve pressure.
7. Engage the safety lock.
8. Have a container ready to catch the fluid, then open the fluid drain valve.

## Initial Flushing

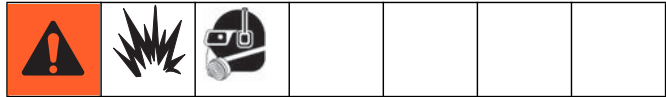

To avoid fire and explosion:

- Flush equipment only in a well-ventilated area
- Ensure main power is off and heater is cool before flushing
- Do not turn on heater until fluid lines are clear of solvent

The heater was tested with lightweight oil, which needs to be flushed out before using the equipment. Ensure main power is off and heater is cool before flushing. Use a compatible solvent, and follow flushing instructions in your fluid supply and spray gun manual.

## Priming System

(Refer to FIG. 1, page 7)

<b>NOTICE</b>
To prevent damage, do not turn on heater until system is fully primed.

1. Do not turn on the heater yet.
2. If using an airless spray gun, do not install a spray tip yet.
3. Start the pump according to the instructions supplied with it.
4. Turn the system director valve (U) to circulate, and circulate fluid for several minutes.
5. Open the spray gun (Q) at the last outlet to prime the line. Repeat for all gun stations.
6. Engage the gun safety latch.
7. Shut off the air supply to the pump.
8. Follow **Pressure Relief Procedure**.
9. Install the gun spray tip.

## Setting Heater Control

(Refer to FIG. 9)

1. Set the heater control knob (33) to a trial setpoint of 4 or 5.
2. Start the pump and circulate fluid through the system at very low pressure, about 10-12 oz/min (0.30-0.35 liter/min).
3. After 10 minutes, read the temperature on the thermometer (2). If it does not match the desired temperature, adjust the setpoint.

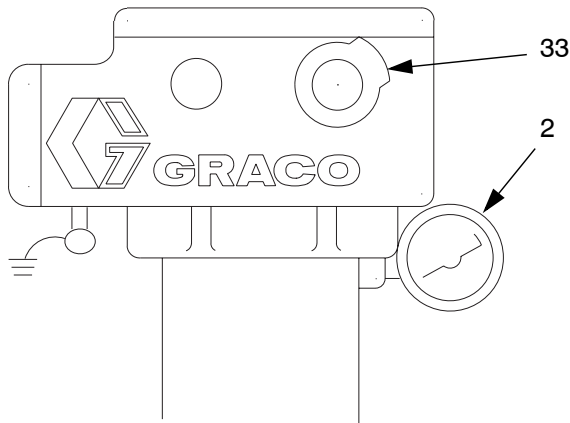

05549-524

**FIG. 9: Setting Heater Control**

## Adjusting for Spraying

### NOTICE

Operating the heater at its highest setting of over 180°F (82°C) for long periods of time decreases the heater life and can cause fluid to dry out which can cause heater clogging and a poor spray pattern.

1. Adjust pump pressure and heater setpoint to the lowest settings needed for good fluid atomization.
2. Set all system back pressure valves (S - FIG. 1) to maintain even fluid pressure at all gun stations.

# Maintenance

## Flushing



To avoid fire and explosion:

- Flush equipment only in a well-ventilated area
- Ensure main power is off and heater is cool before flushing
- Do not turn on heater until fluid lines are clear of solvent

Clogged fluid passages are difficult to clean and reduce heating efficiency, flow rate, and pressure. Flush frequently, including whenever system is not in use.

1. Follow **Pressure Relief Procedure**, page 14.
2. Ensure main power is off and heater is cool before flushing. Use a compatible solvent, and follow flushing instructions in your fluid supply and spray gun manual. **Do not turn on heater until fluid lines are clear of solvent.**

## Draining Heater

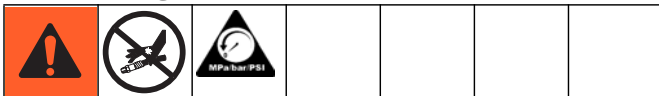

(FIG. 10)

1. Follow **Pressure Relief Procedure**, page 14.
2. Remove heater inlet and outlet fittings. Have a container ready to catch the fluid.

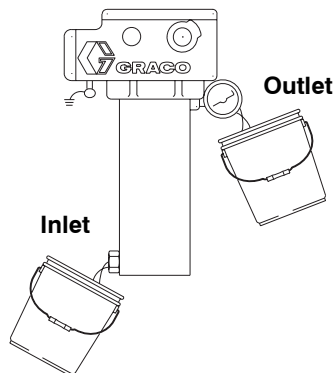

FIG. 10: Draining Heater

05550-524

## Unclogging Fluid Passages

(FIG. 11)

1. Drain the heater.
2. Remove the heater block (3) from the heater housing. See **Heater Block**, page 20.
3. Pour a high strength, **compatible** solvent into the heater tube to soften the clog.
4. Flush out the clog.
5. Clean all passages thoroughly before reassembling.

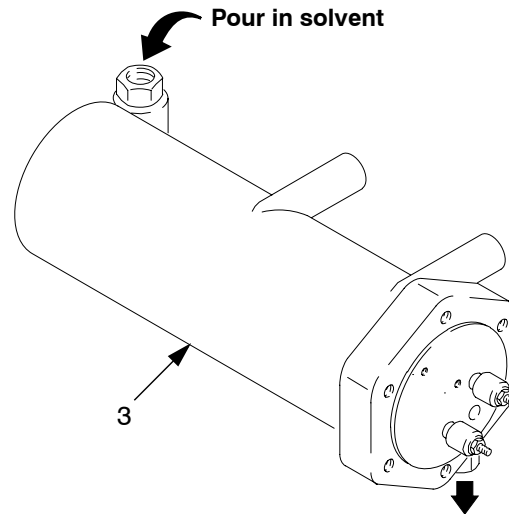

05551-524

FIG. 11: Unclogging Fluid Passages



# Troubleshooting

Problem	Cause	Solution
Heater will not heat.	No current.	Check circuit and fuses.  Check continuity of primary thermostat (24), backup thermostat (10), and thermal limit sensor (15).  Check continuity of thermostat (10) and heater block (3) terminals - Page 18.
	Burned out heater block (3).	Replace block - Page 20.
	Blown heat limiter (15).	Check continuity of primary thermostat (24) and backup thermostat (10). Replace thermostats if necessary when replacing thermal limit sensor (15) - Pages 18-20.
Temperature too low.	Fluid requires more warm-up time.	Increase warm-up time.
	Wrong temperature setting.	Adjust setting - Page 15.
	Flow rate too high.	Reduce flow rate or use 2 heaters.
	Clogged fluid passages.	Flush regularly - Page 16.
Temperature too high.	Wrong temperature setting.	Adjust setting - Page 15.
	Failed primary thermostat (24).	Replace - Page 18.
High fluctuating temperatures, about 220-250°F (104-120°C) at 0.1 GPM.	Primary thermostat (24) contacts sticking.	Replace thermostats (24, 10) - Page 18. Note that backup thermostat (10) keeps heater functioning for only a short time.
Too much pressure drop or fluid will not flow.	Flow rate too high.	Reduce flow rate or use 2 heaters.
	Clogged fluid passages.	Flush regularly - Page 16.
Heater fittings leak.	Loose or damaged fittings.	Tighten fittings or replace heater block - Page 20.

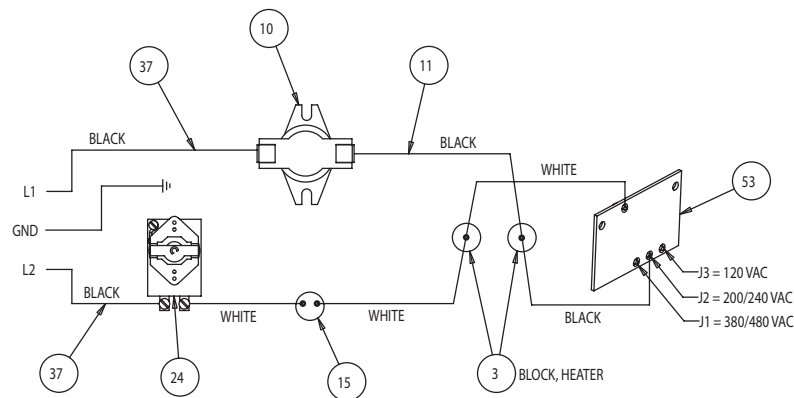

**FIG. 12: Electrical Schematic**

# Repair

					
To avoid burns, electric shock, and skin injection, make sure the main power is OFF, heater is cool, and pressure is relieved before repairing.					

**Hazardous Location Heaters: See FIG. 13 & 15**

**Non-hazardous Location Heaters: See FIG. 14 & 16**

## Primary Thermostat & Probe

1. Follow **Pressure Relief Procedure**, page 14.
2. Remove housing cover (18).
3. *Hazardous Location Heater only:* Loosen nut (27).  
*Non-hazardous Location Heater only:* Loosen screws (25).
4. Loosen setscrew (26) in switch shaft (28).
5. Remove screw (16) and bracket (19) holding probe (EE).
6. Remove wires from the primary thermostat terminals (FF).
7. Pull thermostat probe (EE) out of heater block (3). Remove thermostat (24) from housing (1).
8. *Hazardous Location Heater only:* Remove screws (25).  
*Non-hazardous Location Heater only:* Remove screw standoff (35) with washer (27).
9. Remove bracket from thermostat (24) and secure to new thermostat.

### NOTICE

To avoid damaging capillary tube (GG), which can cause heater malfunction, do not kink or nick the tube.

To avoid shorting out the heater, do not allow capillary tube to contact the block terminal (3A). Follow step 10, below.

10. Liberally apply thermal lubricant (part no. 110009) to probe (EE) of new thermostat (24). Loop capillary tube (GG) several times and wrap the loops with tie strap (42-not shown). Insert probe in the heater block (3).
11. Continue reassembling in reverse order of disassembly. See **Reassembly Notes**, below.

## Backup Thermostat

1. Follow **Pressure Relief Procedure**, page 14.
2. Remove housing cover (18).
3. Remove screws (HH) on backup thermostat (10) tabs, and remove the wires – one from heater block (3A) and one from line in (9B).
4. Remove the two screws (16), then remove the thermostat (10).
5. Liberally apply thermal lubricant (part no. 110009) to the bottom of the thermostat (10) and reinstall it in reverse order of disassembly.

## Reassembly Notes

- Refer to FIG. 13 or 14 for wiring connections.
- *Non-hazardous Location Heater only:* Make sure gasket (47) is installed and aligned with electrical housing screw holes.
- Secure cover (18) with lockwashers (5) and screws (6 or 52); torque screws to 89 in-lb (10 N•m).

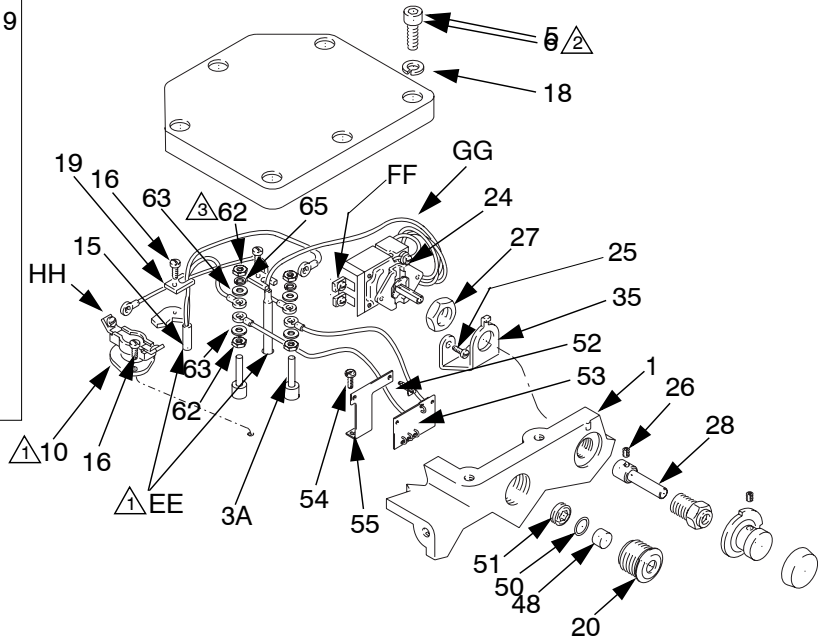
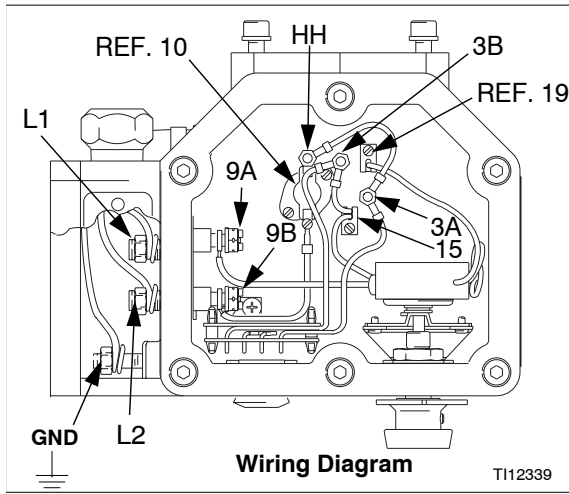

- ① Apply thermal lubricant
- ② Torque to 89 in-lb (10 N•m)
- ③ Torque nuts (62) to 13-14 in-lb (1.4-1.5 N•m)

T112335D

**FIG. 13: Thermostat Repair – Hazardous Location Heaters**

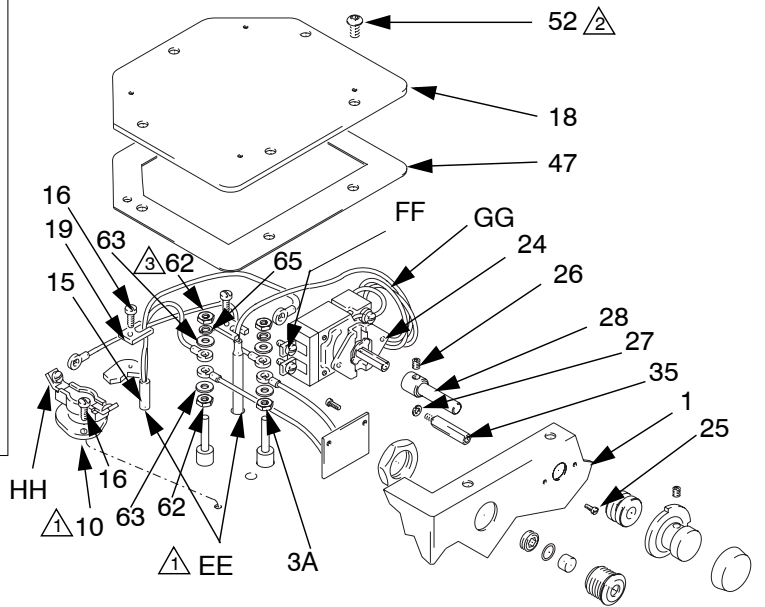
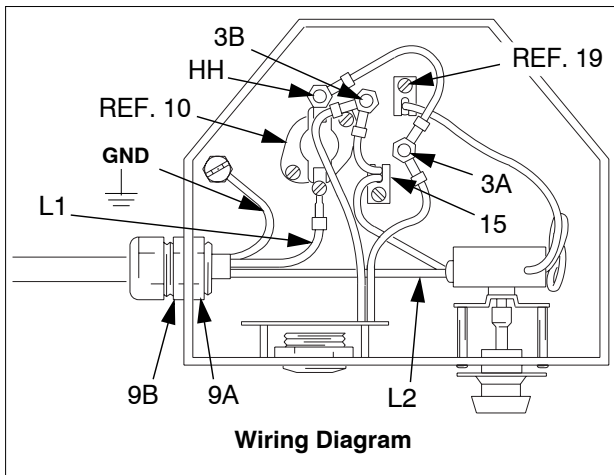

- ① Apply thermal lubricant
- ② Torque to 89 in-lb (10 N•m)
- ③ Torque nuts (62) to 13-14 in-lb (1.4-1.5 N•m)

T112337D

**FIG. 14: Thermostat Repair – Non-hazardous Heaters**

## Thermal Limit Sensor

### NOTICE

To avoid damaging the capillary tube (GG), which can cause heater malfunction, do not kink or nick the tube.

To avoid shorting out the heater, do not allow the capillary tube to contact the block terminal (3A).

1. Follow **Pressure Relief Procedure**, page 14.
2. Remove housing cover (18).
3. Remove nut (FF) and nut (3B) holding the leads of the thermal limit sensor (15) and remove the sensor. See FIG. 13 or 14, page 19.
4. Apply thin film of thermal lubricant (part no. 110009) to the thermal limit sensor (15) bulb and install a new sensor in the reverse order of disassembly. See **Reassembly Notes**, below.

## Control Knob

1. Follow **Pressure Relief Procedure**, page 14.
2. Turn knob (33) to setpoint 1.
3. Loosen setscrew (30) in the control knob (33).
4. Remove control knob (33).
5. Remove adjusting knob (12) from the control knob (33), and press fit it onto the new control knob. Check the bushing (29) and replace it if worn.
6. Position new knob (33) so setpoint 1 aligns with mark (JJ) on the housing (12:00 position) and the knob is about 1/16 in. (1 mm) away from the housing. Tighten setscrew (30).

## Heater Block

1. Follow **Pressure Relief Procedure**, page 14.
2. Remove housing cover (18).
3. *Hazardous Location Heater only:* Remove electrical junction box cover (4).
4. *Hazardous Location Heater only:* In the junction box (1B), disconnect the main power lead from the terminal of the post bushing (9A).  
*Non-hazardous Location Heater only:* Disconnect the main power lead from the primary thermostat (24).
5. *Hazardous Location Heater only:* In the electrical housing (1A), use a wrench on the flats of the post bushing (9A) to unscrew it from the housing.
6. See the appropriate sections on pages 18-20 to remove the primary thermostat and probe (24), the backup thermostat (10), the thermal limit sensor (15) and the control knob (33).
7. Remove the 6 screws (6) and lockwashers (5) holding the housing to the heater block (3).
8. Reassemble heater with the new block (3) in reverse order of disassembly.

## Reassembly Notes

- Refer to FIG. 13 or 14 for wiring connections.
- *Non-hazardous Location Heater only:* Make sure gasket (47) is installed and aligned with electrical housing screw holes.
- Secure cover (18) with lockwashers (5) and screws (6 or 52); torque screws to 89 in-lb (10 N•m).

- ⚠️ 1 Torque to 89 in-lb (10 N•m)
- ⚠️ 2 Electrical Housing
- ⚠️ 3 Junction Box
- ⚠️ 4 Apply sealant
- ⚠️ 5 Torque nuts (62) to 13-14 in-lb (1.4-1.5 N•m)

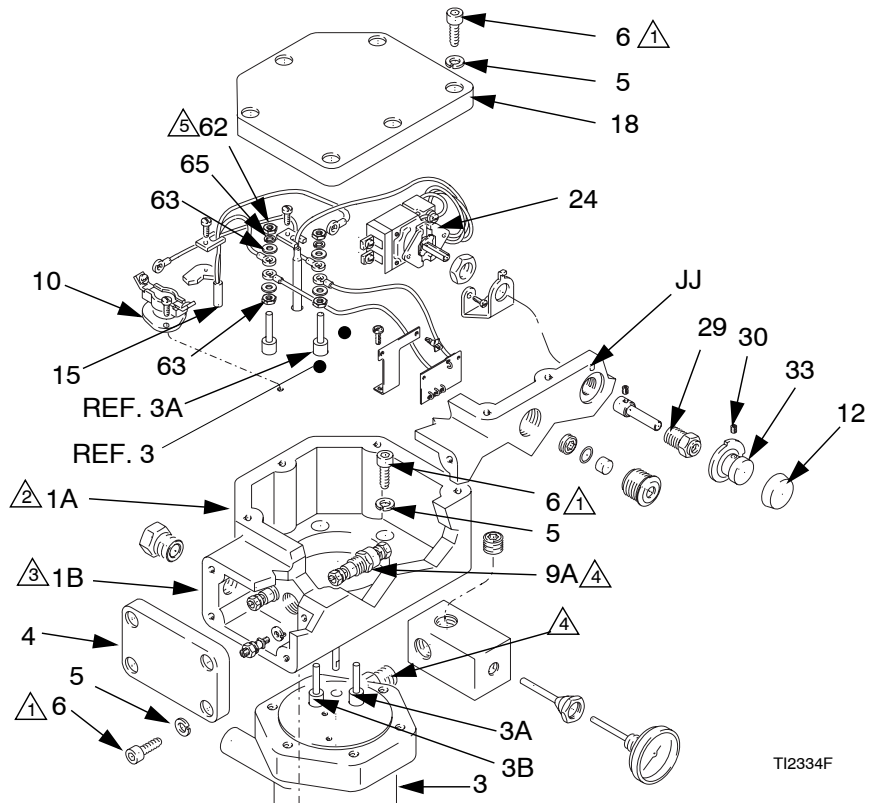

**FIG. 15: Control Repair – Hazardous Location Heaters**

- ⚠️ 1 Torque to 89 in-lb (10 N•m)
- ⚠️ 2 Electrical Housing
- ⚠️ 3 Apply sealant
- ⚠️ 4 Torque nuts (62) to 13-14 in-lb (1.4-1.5 N•m)

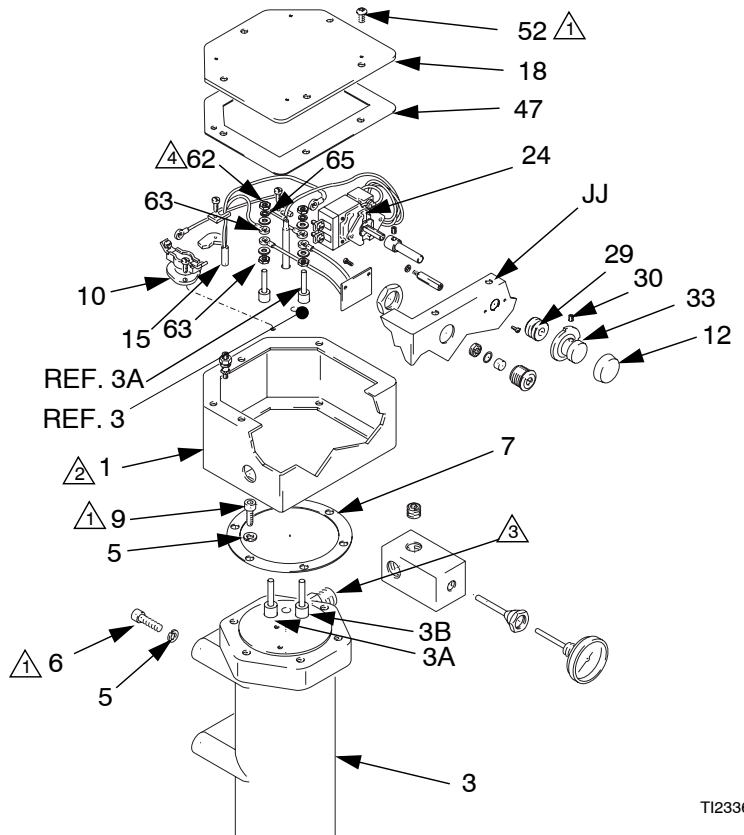

**FIG. 16: Control Repair – Non-hazardous Location Heaters**

# Parts

## Hazardous Location Heaters

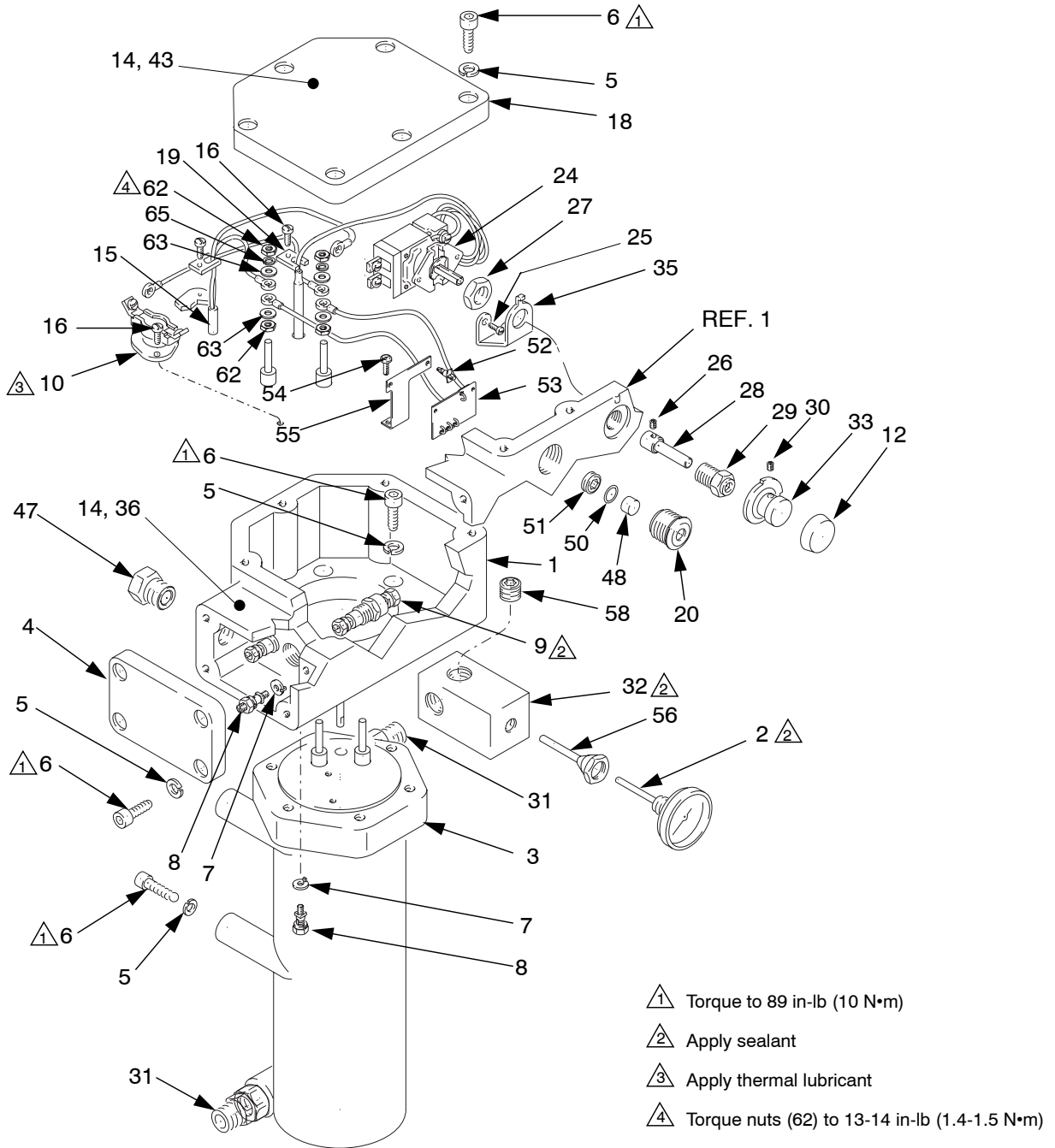

ti2334F

## Hazardous Location Heaters

Part No.	Series	Ref. No. 3 Heater Block Part No.	Volts / Watts
245848	C	246616	120 / 2300
245862	C	246617	200 / 4000
245863	C	246618	240 / 4000
245864	C	246619	480 / 4000
246254	C	246620	380 / 4000

Ref. No.	Part No.	Description	Qty	Ref. No.	Part No.	Description	Qty
1	183074	CONTROL HOUSING	1	22	105747	ALLEN WRENCH; 2 mm	1
2	102124	THERMOMETER DIAL	1	23	101369	ALLEN WRENCH; 0.0927 in.	1
3		HEATER BLOCK; see table; includes ref. no. 2, 31, 32, 56	1	24	108676	PRIMARY THERMOSTAT	1
4	183066	COVER	1	25	100032	SCREW; #6-32 UNC-2A	2
5	107542	LOCKWASHER	20	26	105672	SET SCREW; M4 x 0.7 x 6 mm	1
6	109114	SCREW; M8 x 1.25 mm	20	27	183070	NUT; M15 x 1.5	1
7	104582	WASHER	2	28	183068	SWITCH SHAFT	1
8	104029	GROUNDING CLAMP	2	29	183071	BUSHING; M15 x 1.5	1
9	108675	BUSHING; 1000 V max.; 250 A max.	2	30	101366	SET SCREW; #10-24 x 0.312 in.	1
10	108674	BACKUP THERMOSTAT	1	31	117344	FITTING; 5/8 in. OD tube x 1/2-14 npt(m)	2
11	235524	WIRE ASSEMBLY	1	32	15A808	T-FITTING	1
12	177969	KNOB	1	33	177968	KNOB	1
14	100055	SCREW; #6 type U	10	35	183067	BRACKET	1
15	223126	THERMAL LIMIT SENSOR, 152°	1	36▲	15B623	WARNING PLATE, English	1
16	105676	SCREW; M4 x 0.7 x 12 mm	4		15B777	WARNING PLATES, multilingual	1
18	183073	COVER	1	37	235523	WIRE ASSEMBLY	2
19	183072	BRACKET	2	42	102478	TIE STRAP	1
20	17D130	LIGHT HOUSING	1	43▲	15B625	WARNING PLATE, English	1
21	108664	ALLEN WRENCH; 6 mm	1		15B819	WARNING PLATE, multilingual	1
				47	185065	ADAPTER, 3/4 npt	1
				48	15B827	LIGHT LENS	1
				50	103338	O-RING; fluoroelastomer	1
				51	117483	SOCKET JAM SCREW; 5/8-18 x 5/16	1
				52	117514	SPACER	2
				53	246014	LIGHT CIRCUIT BOARD	1
				54	114669	SCREW; M5 x 10 mm	2
				55	15B243	BRACKET	1
				56	15D757	HOUSING, thermometer	1
				58	100361	PLUG, pipe; 1/2 npt	1
				62	100166	NUT, full hex	4
				63	102360	WASHER, flat	4
				65	112906	WASHER, lock, spring	2

▲ Replacement Danger and Warning labels, tags and cards are available at no cost.

## Non-Hazardous Location Heaters

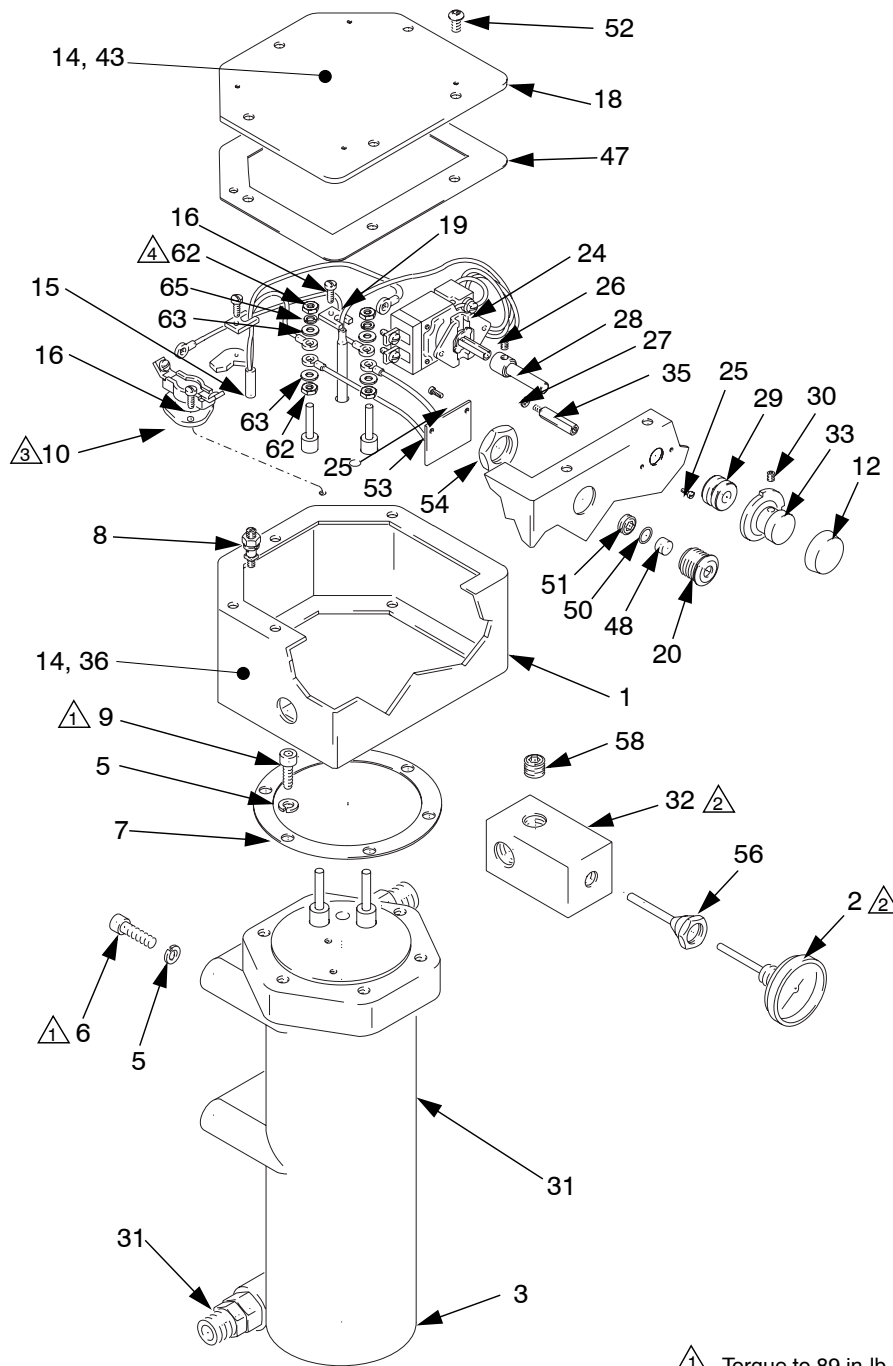

- ⚠️ 1 Torque to 89 in-lb (10 N•m)
- ⚠️ 2 Apply sealant
- ⚠️ 3 Apply thermal lubricant
- ⚠️ 4 Torque nuts (62) to 13-14 in-lb (1.4-1.5 N•m)

TI2336F



## Non-Hazardous Location Heaters

Part No.	Series	Ref. No. 3 Heater Block Part No.	Volts / Watts
245867	C	246616	120 / 2300
245868	C	246617	200 / 4000
245869	C	246618	240 / 4000
245870	C	246619	480 / 4000
246276	C	246620	380 / 4000
24J787	C	15A886	240 / 4000

Ref. No.	Part No.	Description	Qty
1	262891	ENCLOSURE	1
2*	102124	THERMOMETER DIAL	1
3		HEATER BLOCK; see table; includes ref. no. 2, 31, 32, 56	1
5	107542	LOCKWASHER	1
6	109114	SCREW	6
7	15A990	GASKET	2
8*	104029	GROUND CLAMP	2
9	117367	SCREW; M8 x 18 mm	6
10	108674	THERMOSTAT	1
11	235524	WIRE ASSEMBLY	1
12*	177969	KNOB	1
14	100055	SCREW; #6 type U	10
15*	223126	THERMAL LIMIT SENSOR, 152°	1
16	105676	SCREW; M4 x 0.7 x 12 mm	4
18	15A810	TOP COVER	1
19*	183072	BRACKET	2
20	15B828	LIGHT HOUSING	1
21*	108664	ALLEN WRENCH; 6 mm	1
22*	105747	ALLEN WRENCH; 2 mm	1
23*	101369	ALLEN WRENCH; 0.0927 in.	1
24*	108676	THERMOSTAT SWITCH	1
25*	100032	SCREW; #6-32 UNC-2A	4
26*	105672	SET SCREW	1
27*	114027	WASHER, #6	2
28*	183068	SWITCH SHAFT	1
29*	112738	GROMMET	2
30*	101366	SET SCREW; #10-24 x 0.312 in.	1
31	117344	FITTING; 5/8 in. OD tube x 1/2-14 npt(m)	2
32*	15A808	T-FITTING	1
33*	177968	KNOB	1
35*	117526	SPACER	2
36▲	15B623	WARNING PLATE, English	1
	15B777	WARNING PLATES, multilingual	1
37*	246346	WIRE ASSEMBLY	2
42*	102478	TIE STRAP	1
43▲	15B625	WARNING PLATE, English	1
	15B819	WARNING PLATE, multilingual	1
47	15A991	GASKET	1
48	15B827	LIGHT LENS	1
50	103338	O-RING; fluoroelastomer	1
51	117483	SOCKET JAM SCREW; 5/8-18 x 5/16	1
52	111962	SCREW; 1/4-28 UNRF-3A	5
53*	246014	LIGHT CIRCUIT BOARD	1
54	106216	NUT; 3/4-14 npsm	1
55*	100633	ALLEN WRENCH; 5/32	1
56*	15D757	HOUSING, thermometer	1
58*	100361	PLUG, pipe; 1/2 npt	1
62	100166	NUT, full hex	4
63	102360	WASHER, flat	4
65	112906	WASHER, lock, spring	2

▲ Replacement Danger and Warning labels, tags and cards are available at no cost.

\* Parts not used in 24J787.

# Accessories

## Heater Conversion Kit

**246302:** Includes two fittings to make VISCON HP ports match VISCON<sup>2</sup>

## Mounting Bracket

**192585:** European version (see below)

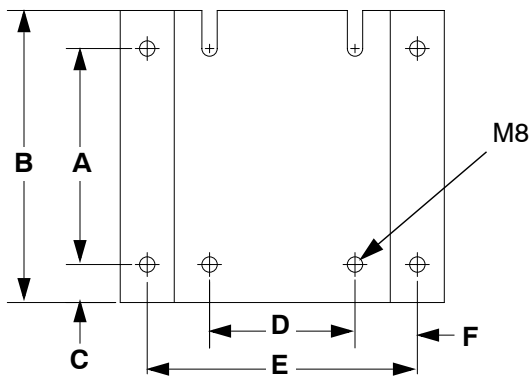

### Measurements – inches (mm)

A	B	C	D	E	F
5 (127)	6.76 (171.7)	0.88 (22.4)	3.37 (85.5)	6.25 (158.8)	1.44 (36.6)

**183982:** US / CAN version

G	H
6 (152)	5 (127)

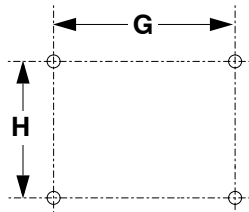

## Cart Bracket

Order 2 each of the following:

**183484:** Clamp

**183485:** Mounting bar

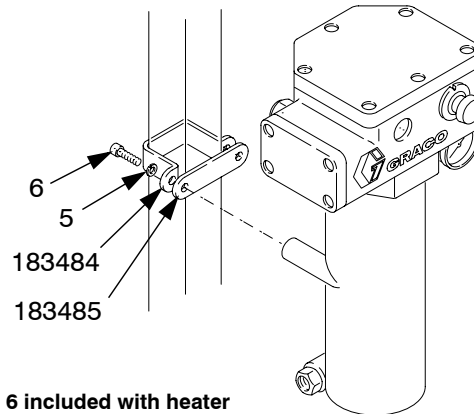

5 & 6 included with heater

05543

## Power Cord Set

**110160\*:** 600 V, 12 Awg, Extra Hard Usage Type St, High Temperature (221°F, 105°C) rated

**24W679:** 600 V, 12 Awg, Extra Hard Usage Type St, High Temperature (221°F, 105°C) rated

*\*Hazardous location heaters are no longer rated for use in a hazardous area when used with these accessories.*

## Thermal Lubricant

**110009:** 6.5 gram tube

# Technical Data

The heater can be used in the following environmental conditions: indoor use, 99% maximum relative humidity, pollution degree 2, installation category II, maximum ambient temperature 140° F (60° C).

Maximum Working Pressure	7250 psi (50 MPa, 500 bar)
Voltage / Wattage / Current*	See <b>Models</b> , page 2
Fluid Passage Area	182 in. <sup>2</sup> (117,419 mm <sup>2</sup> )
Fluid Passage Diameter	0.435 in. (11.1 mm)
Fluid Passage Length	133 in. (3383 mm)
Thermometer Range	64–250°F (-18–121°C)
Wetted Parts	Stainless Steel
Temperature Operating Range	84–219°F (-29–104°C)
Weight	39 lb. (17.6 Kg)

\* Main supply fluctuation not to exceed 10%.

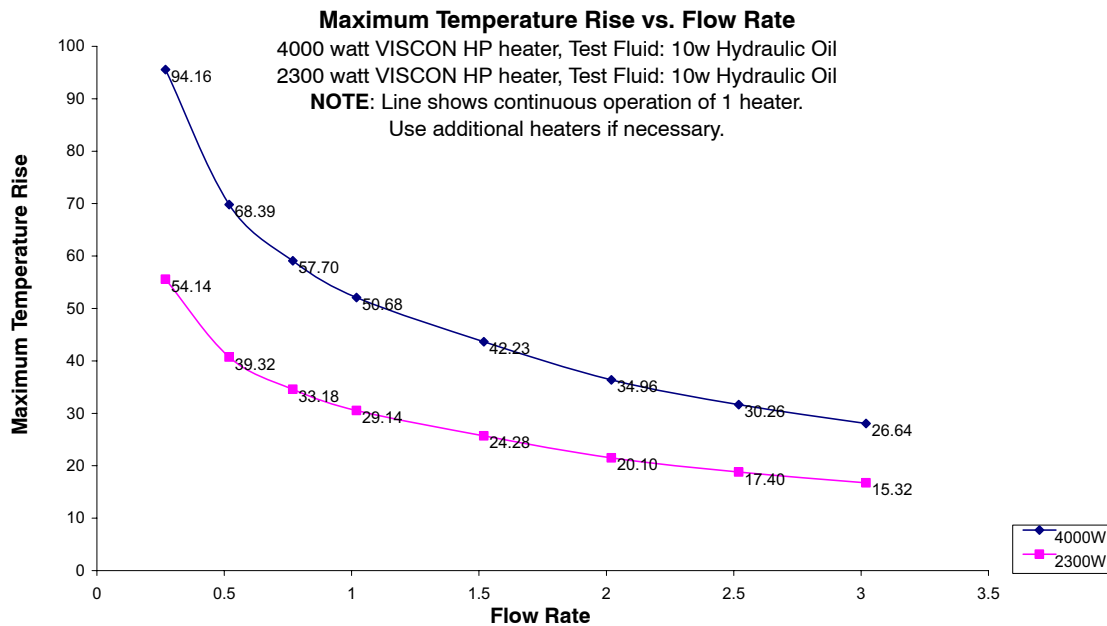

# Dimensions

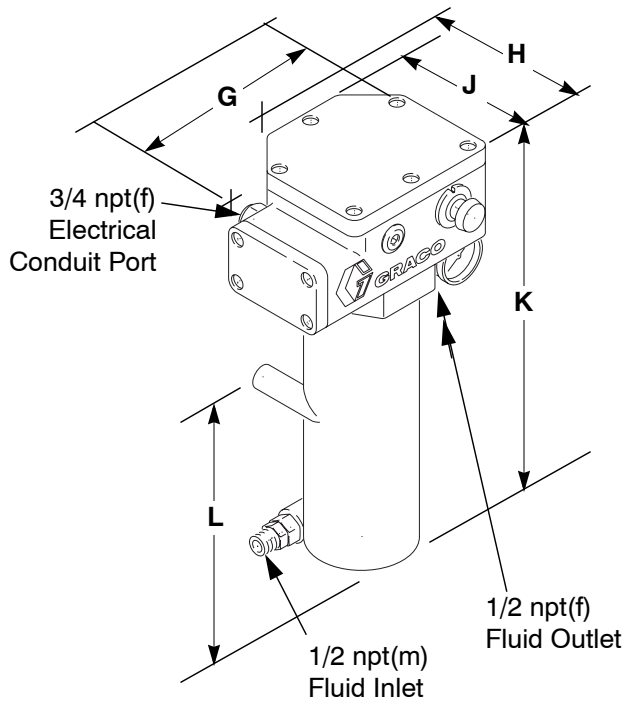

Measurements – inches (mm)

G	H	J	K	L
9.375 (238)	8.46 (215)	6.5 (165)	18 (457)	6.375 (162)



# Graco Standard Warranty

Graco warrants all equipment referenced in this document which is manufactured by Graco and bearing its name to be free from defects in material and workmanship on the date of sale to the original purchaser for use. With the exception of any special, extended, or limited warranty published by Graco, Graco will, for a period of twelve months from the date of sale, repair or replace any part of the equipment determined by Graco to be defective. This warranty applies only when the equipment is installed, operated and maintained in accordance with Graco's written recommendations.

This warranty does not cover, and Graco shall not be liable for general wear and tear, or any malfunction, damage or wear caused by faulty installation, misapplication, abrasion, corrosion, inadequate or improper maintenance, negligence, accident, tampering, or substitution of non-Graco component parts. Nor shall Graco be liable for malfunction, damage or wear caused by the incompatibility of Graco equipment with structures, accessories, equipment or materials not supplied by Graco, or the improper design, manufacture, installation, operation or maintenance of structures, accessories, equipment or materials not supplied by Graco.

This warranty is conditioned upon the prepaid return of the equipment claimed to be defective to an authorized Graco distributor for verification of the claimed defect. If the claimed defect is verified, Graco will repair or replace free of charge any defective parts. The equipment will be returned to the original purchaser transportation prepaid. If inspection of the equipment does not disclose any defect in material or workmanship, repairs will be made at a reasonable charge, which charges may include the costs of parts, labor, and transportation.

**THIS WARRANTY IS EXCLUSIVE, AND IS IN LIEU OF ANY OTHER WARRANTIES, EXPRESS OR IMPLIED, INCLUDING BUT NOT LIMITED TO WARRANTY OF MERCHANTABILITY OR WARRANTY OF FITNESS FOR A PARTICULAR PURPOSE.**

Graco's sole obligation and buyer's sole remedy for any breach of warranty shall be as set forth above. The buyer agrees that no other remedy (including, but not limited to, incidental or consequential damages for lost profits, lost sales, injury to person or property, or any other incidental or consequential loss) shall be available. Any action for breach of warranty must be brought within two (2) years of the date of sale.

**GRACO MAKES NO WARRANTY, AND DISCLAIMS ALL IMPLIED WARRANTIES OF MERCHANTABILITY AND FITNESS FOR A PARTICULAR PURPOSE, IN CONNECTION WITH ACCESSORIES, EQUIPMENT, MATERIALS OR COMPONENTS SOLD BUT NOT MANUFACTURED BY GRACO.** These items sold, but not manufactured by Graco (such as electric motors, switches, hose, etc.), are subject to the warranty, if any, of their manufacturer. Graco will provide purchaser with reasonable assistance in making any claim for breach of these warranties.

In no event will Graco be liable for indirect, incidental, special or consequential damages resulting from Graco supplying equipment hereunder, or the furnishing, performance, or use of any products or other goods sold hereto, whether due to a breach of contract, breach of warranty, the negligence of Graco, or otherwise.

## **FOR GRACO CANADA CUSTOMERS**

The Parties acknowledge that they have required that the present document, as well as all documents, notices and legal proceedings entered into, given or instituted pursuant hereto or relating directly or indirectly hereto, be drawn up in English. Les parties reconnaissent avoir convenu que la rédaction du présente document sera en Anglais, ainsi que tous documents, avis et procédures judiciaires exécutés, donnés ou intentés, à la suite de ou en rapport, directement ou indirectement, avec les procédures concernées.

# Graco Information

For the latest information about Graco products, visit [www.graco.com](http://www.graco.com).

**TO PLACE AN ORDER**, contact your Graco distributor or call to identify the nearest distributor.

**Phone:** 612-623-6921 **or Toll Free:** 1-800-328-0211 **Fax:** 612-378-3505

*All written and visual data contained in this document reflects the latest product information available at the time of publication.  
Graco reserves the right to make changes at any time without notice.*

Original instructions. This manual contains English. MM 309524

**Graco Headquarters:** Minneapolis

**International Offices:** Belgium, China, Japan, Korea

**GRACO INC. AND SUBSIDIARIES • P.O. BOX 1441 • MINNEAPOLIS MN 55440-1441 • USA**

**Copyright 2002, Graco Inc. All Graco manufacturing locations are registered to ISO 9001.**

[www.graco.com](http://www.graco.com)

Revision S, May, 2015