

3.1

Pressure relief valve direct operated

Type DBD...10

Sizes 6 to 30
up to 630 bar
up to 330 L/min



Contents

Function and configuration	02
Specification	03
Technical data	03
Characteristic curves	04
Unit dimensions	05-07

Features

- 3 connected versions
- Inserted cartridge
- Threaded connection
- Sub-plate mounting
- 7 pressure ratings
- 25, 50, 100, 200, 315, 400 and 630 bar
- 3 adjustment versions
- Adjusting bolt with protective cap
- Regulating handle
- Lockable regulating handle

Symbol

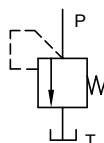

Function and configuration

The DBD pressure relief valves are direct operated, used to limit the pressure of hydraulic system. It comprises the sleeve (1), spring (2), poppet spool with damping (3) (pressure stages 25 to 400 bar) or ball spool (4) (pressure stage 630 bar) and pressure adjustment element (5). The system pressure may be set infinitely by the adjustment element. The spring (2) presses poppet spool (3) onto the valve seat. The channel P is connected to the system and the system pressure affect on the area of poppet (or ball) spool.

If the pressure in channel P rises in excess of the value set at the spring (2), the poppet spool (3) or ball spool (4) will opens against the spring (2). The pressure oil flows from channel P to channel T. The stroke of the spool is limited by spin shaft (6). To gain accurate setting value within the whole pressure range, the pressure scope is divided into 7 pressure ratings, and every rating has a corresponding spring which may be set maximum pressure.

03

Type DBDS...K. 10/...

pressure stages 25 to 400bar

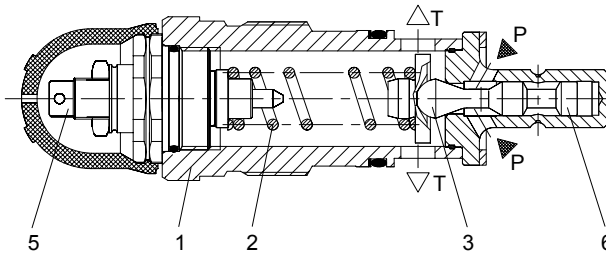

Type DBDH10K. 10/...

pressure rating 630bar (ball valve, only size 10)

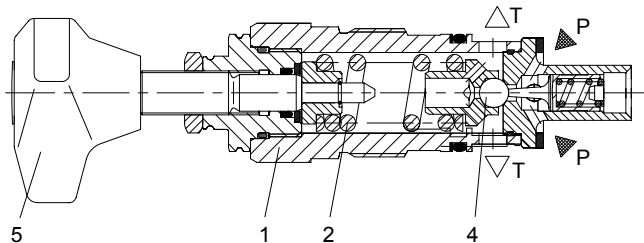

Notes:

Pressure relief valves, direct operated, type DBD has low internal leakage, and higher pressures at flow, and are suitable as a safety valve. Choose pilot operated pressure relief valves if lower adjustable pressure with low internal leakage is needed.

Specification

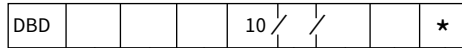

Pressure relief valve,
Direct operated

Further details
in clear text

Adjusting bolt with protective cap =S
Regulating handle =H
Lockable regulating handle
(up to size 10) =A

No code = NBR seals
V = FKM seals

For threaded connection valve
No code= Inch
2= Metric

Connection	G	K	P	
Nominal size	6= 6	6	6	6
	8= 8	-	-	-
	10= 10	10	10	10
	15= 15	-	-	-
	20= 20	20	20	20
	25= 25	-	-	-
	30= 30	30	30	30

Size

Size	10	6,8,15 and 20	25 and 30
Pressure ratings (up to...)	25 = 25bar	25 = 25bar	25 = 25bar
	50 = 50bar	50 = 50bar	50 = 50bar
	100 = 100bar	100 = 100bar	100 = 100bar
	200 = 200bar	200 = 200bar	200 = 200bar
	315 = 315bar	315 = 315bar	315 = 315bar
	400 = 400bar	400 = 400bar	400 = 400bar
	630 = 630bar	400 = 400bar	315 = 315bar

Connection version
Inserted cartridge =K
Threaded connection =G
Sub-plate mounting =P

10= 10 series

Technical data

Fluid	Mineral oil suitable for NBR and FKM seal					
	Phosphate ester for FKM seal					
Fluid temperature range	°C	-30 to +80 (NBR seal)				
		-20 to +80 (FKM seal)				
Viscosity range	mm ² /s	10 to 800				
Degree of contamination	Maximum permissible degree of fluid contamination: Class 9. NAS 1638 or 20/18/15, ISO4406					
Nominal size	6 and 8		10	15 and 20	25 and 30	
Operating pressure range	Inlet	bar	Up to 400	up to 630	up to 400	up to 315
	Outlet	bar	315			
Max. flow-rate	L/min	See the Characteristic curve				

Performance curves (Measured at $t=40^{\circ}\text{C} \pm 5^{\circ}\text{C}$, using HLP46)

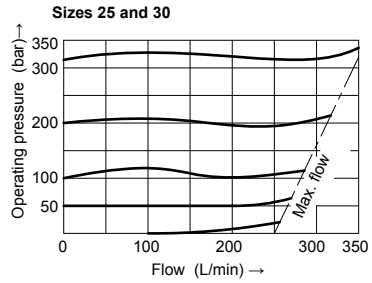
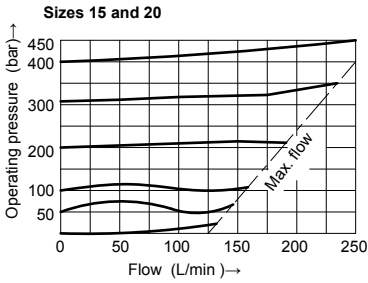
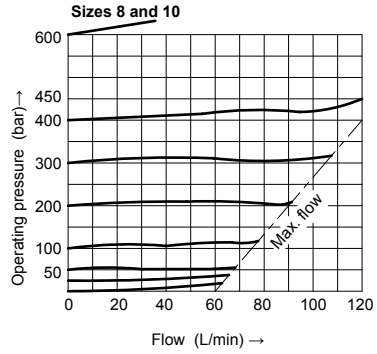
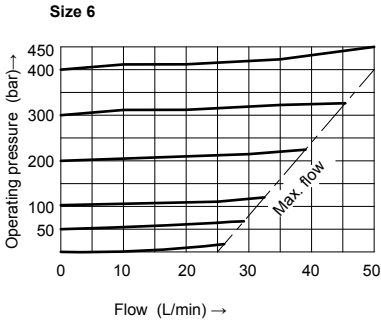

03

Unit dimensions

(Dimensions in mm)

• Cartridge cavity

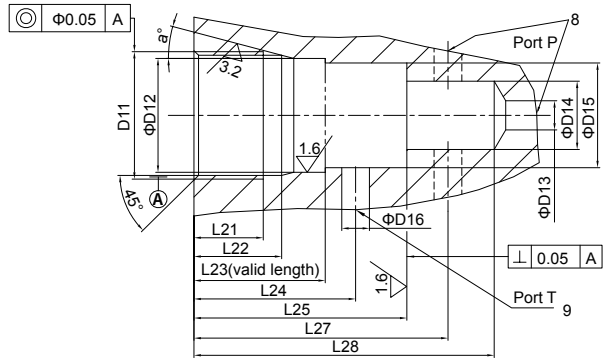

- 1 Adjustment element "S"
- 2 Adjustment element "H"
(use pressure adjustment handwheel for sizes 25 and 30)
- 3 Adjustment element "A"
- 4 Space required to remove the key
- 5 Steel seal (type, size)
- 6 Ring with mark
(after setting the pressure, aim the arrow at the zero position and then lock up the nut)
- 7 Internal hexagon screw S=6 for under size 20(SW4) and external hexagon S=13 for above size 25 (Sw5)
- 8 Port P arranged optionally around periphery or bottom
- 9 Port T arranged optionally around periphery

• Inserted valve

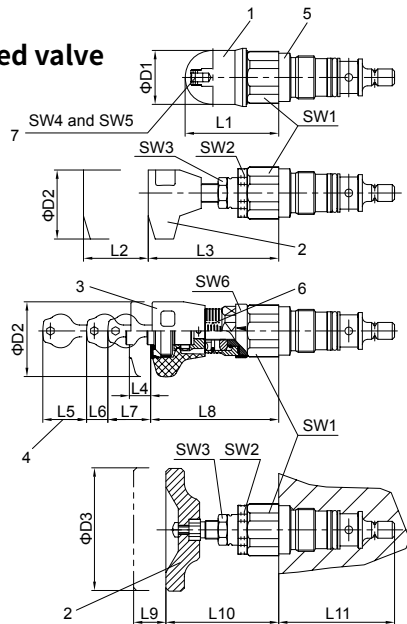

Size	Weight(kg)	D1	D2	D3	L1	L2	L3	L4	L5	L6	L7	L8	L9	L10	L11	SW1	Torque(Nm)	SW2	SW3	SW4	SW5	SW6	
6	Approx.0.4	34			72		88		11	20	11	30	83	-	-	64	32	80					
10	Approx.0.5	38	60	-	68	11	79					79			75	36	150	30	19	6	-	30	
20	Approx.1	48			65		77					77			106	46	250	36					
30	Approx.2.3	63	-	80	83	-	-	-	-	-	-	-	11	56	131	60	450	46				13	-
Size	D11	D12	D13	D14	D15	D16	L21	L22	L23	L24	L25				L27				L28	α			
6	M28×1.5	25H9	6	15	24.9	6	15	19	39	35	45				56.5±5.5				65	15			
10	M35×1.5	32H9	10	18.5	31.9	10	18	23	35	41	52				67.5±7.5				80				
20	M45×1.5	40H9	20	24	39.9	20	21	27		54	70				91.5±8.5				110	20			
30	M60×2	55H9	30	38.75	54.9	30	23	29	45	60	84				113.5±11.5				140				

Unit dimensions

(Dimensions in mm)

• Sub-plate mounting valve

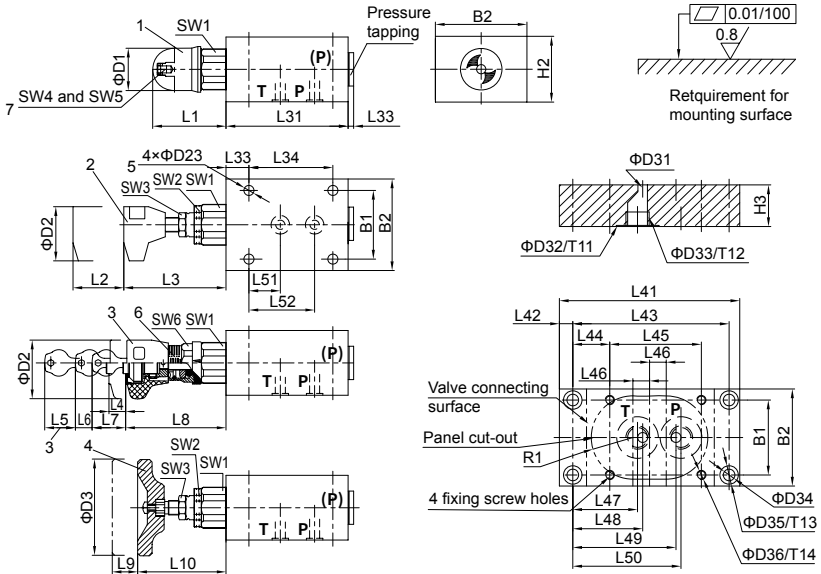

- 1 Adjustment element "S"
- 2 Adjustment element "H"(Sizes 25 and 30 use pressure adjustment handwheel)

- 3 Adjustment element "A"
- 4 Space required to remove the key
- 5 Valve fixing screw hole
- 6 Ring with mark(after setting the pressure, aim the arrow at the zero position and then lock up the nut)
- 7 Internal hexagon screw S=6 for under size 20(SW4) and external hexagon S=13 for above size 25 (SW5)

Size	O-ring (P and T)	Dimension of pressure tapping	Valve fixing hole (GB/T70.1-10.9)	Torque(Nm)
6	8.75×1.8	G1/4	M6×50	Approx.10
10	12.3×2.4	G1/2	M8×70	Approx.25
20	22×3	M27×2	M8×90	
30	34×3	M42×2	M10×110	Approx.50

Size	Weight(kg)	B1	B2	D1	D2	D3	D23	H2	L1	L2	L3	L4	L5	L6	L7	L8	L9	L10	L31	L32	L33	L34	
6	Approx. 1.6	45	60	34	60	-	6.6	40	72	11	83	11	20	11	30	83	-	-	80	2	15	55	
10	Approx. 3.7	60	80	38			9	60	68		79					79			79	79	79	79	79
20	Approx. 7.1	70	100	48	80	11	90	83	-	-	-	-	-	-	-	-	-	11	56	180	4	25	130
30	Approx. 15.7	100	130	63														11	90	83	11	90	83
SW1	SW2	SW3	SW4	SW5	SW6	Size	Sub-plate type	Weight(kg)	D31	D32	D33		D34	D35	H3	L41							
32	30	19	6	-	30	6	G300/1	Approx. 1.5	6	25	G1/4		7	11	25	110							
36	36					10	(G301/1)G302/1	Approx. 2	10	(28)34	(G3/8) G	11	25	135									
46	36					20	(G303/1)G304/1	Approx. 5.5	(15)20	(42)47	(G3/4) G1	11.5	17.5	40									
60	46					30	(G305/1)G306/1	Approx.8	30	(56)61	(G1 1/4) G11/2	11.5	17.5	40									
D36	L42	L43	L44	L45	L46	L47	L48	L49	L50	L51	L52	T11	T12	T13	T14	R1							
M6	8	94	22	55	10	39	42	62	65	20	40	15	15	9	15	25+2							
M8	10	115	27.5	70	12.5	40.5	48.5	72.5	80.5	21	45	1	(15)16	9	15	25+2							
	15	140	20	100	20	(45)42	54	85	(94)97	34	65		20	13	(12)22	40+3							
M10	12.5	165	17.5	130	22.5	42	52.5	102.5	(113)117	35	85	24	11.5	22	55+4								

China

+86 400 101 8889

America

+01 630 995 3674

Germany

+49 174 1386469

Japan

+81 03 6809 1696



© This brochure can be reproduced, edited, reproduced or transmitted electronically without the authorization of Hengli Hydraulic Company. Due to the continuous development of the product, the information in this brochure is not specific to the specific conditions or applicability of the industry, thus, Hengli does not take any responsibility for any incomplete or inaccurate description.