

4.7

Flow Control Valve

Type 2FRM6

Rectifier Plate

Type Z4S6

Size 6

Up to 315 bar

Up to 32 L/min



Contents

Function and configurations	02
Symbols	02
Ordering code	03
Technical data	04
Characteristic curves	05
Unit dimensions	06-09

Features

- For subplates see catalogue
- External closing of the pressure compensator, optional
- Check valve, optional
- Rotary knob with scale, optional lockable

Function and configurations

Flow control valve of type 2FRM is a two-way flow control valve, used for maintaining a constant flow and is independent of pressure and temperature. It consists of housing(1), knob rotary(2), orifice(3), pressure compensator(4), optional check valve(9).

Flow control valve 2FRM6B~L3X/~M

Flow from A to B is throttled at throttle channel (5). Throttle cross-section is varied by turning the knob rotary(2). To avoid effects of pressure at port B on constant flow, a compensator (4) is fitted. Spring (6) separately compress the compensator (4) and orifice (3) tightly.

Spring (6) compresses the compensator (4) tightly to maintain it open when no fluid flows through the valve. Once the fluid flows across the valve, the pressure in port A applies a force to pressure compensator (4) through the orifice (7).The pressure compensator (4) moves into the compensating position until the force is balanced. If the pressure in

port A rises, the compensator (4) moves to its closing direction until force is balanced again. Due to the compensator (4) continuous action, a constant flow is obtained.

2FRM6A~L3X/~R

The function of this valve is basically the same as that of valve type 2FRM6B~L3X/~R. However, pressure compensator (4) of this type of valve is connected with port P(11) so that pressure compensator(4) can be closed by external pressure. Any pressure in port P through the orifice (10) can make the compensator (4) closed against the force of compression spring (6).

When the directional valve (12) acts, fluid flows from P to B, control is achieved as type 2FRM6B. This flow controls the valve with the external pressure compensator which can be closed. It only works by controlling the inlet flow.

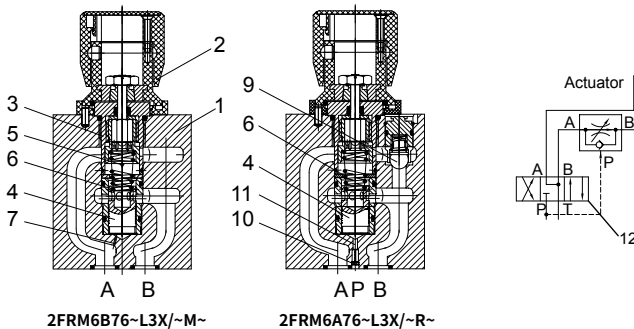

Symbols

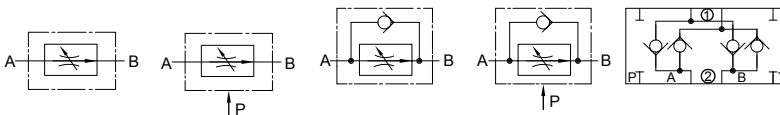

Type 2FRM6B ..L3X/~M

Type 2FRM6A ..L3X/~M

Type 2FRM6B ..L3X/~R

Type 2FRM6A ..L3X/~R

Rectifier type Z4S6-L1X

① = Valve side

② = sub-plate side

Ordering code

• For flow control valve

	2FRM	6			6	-	L3X	/				*
--	------	---	--	--	---	---	-----	---	--	--	--	---

Flow control valve

Nominal size 6 =6

With pressure compensator external close =A
(Restrains starting impact, can not work with Z4S6)

Without pressure compensator external close (Standard type) =B

Without pressure compensator external close (for meter plate mounting) =SB

Regulating element:
Lockable rotary knob with scale = 3
Rotary knob with scale = 7

Zero position of the markings at port P =L3X

L30 to L39 Series
(L30 to L39: unchanged installation and connection dimensions)

Further details in clear text

No code= NBR seals
V = FKM seals

R= With check valve
M= Without check valve

Flow (A → B)

0.2Q= up to 0.2L/min
0.6Q= up to 0.6L/min
1.5Q= up to 1.5L/min
3Q= up to 3.0L/min
6Q= up to 6.0L/min
10Q= up to 10.0L/min
16Q= up to 16.0L/min
25Q= up to 25.0L/min
32Q= up to 32.0L/min

• For rectifier plate

	Z4S	6	-	L1X	/		*
--	-----	---	---	-----	---	--	---

Rectifier

Nominal size 6 =6

L10 to L19 Series =L1X
(L10 to L19: unchanged installation and connection dimensions)

Further details in clear text

No code = NBR seals
V = FKM seals

Technical data

• Flow control valve

Max. operating pressure at port A		bar	315									
Pressure differential ΔP for free return flow B to A			See characteristic curves									
Minimum pressure differential		bar	6 to 14									
Pressure stability up to P= 315 bar		%	$\pm 2(Q_{max})$									
Flow -rate	Qmax	L/min	0.2	0.6	1.5	3	6	10	16	25	32	
	Qmin to 100bar	mL/min	15	15	15	15	25	50	70	100	250	
	Qmin to 315bar		25	25	25	25	25	50	70	100	250	
Fluid			Mineral oil suit, Phosphoric acid ester									
Fluid temperature range		°C	- 20 to + 80									
Viscosity range		mm ² /s	10 to 800									
Degree of contamination			Maximum permissible degree of fluid contamination: Class 9. NAS 1638 or 20/18/15, ISO4406									
Installation position			Optional									
Circumstances temperature range		°C	-20 to +50									
Weight	2FRM6A...2FRM6B...	kg	Approx.1.3									
	2FRM6SB...	kg	Approx.1.5									

• Rectifier

Nominal flow	bar	320
Maximum operating pressure	bar	To 210
Cracking pressure	bar	0.7
Weight	kg	Approx.0.9

Characteristic curves (Measured at $\vartheta_{oil}=40^{\circ}\text{C} \pm 5^{\circ}\text{C}$, using HLP46)

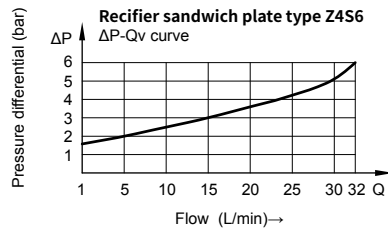
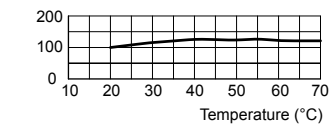
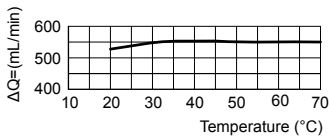
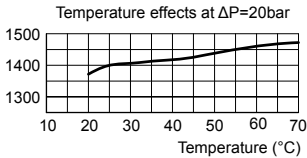
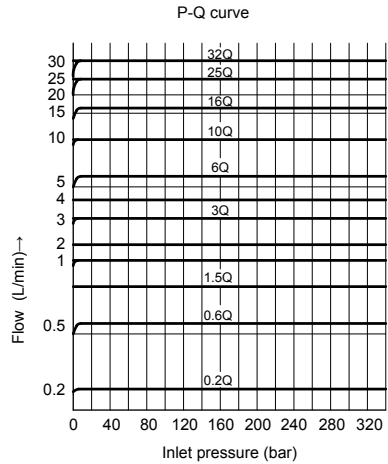
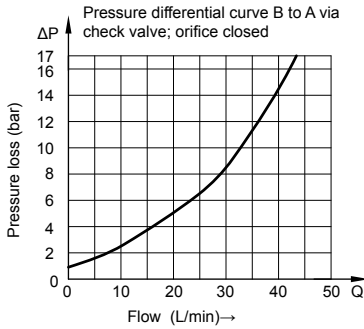
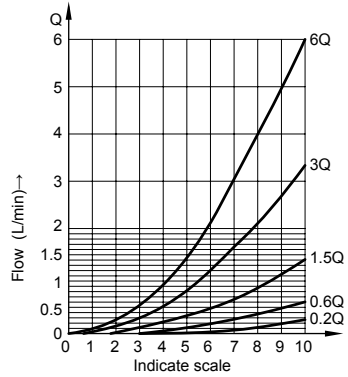
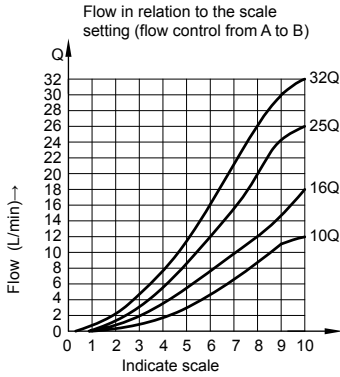

04

Unit dimensions

(Dimensions in mm)

Type 2FRM6A...and 2FRM6B

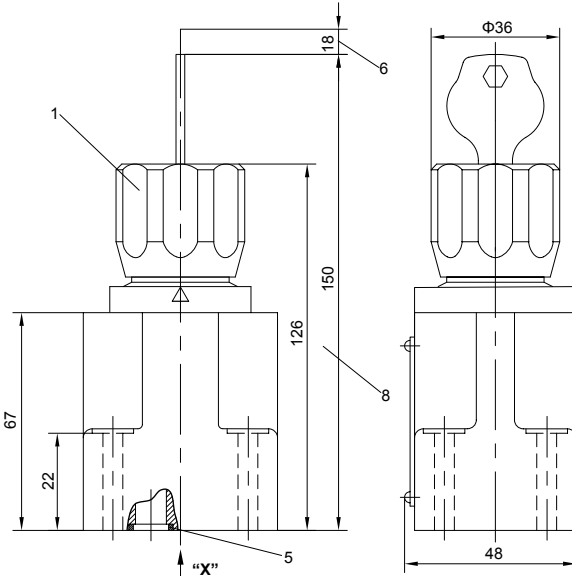

- 1 Lockable rotary knob with scale (adjustment element "3")
- 2 Name plate
- 3 Inlet "A"
- 4 Outlet "B"
- 5 O-rings 9.25×1.78 for ports A, B, P and T
- 6 Space required to remove key
- 7 Hole $\varnothing 3$ for version 2FRM6B is not drilled. (without external connection)
- 8 Rotary knob with scale (adjustment element "7")
- 9 Position of marking at port P, A, T or B

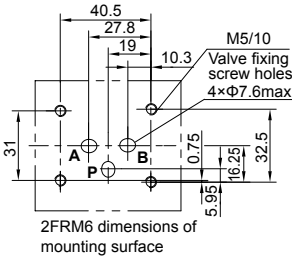
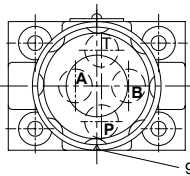
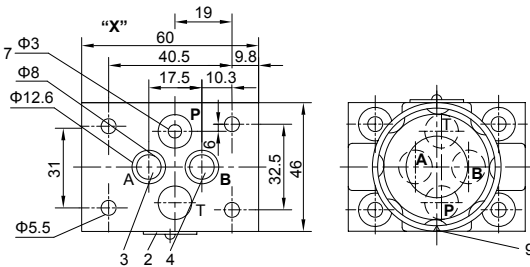

2FRM6 dimensions of mounting surface

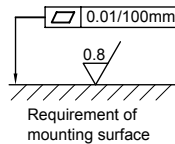

Valve fixing screws:

Without rectifier GB/T 70.1-M5×30-10.9, internal hexagon screw, tightening torque $M_A=8.9$ Nm.
 With rectifier GB/T 70.1-M5×70-10.9, internal hexagon screw, tightening torque $M_A=8.9$ Nm must be ordered separately.

Sub-plates:

Type G 341/01 (G 1/4)
 Type G 342 /01 (G 3/8)
 Type G 502/01 (G1/2)

Unit dimensions

(Dimensions in mm)

Type 2FRM6SB

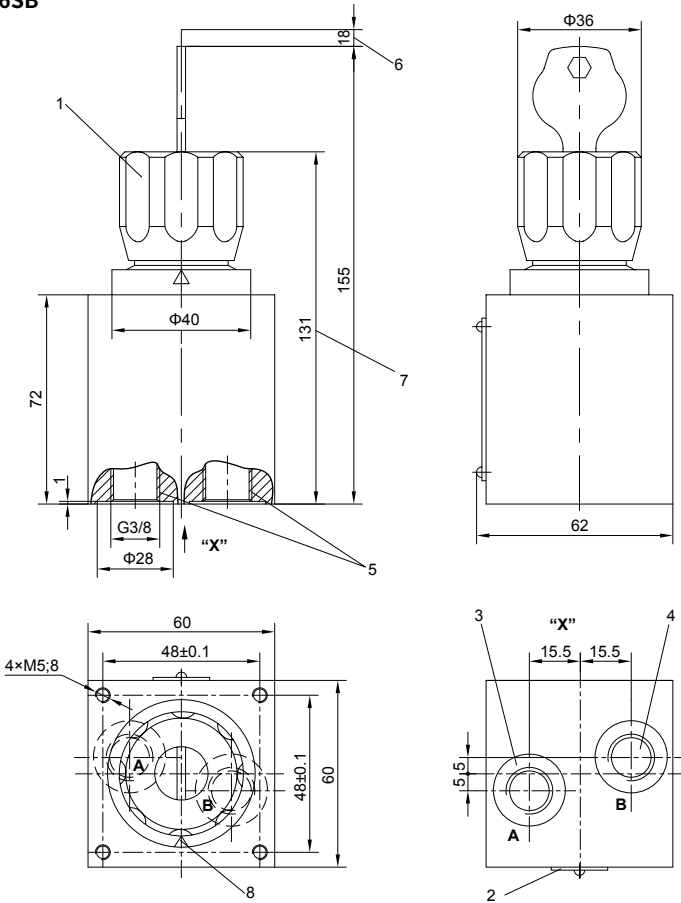

1 Lockable rotary knob with scale (adjustment element "3")

2 Name plate

3 Inlet a

4 Outlet "B"

5 Connection thread G 3/8 to ISO 228/1

6 Space required to remove key

7 Rotary knob with scale (adjustment element "7")

8 Position of marking opposite to the nameplate

Unit dimensions

(Dimensions in mm)

Transition plate AG5075

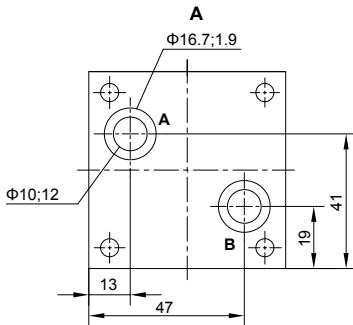
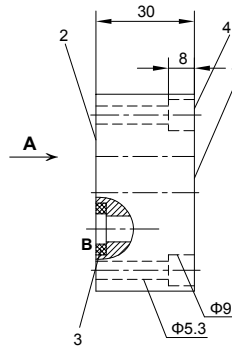
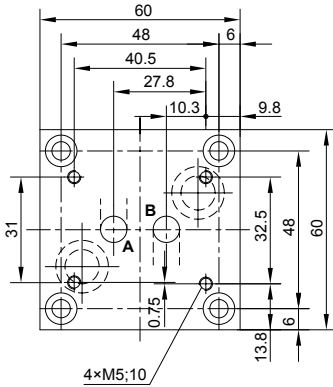

- 1 Mounting surface matching flow control valve Type 2FRM6
- 2 Mounting surface matching flow control valve Type 2FRM5
- 3 O-rings 12×2.5
- 4 **Valve fixing screws:**
M5×30 GB/T 70.1-10.9
internal hexagon screw
(Tightening torque $M_A = 6.1\text{Nm}$)

Note:

The transition plate type AG5075 is specially designed for mounting flow control valve type 2FRM6B...-L3X/.. onto an existing porting pattern of flow control valve type 2FRM5-30/...

Unit dimensions

(Dimensions in mm)

Rectifier type Z4S6-L1X

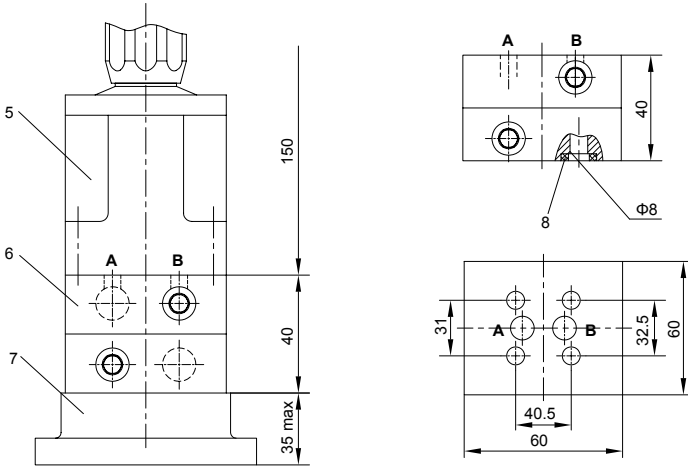

- 5 Flow control valve
- 6 Rectifier
- 7 Sub-plate
- 8 O-rings 9.25 × 1.78

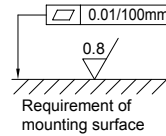

Caution:

Rectifier sandwich plate type Z4S6-L1X can not be used in conjunction with flow control valve type 2FRM6A...L3X/.. with built-in external connection of the pressure compensator.

China

+86 400 101 8889

America

+01 630 995 3674

Germany

+49 172 3683463

Japan

+81 03 6809 1696



© This brochure can be reproduced, edited, reproduced or transmitted electronically without the authorization of Hengli Hydraulic Company. Due to the continuous development of the product, the information in this brochure is not specific to the specific conditions or applicability of the industry, thus, Hengli does not take any responsibility for any incomplete or inaccurate description.