



4.8

## Flow control valve

Type 2FRM5,10,16

## Rectifier plate

Type Z4S5, 10, 16

Sizes 5, 10 and 16  
Up to 315 bar  
Up to 160 L/min



### Contents

Function and configuration	02
Specification	03
Technical data	04
Characteristic curves	05
Unit dimensions	06-08

### Features

- For subplates see catalogue
- External closing of the pressure compensator, optional
- Rotary knob with scale, optional lockable

## Function and configurations

Flow control valve type 2FRM is two-way flow control valve, consisting of pressure compensator and throttle valve in series. When fluid flows into the valve, it is reduced of pressure by the pressure compensator first and then throttled by the throttle valve. The flow in the flow control valve is able to maintain stable independent of any impact from the changing load because of pressure compensation function. Meanwhile the orifice is designed into the shape of a blade, making flow little influenced by variance of temperature. When the flow control valve is connected with a check valve in parallel, fluid can flow back in the opposite direction.

The rectifier plate of type Z4S is installed under the flow control valve to stabilize the flow in both directions of the valve.

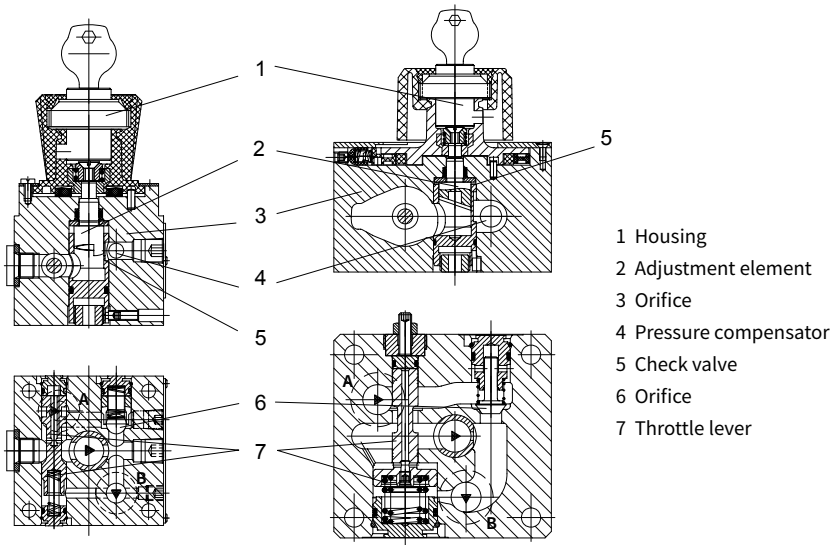

- 1 Housing
- 2 Adjustment element
- 3 Orifice
- 4 Pressure compensator
- 5 Check valve
- 6 Orifice
- 7 Throttle lever

Flow control valve section,  
type 2FRM5-30

Flow control valve section,  
type 2FRM10-20 and 2FRM16-20

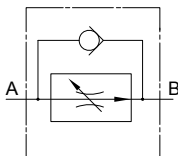

Symbol of flow control valve,  
type 2FRM



Symbol of rectifier,  
type Z4S

## Specifications

### • For flow control valve

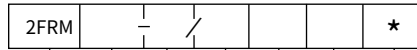

Flow control valve

Nominal size 5 = 5  
 Nominal size 10 = 10  
 Nominal size 16 = 16

30 Series(Nominal size 5) =30  
 20 Series(Nominal size 10 and 16) =20

#### Flow adjustment range (A → B)

Size=5	Size=10	Size=16
0.2L/min=0.2L	10L/min=10L	60L/min=60L
0.6L/min=0.6L	16L/min=16L	100L/min=100L
1.2L/min=1.2L	25L/min=25L	160L/min=160L
3L/min=3L	50L/min=50L	
6L/min=6L		
10L/min=10L		
15L/min=15L		

Further details in clear text

No code = NBR seals  
 V = FKM seals

No code = Pressure compensator, without stroke regulator  
 B = Pressure compensator, with stroke regulator

### • For rectifier plate

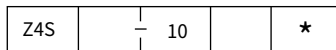

Rectifier

Size 5 = 5  
 Size 10 = 10  
 Size 16 = 16

10 Series = 10

Further details in clear text

No code = NBR seals  
 V = FKM seals

## Technical data

### • For flow control valve

Fluid	Mineral oil ;Phosphate ester														
Fluid temperature range	°C	-20~+80													
Viscosity range	mm <sup>2</sup> /s	10~800													
Degree of contamination	Maximum permissible degree of fluid contamination: Class 9. NAS 1638 or 20/18/15, ISO4406														
Item	Size	5						10				16			
Max. flow-rate	L/min	0.2	0.6	1.2	3	6	10	15	10	16	25	50	60	100	160
Pressure differential when backward flow B to A	bar	0.5	0.5	0.6	0.9	1.8	3.6	6.7	2	2.5	3.5	6	2.8	4.3	7.3
Flow stability range (-20°C ~+80 °C )%Qmax		±5	±3	±2				±2							
		±2( P= 210bar)						±2( P= 315bar)							
Working pressure	bar	210						315							
Min. pressure differential	bar	3~5			6~8			3~7			5~12				
Weight	kg	1.6						3.4				7.4			

### • For rectifier plate

Fluid	Mineral oil; Phosphate ester					
Fluid temperature range	°C	-20~+80				
Viscosity range	mm <sup>2</sup> /s	10~800				
Degree of contamination	Maximum permissible degree of fluid contamination: Class 9. NAS 1638 or 20/18/15, ISO4406					
Item	Size	5		10		16
Max. flow-rate	L/min	15		50		160
Working pressure	bar	210		315		315
Cracking pressure	bar	1		1.5		1.5
Weight	kg	0.6		3.2		9.3

**Characteristic curves** (Measured at  $t=40^{\circ}\text{C} \pm 5^{\circ}\text{C}$ , using HLP46)

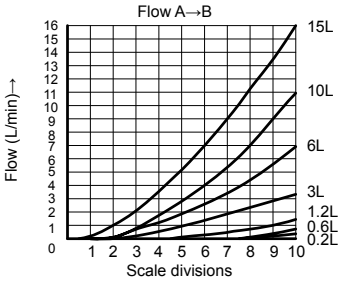

◀ Characteristic curve of flow control valve type 2FRM5

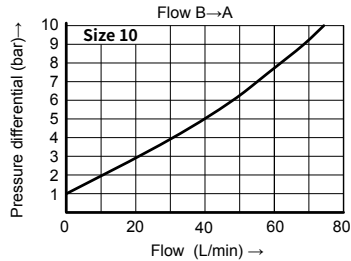
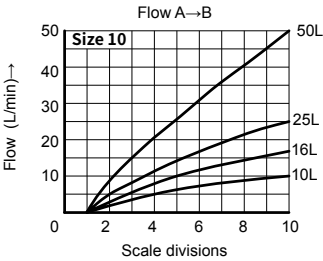

▲ Curve of flow control valve type 2FRM10

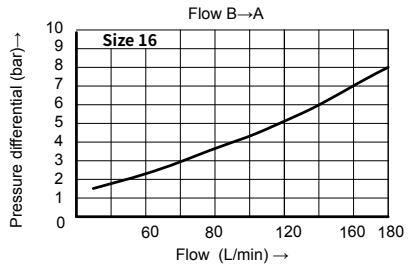
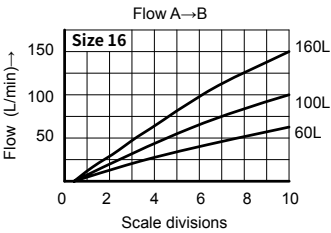

▲ Curve of flow control valve type 2FRM16

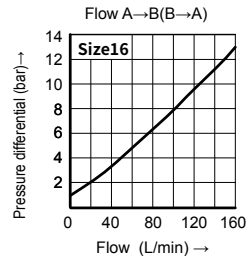
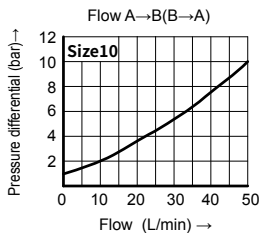
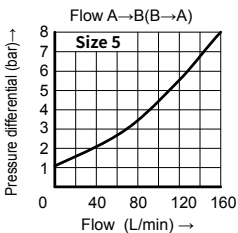

▲ Curve of rectifier plate type Z4S5

▲ Curve of rectifier plate type Z4S10

▲ Curve of rectifier plate type Z4S16



## Unit dimensions:

(Dimensions in mm)

### • Outline dimension of flow control valve type 2FRM10 and 2FRM16

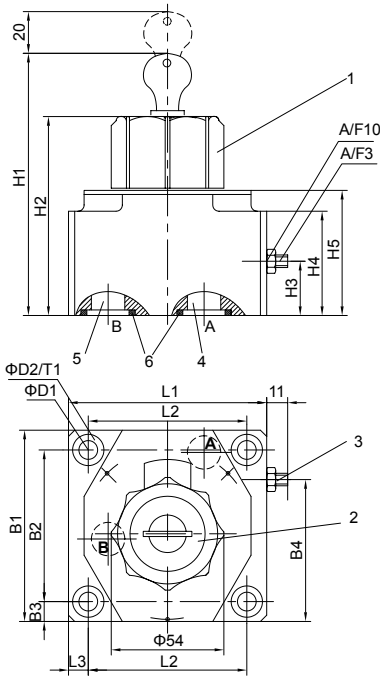

- 1 Lockable rotary knob
- 2 Name plate
- 3 Stroke regulator of pressure compensator
- 4 Inlet 'A'
- 5 Outlet 'B'
- 6 O-ring  
(Size 10:18.66×3.53 , Size 16:26.58×3.53)

#### Valve mounting screws:

**Size 10:** 4pcs M8×50 GB/T 70.1-10.9  
Tighten torque  $M_t=37\text{Nm}$

**Size 16:** 4pcs M10×80 GB/T 70.1-10.9  
Tighten torque  $M_t=75\text{Nm}$

**It must be ordered separately, if connection plate is needed**

#### Type:

**Size 10:** G279/01(02), G280/01(02)

**Size 16:** G281/01(02), G282/01(02)

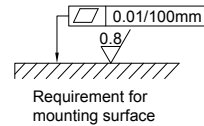

Szie	B1	B2	B3	B4	D1	D2	H1	H2	H3	H4	H5	L1	L2	L3	T1
10	101.5	82.5	9.5	68	9	15	125	95	26	51	60	95	76	9.5	13
16	123.5	101.5	11	81.5	11	18	147	117	34	72	82	123.5	101.5	11	12

### •Type 2FRM10 dimensions of mounting surface

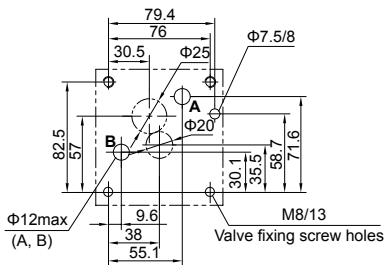

**Note:** No any holes within the area of  $\varnothing 20$  and  $\varnothing 25$ .

### •Type 2FRM16 dimensions of mounting surface

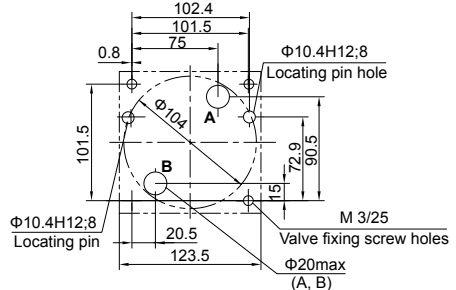

**Note:** No any holes within the area of  $\varnothing 104$ .

**Unit dimensions:**

(Dimensions in mm)

• **Outline dimension of rectifier type Z4S5**

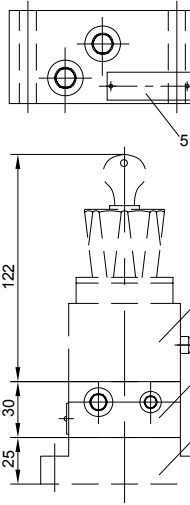
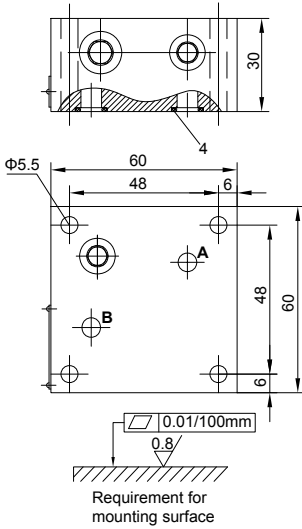

- 1 Flow control valve
- 2 Rectifier sandwich plate
- 3 Sub-plate
- 4 O-ring 12×2.5
- 5 Nameplate

**Valve mounting screws:**  
 4-M5×80 GB/T 70.1-10.9,  
 Tighten torque  $M_A=8.9Nm$

• **Outline dimension of rectifier Z4S10 and Z4S16**

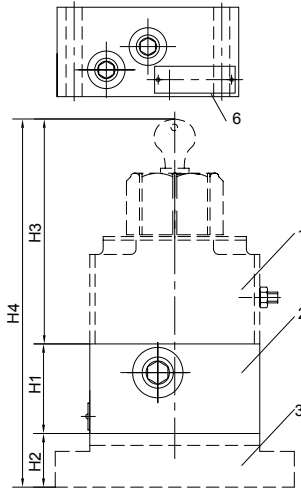
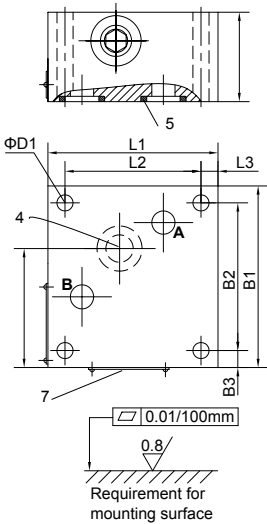

- 1 Flow control valve
- 2 Rectifier sandwich plate
- 3 Sub-plate
- 4 Gage hole
- 5 O-ring  
 (Size 10: 18.66×3.53 ,  
 Size 16: 26.58×3.53)
- 6 Nameplate(for size 10)
- 7 Nameplate(for size 16)

**Valve mounting screws:**  
 Size 10:  
 4pcs M8×100 GB/T 70.1-10.9  
 Tightening torque  $M_A=37Nm$   
 Size 16:  
 4pcs M10×160 GB/T 70.1-10.9  
 Tightening torque  $M_A=75Nm$

Size	B1	B2	B3	D1	H1	H2	H3	H4	L1	L2	L3
10	101.5	82.5	9.5	9	50	30	125	205	95	76	9.5
16	123.5	101.5	11	11	85	40	147	272	123.5	101.5	11