

## Miniature Quick Exhaust 10-32 UNF SQE

*Humphrey*

[www.humphrey-products.com](http://www.humphrey-products.com)

- Quick Exhausts Valve Series enhance the performance of air cylinders.

- Molded shuttle provides long cycle life and out performs flat-disk diaphragms in competitive designs.

- Can used as with shuttle valve, check valve, flow control valve.

- Super Quick Exhaust Valves are available in three smaller pipe port sizes: 10-32, 1/8" and 1/4".

- Super Quick Exhaust Valves use a specially designed molded shuttle with an enhanced seat area to prevent rupture.



Body Material	Zinc & Aluminum Die Cast, Zinc Plated Steel Fasteners
Pressure Range	0.0 - 150.0 PSIG
Lubrication	Not Required
Exhaust Port Size	.25 IN
Out Port Size	.125
Ambient Temperature Range	-25 - 180 F
Type of Operation	Quick Exhaust
Weight	2.72 OZ

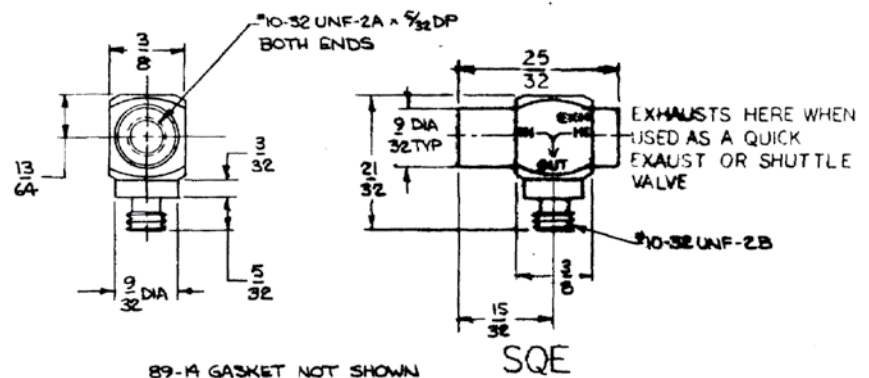
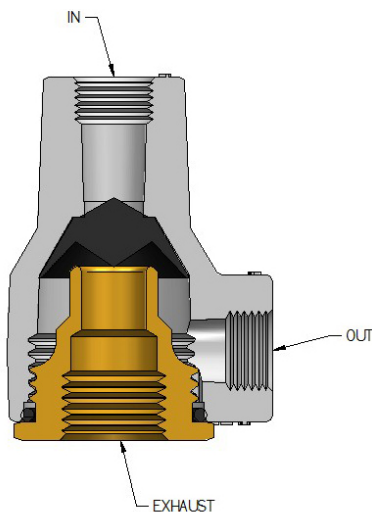

### HOW TO ORDER HUMPHREY VALVES AND ACCESSORIES

- Go to [www.humphrey-products.com](http://www.humphrey-products.com)
- Select "Find A Distributor" and input your information to locate a distributor nearest you.
- Or, call Customer Service at 1-800-477-8707 for the name and phone number of your local distributor.

*Humphrey*

**HUMPHREY PRODUCTS ARE SOLD WORLD-WIDE  
THROUGH AUTHORIZED DISTRIBUTORS**

### HOW TO OBTAIN A 3D CAD DRAWING

- Go to [www.humphrey-products.com](http://www.humphrey-products.com)
- Using Internet Explorer 6.0 or later for Windows, select "Online Product Guide"
- Follow the steps to choose the valve you need.
- At "Product Overview" section, select "IE CAD VIEW" to download.

Information on this spec sheet is considered to proprietary to Humphrey. Specifications subject to change without notice. Please read WARNING and GENERAL GUIDELINES before using any Humphrey products.