

Description

Series BD servovalves provide high resolution in the control of position, velocity and force in motion control applications.

Features

- Rugged reliable trouble-free operation.
- Reduced contaminant sensitivity.
- Linear flow gain characteristics.
- Intrinsically safe model available.
- Explosion proof model available.

Operation

When used in conjunction with Series BD90 and BD101 servo amplifiers or a motion controller, Series BD valves will provide accurate control of rotary and linear actuators.

Specifications

Rated Flow @ 1000 PSI ΔP	3.78–151 LPM (1.0 – 40 GPM)	
Linearity	≤ 5%	
Hysteresis	≤ 3%	
Threshold	≤ 0.5%	
Fluid	Mineral oil, 60–225 SSU, max. 1000 SSU	
Oper. Temp.	-1 to +82°C (+30 to +180°F)	
Pressure Gain	3% of spool shift	
Null Shift with Temperature	< ± 2% per 38°C (100°F)	
Null Shift with Supply Pressure	< 2% per 69 Bar (1000 PSI)	
Quiescent Flow (Std. Spool Lap)	BD15 – 1.5–2.1 LPM (.40–.55 GPM) BD30 – 2.1–3.78 LPM (.55 – 1.0 GPM)	
Step Response Input	Model	Typical Step Response Input
	BD15	10 to 90%, 26 ms
BD30	10 to 90%, 30 ms	
Pressure Ranges For optimum performance, Parker Servo Valves are designed to operate within specific system supply pressure ranges.		
<u>System Supply Pressure</u>		
180–210 Bar (2600–3000 PSI)	48–66 Bar (700–950 PSI)	
138–172 Bar (2000–2500 PSI)	14–45 Bar (200–650 PSI)	
95–133 Bar (1400–1950 PSI)	0–210 Bar (0–3000 PSI)	
68–90 Bar (1000–1300 PSI)	External Pilot	
Filtration	SAE Class 3 or better, ISO Code 17/15/12	
Protection Class	NEMA 1 (IP54)	

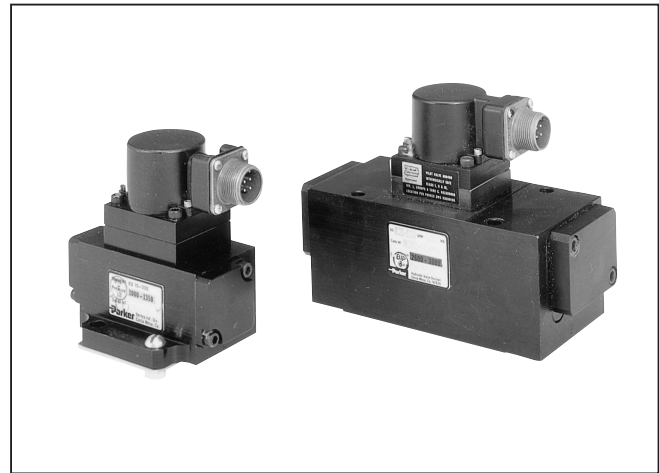

Flow–Load Characteristics

Control flow to the load will change with load pressure and valve current as shown in figure 1. These characteristics closely follow the theoretical square–root relationship for sharp–edged orifices as illustrated in the equation below.

$$Q = K \sqrt{\Delta P}$$

- Q = Control flow, cubic inches/sec
- K = Valve constant
- ΔP = Valve pressure drop

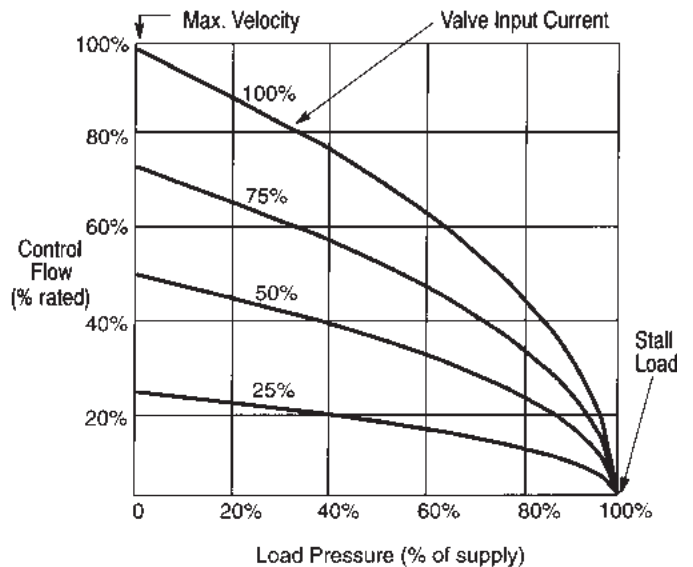
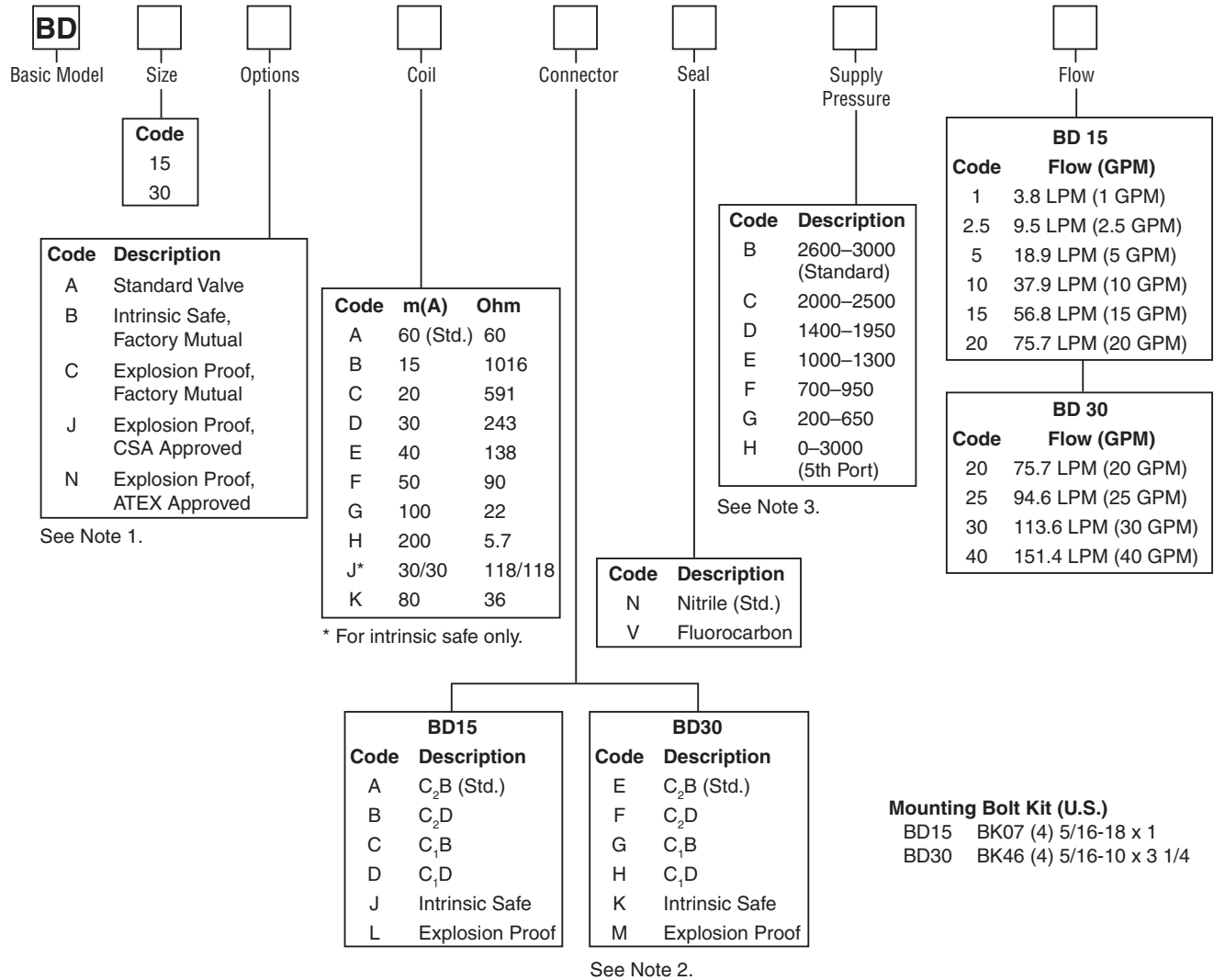

Figure 1. Change in flow with current and load pressure

Quick Reference Data Chart

Model	Flow Capacity @ 1000 PSID LPM (GPM)	Max. Pressure Rating	Max. Tank Pressure	Port Circle	Electrical Input (Std.) Single Coil	Coil Resistance (Std.) Each Coil	Weight
BD15	3.8, 9.5, 19, 37, 57, 76 (1, 2.5, 5, 10, 15, 20)	210 Bar (3000 PSI)	14 Bar (200 PSI)	.875	60 mA (Full Flow)	60 ohms	1.2 kg (2.6 lbs.)
BD30	76, 95, 113, 151 (20, 25, 30, 40)	210 Bar (3000 PSI)	14 Bar (200 PSI)	1.75	60 mA (Full Flow)	60 ohms	2.9 kg (6.3 lbs.)



Note 1: “B” Intrinsic Safe Option meets Factory Mutual Intrinsically Safe Class I, II and III, Division 1 Groups A through G. Refer to Parker Bulletin 1452.

“C” Explosion Proof meets:
 Factory Mutual Explosion Proof
 Class I, II, III, Division 1, Groups A through G

“J” Explosion Proof meets:
 Canadian Standards Association
 Class I, Groups A through D
 Class II, Groups E, F and G
 Class III
 Refer to Parker Bulletin 1451.

“N” Explosion Proof meets:
 ATEX Ex⊕II2G EExm II T3 T_{amb} 45°C to -50°C
 Request Parker Documentation Package: 1200074

Note 2: Connector Location & Flow Polarity
 (Standard connector over C₂ + to B = P to C₁ flow).
 C₂B = Connector over Port C₂ + to Pin B = P to C₁ flow.
 C₂D = Connector over Port C₂ + to Pin D = P to C₁ flow.
 C₁B = Connector over Port C₁ + to Pin B = P to C₁ flow.
 C₁D = Connector over Port C₁ + to Pin D = P to C₁ flow.

Note 3: Supply Pressure: Code “H” applies to 5th Port/External Pilot Option. This requires the use of a blank orifice “-00”. First stage pressure should be limited to 41.4 Bar (600 PSI) and no less than 27.6 Bar (400 PSI).
 Servo valve rated flow at 1000 PSID ±10%.

Accessories

Model	Description	Model	Description
6522A11	1/16" Hex Allen Wrench	820089-1	BD30 Servovalve Shipping Container
810005-1	Orifice Filter	BD830008	BD90/95 Amplifier Board Shipping Container
810013-**	Valve Orifice Kit, Fluorocarbon		
810014-**	Valve Orifice Kit, Nitrile	810089-1	BD15 Servovalve Shipping Container
**Dash #	Operating Pressure	820000TF3	Filter Wrench
-16	180 – 210 Bar (2600 – 3000 PSI) B	MS3106E-14S-2S	SV Mating Connector
-18	138 – 176 Bar (2000 – 2550 PSI) C		
-20	96 – 134 Bar (1400 – 1950 PSI) D		
-22	69 – 93 Bar (1000 – 1350 PSI) E	1200127	Flushing valve for BD15
-33	48 – 66 Bar (700 – 950 PSI) F	1200128	Flushing valve for BD30
-50	14 – 45 Bar (200 – 650 PSI) G	810107	BD15 Block off Plate
-00	0 – 210 Bar (0 – 3000 PSI) 5th Port H		

Adapters

□
Type of Adapter

Code	To Mount A _____	Onto A _____	Pattern
810092-1	BD15	BD30 (1.75)	
810093-5	BD15	D05	
810094-5	BD15	D03	
810098-1	BD15	.937 Port Circle	
810097-3	BD15	.785 Port Circle	
810096-5	BD15	.625 Port Circle	
820006-1	BD30	Moog 62-303B & Atchley 231	
820007-1	BD30	D08	
820091-1	BD30	BD15 (.875)	
Consult Factory	BD30	1.375	
Consult Factory	BD15	D05H	

— □
Seals

Code	Description
Omit	Nitrile
V	Fluorocarbon

Subplates

Valve Model	Subplate	Port Size	Location	Bolt Kit	Torque Specifications (Lubricated)
BD15	810090-3	SAE12	Side	BK07	17 ft. lbs.
BD30	820090-3	SAE16	Side	BK46	17 ft. lbs.

Cables

EHC
 Electrohydraulic
 Cable for BD
 Series Valves

□
Length

Code	Length
9	Length
15	in Feet

4
Cable Type

Code	Description
4	4-wire, 20 awg. shielded (Belden 9402)

S
Pin Orientation

Code	Description
S	BD Series

Series BD15

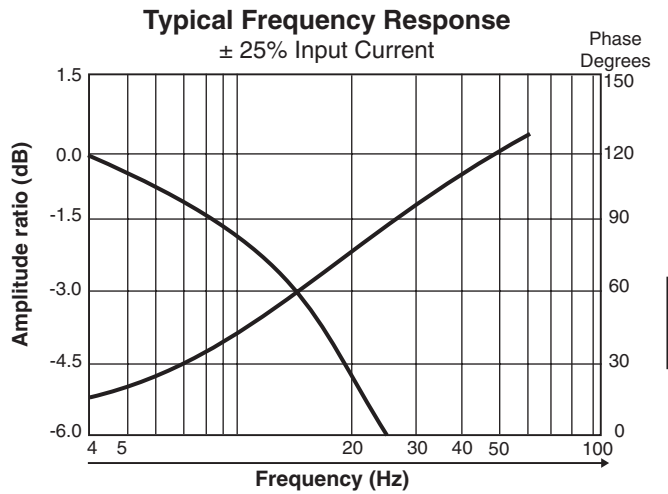
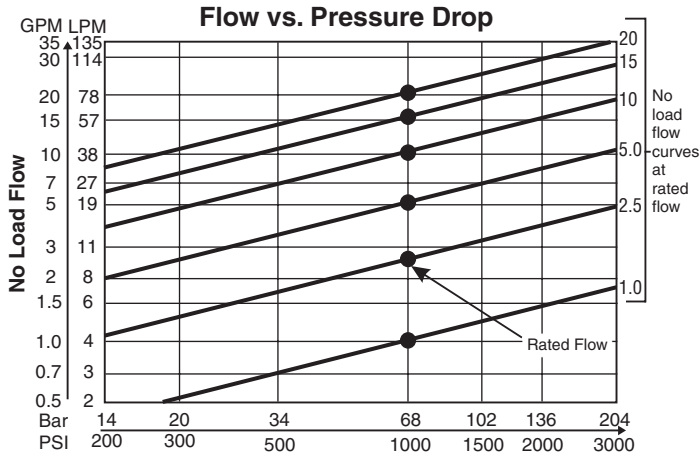

Series BD30

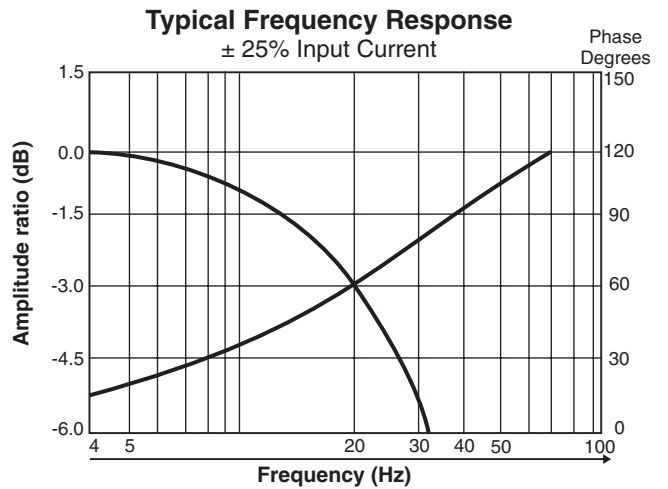
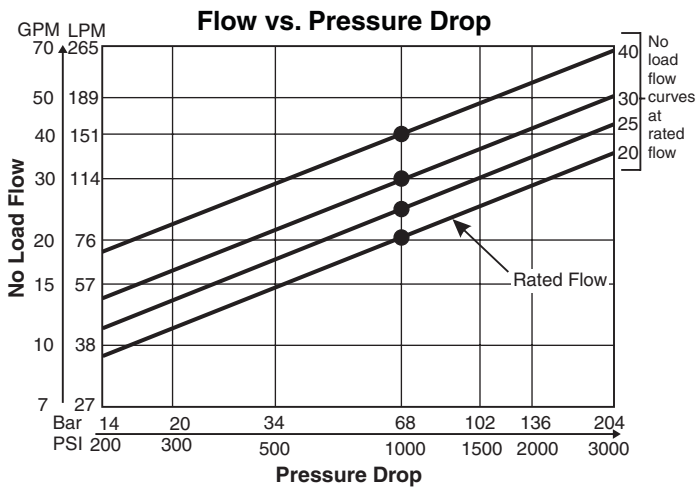

Inch equivalents for millimeter dimensions are shown in (**)

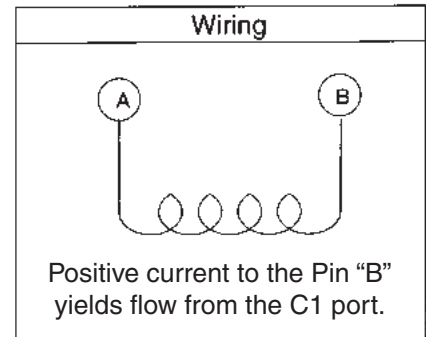
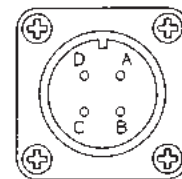
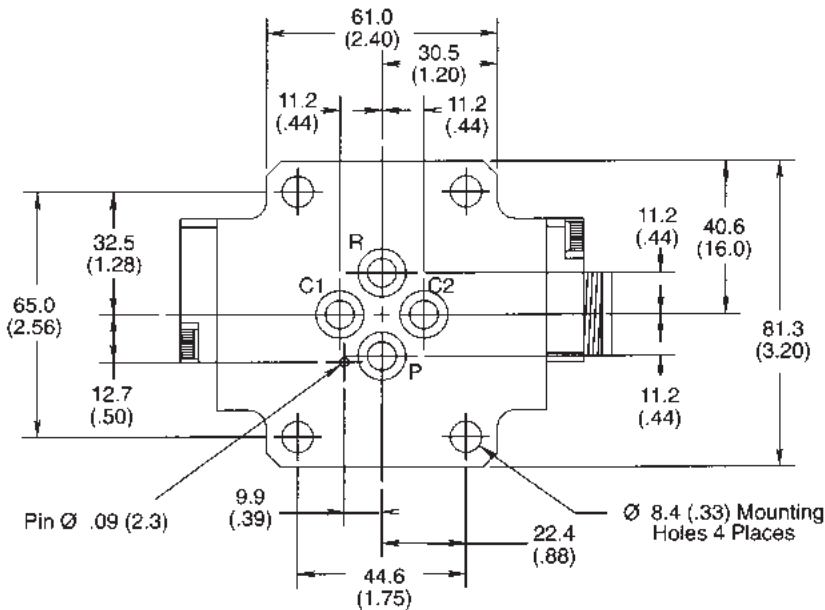
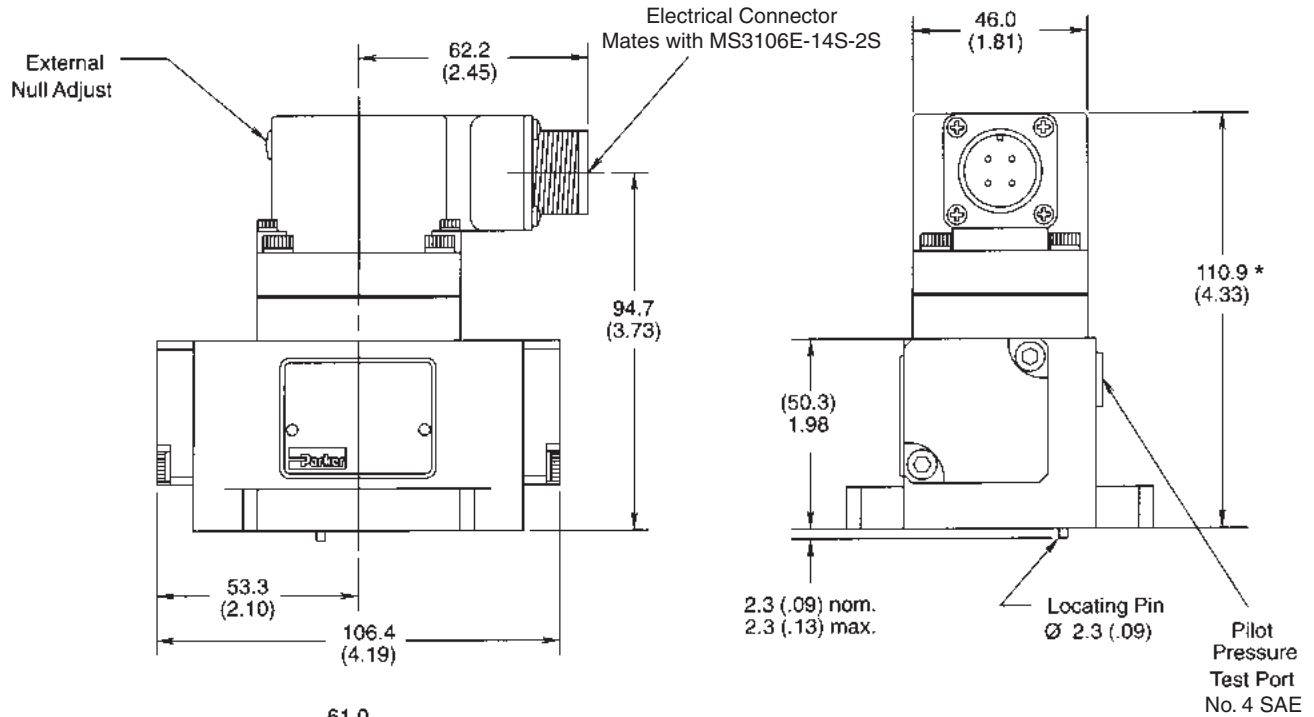

Note: Valve mating surface to be flat within 0.002 TIR, and smooth to within 63 RMS

* 140 (5.50) for BD15C; explosion proof, FM approved.

Note: Vertically oriented 1/2 NPT threaded male conduit connection with lead wires (not as shown).

C

Inch equivalents for millimeter dimensions are shown in (**)

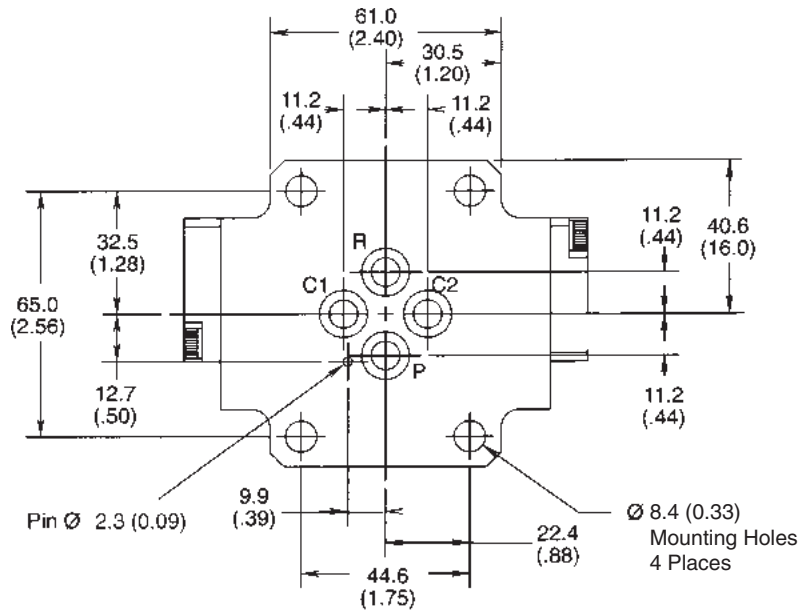
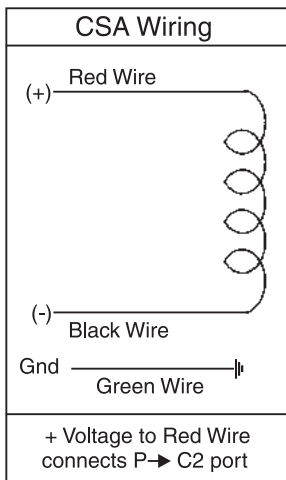
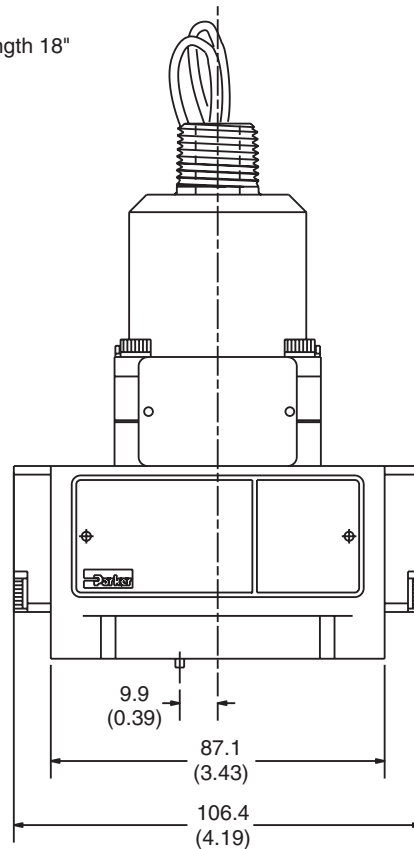
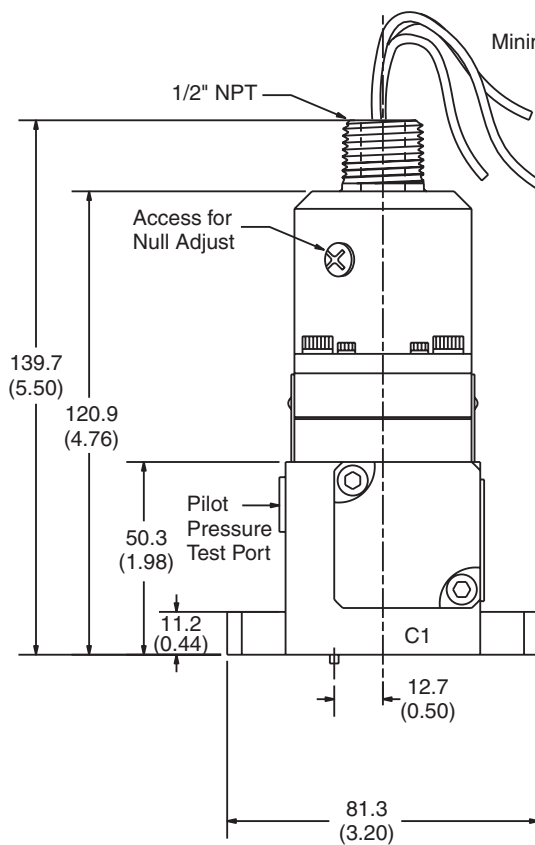

Note: Valve mating surface to be flat within 0.002 TIR, and smooth to within 63 RMS



Dimensions

Series BD15, ATEX Version BD15N*L

Inch equivalents for millimeter dimensions are shown in (**)



C

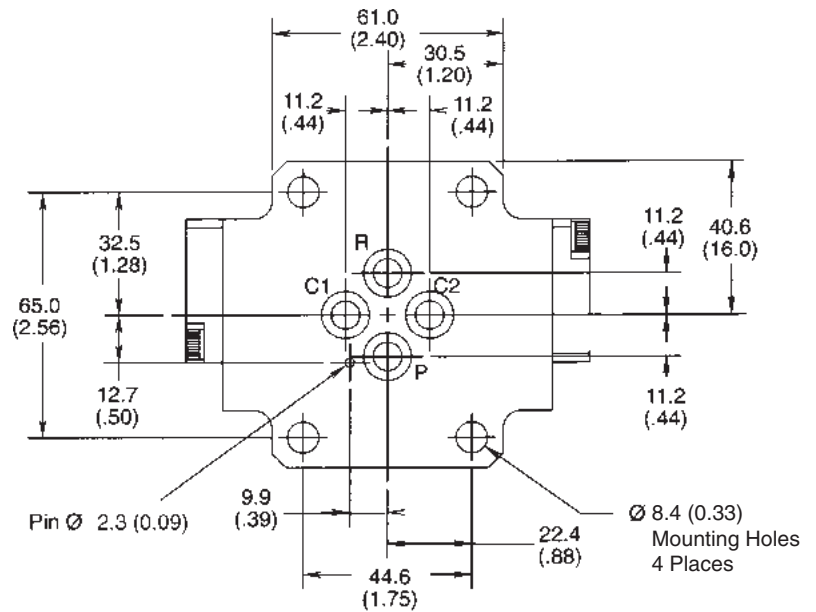
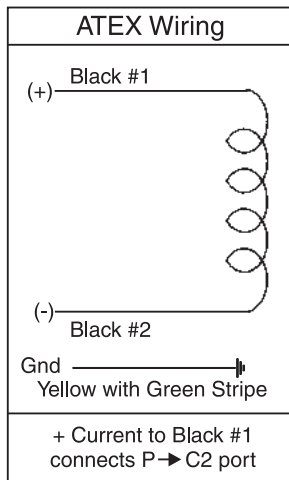
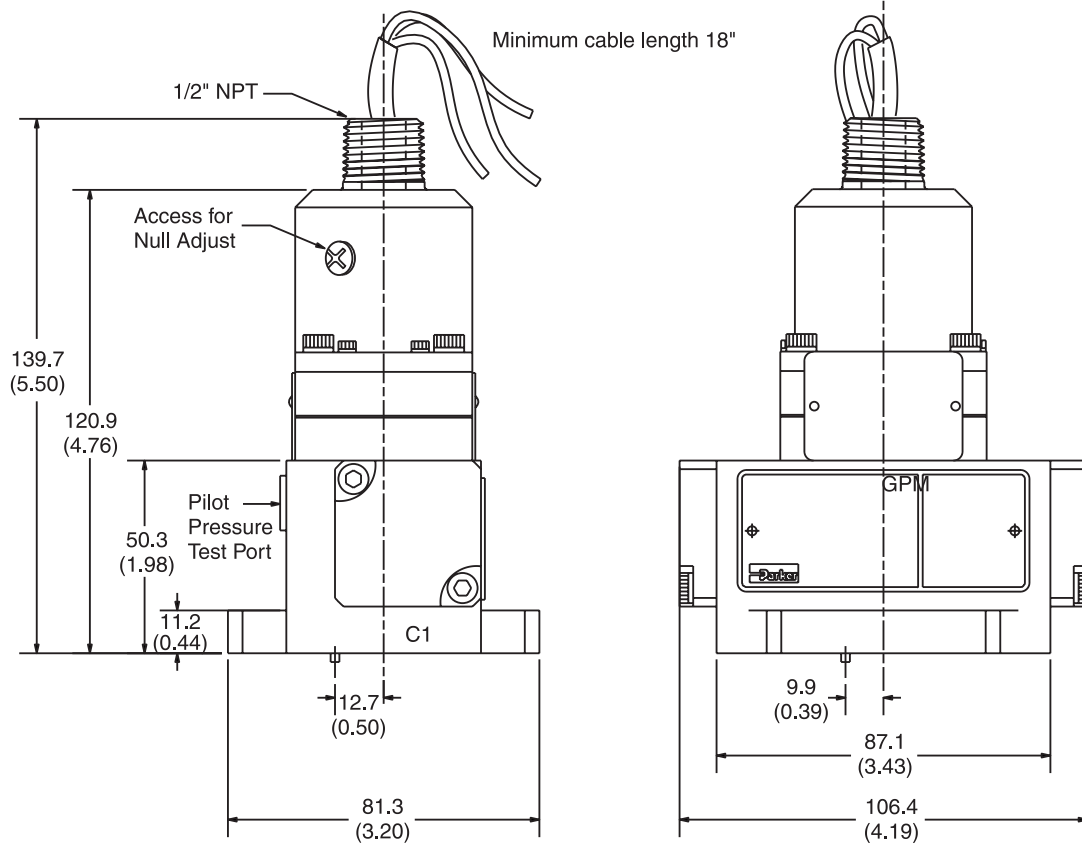

Note: Valve mating surface to be flat within 0.002 TIR, and smooth to within 63 RMS

Inch equivalents for millimeter dimensions are shown in (**)

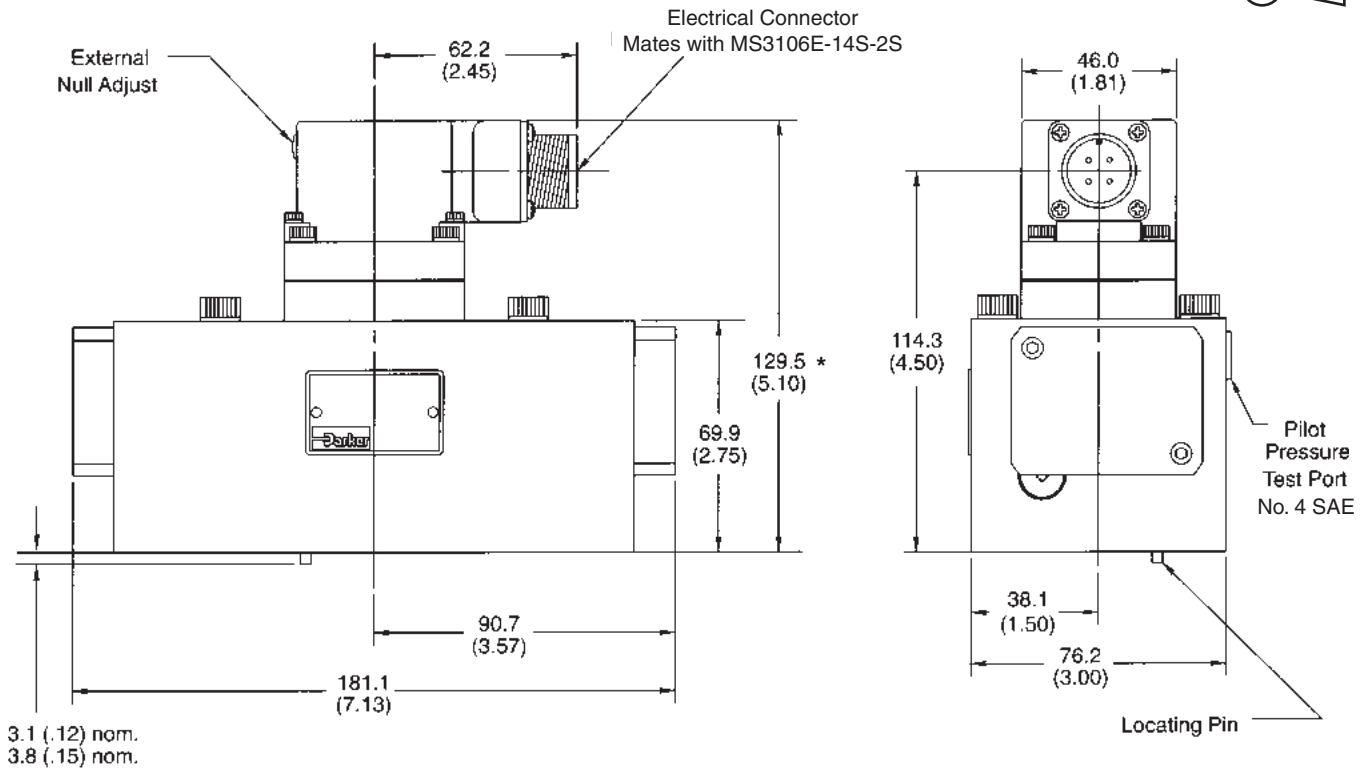

C

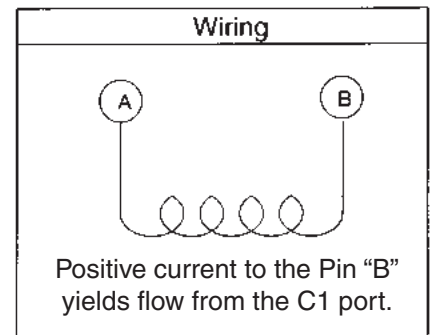
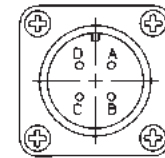
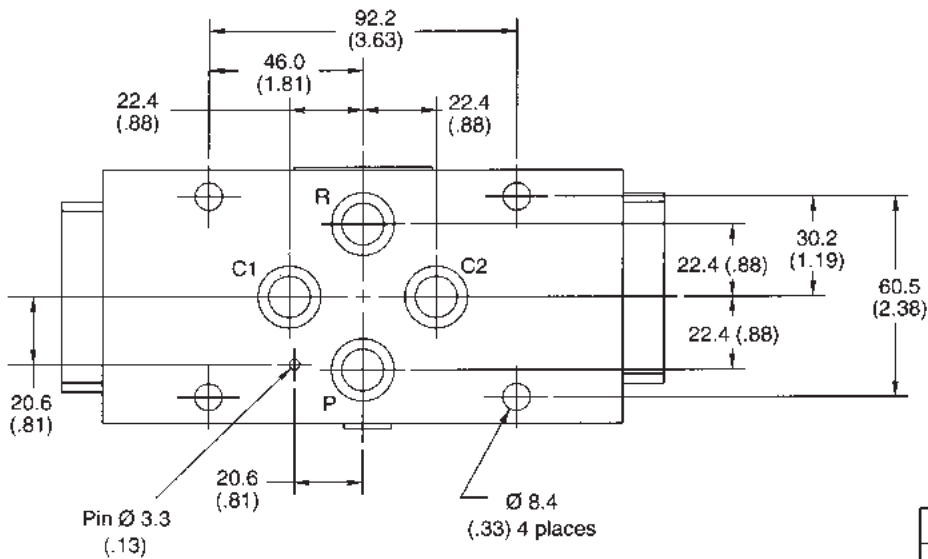

Note: Valve mating surface to be flat within 0.002 TIR, and smooth to within 63 RMS

* 160 (6.25) for BD30C; explosion proof, FM approved.
Note: Vertically oriented 1/2 NPT threaded male conduit connection with lead wires (not as shown).

Inch equivalents for millimeter dimensions are shown in (**)



C

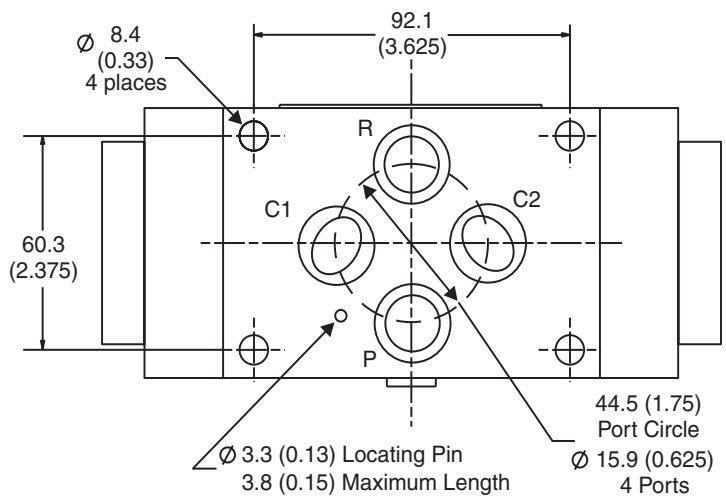
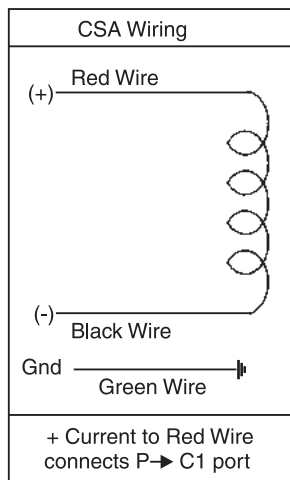
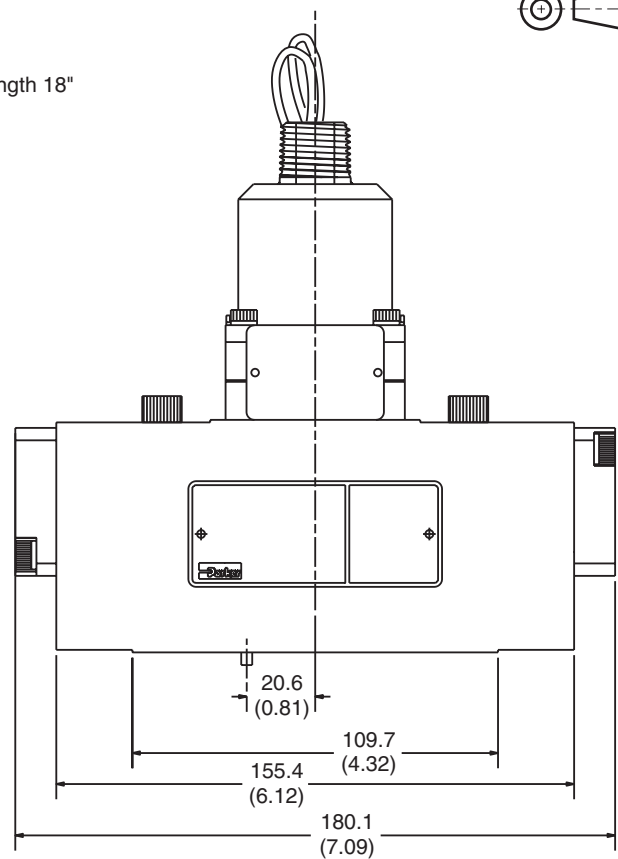
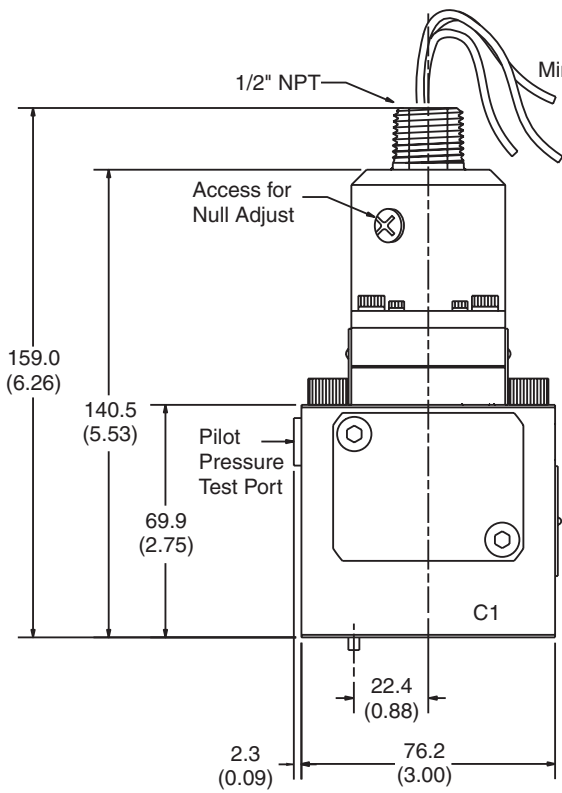

Note: Valve mating surface to be flat within 0.002 TIR, and smooth to within 63 RMS

Dimensions

Series BD30, ATEX Version BD30N*M

Inch equivalents for millimeter dimensions are shown in (**)

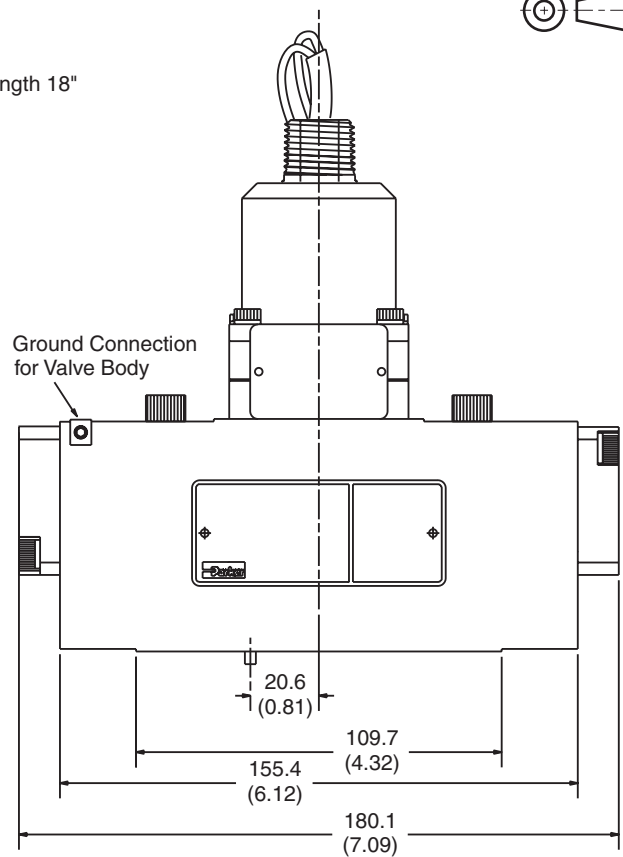
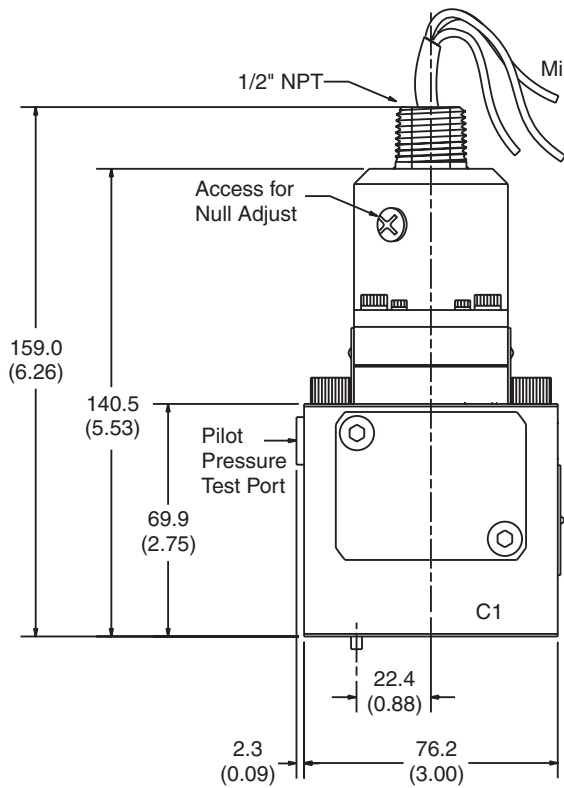

C

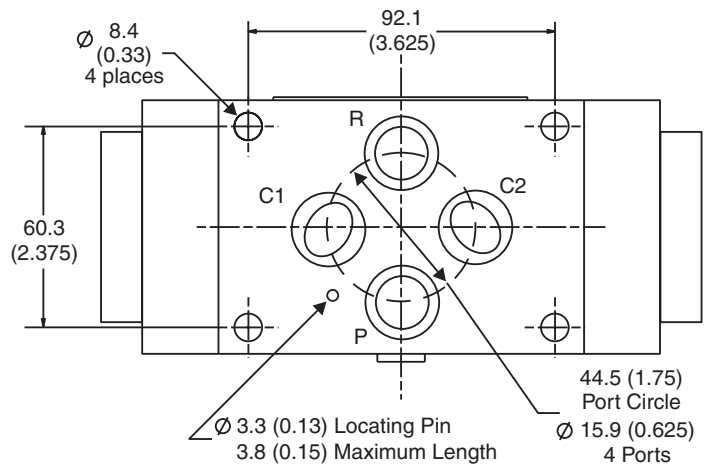
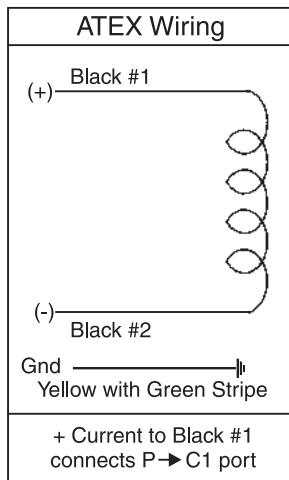

Note: Valve mating surface to be flat within 0.002 TIR, and smooth to within 63 RMS