

Characteristics

The NG06 directional control valve series D1VW provides high functional limits up to 80 l/min in combination with a very low, energy-saving pressure drop.

A wide variety of spool options allows to design an unlimited number of hydraulic circuits.

Versions with 8 watt coils, position control, ATEX approval, surface protection and connector variants are shown in the following chapters.

The valve is also available as sandwich type, see series Z1DW in chapter 7.

Valves with explosion proof solenoids Ex e mb II see series D1VW Explosion Proof in chapter 2 and catalogue MSG11-3343/UK.

Download of the PDF file at www.parker.com/ISDE, see "Support".

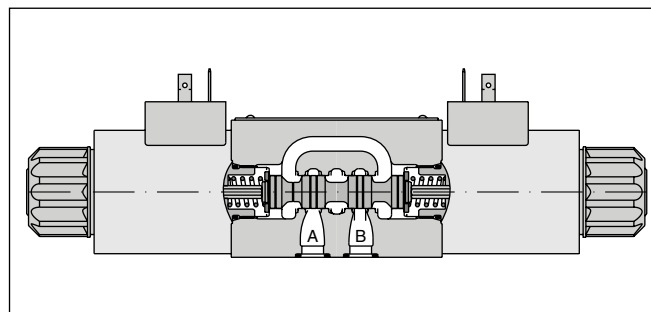
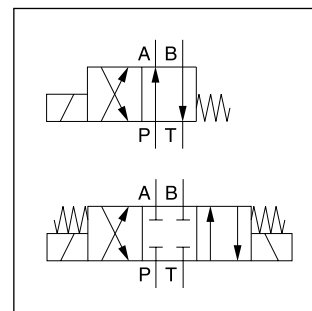

2

Technical data

General							
Design	Directional spool valve						
Actuation	Solenoid						
Nominal size	DIN NG06 / CETOP 03 / NFPA D03						
Mounting interface	DIN 24340 A6 / ISO 4401 / CETOP RP 121-H / NFPA D03						
Mounting position	unrestricted, preferably horizontal						
Ambient temperature	[°C] -25...+60						
MTTF _D value	[years] 150						
Weight	[kg] 1.5 (1 solenoid), 2.1 (2 solenoids)						
Vibration resistance	[g] 10 Sinus 5...2000 Hz acc. IEC 68-2-6 30 Random noise 20...2000 Hz acc. IEC 68-2-36 15 Shock acc. IEC 68-2-27						
Hydraulic							
Max. operating pressure	[bar] P, A, B: 350; T: 210 (DC), T: 140 (AC)						
Fluid	Hydraulic oil according to DIN 51524						
Fluid temperature	[°C] -20 ... +70 (NBR: -25...+70)						
Viscosity permitted	[cSt] / [mm ² /s] 2.8...400						
Viscosity recommended	[cSt] / [mm ² /s] 30...80						
Filtration	ISO 4406 (1999); 18/16/13						
Flow max.	[l/min] 80 (see shift limits)						
Leakage at 50 bar	[ml/min] Up to 10 per flow path, depending on spool, up to 15 per flow path for spool type 008 + 009						
Static / Dynamic							
Step response	see table response time						
Electrical characteristics							
Duty ratio	[%] 100 ED; CAUTION: coil temperature up to 150 °C possible						
Max. switching frequency	[1/h] 15000 (not for soft shift)						
Protection class	IP65 in accordance with EN 60529 (with correctly mounted plug-in connector)						
	Code	K	J	U	G	Y	T
Supply voltage	[V]	12 V =	24 V =	98 V =	205 V =	110 V at 50 Hz / 120 V at 60 Hz	230 V at 50 Hz / 240 V at 60 Hz
Tolerance supply voltage	[%]	±10	±10	±10	±10	±5	±5
Current consumption	hold [A]	2.72	1.29	0.33	0.13	0.6 / 0.55	0.3 / 0.27
Current consumption	in rush [A]	2.72	1.29	0.33	0.13	2.5 / 2.4	1.25 / 1.2
Power consumption	hold	32.7 W	31 W	31.9 W	28.2 W	70 / 70 VA	70 / 70 VA
Power consumption	in rush	32.7 W	31 W	31.9 W	28.2 W	280 / 290 VA	280 / 290 VA
Solenoid connection		Connector as per EN 175301-803, solenoid identification as per ISO 9461 (code W).					
Wiring min.	[mm ²]	3 x 1.5 recommended					
Wiring length max.	[m]	50 recommended					

With electrical connections the protective conductor (PE ≍) must be connected according to the relevant regulations.

2

D

Directional control valve

1

Size
 DIN NG06
 CETOP 03
 NFFPA D03

V

3-chamber valve

W

Wet pin armature solenoid, threaded in tube

Spool type

Spool position

3 position spools	
Code	Spool type
	a 0 b
001	
002	
003	
004	
005	
006	
007	
008 ¹⁾	
009 ¹⁾	
010	
011	
014	
015	
016	
021	
022	
031	
032	
034	
035	
061	
081	
082	
102	
204 ¹⁾	
205 ¹⁾	

2 position spools	
Code	Spool type
	a b
020	
026	
030	
083 ¹⁾	
101	
208	

3 position spools			
Code	Spool position		
C			3 positions. Spring offset in position "0". Operated in position "a" or "b".
	Standard	Spool type 008,009, 204, 205	
E			2 positions. Spring offset in position "0".
	Operated in position "a".	Operated in position "b".	
F			2 positions. Operated in position "0".
	Spring offset in position "b".	Spring offset in position "a".	
K			2 positions. Spring offset in position "0".
	Operated in position "b".	Operated in position "a".	
M			2 positions. Operated in position "0".
	Spring offset in position "a".	Spring offset in position "b".	

2 position spools			
Code	Spool position		
	Standard	Spool type 083	
B			2 positions. Spring offset in position "b". Operated in position "a".
D			2 positions. Operated in position "a" or "b". No center or offset position.
H			2 positions. Spring offset in position "a". Operated in position "b".

¹⁾ Consider specific spool position.
²⁾ To be used in combination with rectifier plugs at 120 VAC / 230 VAC power supply.
³⁾ DC only

Ordering Code

2



Seals



Solenoid voltage



Solenoid connector as per EN 175301-803, **without plug** (other connectors are available for D1MW Series)



Solenoid option



Design series (not required for ordering)

Code	Solenoid option
omit	manual override (standard)
T	without manual override
S2 ³⁾	Soft shift orifice size 0.5 mm.
S3 ³⁾	Soft shift orifice size 0.75 mm.
4N ³⁾	with lockable manual override

Code	Voltage
K	12 V =
J	24 V =
U ²⁾	98 V =
G ²⁾	205 V =
Y	110 V 50 Hz / 120 V 60 Hz
T	230 V 50 Hz / 240 V 60 Hz

Code	Seals
N	NBR
V	FPM

Bold letters =
Short-term availability

Further spool types, solenoid voltages and connectors on request.

Flow curve

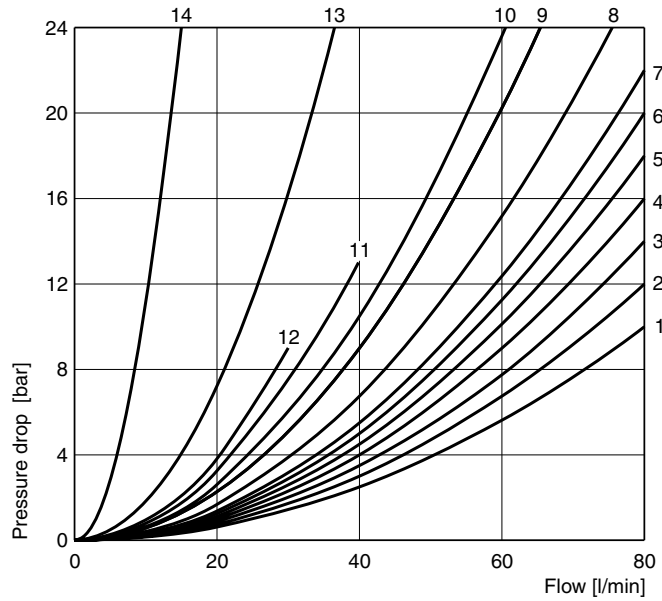

All characteristic curves measured with HLP46 at 50 °C.

Spool	Position "b"			Position "a"			Position "0"				
	P-A	B-T	P-B	P-B	A-T	P-A	P-A	P-B	A-T	B-T	P-T
001	2	2		2	2						
002	1	4		1	4		1	1	5	5	2
003	3	4		3	6				7		
004	2	3		2	3				7	7	
005	2	2		2	2						
006	1	4		1	4		12	7			
007	3	2		2	2			3		2	7
010	3			3							
011	2	2		2	2				14	14	
014	3	2		2	2		3		2		7
015	3	6		3	4					7	
016	2	2		2	2			12			
020B	4	4		2	3						
026B	4			4							
030B	2	3		1	2						
034	4		8	3	3				5	7	
035	3	3		4		8			7	5	
081	13	13		13	13						
082	13	13		13	13				1)	1)	
101B	11	10		10	9						
102	1	4		1	4		5	5	8	8	6
61	1	3		1	3		3	2			
83H	5	2		5	2						
208	3			2							
	P-B	A-T		P-A	B-T		P-A	P-B	A-T	B-T	P-T
008	4	5		4	5						9
009	5	5		6	7						7
83B	5	2		5	2						
204	1	3		4	3		7		4		7
205	4	3		1	3			7		4	5

Spool	Position "b"			Position "a"		
	P-A	P-B	A-B	P-B	A-T	
021	2	4		4	2	
	P-A	B-T		P-A	P-B	A-B
022	6	2		5	2	

1) Only for pressure compensation, no high flow possible.

The diagram below specifies the shift limits for valves with DC & AC solenoids. Valves with spool position “F” or “M” can only be operated up to 70 % of the limits. The specifications apply to a viscosity of 40 mm²/s and

balanced flow conditions. The shift limits can be considerably lower at unbalanced flow conditions. To avoid flow rates beyond the shift limits, a plug-in orifice can be inserted in the P-port.

Valve with standard DC solenoid

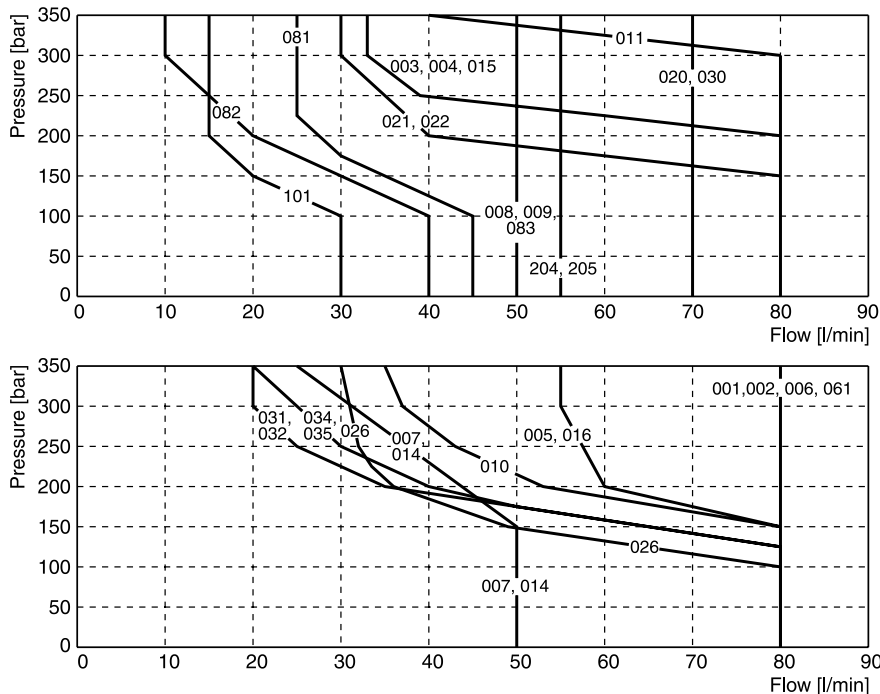

Measured with HLP46 at 50 °C, 90 % U_{nom} and warm solenoids

Valve with standard AC solenoid

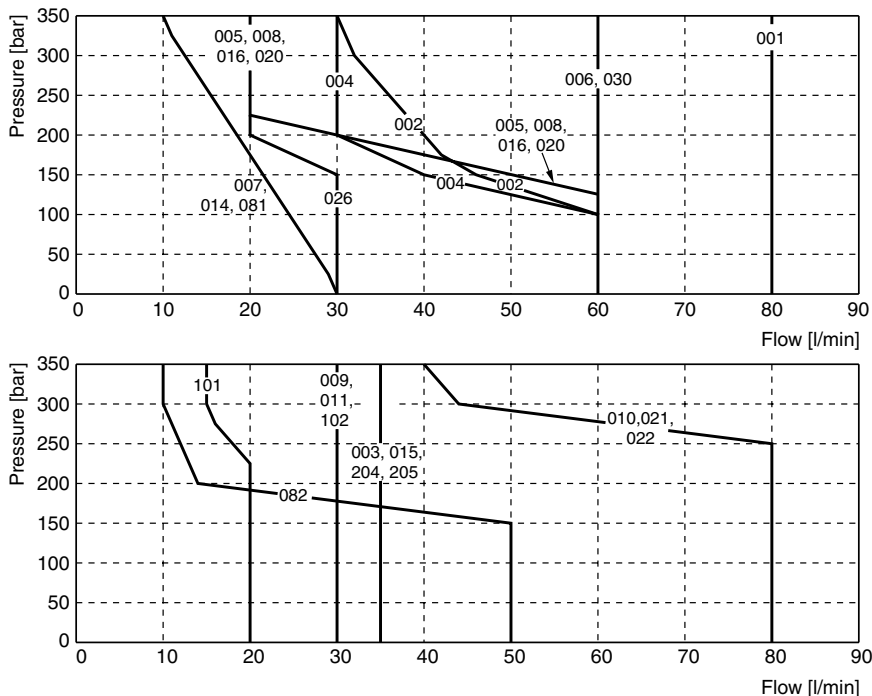

Measured with HLP46 at 50 °C, 95 % U_{nom} and warm solenoids

Shift Limits / Response Times

Shift limit diagram - Soft shift with 1 DC solenoid

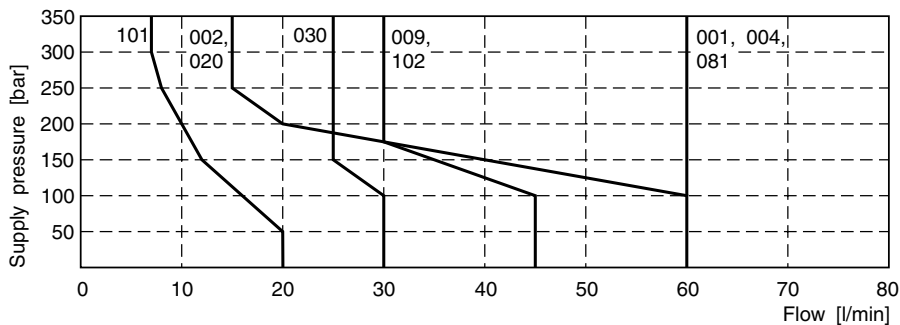

Shift limit diagram - Soft shift with 2 DC solenoids

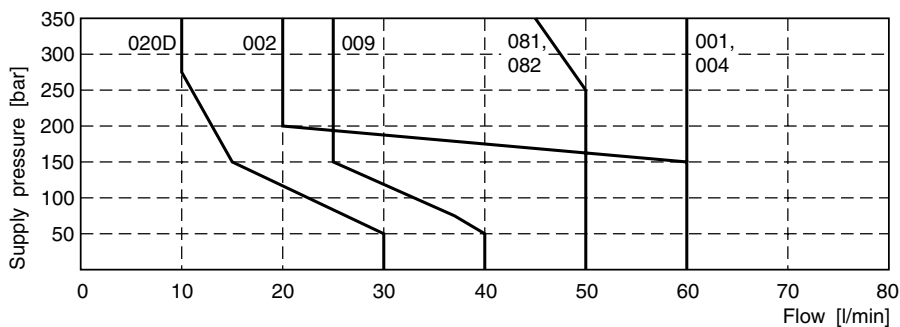

Measured with HLP46 at 50 °C, 90 % U_{nom} and warm solenoids.

Response times D1VW Standard and Soft Shift [ms]

Standard solenoid	Orifice	Energize	De-energize
Standard DC	w/o	45 - 60	20 - 30
Standard AC	w/o	13	20
Standard DC with rectifier plug	w/o	60 - 70	70 - 90

Response times soft shift		2 solenoid valve 3 positions		2 solenoid valve 3 positions		1 solenoid valve 2 positions	
Code	Orifice size	Center position: Closed		Center position: Open		Energize	De-energize
		Energize	De-energize	Energize	De-energize		
S2	0.50 mm	200 - 750	310 - 650	220 - 400	350 - 750	90 - 350	160 - 500
S3	0.75 mm	180 - 300	300 - 400	200 - 350	300 - 500	90 - 350	130 - 350

The lower value applies to small flow rates and low pressure, the upper value to high flow rates and high pressure.

Step response times were obtained under the following conditions: HLP46 at 50 °C with the valve operating at nominal pressure and flow. Published response times are nominal and may vary with spool, flow, pressure and temperature.

Acceleration for orifice size 0.75, code "S3" (measured against a standard valve)

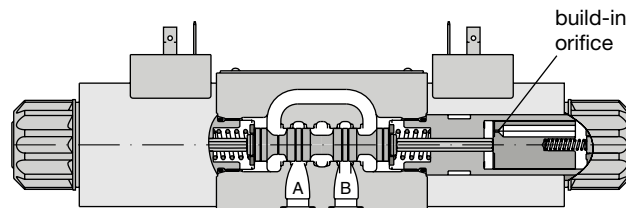
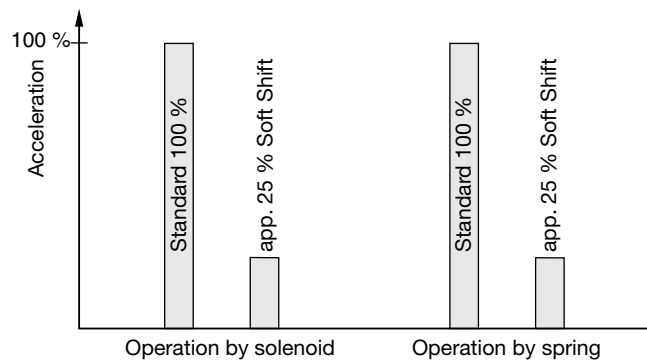

For even softer shifting, the proportional spools 081, 082, 101 and 102 can be used.

Dimensions

**Directional Control Valve
Series D1VW**

2

**Interface EN 175301-803, DC solenoid
B, E, F -style**

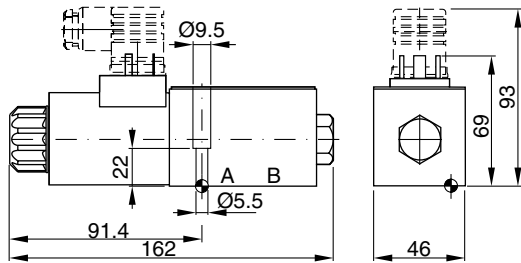

H, K, M -style

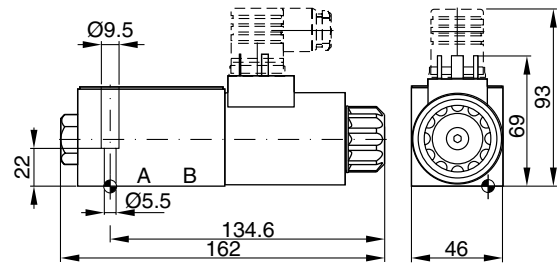

C, D -style

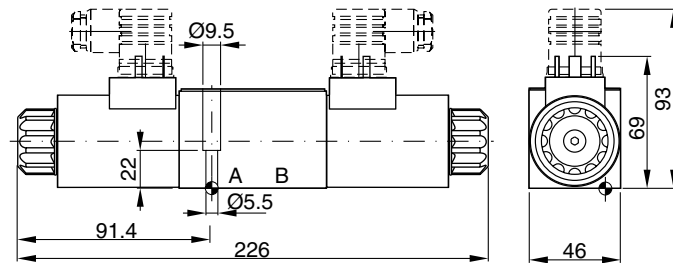

**Option 4N, with lockable manual override
(available for all styles, DC only)**

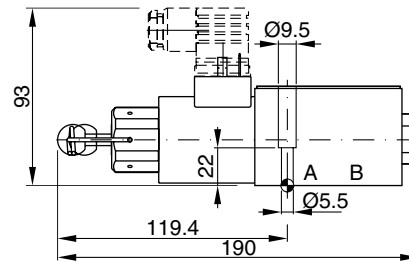

**Interface EN 175301-803, AC solenoid
B, E, F -style**

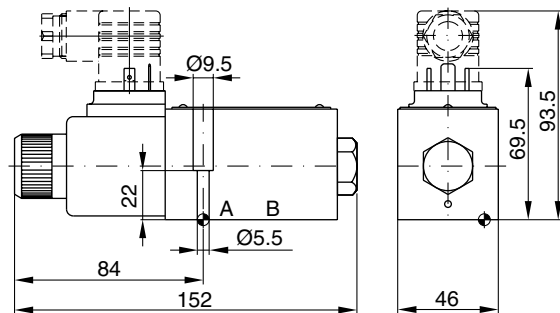



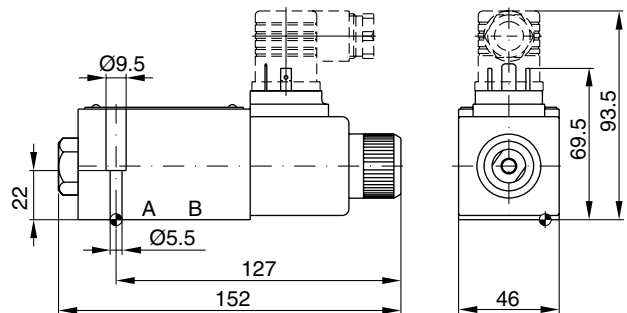

H, K, M -style

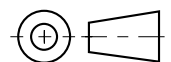
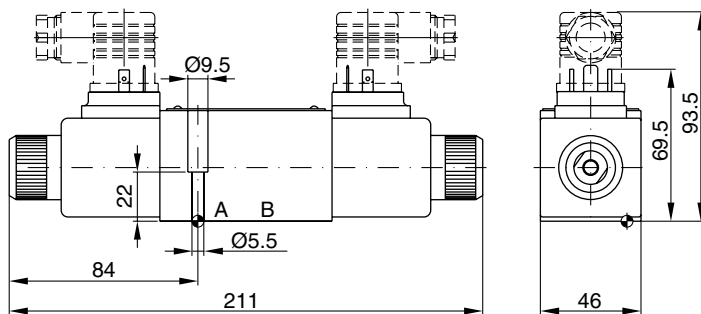

C, D -style

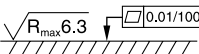

Surface finish	 Kit	 Kit	 Kit	 Kit
$\sqrt{R_{max} 6.3}$ 	BK375	4x M5x30 ISO 4762-12.9	7.6 Nm ±15 %	NBR: SK-D1VW-N-91 FPM: SK-D1VW-V-91

The space necessary to remove the plug per EN 175301-803, design type AF is at least 15 mm.
The torque for the screw M3 of the plug has to be 0.5 to 0.6 Nm.

Characteristics

The D1VW 8 Watt series is based on the standard D1VW design. The low watt, low current (<0.5 A) solenoid allows direct connection to a PLC or a bus knot. The valves are offered with standard solenoid connection (as per EN175301-803) and M12 x 1 connection. The version with M12 x 1 connection and LEDs is conform to the DESINA standard (**D**istribut**E**d and **S**tandardised **I**Nst**A**l-lation technology) for machine tools and manufacturing systems.

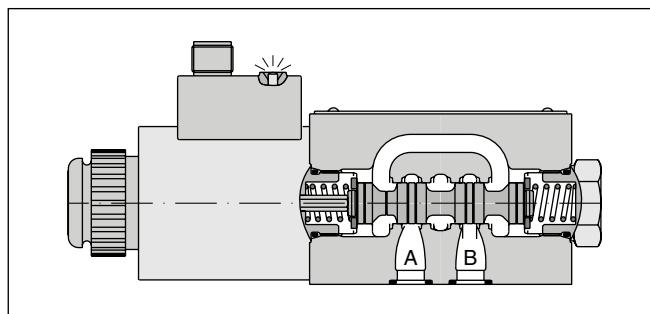
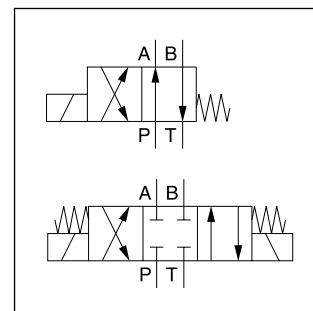

2

Technical data

General		
Design		Directional spool valve
Actuation		Solenoid
Size		DIN NG06 / CETOP 03 / NFPA D03
Mounting interface		DIN 24340 A6 / ISO 4401 / CETOP RP 121-H / NFPA D03
Mounting position		unrestricted, preferably horizontal
Ambient temperature	[°C]	-25...+60
MTTF _D value	[years]	150
Weight	[kg]	1.5 (1 solenoid), 2.1 (2 solenoids)
Vibration resistance	[g]	10 Sinus 5...2000 Hz acc. IEC 68-2-6 30 Random noise 20...2000 Hz acc. IEC 68-2-36 15 Shock acc. IEC 68-2-27
Hydraulic		
Max. operating pressure	[bar]	P, A B: 350, T: 210
Fluid		Hydraulic oil according to DIN 51524
Fluid temperature	[°C]	-20 ... +70 (NBR: -25...+70)
Viscosity permitted	[cSt] [mm ² /s]	2.8...400
Viscosity recommended	[cSt] [mm ² /s]	30...80
Filtration		ISO 4406 (1999); 18/16/13
Flow max.	[l/min]	60 (see shift limits)
Leakage at 50 bar	[ml/min]	Up to 10 per flow path, depending on spool
Static / Dynamic		
Step response at 95 %	[ms]	Energized: 80...120; De-energized: 35...55
Electrical characteristics		
Duty ratio		100 % ED; CAUTION: coil temperature up to 70 °C possible
Max. switching frequency	[1/h]	10000
Protection class		IP65 in acc. with EN 60529, M12x1 IP67 (each with correctly mounted plug-in connector)
Code		J
Supply voltage	[V]	24 V =
Tolerance supply voltage	[%]	±10
Current consumption	[A]	0.33
Power consumption	[W]	8
Solenoid connection		Connector as per EN 175301-803, solenoid identification as per ISO 9461 (code W). Plug M12x1 on coil as per IEC 61076-2-101 (code D).
Wiring min.	[mm ²]	3 x 1.5 recommended
Wiring length max.	[m]	50 recommended

With electrical connections the protective conductor (PE ≍) must be connected according to the relevant regulations.

D

Directional control valve

1

Size
 DIN NG06
 CETOP 03
 NFPA D03

V

3-chamber valve

W

Wet pin solenoid

Spool type

Spool position

2

3 position spools	
Code	Spool type
	a 0 b
001	
002	
003	
004	
005	
006	
007	
008 ¹⁾	
009 ¹⁾	
010	
011	
014	
015	
016	
081	
082	
102	

2 position spools	
Code	Spool type
	a b
020	
026	
030	
101	

3 position spools		
Code	Spool position	
C		3 positions. Spring offset in position "0". Operated in position "a" or "b".
	Standard	Spool type 008, 009
E		2 positions. Spring offset in position "0".
	Operated in position "a".	Operated in position "b".
K		2 positions. Spring offset in position "0".
	Operated in position "b".	Operated in position "a".

2 position spools		
Code	Spool position	
B		2 positions. Spring offset in position "b". Operated in position "a".
D ²⁾		2 positions. Operated in position "a" or "b". No center or offset position.
H		2 positions. Spring offset in position "a". Operated in position "b".

¹⁾ Consider specific spool position.

²⁾ Only for spool 020 available.

³⁾ Please order plug separately.

Ordering Code

2

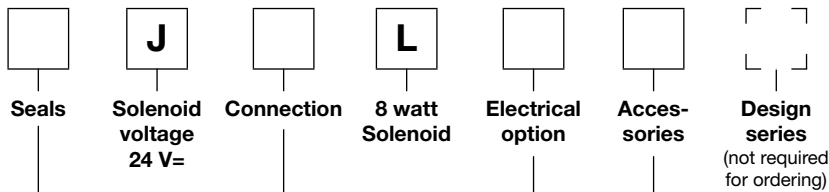

Code	Accessories
	Standard valve (in combination with solenoid connection "D" and "W")
5	Always in combination with electrical option „J“

Solenoid identification acc. to ISO 9461

Code	Electrical option
	M12 connector in combination with solenoid connection "D" and "W", see „Pin Assignment“
J	M12 connector in combination with solenoid connection "D", see "Pin Assignment"

Code	Connection
D ³⁾	Connector M12x1 as per IEC 61076-2-101
W³⁾	Connector as per EN 175301-803

Code	Seals
N	NBR
V	FPM

Bold letters = Short-term availability

Further spool types on request.
To get a DESINA valve, order the combination: JDLJ5.

The flow curve diagram shows the flow versus pressure drop curves for all spool types. The relevant curve

number for each spool type, operating position and flow direction is given in the table below.

2

Spool	Position „b“		Position „a“		Position „0“				
	P->A	B->T	P->B	A->T	P->A	P->B	A->T	B->T	P->T
001	3	3	3	3	-	-	-	-	-
002	3	4	3	4	1	1	3	3	1
003	4	4	4	5	-	-	4	-	-
004	3	4	3	4	-	-	4	4	-
005	3	3	3	3	8 (max. 30l)	-	-	-	-
006	3	4	3	4	4	4	-	-	-
007	4	3	3	3	-	2	-	1	4
010	4	-	4	-	-	-	-	-	-
011	3	3	3	3	-	-	11 (max. 25l)	11 (max. 25l)	-
014	4	3	3	3	2	-	1	-	4
015	4	5	4	4	-	-	-	4	-
016	3	3	3	3	-	8 (max. 30l)	-	-	-
020B	4	4	3	4	-	-	-	-	-
026B	4	-	4	-	-	-	-	-	-
030B	3	4	4	3	-	-	-	-	-
081	9	10	9	10	-	-	-	-	-
082	9	10	9	10	-	-	-	-	-
101B	4 (max. 40l)	7	7	6	-	-	-	-	-
102	3	4	3	4	3	3	5	5	3
	P->B	A->T	P->A	B->T	P->A	P->B	A->T	B->T	P->T
008	4	5	4	5	-	-	-	-	6
009	5	5	5	5	-	-	-	-	4

Flow curve diagram

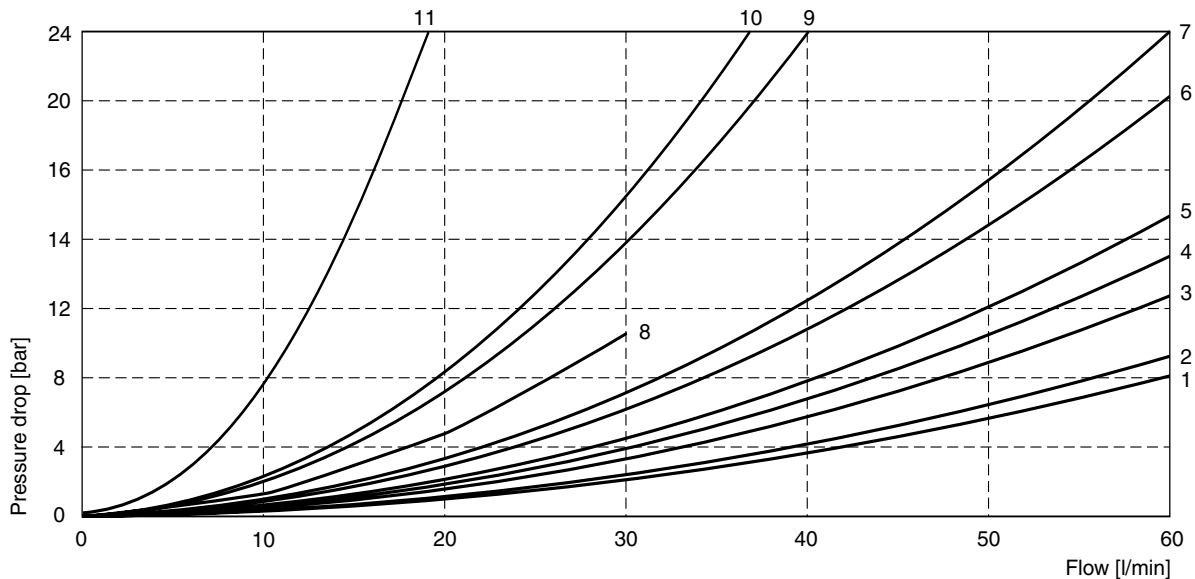

All characteristic curves measured with HLP46 at 50 °C.

The diagram below specifies the shift limits. The specifications apply to a viscosity of 40 mm²/s and balanced flow conditions. The shift limits can be considerably

lower at unbalanced flow conditions. To avoid flow rates beyond the shift limits, a plug-in orifice can be inserted in the P-port.

Shift limits

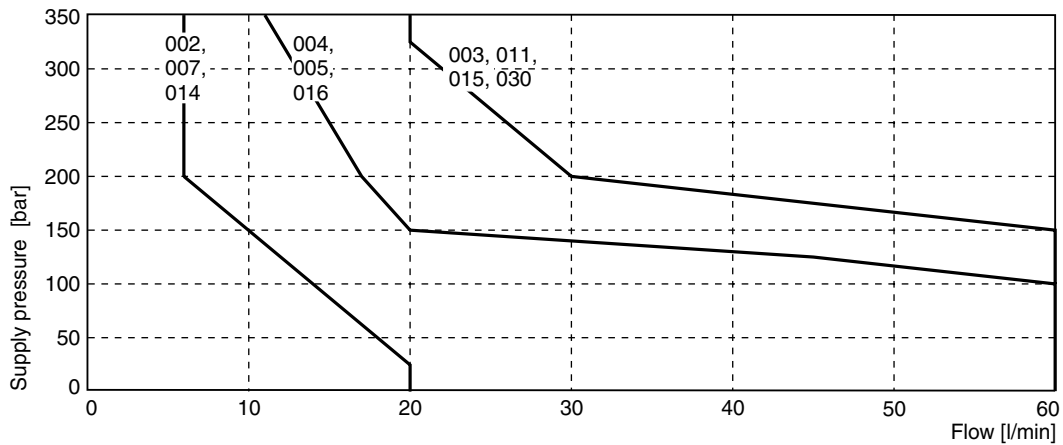
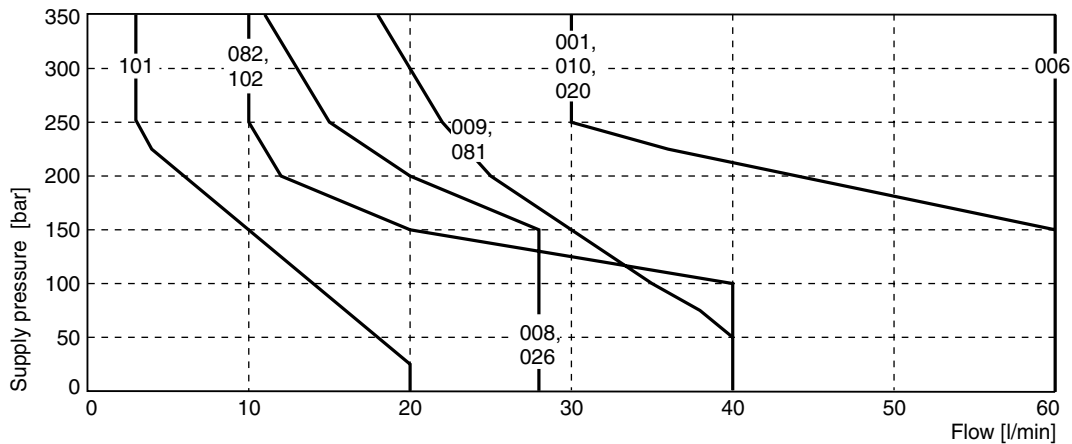

Measured with HLP46 at 50 °C, 90 % U_{nom} and warm solenoids.

M12 pin assignment DESINA design, code „JDLJ5“, pins 1 and 2 connected ¹⁾

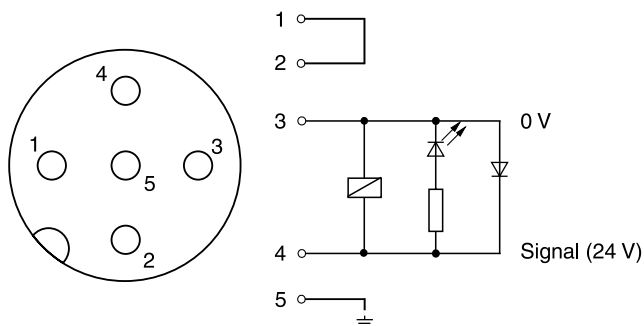

M12 pin assignment, code “JDL“, pins 1 and 2 not connected ¹⁾

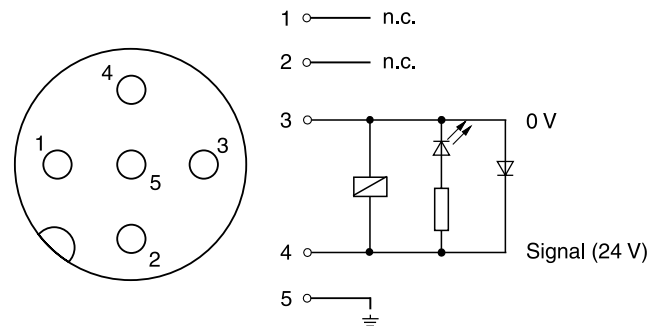

¹⁾ Surge diode with LED, max. voltage peak 50 V

Dimensions

Interface EN 175301-803, DC solenoid, JWL
Style B, E

Style H, K

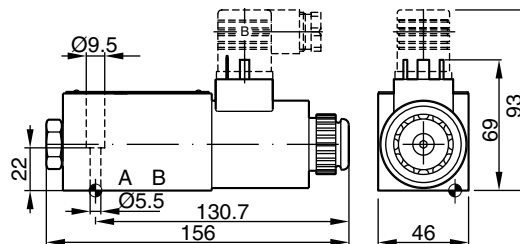
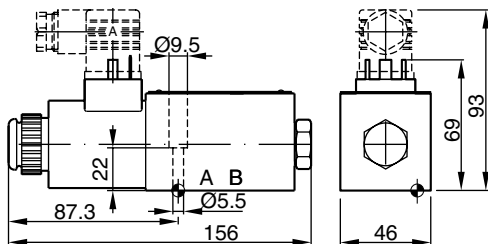

Style C, D

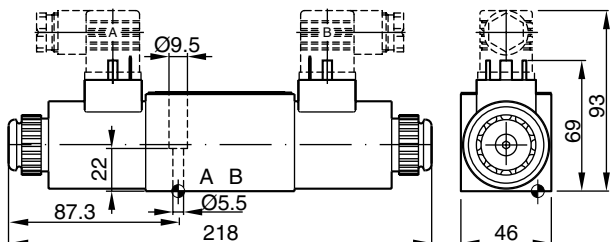

M12x1 connector, DC solenoid, JDLJ5 (DESINA) or JDL
Style B, E

Style H, K

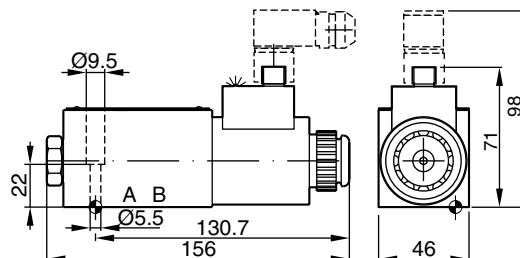
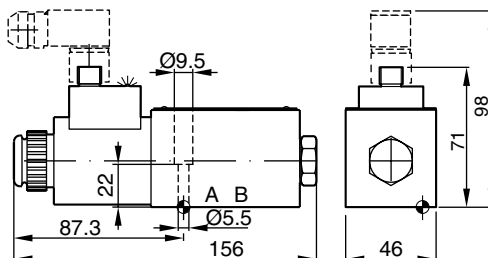

Style C, D

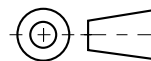
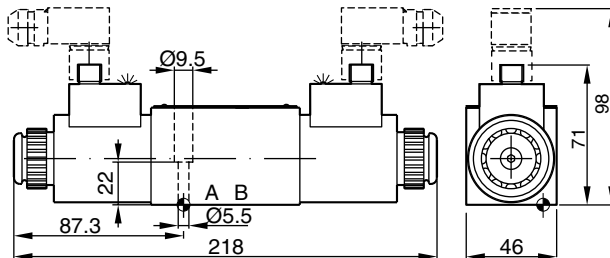

Surface finish	Kit	Kit	Kit	Kit
$\sqrt{R_{max}6.3}$ $\square_{0.01/100}$	BK375	4x M5x30 ISO 4762-12.9	7.6 Nm ±15 %	NBR: SK-D1VW-N-91 FPM: SK-D1VW-V-91

The space necessary to remove the plug per EN 175301-803, design type AF is at least 15 mm.
The torque for the screw M3 of the plug has to be 0.5 to 0.6 Nm.

The direct operated directional valves series D1VW with inductive position control are typically used in safety relevant applications. The start or end position can be monitored. The position control is available for single and double solenoid valves.

The fail-safe position of the directional valve during power failure is the spring offset or center position.

Please find detailed information on the machine directive in the position paper in chapter 1.

Attention:

The adjustment of the position control is factory set and sealed. Replacement and repairs can only be undertaken by the manufacturer.

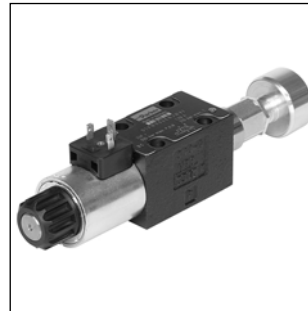

D1VW*B



D1VW*C

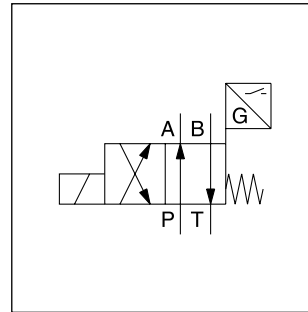

D1VW*B

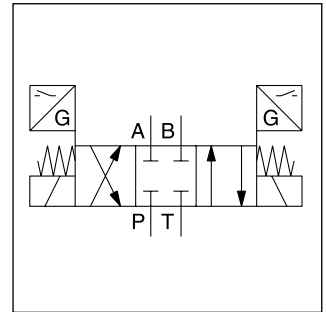

D1VW*C

D1VW*B

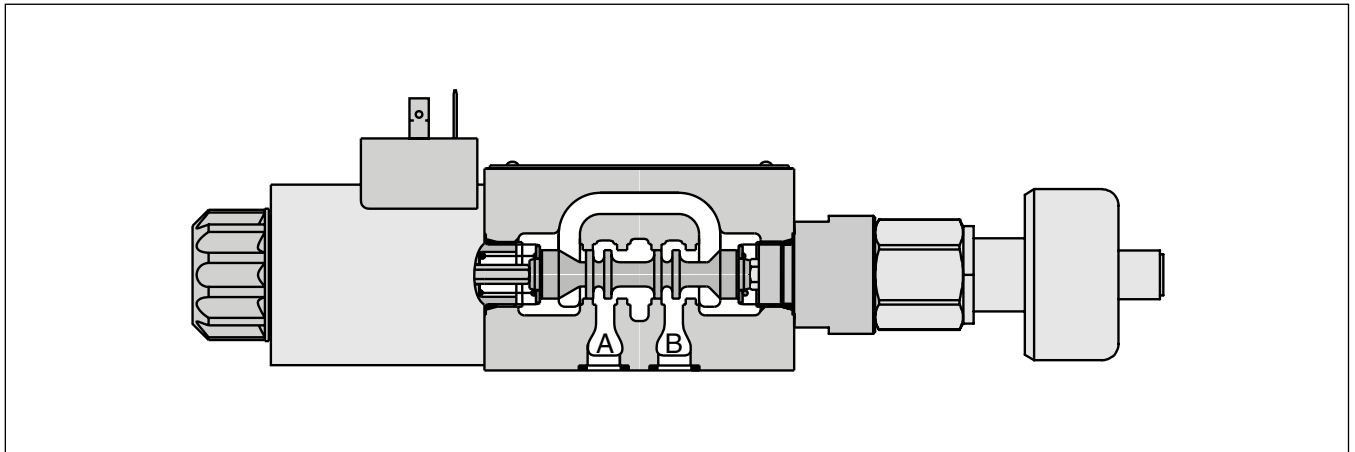

D1VW*C

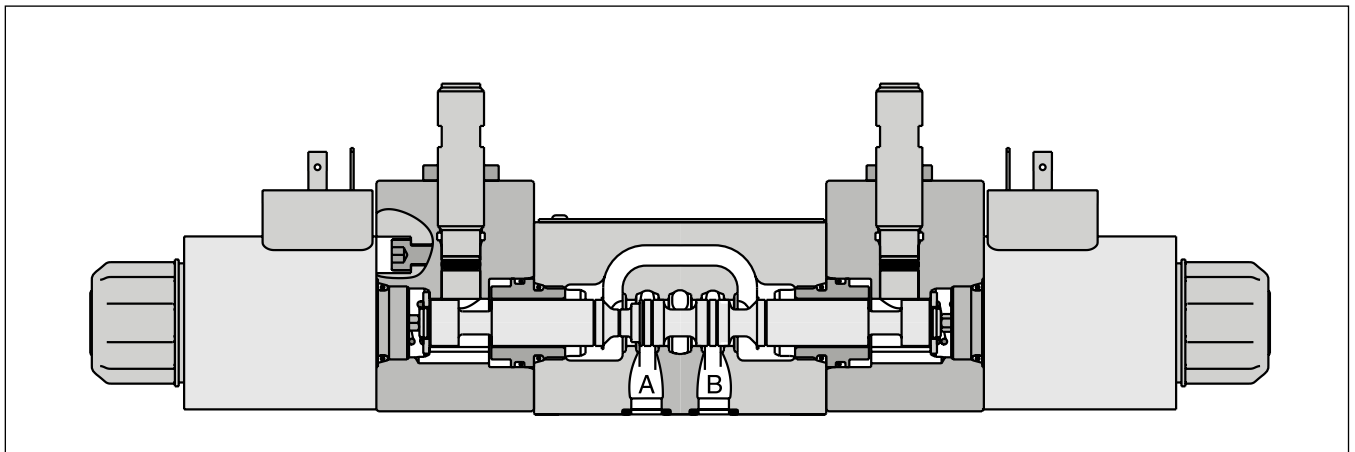

2

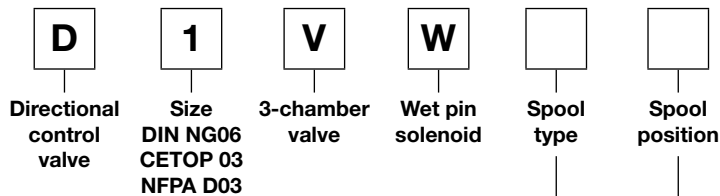

3 position spools	
Code	Spool type
	a 0 b
001	
002	
003 ¹⁾	
004	
005	
015 ²⁾	
016	
076	
078	

2 position spools	
Code	Spool type
	a b
020	
026 ³⁾	
030 ³⁾	

3 position spools		
Code	Spool position	
E	 Operated in position "a".	2 positions. Spring offset in position "0".
F	 Spring offset in position "b".	2 positions. Operated in position "0".
K	 Operated in position "b".	2 positions. Spring offset in position "0".
M	 Spring offset in position "a".	2 positions. Operated in position "0".

2 position spools		
Code	Spool position	
B	 Spring offset in position "b".	2 positions. Spring offset in position "b". Operated in position "a".
H	 Spring offset in position "a".	2 positions. Spring offset in position "a". Operated in position "b".

¹⁾ Only available for spool position "E" and "F".

²⁾ Only available for spool position "K" and "M".

³⁾ Only available for spool position "B" and "H".

⁴⁾ To be used in combination with rectifier plugs at 120 VAC / 230 VAC power supply.

⁵⁾ Please order female connector M12x1 separately (see accessories, female connector M12x1 (order no.: 5004109).

⁶⁾ For hydraulic presses according to the safety regulations DIN EN ISO 16092-3, solenoid option "T" (without manual override) and accessory "I4N" or "I5N" (start position monitored) are required.



Seals



Solenoid voltage



W
Connector as per EN 175301-803, without plug (please order plug separately)



Manual override option



Position control ⁵⁾



Design series (not required for ordering)

Code	Position control	Spool position
I2N	End position monitored side B	E, F, B (Solenoid on a-side)
I5N⁶⁾	Start position monitored side B	
I1N	End position monitored side A	K, M, H (Solenoid on b-side)
I4N⁶⁾	Start position monitored side A	

Code	Manual override
omit	manual override (Standard)
T ⁶⁾	without manual override

Code	Voltage
K	12 V=
J	24 V=
U ⁴⁾	98 V=
G ⁴⁾	205 V=

Code	Seals
N	NBR
V	FPM

Bold letters = Short-term availability

Further spool types and voltages on request.

2

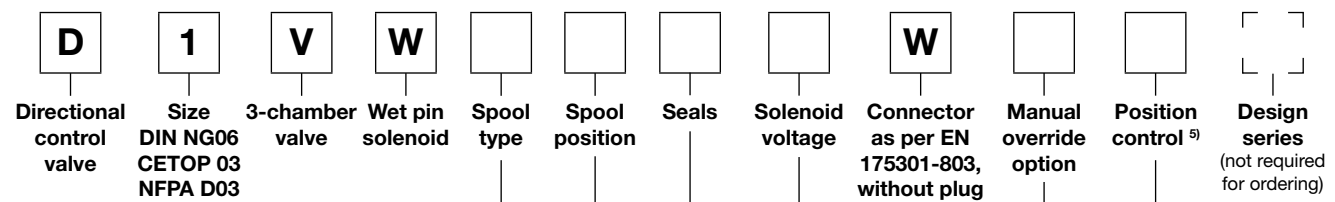

D
Directional control valve

1
Size
DIN NG06
CETOP 03
NFFPA D03

V
3-chamber valve

W
Wet pin solenoid

Spool type

Spool position

Seals

Solenoid voltage

W
Connector as per EN 175301-803, without plug (please order plug separately)

Manual override option

Position control⁵⁾

Design series (not required for ordering)

3 position spools	
Code	Spool type
	a 0 b
001	
002	
003 ¹⁾	
004	
015 ¹⁾	

2 position spools	
Code	Spool type
	a b
020	

3 position spools	
Code	Spool position
C	 3 positions. Spring offset in position "0". Operated in position "a" or "b".

2 position spools	
Code	Spool position
D ²⁾	 2 positions. Operated in position "a" or "b". No center or offset position.

Code	Position control	Spool position
I3N	End positions	C, D
I6N ⁴⁾	Start positions	C

Code	Manual override
omit	manual override (Standard)
T ⁴⁾	without manual override

Code	Voltage
K	12 V=
J	24 V=
U ³⁾	98 V=
G ³⁾	205 V=

Code	Seals
N	NBR
V	FPM

Further spool types and voltages on request.

- ¹⁾ Only for position control code "I6N".
- ²⁾ Only for position control code "I3N".
- ³⁾ To be used in combination with rectifier plugs at 120 VAC / 230 VAC power supply.
- ⁴⁾ For hydraulic presses according to the safety regulations DIN EN ISO 16092-3, solenoid option "T" (without manual override) and accessory "I6N" (start positions) is required.
- ⁵⁾ Please order plug M12 x 1 separately. Straight plug recommended – no defined position possible for angled plug.

General					
Design	Directional spool valve				
Actuation	Solenoid				
Size	DIN NG06 / CETOP 03 / NFPA D03				
Mounting interface	DIN 24340 A6 / ISO 4401 / CETOP RP 121-H / NFPA D03				
Mounting position	unrestricted, preferably horizontal				
Ambient temperature	[°C] -20...+60				
MTTF _D value	[years] 150				
Weight	[kg] 1.8 (1 solenoid) / 3.8 (2 solenoids)				
Hydraulic					
Max. operating pressure	[bar] P, A B: 350 ; T: 210				
Fluid	Hydraulic oil according to DIN 51524				
Fluid temperature	[°C] -20 ... +70				
Viscosity permitted	[cSt] [mm ² /s] 2.8...400				
Viscosity recommended	[cSt] [mm ² /s] 30...80				
Filtration	ISO 4406 (1999); 18/16/13				
Flow max.	[l/min] 80 (see shift limits)				
Leakage at 50 bar	[ml/min] Up to 10 per flow path, depending on spool				
Static / Dynamic					
Step response at 95 %	[ms] Energized: 32 ; De-energized: 40				
Electrical characteristics					
Duty ratio	100 % ED; CAUTION: coil temperature up to 150 °C possible				
Max. switching frequency	[1/h] 15000				
Protection class	IP65 in accordance with EN 60529 (with correctly mounted plug-in connector)				
	Code	K	J	U	G
Supply voltage	[V]	12 V =	24 V =	98 V =	205 V =
Tolerance supply voltage	[%]	±10	±10	±10	±10
Current consumption	[A]	2.72	1.29	0.33	0.13
Power consumption	[W]	32.7	31	31.9	28.2
Solenoid connection		Connector as per EN 175301-803, solenoid identification as per ISO 9461.			
Wiring min.	[mm ²]	3 x 1.5 recommended			
Wiring length max.	[m]	50 recommended			

With electrical connections the protective conductor (PE \perp) must be connected according to the relevant regulations.

Position Control

Single solenoid valves

Electrical characteristics of position control as per IEC 61076-2-101 (M12x1)

Supply voltage	[VDC]	24
Tolerance supply voltage	[%]	±20
Ripple supply voltage	[%]	≤10
Polarity protection	[V]	300
Current consumption without load	[mA]	≤20
Switching hysteresis	[mm]	<0.06
Max. output current per channel, ohmic	[mA]	250
Ambient temperature	[°C]	-20 ... +60
Protection		IP65 acc. EN 60529 (with correctly mounted plug-in connector)
Min. distance to next AC solenoid	[m]	0.1
Interface		M12x1 to IEC 61076-2-101
CE conform		EN 61000-4-2 / EN 61000-4-4 / EN 61000-4-6 ¹⁾ / ENV 50140 / ENV 50204

2

M12 pin assignment

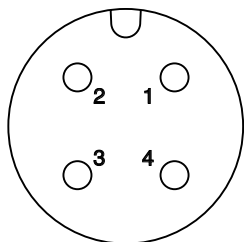

- 1 + U_s 19.2...28.8 V
- 2 Out B: normally open
- 3 0V
- 4 Out A: normally closed

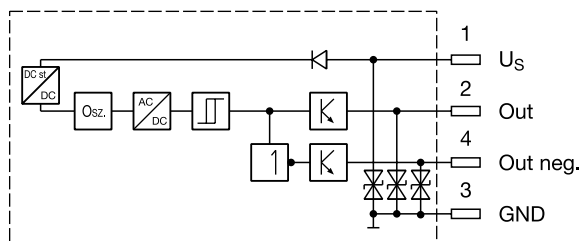

Outputs: Open collector

Definitions

Start position monitored:

The valve is de-energized. The inductive switch gives a signal at the moment when the spool leaves the spring offset position (below 15 % spool stroke).

At the switching point the spool is located within the closed position. It is secured that only the flow paths of the offset position are granted.

End position monitored:

The inductive switch gives a signal before the end position is reached (above 85 % spool stroke).

The switch can only be located on the opposite side of the solenoid for direct operated valves. Please order plug M12x1 separately (see accessories, plug M12x1; order no.: 5004109).

¹⁾ Only guaranteed with screened cable and female connector

Double solenoid valves

Electrical characteristics of position control as per IEC 61076-2-101 (M12x1)

Protection class		IP65 in accordance with EN 60529 (with correctly mounted plug-in connector)
Ambient temperature	[°C]	-20...+60
Supply voltage U_s / ripple	[V]	10...30 / ± 10 %
Current consumption without load	[mA]	≤ 10
Max. output current per channel, ohmic	[mA]	200
Min. output load per channel, ohmic	[kOhm]	100
Max. output drop at 0.2 A	[V]	≤ 2
EMC		EN61000-6-4 / EN61000-6-2
Min. distance to next AC solenoid	[m]	> 0.1
Interface		M12x1 acc. to IEC 61076-2-101
Wiring min.	[mm ²]	3 x 0.14 braided shield recommended
Wiring length max.	[m]	50 recommended

2

M12 pin assignment

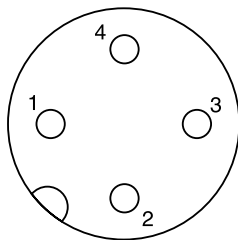

- 1 U_s 10...30 V
- 2 not connected
- 3 0 V
- 4 Out A: normally open

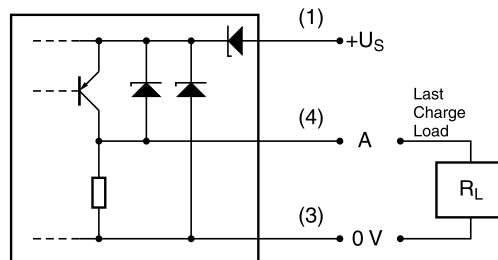

Definitions

Start position monitored:

The valve is de-energized. The inductive switch gives a signal at the moment when the spool leaves the center position (below 15 % spool stroke).

At the switching point the spool is located within the closed position. It is secured that only the flow paths of the offset position are granted.

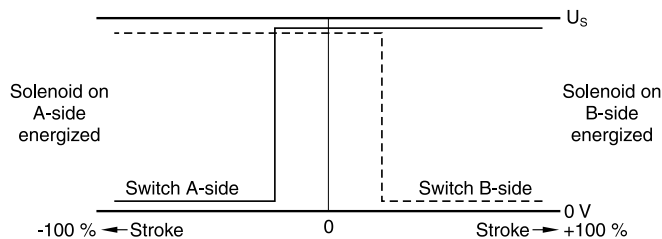

End position monitored:

The inductive switch gives a signal before the end position is reached (above 85 % spool stroke).

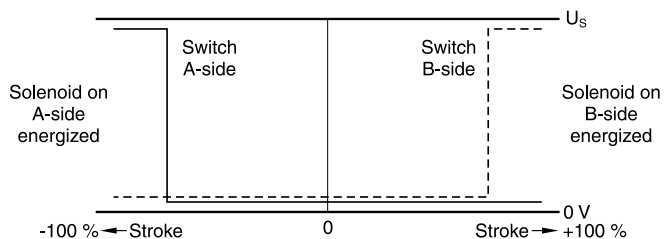

Please order plug M12 x 1 separately. Straight plug recommended – no defined position possible for angled plug.

The flow curve diagram shows the flow versus pressure drop curves for all spool types. The relevant curve

number for each spool type, operating position and flow direction is given in the table below.

Spool	Position „b“		Position „a“		Position „0“				
	P->A	B->T	P->B	A->T	P->A	P->B	A->T	B->T	P->T
001	2	2	2	2	-	-	-	-	-
002	1	4	1	4	1	1	5	5	2
003	3	4	3	6	-	-	7	-	-
004	2	3	2	3	-	-	7	7	-
005	2	2	2	2	12	-	-	-	-
015	3	6	3	4	-	-	-	7	-
016	2	2	2	2	-	12	-	-	-
020 B	4	4	2	3	-	-	-	-	-
026 B	4	-	4	-	-	-	-	-	-
030 B	2	3	1	2	-	-	-	-	-

2

Flow curve diagram

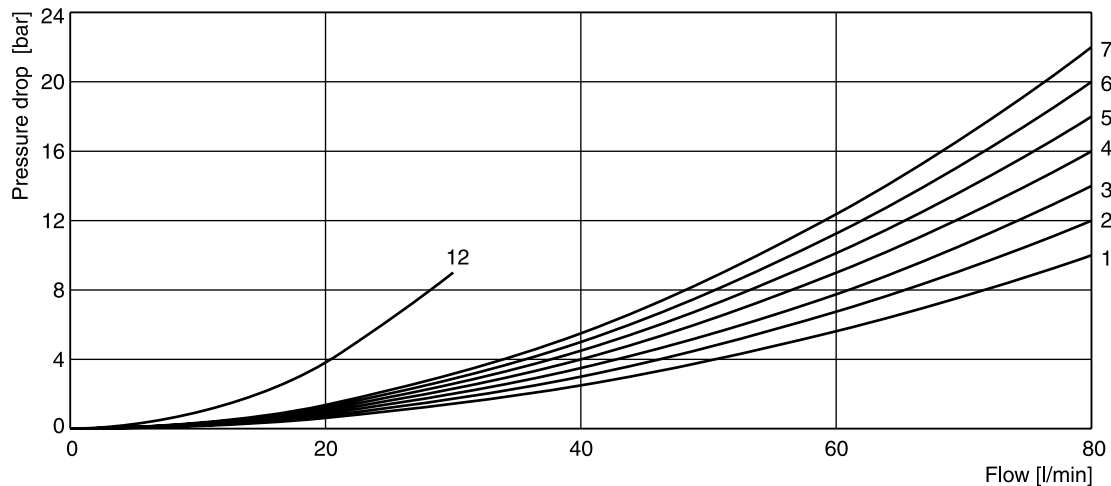

All characteristic curves measured with HLP46 at 50 °C.

Shift limit diagram

The diagram below specifies the shift limits. Valves with spool position “F” or “M” can only be operated up to 70 % of the limits. The specifications apply to a viscosity of 40 mm²/s and balanced flow conditions. The shift limits can

be considerably lower at unbalanced flow conditions. To avoid flow rates beyond the shift limits, a plug-in orifice can be inserted in the P-port.

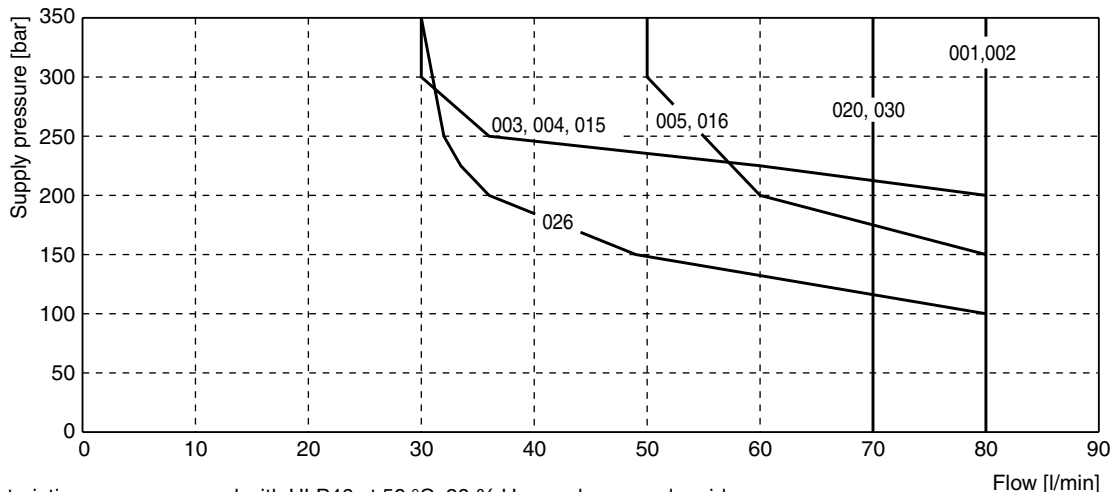

All characteristic curves measured with HLP46 at 50 °C, 90 % U_{nom} and warm solenoids.

Interface EN 175301-803, DC solenoid, without plug M12x1¹⁾
B, E, F -style

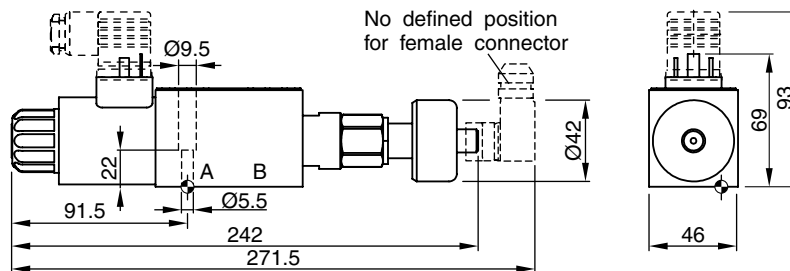

H, K, M -style

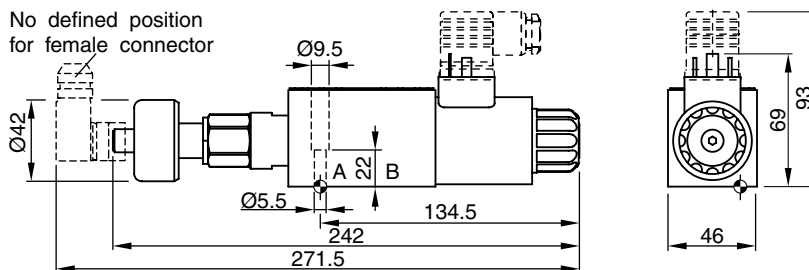

Interface EN 175301-803, DC solenoid, without plug M12x1²⁾
C, D -style

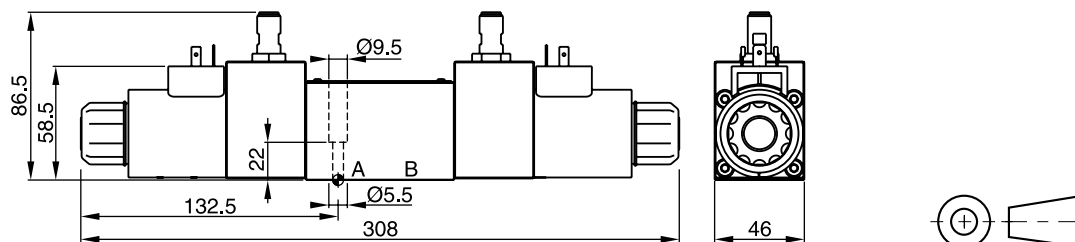

Surface finish	Kit	Kit	Kit	Kit
	BK375	4x M5x30 ISO 4762-12.9	7.6 Nm ±15 %	NBR: SK-D1VW-N-91 FPM: SK-D1VW-V-91

The space necessary to remove the plug per EN 175301-803, design type AF is at least 15 mm.

The torque for the screw M3 of the plug has to be 0.5 to 0.6 Nm.

The space necessary to remove the M12x1 female connector is at least 22 mm.

Attention:

The adjustment of the position control is factory set and sealed. Replacement and repairs can only be undertaken by the manufacturer.

¹⁾ Please order plug M12x1 separately (see accessories, plug M12x1; order no.: 5004109).

²⁾ Please order plug M12x1 separately. Straight plug recommended – no defined position possible for angled plug.

Characteristics

The D1VW with explosion proof solenoids is based on the standard D1VW series. The specific solenoid design allows the usage in hazardous environments.

The explosion proof class is

CE Ex II 2 G
Ex e mb IIC T4 Gb

for use in zone 1 and 2 (according to ATEX). Additionally the solenoids are IECEx compliant.

All explosion proof solenoids are DC design. The valves for AC operate with integrated rectifier.

For further explosion proof valves please refer to catalogue MSG11-3343/UK.

Download of the PDF file at www.parker.com/ISDE, see "Support".

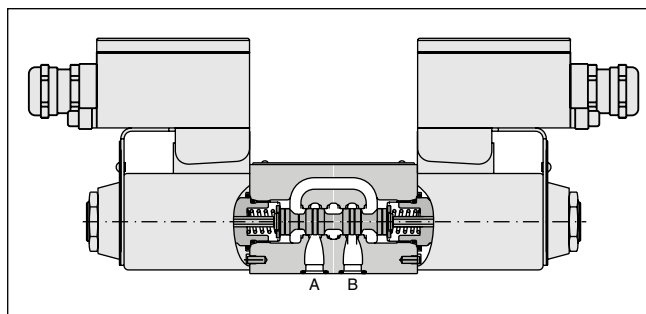
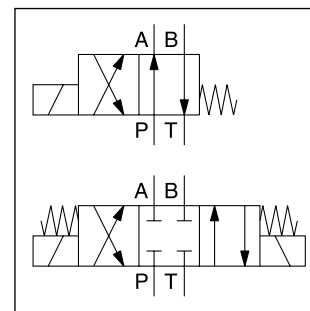
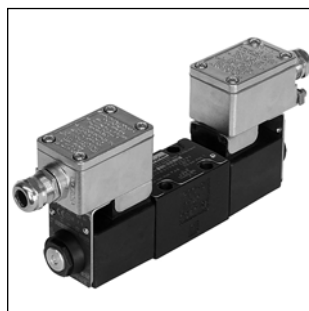

Technical data

General				
Design	Directional spool valve			
Actuation	Solenoid			
Size	DIN NG06 / CETOP 03 / NFPA D03			
Mounting interface	DIN 24340 A6 / ISO 4401 / CETOP RP 121-H / NFPA D03			
Mounting position	unrestricted, preferably horizontal			
Ambient temperature	[°C] -20 ... +60			
MTTF _D	[years] 150			
Weight	[kg] 1.8 (1 solenoid), 2.7 (2 solenoids)			
Hydraulic				
Max. operating pressure	[bar] P, A B: 350; T: 210			
Fluid	Hydraulic oil according to DIN 51524			
Fluid temperature	[°C] -20 ... +60			
Viscosity permitted	[cSt] / [mm ² /s] 2.8 ... 400			
Viscosity recommended	[cSt] / [mm ² /s] 30 ... 80			
Filtration	ISO 4406 (1999); 18/16/13			
Flow max.	[l/min] 60 (see shift limits)			
Leakage at 50 bar	[ml/min] Up to 10 per flow path, depending on spool			
Static / Dynamic				
Step response at 95 %	[ms] Energized: 32 (DC), 40 (AC) De-energized: 40 (DC), 75 (AC)			
Electrical characteristics				
Duty ratio	100 % ED; CAUTION: coil temperature up to 135 °C possible			
Max. switching frequency	[1/h] 15000 (DC), 7200 (AC)			
Protection class	CE Ex II 2 G , Ex e mb IIC T4 Gb, IP66 (plugged and mounted correctly)			
	Code	J	N	P
Supply voltage / ripple	[V]	24 V =	230/50 Hz	110/50 Hz
Tolerance supply voltage	[%]	±10	±10	±10
Current consumption	[A]	1.0	0.12	0.25
Power consumption	[W]	24	24	24
Solenoid connection		Box with M20x1.5 entry for cable glands. Solenoid identification as per ISO 9461.		
Wiring min.	[mm ²]	3 x 1.5 recommended		
Wiring length max.	[m]	50 recommended		

With electrical connections the protective conductor (PE \downarrow) must be connected according to the relevant regulations.

Ordering Code

**Directional Control Valve
Series D1VW Explosion Proof**

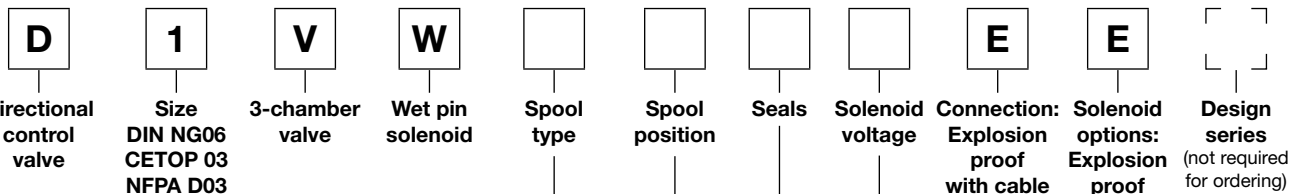

2

3 position spools	
Code	Spool type
	a 0 b
001	
002	
003	
004	
005	
006	
007	
008 ¹⁾	
009 ¹⁾	
010	
011	
014	
015	
016	
021	
022	
081	
082	
102	

2 position spools	
Code	Spool type
	a b
020	
026	
030	
101	

Code	Voltage
J	24 V=
P	110 V 50 Hz
N	230 V 50 Hz

Code	Seals
N	NBR
V	FPM

3 position spools		
Code	Spool position	
C		3 positions. Spring offset in position "0". Operated in position "a" or "b".
	Standard	Spool type 008, 009
E		2 positions. Spring offset in position "0". Operated in position "a".
		Operated in position "b".
K		2 positions. Spring offset in position "0". Operated in position "b".
		Operated in position "a".

2 position spools		
Code	Spool position	
B		2 positions. Spring offset in position "b". Operated in position "a".
D		2 positions. Operated in position "a" or "b". No center or offset position.
H		2 positions. Spring offset in position "a". Operated in position "b".

¹⁾ Consider specific spool position.

Further spool types, styles, and combinations on request.

The flow curve diagram shows the flow versus pressure drop curves for all spool types. The relevant curve

number for each spool type, operating position and flow direction is given in the table below.

2

Spool	Position "b"			Position "a"			Position "0"				
	P-A	B-T	P-B	P-B	A-T	P-A	P-A	P-B	A-T	B-T	P-T
001	2	2		2	2						
002	1	4		1	4		1	1	5	5	2
003	3	4		3	6				7		
004	2	3		2	3				7	7	
005	2	2		2	2		12				
006	1	4		1	4		7	7			
007	3	2		2	2			3		2	7
010	3			3							
011	2	2		2	2				14	14	
014	3	2		2	2		3		2		7
015	3	6		3	4					7	
016	2	2		2	2			12			
020B	4	4		2	3						
026B	4			4							
030B	2	3		1	2						
081	13	13		13	13						
082	13	13		13	13				1)	1)	
101B	11	10		10	9						
102	1	4		1	4		5	5	8	8	6
	P-B	A-T		P-A	B-T		P-A	P-B	A-T	B-T	P-T
008	4	5		4	5						9
009	5	5		6	7						7

Spool	Position "b"			Position "a"		
	P-A	P-B	A-B	P-B	A-T	
021	2	4		4	2	
	P-A	B-T		P-A	P-B	A-B
022	6	2		5	2	

Flow curve diagram

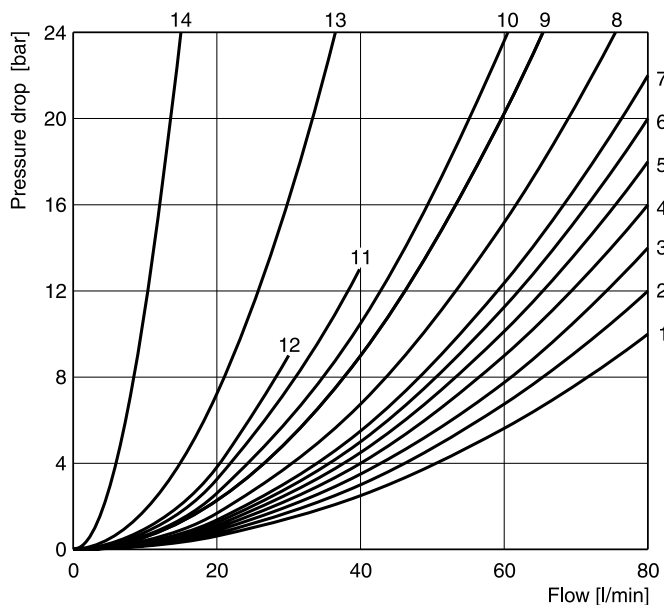

All characteristic curves measured with HLP46 at 50 °C.

1) Only for pressure compensation, no high flow possible.

The diagram below specifies the shift limits for valves with AC and DC solenoids. The specifications apply to a viscosity of 40 mm²/s and balanced flow conditions. The

shift limits can be considerably lower at unbalanced flow conditions. To avoid flow rates beyond the shift limits, a plug-in orifice can be inserted in the P-port.

2

Shift limit diagram with DC solenoid

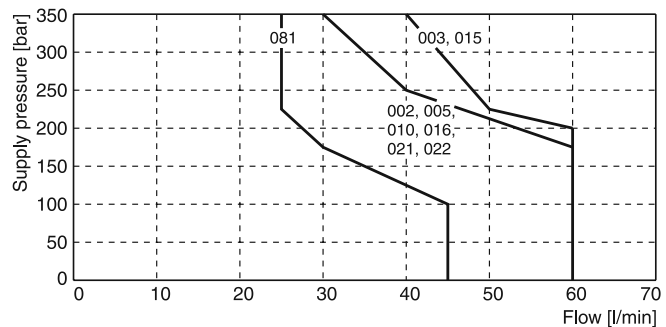
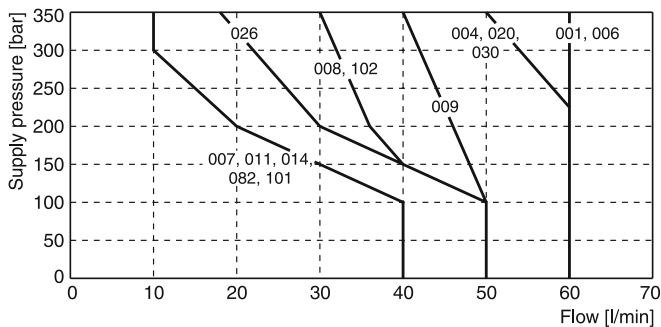

Measured with HLP46 at 50 °C, 90 % U_{nom} and warm solenoids

Shift limit diagram with AC solenoid

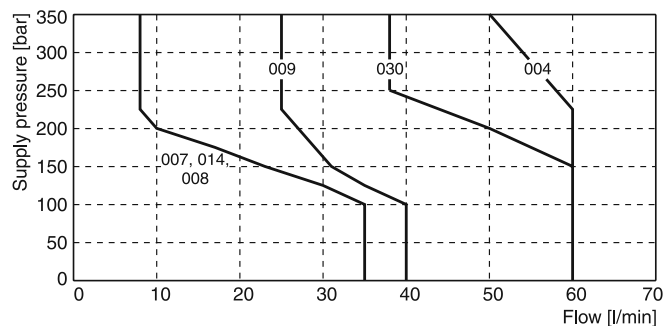
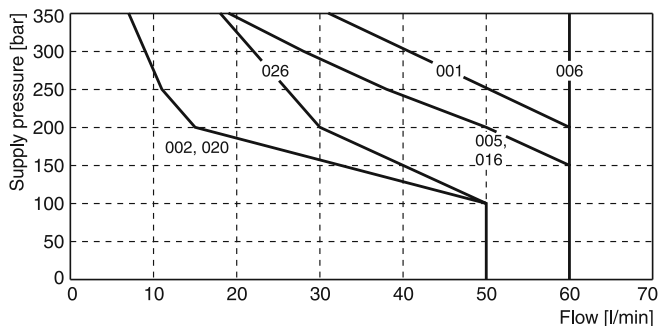

Measured with HLP46 at 50 °C, 95 % U_{nom} and warm solenoids

Dimensions

Dimensions

B, E -style

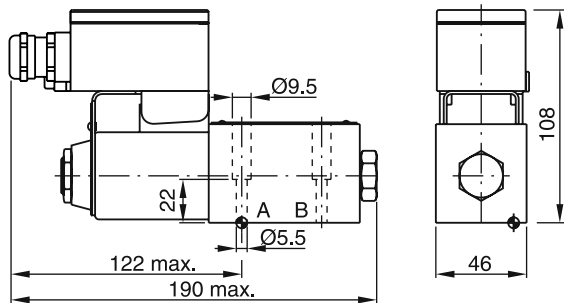



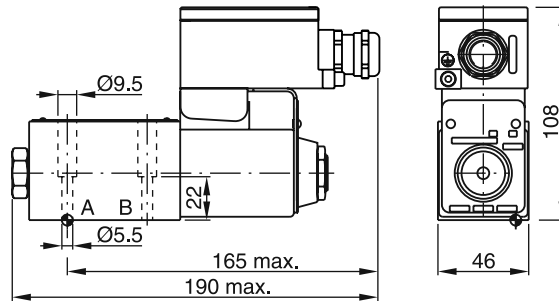

H, K -style

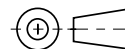
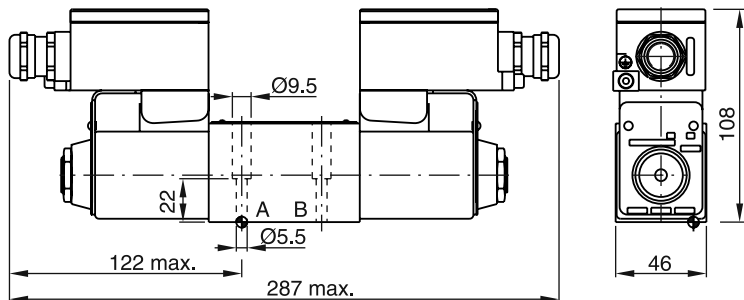

C, D -style

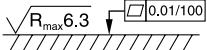

Surface finish	 Kit	 Kit	 Kit	 Kit NBR
	BK375	4x M5x30 ISO 4762-12.9	7.6 Nm ±15 %	NBR: SK-D1VW-N-91 FPM: SK-D1VW-V-91