

General Description

Series PR pilot operated pressure reducing/relieving valves are used to regulate pressure in one area of a circuit at a set pressure below the normal system pressure. An integral relieving function limits the secondary circuit pressure. Options are A port control, B port control and P port control. The A & B valves feature a reverse flow check.

Features

- High flow capacity.
- Sizes:
 - PR05 – NFPA D05 / NG10 / CETOP 5
 - PR5H – NFPA D05HE / NG10 / CETOP 5H
 - PR07 – NFPA D07 / NG16 / CETOP 7
 - PR08 – NFPA D08 / NG25 / CETOP 8
- With integral return flow check valve on A & B port models.

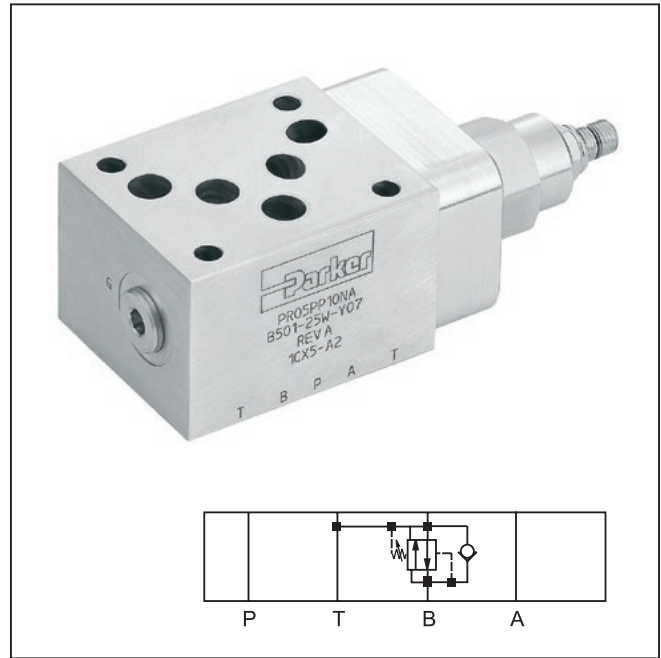

Specifications

General				
Size	D05 / NG10	D05HE / NG10	D07 / NG16	D08 / NG25
Mounting Position	Unrestricted			
Ambient Temperature Range	-20°C to +50°C (-4°F to +122°F)			
Hydraulic				
Maximum Operating Pressure	Aluminum Body – up to 207 Bar (3000 PSI); Ductile Iron Body – up to 345 Bar (5000 PSI)			
Nominal Flow	76 LPM (20 GPM)	76 LPM (20 GPM)	303 LPM (80 GPM)	303 LPM (80 GPM)
Adjustment Screw Hex Size	5/32	5/32	5/32	5/32
Fluid Temperature	-20°C to +80°C (-4°F to +176°F)			
Viscosity	Permitted 10 to 650 cSt / mm ² /s (46 to 3013 SSU) Recommended 30 cSt / mm ² /s (139 SSU)			
Filtration	ISO Class 4406 (1999) 18/16/13 (acc. NAS 1638: 7)			

PR

Pressure Reducing/Relieving Valve

Size

Code	Description
03	See PRDM2
05	NFPA D05 / NG10
5H*	NFPA D05HE / NG10
07	NFPA D07 / NG16
08	NFPA D08 / NG25

* Valve comes with D05HE (ISO) Pattern seal plate (990-120-012). If D05H pattern is required, order seal plate kit 990-120-009.

Style

Code	Description
AA	Pressure reducing in A with check valve
BB	Pressure reducing in B with check valve
PP	Pressure reducing in P

Pressure Range

Code	Description
10	13.8 Bar (200 PSI)**
	6.9 to 207 Bar (100 to 3000 PSI)
20*	13.8 Bar (200 PSI)**
	10.4 to 310 Bar (150 to 4500 PSI)

* Ductile iron body only.

** Standard setting.

Seal

Code	Description
N	Nitrile
V*	Fluorocarbon

* Upon request.

Body Material

Code	Description
A	Aluminum
D	Ductile Iron

PRAA**

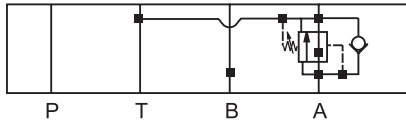

PRBB**

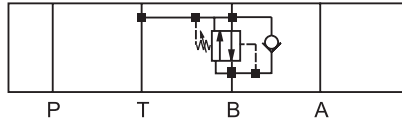

PRPP**

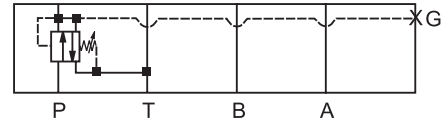

Weight:

Size	PR**AA30NA	PR**AA30ND	PR**BB30NA	PR**BB30ND	PR**PP30NA	PR**PP30ND
PR05, PR5H	1.4 kg (3.1 lbs.)	2.8 kg (6.2 lbs.)	1.4 kg (3.1 lbs.)	2.8 kg (6.2 lbs.)	0.9 kg (2.1 lbs.)	2.0 kg (4.4 lbs.)
PR07	2.9 kg (6.4 lbs.)	5.8 kg (12.9 lbs.)	2.9 kg (6.4 lbs.)	5.7 kg (12.6 lbs.)	3.9 kg (8.5 lbs.)	7.8 kg (17.1 lbs.)
PR08	4.9 kg (10.8 lbs.)	9.2 kg (20.4 lbs.)	4.9 kg (10.8 lbs.)	11.2 kg (24.7 lbs.)	5.3 kg (11.6 lbs.)	11.7 kg (25.7 lbs.)

PR05*10*A and PR5H*10*A

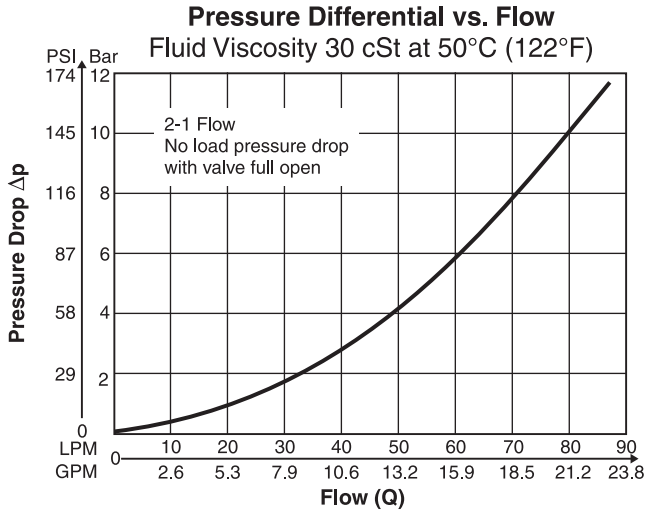

PR05*10*A and PR5H*10A

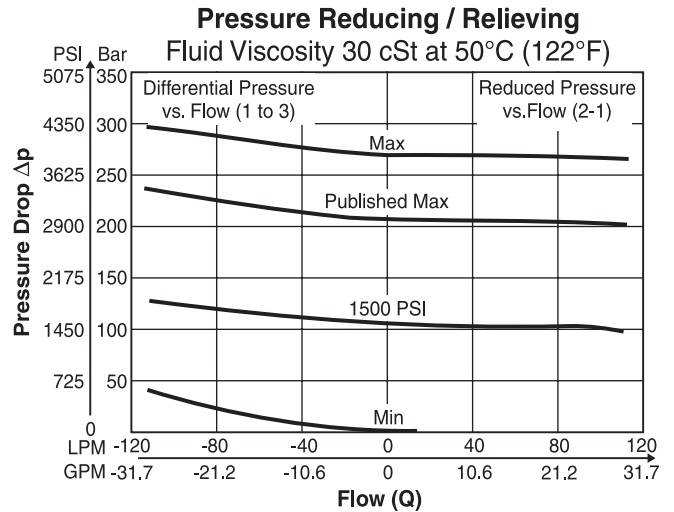

PR05*20*D and PR5H*20*D

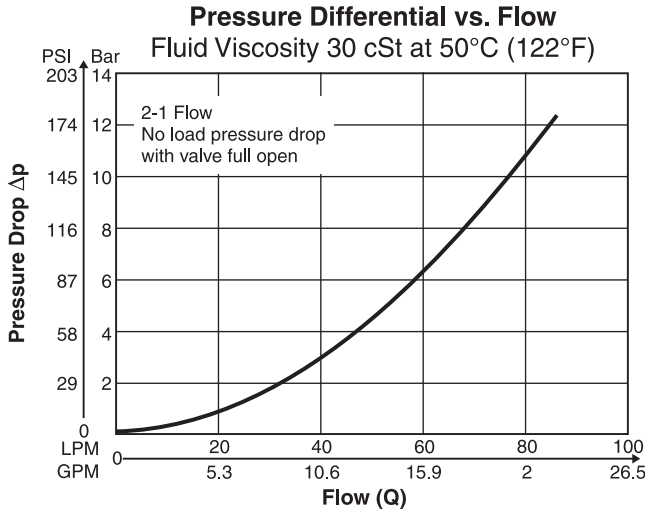

PR05*20*D and PR5H*20*D

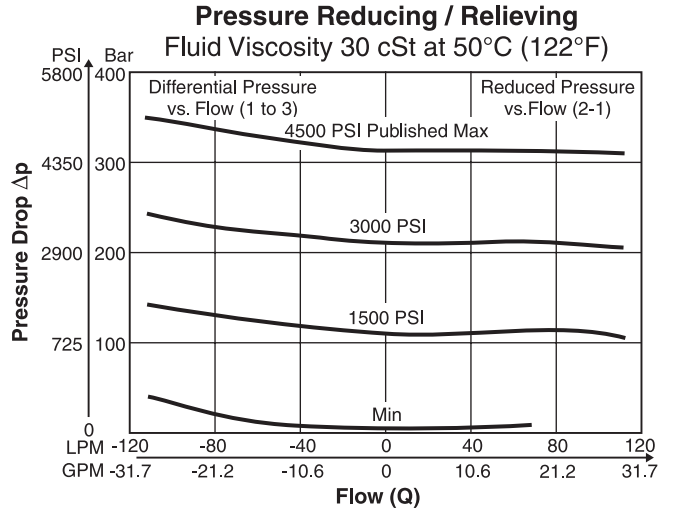

PR07*10*A

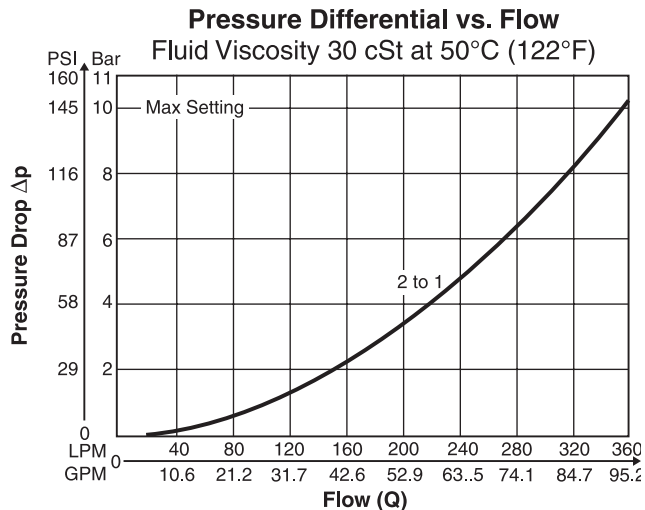

PR07*10*A

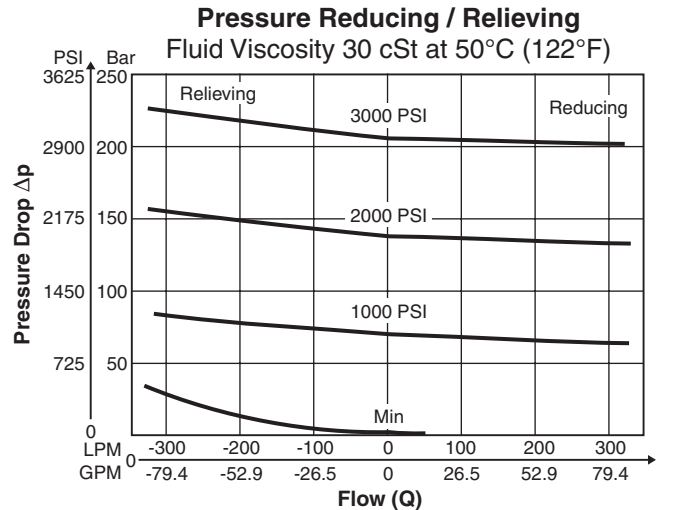

PR07*20*D

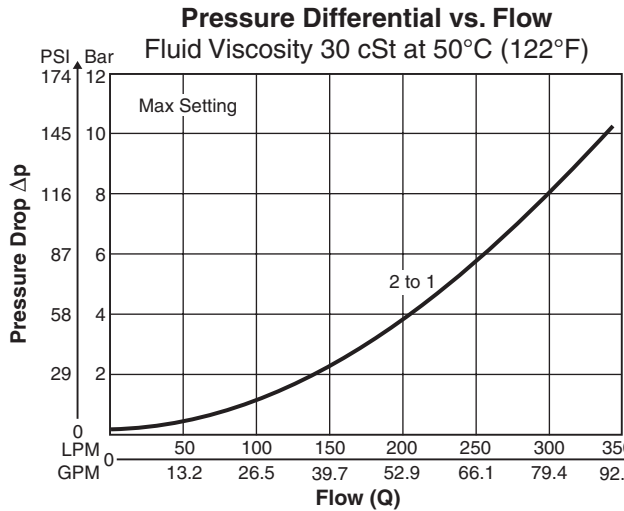

PR07*20*D

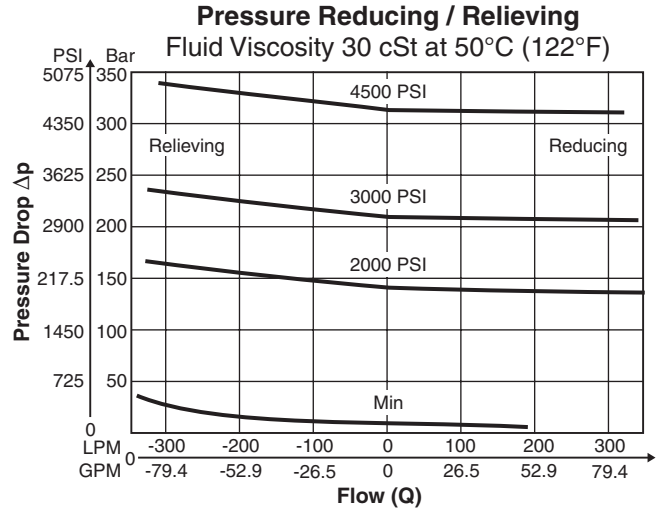

PR08*10*A

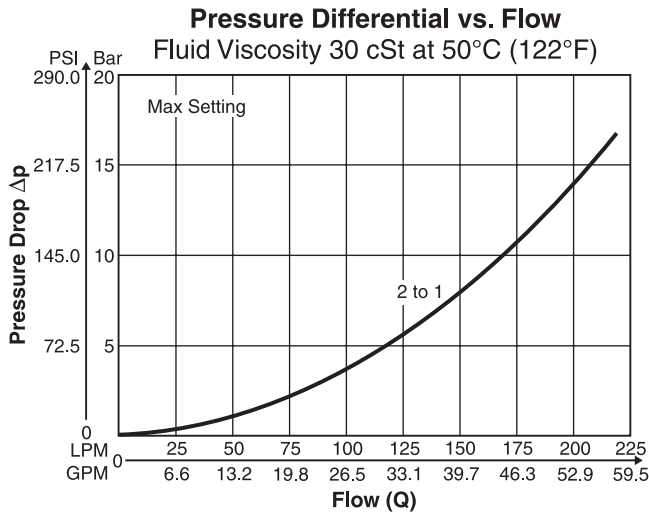

PR08*10*A

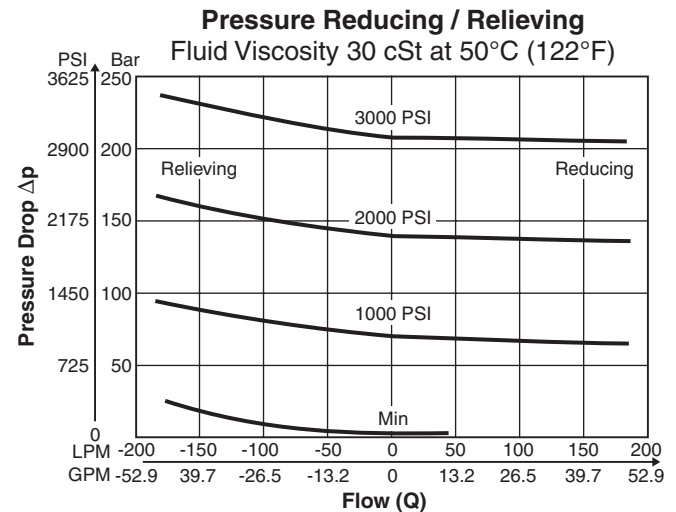

PR08*20*D

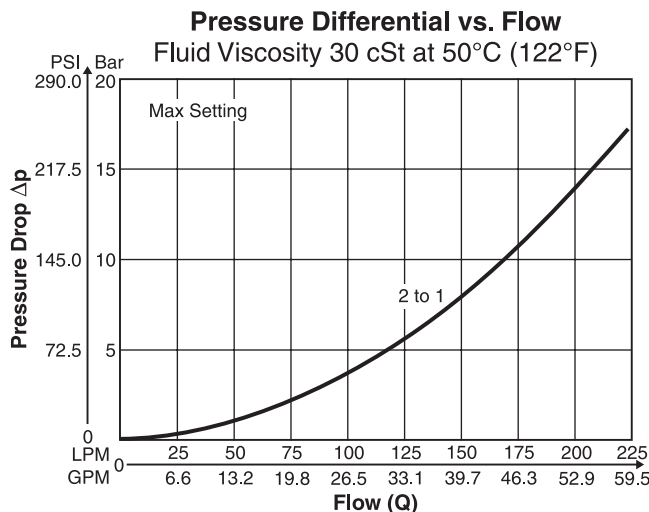

PR08*20*D

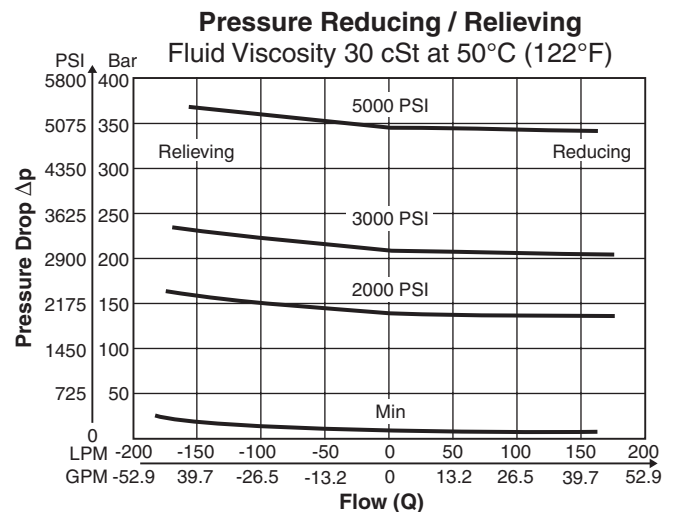

Dimensions

PR05AA – Inch equivalents for millimeter dimensions are shown in (**)

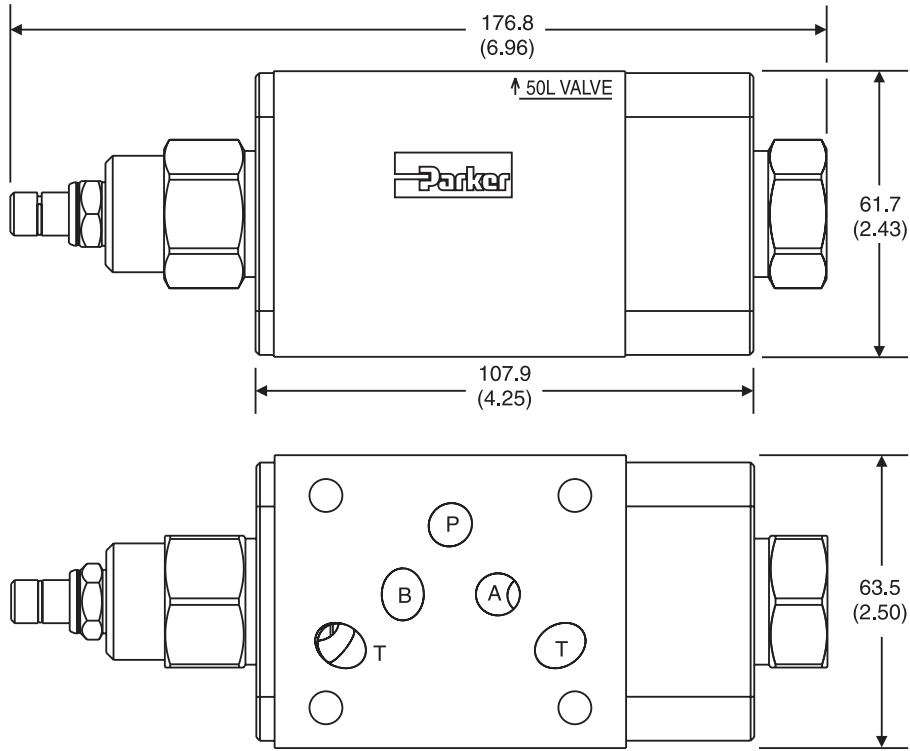

PR05BB – Inch equivalents for millimeter dimensions are shown in (**)

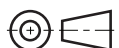
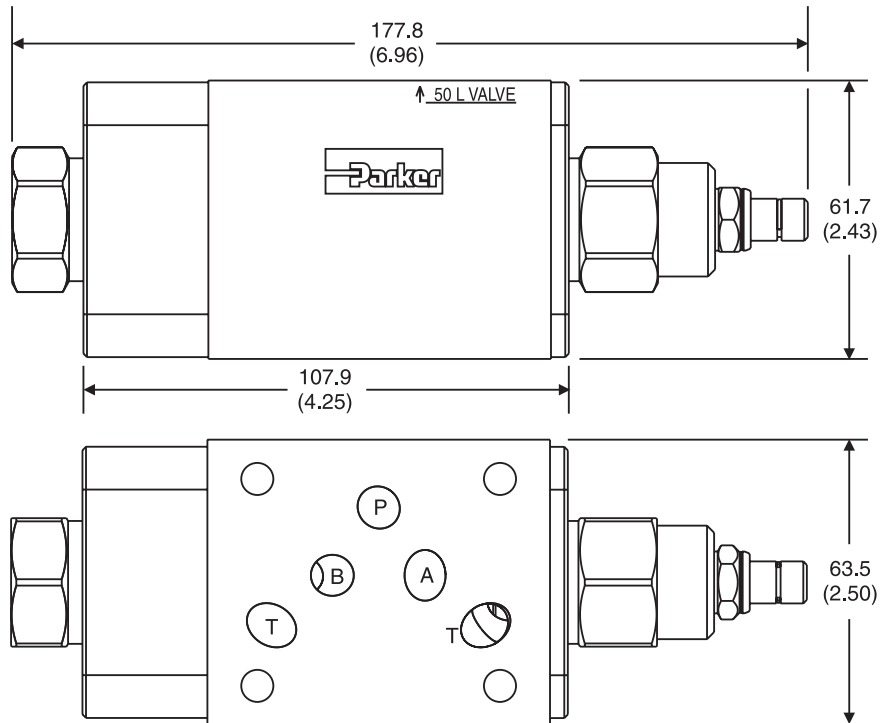

Dimensions

PR05PP – Inch equivalents for millimeter dimensions are shown in (**)

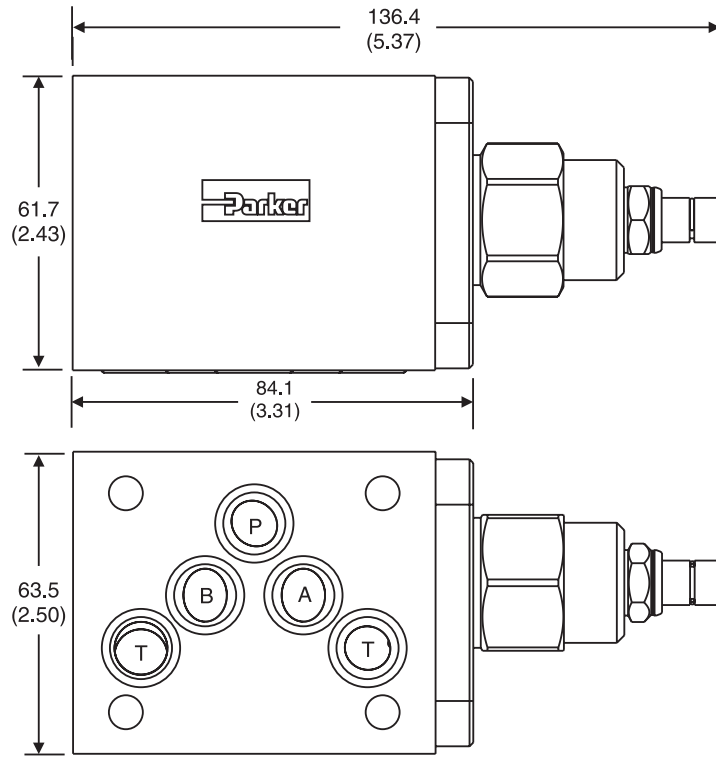

PR5HAA – Inch equivalents for millimeter dimensions are shown in (**)

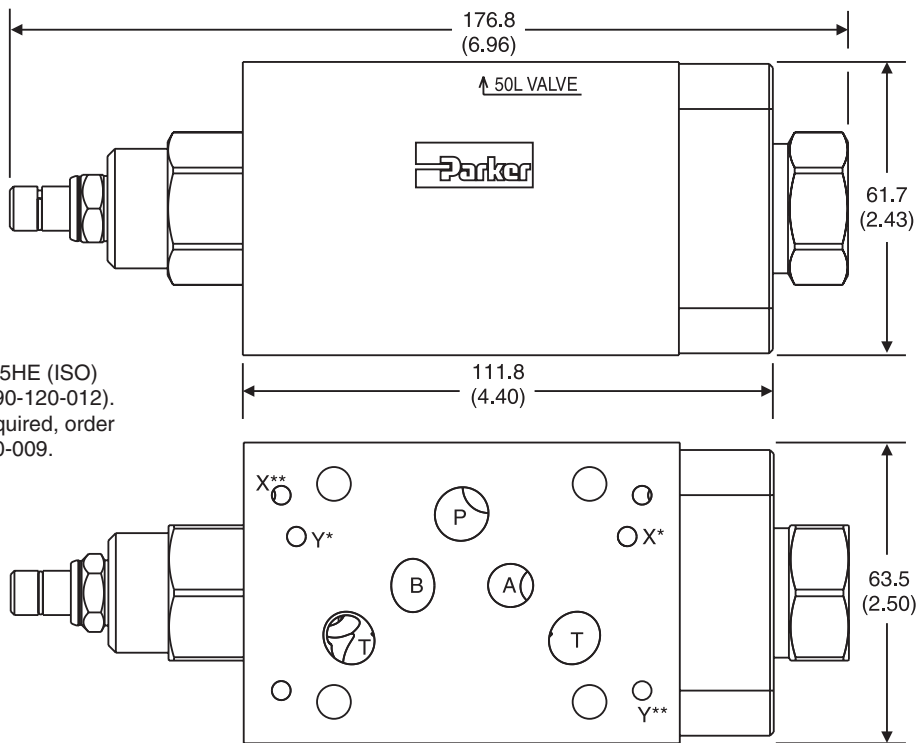

Valve comes with D05HE (ISO) Pattern seal plate (990-120-012). If D05H pattern is required, order seal plate kit 990-120-009.

* D05HE (Standard)
** D05H



Dimensions

PR5HBB – Inch equivalents for millimeter dimensions are shown in (**)

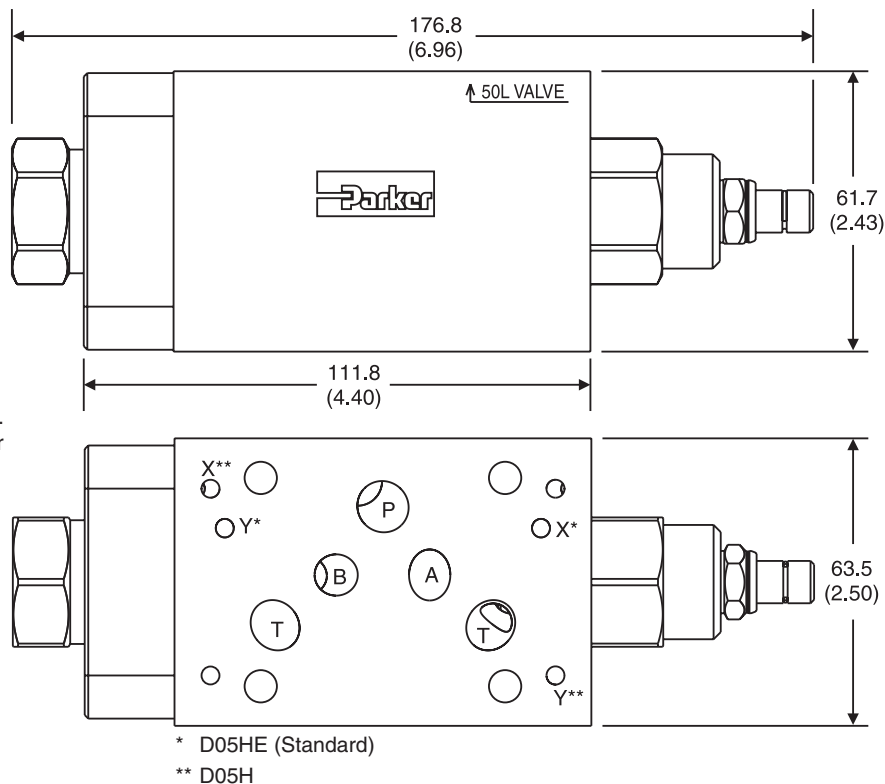

Valve comes with D05HE (ISO) Pattern seal plate (990-120-012). If D05H pattern is required, order seal plate kit 990-120-009.

PR5HPP – Inch equivalents for millimeter dimensions are shown in (**)

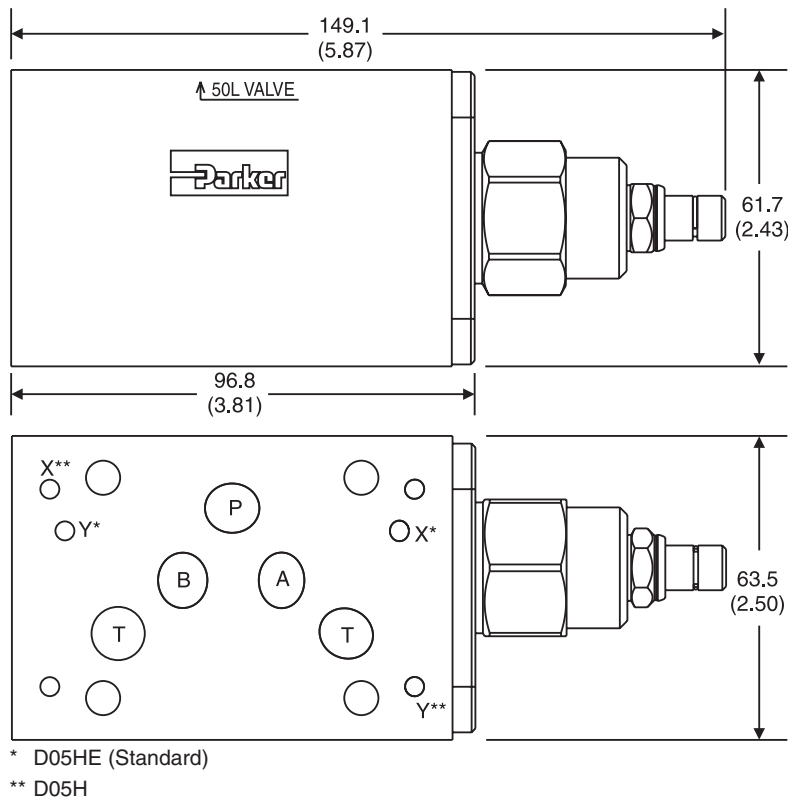

Valve comes with D05HE (ISO) Pattern seal plate (990-120-012). If D05H pattern is required, order seal plate kit 990-120-009.



Dimensions

PR07AA – Inch equivalents for millimeter dimensions are shown in (**)

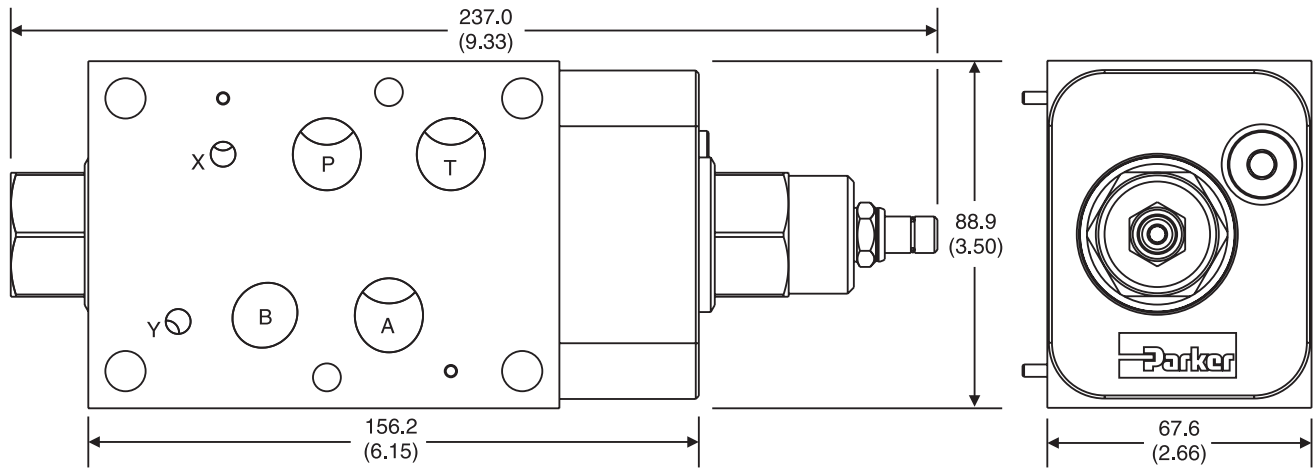

PR07BB – Inch equivalents for millimeter dimensions are shown in (**)

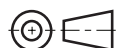
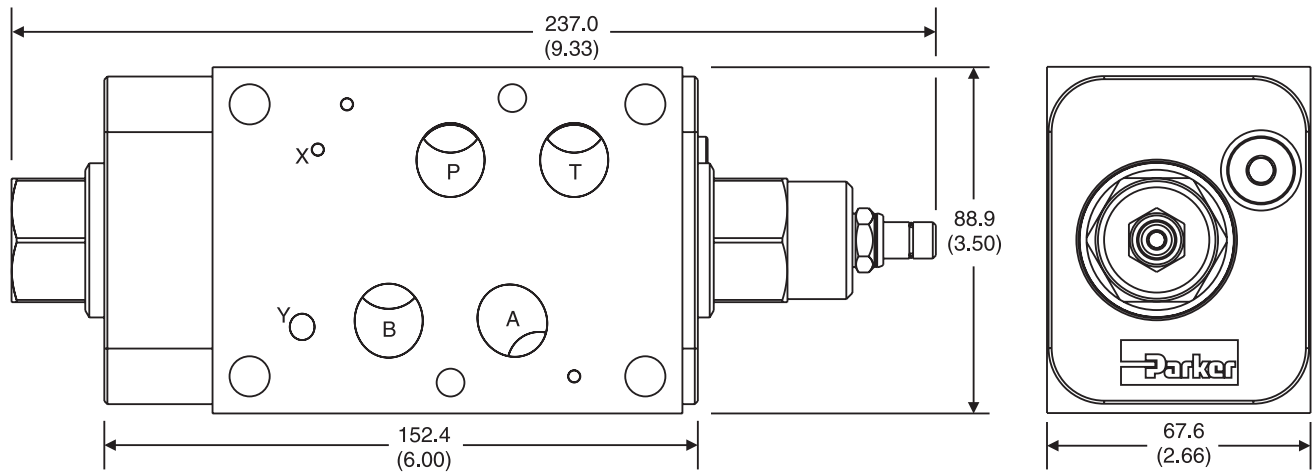

Dimensions

PR07PP – Inch equivalents for millimeter dimensions are shown in (**)

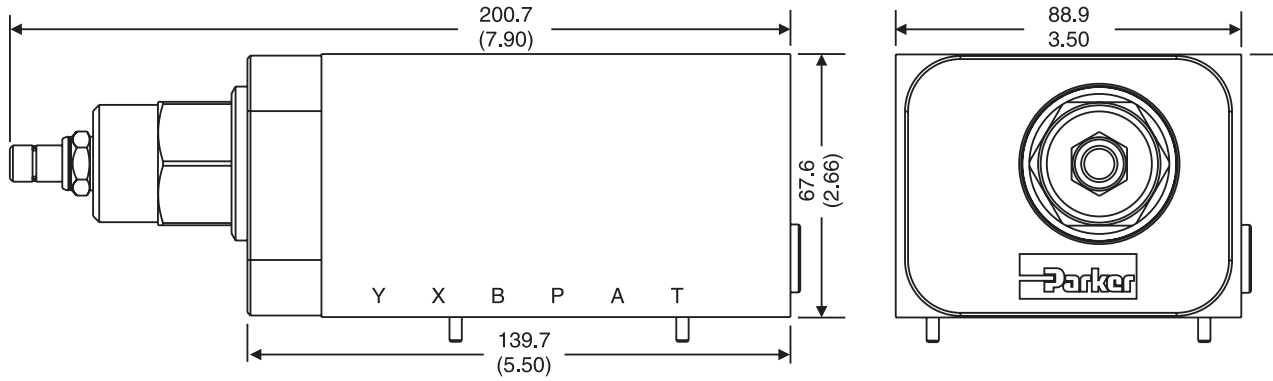

PR08AA – Inch equivalents for millimeter dimensions are shown in (**)

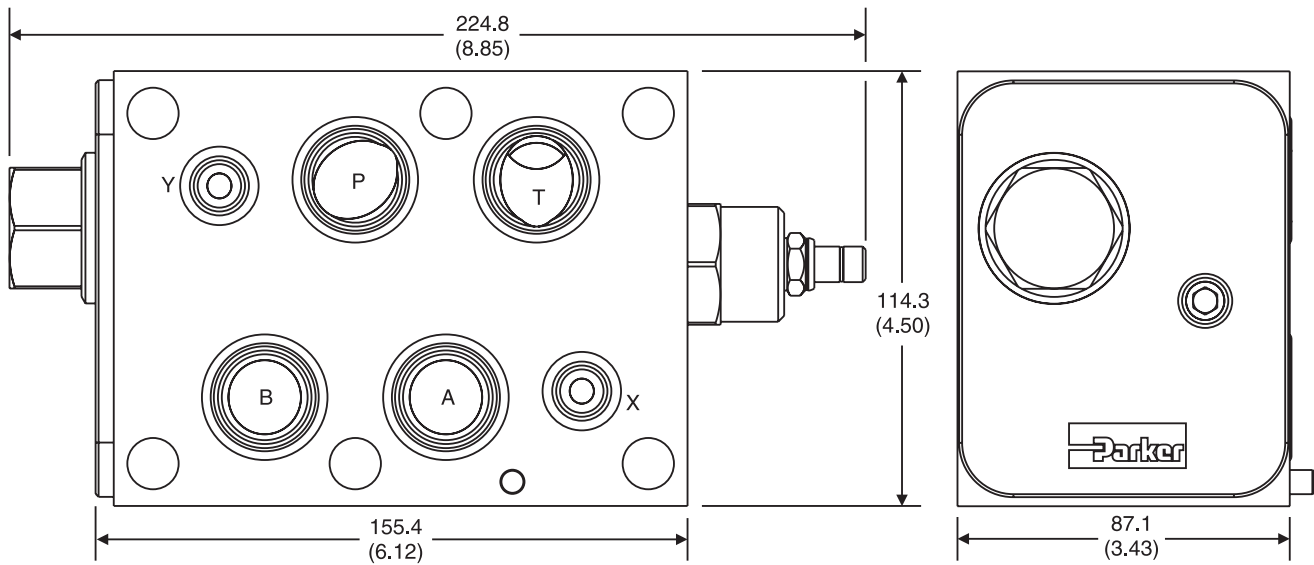

Dimensions

PR08BB – Inch equivalents for millimeter dimensions are shown in (**)

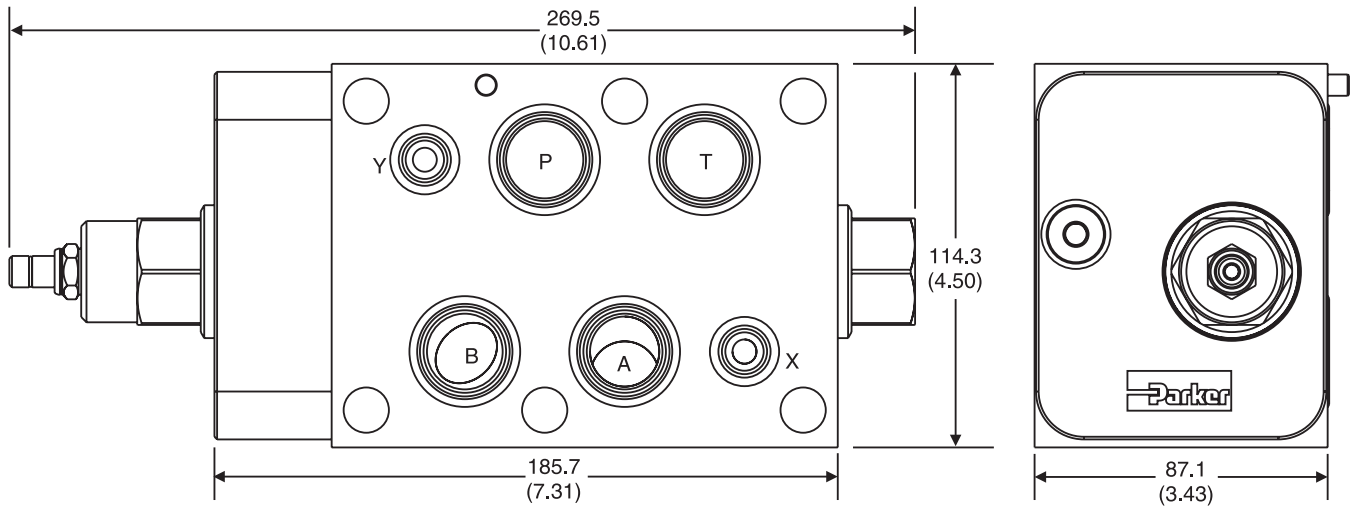

PR08PP – Inch equivalents for millimeter dimensions are shown in (**)

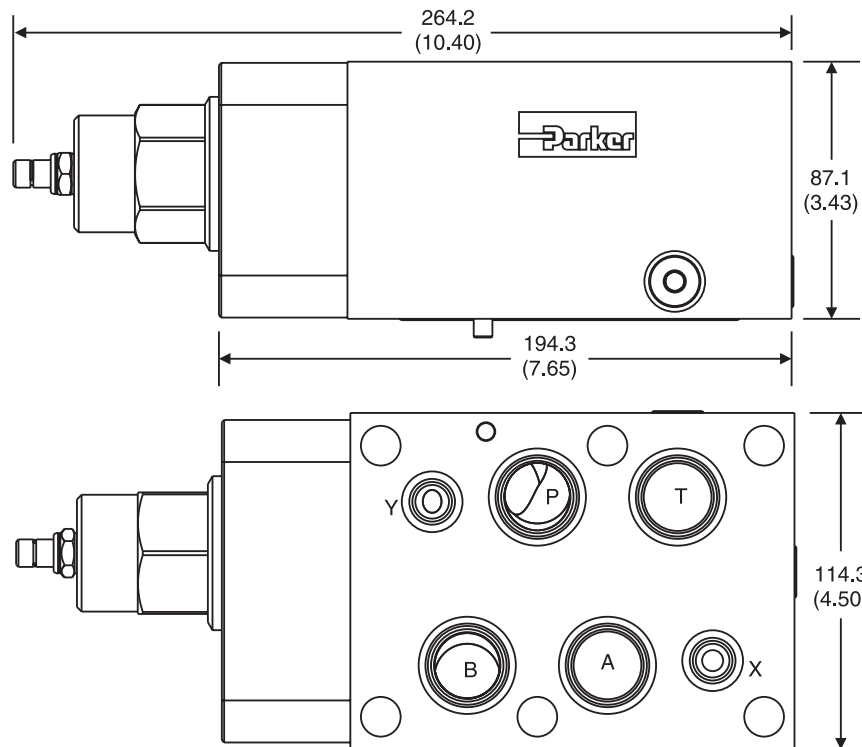



WARNING – USER RESPONSIBILITY

FAILURE OR IMPROPER SELECTION OR IMPROPER USE OF THE PRODUCTS DESCRIBED HEREIN OR RELATED ITEMS CAN CAUSE DEATH, PERSONAL INJURY AND PROPERTY DAMAGE.

- This document and other information from Parker-Hannifin Corporation, its subsidiaries and authorized distributors provide product or system options for further investigation by users having technical expertise.
- The user, through its own analysis and testing, is solely responsible for making the final selection of the system and components and assuring that all performance, endurance, maintenance, safety and warning requirements of the application are met. The user must analyze all aspects of the application, follow applicable industry standards, and follow the information concerning the product in the current product catalog and in any other materials provided from Parker or its subsidiaries or authorized distributors.
- To the extent that Parker or its subsidiaries or authorized distributors provide component or system options based upon data or specifications provided by the user, the user is responsible for determining that such data and specifications are suitable and sufficient for all applications and reasonably foreseeable uses of the components or systems.

OFFER OF SALE

The items described in this document are hereby offered for sale by Parker-Hannifin Corporation, its subsidiaries or its authorized distributors. This offer and its acceptance are governed by the provisions stated in the detailed "Offer of Sale" elsewhere in this document or available at www.parker.com/hydraulicvalve.

SAFETY GUIDE

For safety information, see Safety Guide SG HY14-1000 at www.parker.com/safety or call 1-800-CParker.



Parker Hannifin Corporation
Hydraulic Valve Division
520 Ternes Avenue
Elyria, Ohio 44035 USA
Tel: 440 366 5100
Fax: 440 366 5253
www.parker.com/hydraulicvalve

