

General Description

Series RM relief valves limit system pressure by opening to tank when system pressure reaches the valve setting. With D03 size, they can also be configured to limit the 'A' or 'B' work port pressures independently.

B

Features

- RM sandwich style relief valves can be used to limit pressure in the 'P' port, 'A' port, or 'B' port.
- Valve bodies are manufactured from steel which provide extra strength and durability for longer life. Internal hardened steel components also provide longer life.
- Three pressure adjustment options are available: slotted screw, knob and locking knob.
- SAE Gage Port

Specifications

	RM2	RM3	RM6										
Mounting Pattern	NFPA D03, CETOP 3, NG 6	NFPA D05, CETOP 5, NG 10	NFPA D08, CETOP 8, NG 25										
Minimum Pressure	10 Bar (150 PSI) with rated flow, 150 SSU oil, and fluid temperature of 38°C (100°F). ¹												
Maximum Pressure	350 Bar (5000 PSI)	350 Bar (5000 PSI)	350 Bar (5000 PSI)										
Minimum Flow	3.78 LPM (1 GPM)	3.78 LPM (1 GPM)	3.78 LPM (1 GPM)										
Maximum Flow	53 LPM (14 GPM)	76 LPM (20 GPM)	341 LPM (90 GPM)										
Pressure Range	<table border="0"> <tr> <td>Code</td> <td>Pressure Range</td> </tr> <tr> <td>07</td> <td>10 to 70 Bar (150 - 1000 PSI)</td> </tr> <tr> <td>17</td> <td>10 to 175 Bar (150 - 2500 PSI)</td> </tr> <tr> <td>25</td> <td>10 to 250 Bar (150 - 3500 PSI)</td> </tr> <tr> <td>35</td> <td>10 to 350 Bar (150 - 5000 PSI)</td> </tr> </table>			Code	Pressure Range	07	10 to 70 Bar (150 - 1000 PSI)	17	10 to 175 Bar (150 - 2500 PSI)	25	10 to 250 Bar (150 - 3500 PSI)	35	10 to 350 Bar (150 - 5000 PSI)
Code	Pressure Range												
07	10 to 70 Bar (150 - 1000 PSI)												
17	10 to 175 Bar (150 - 2500 PSI)												
25	10 to 250 Bar (150 - 3500 PSI)												
35	10 to 350 Bar (150 - 5000 PSI)												
Filtration	ISO 4406 (1999); 18/16/13 (meet NAS 1638:7)												
Venting	Connecting the vent port to tank allows the relief valve to divert flow at minimum pressure. ²												
Remote Control	Remote control valve connected to the vent port can be used to control the pressure. ³												

¹ Change in flow, temperature or fluid (SSU) rating will affect valve minimum pressure.

² Not available on Model RM2.

³ Set main valve pressure 10 Bar (150 PSI) higher than remote pilot.

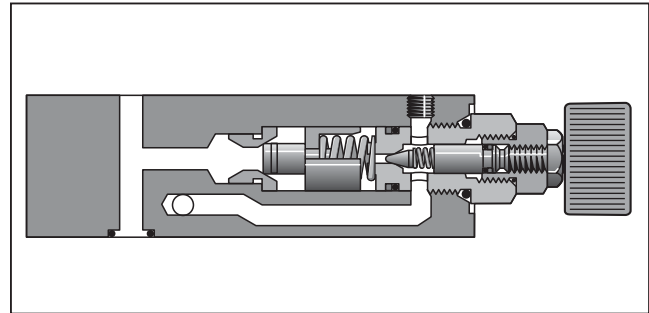
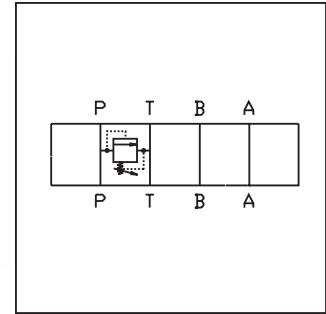

Performance Curves

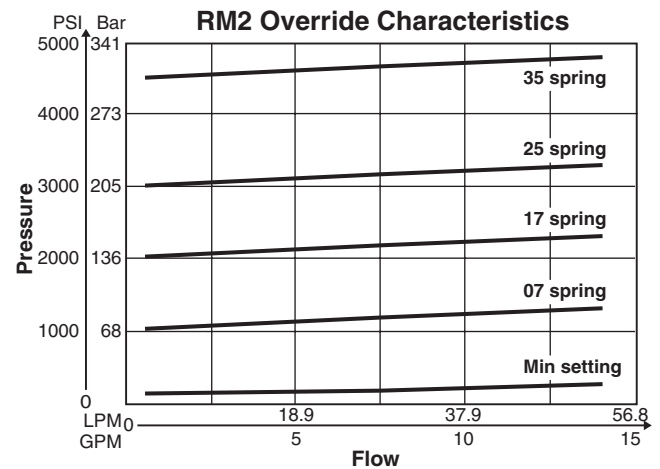

VISCOSITY CORRECTION FACTOR							
Viscosity (SSU)	75	150	200	250	300	350	400
% of ΔP (Approx.)	93	111	119	126	132	137	141

Curves were generated using 100 SSU hydraulic oil. For any other viscosity, pressure drop will change per chart.

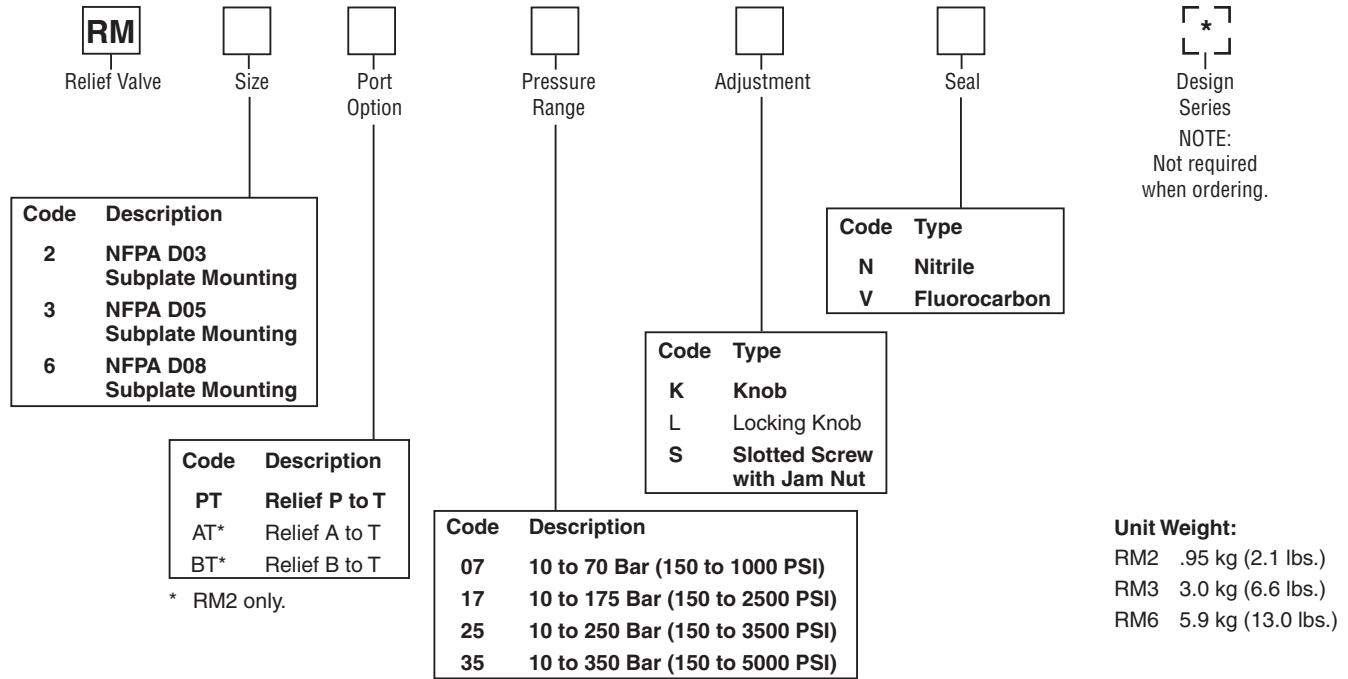

Bold: Designates Tier I products and options.

Non-Bold: Designates Tier II products and options. These products will have longer lead times.

Bolt Kits

Size "2"				Size "3"			
No. of Sandwich	Sandwich & Valve Combination	Bolt Kit	Bolt Length mm (in)	No. of Sandwich	Sandwich & Valve Combination	D3W-30 D3DW & D31*W*	Bolt Length mm (in)
1	Sandwich & D1	BK243	73.2 (2.88)	1	Sandwich & D3	BK141	88.9 (3.50)
2	Sandwich & D1	BK225	111.3 (4.38)	2	Sandwich & D3	BK142	139.7 (5.50)
3	Sandwich & D1	BK244	152.4 (6.00)	3	Sandwich & D3	BK143	190.5 (7.50)
4	Sandwich & D1	BK245	190.5 (7.50)				

* D31VW with internal pilot and internal drain only.

Size "6"			
No. of Sandwich	Sandwich & Valve Combination	Bolt Kit	Bolt Length mm (in)
1	Sandwich & D6	BK121	133.4 (5.25)
2	Sandwich & D6	BK122	203.2 (8.00)
3	Sandwich & D6	BK123	273.1 (10.75)
4	Sandwich & D6	BK124	342.9 (13.5)

Bolt Kits must be ordered separately.

Schematics

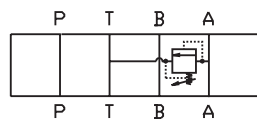

AT Option

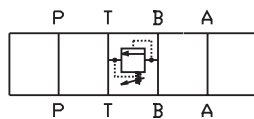

BT Option

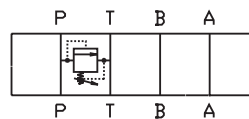

PT Option

B

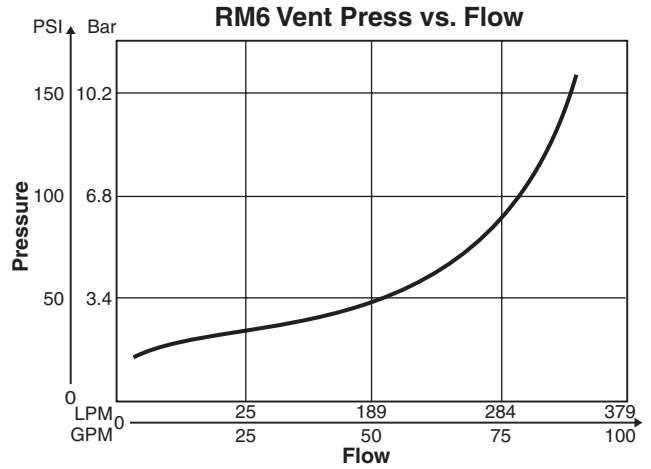
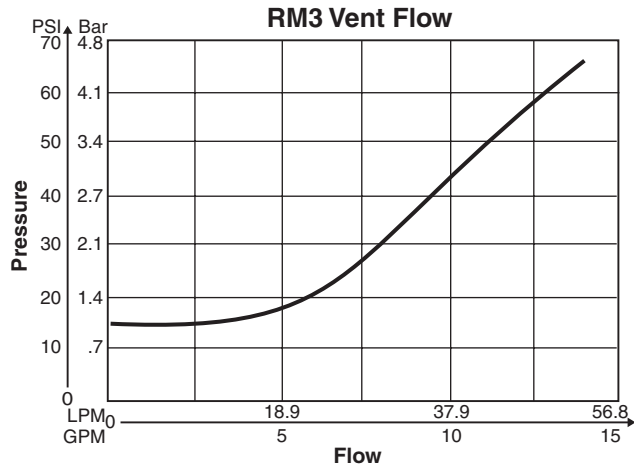
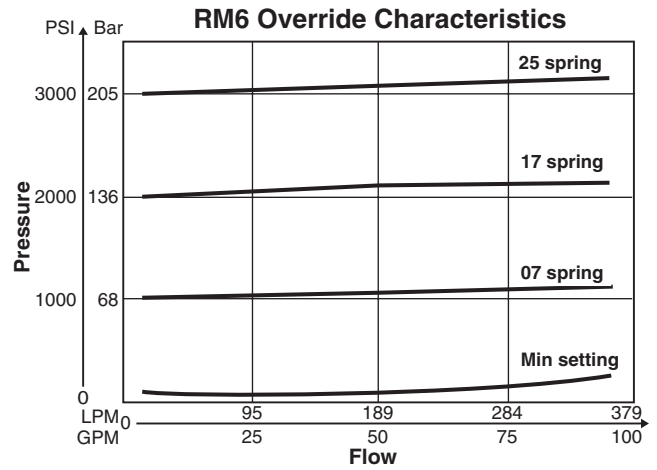
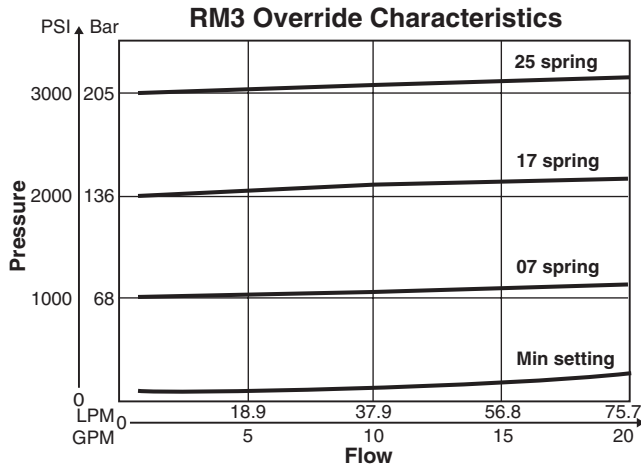

VISCOSITY CORRECTION FACTOR							
Viscosity (SSU)	75	150	200	250	300	350	400
% of ΔP (Approx.)	93	111	119	126	132	137	141
Curves were generated using 100 SSU hydraulic oil. For any other viscosity, pressure drop will change per chart.							

Inch equivalents for millimeter dimensions are shown in (**)

B

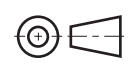
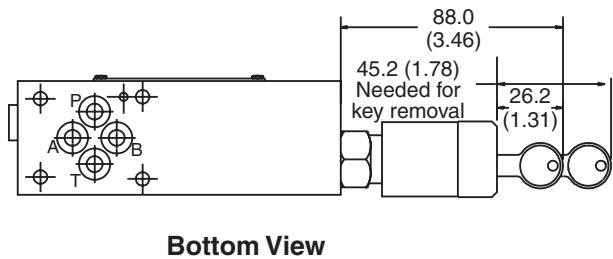
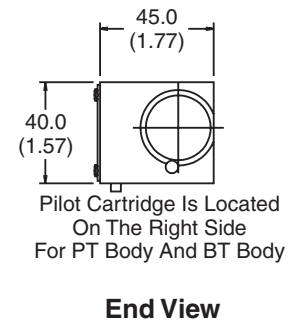
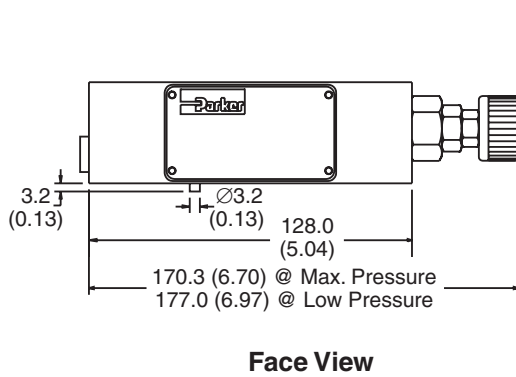
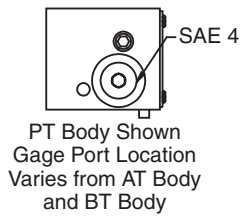
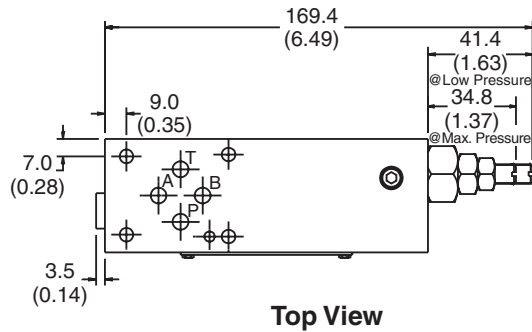

Inch equivalents for millimeter dimensions are shown in (**)

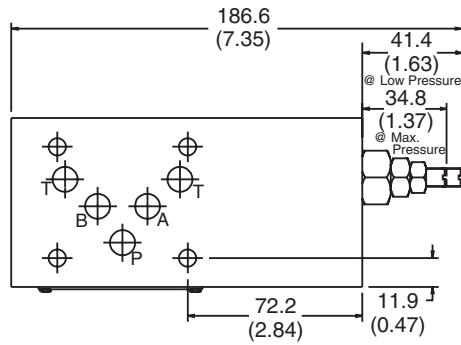

Top View

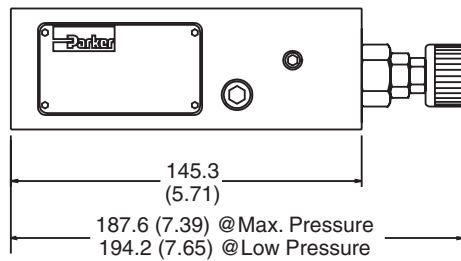
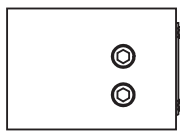

Face View

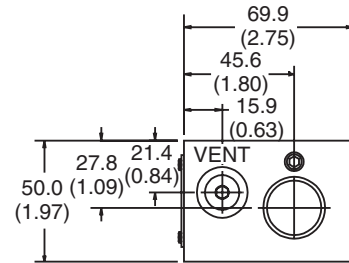

End View

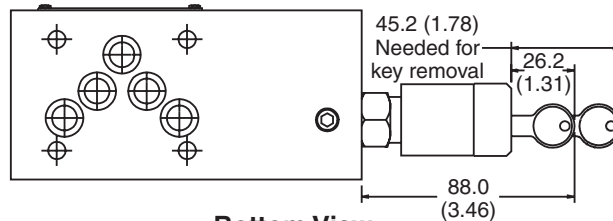

Bottom View

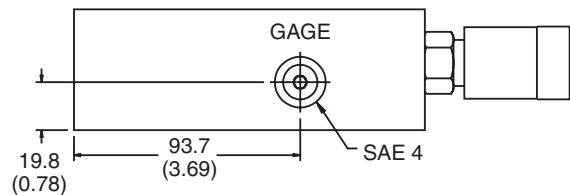

Back View



Inch equivalents for millimeter dimensions are shown in (**)

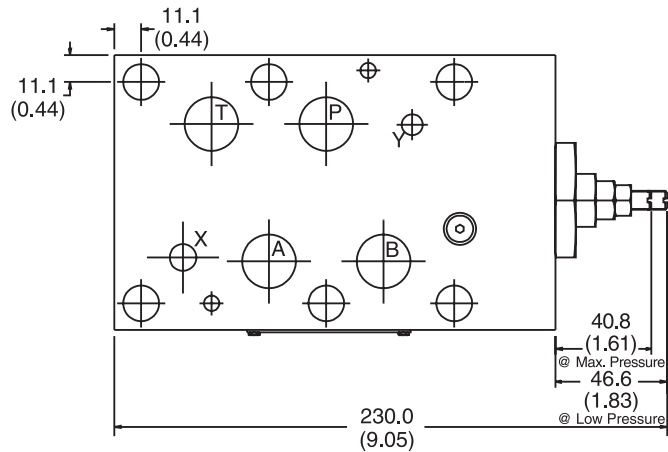

Top View

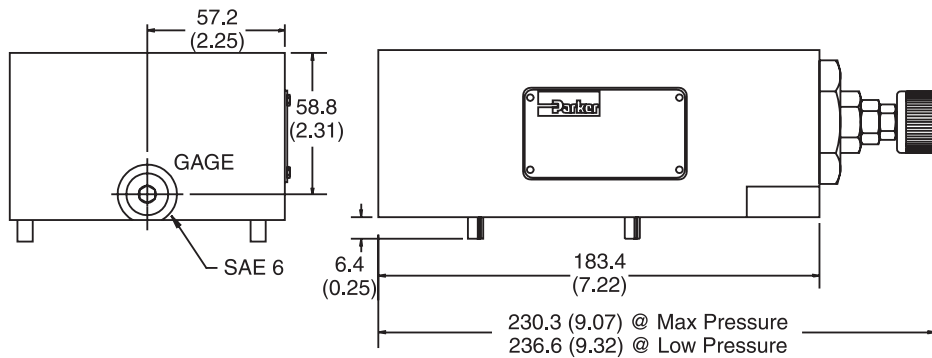

Face View

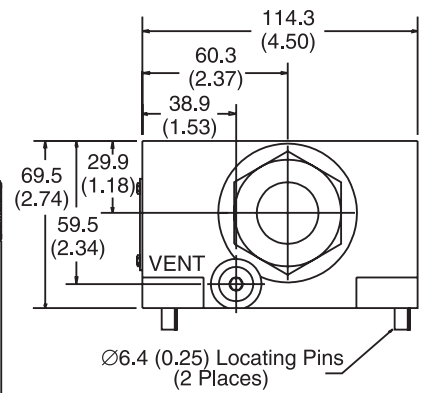

End View

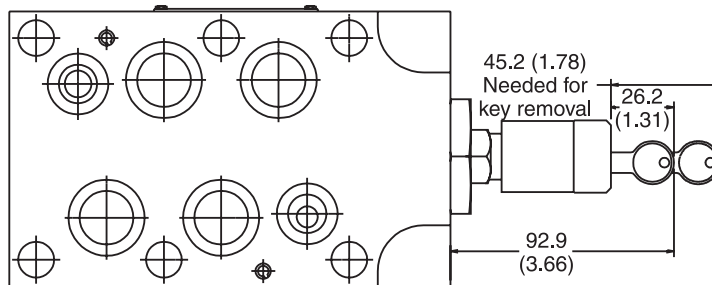

Bottom View

B

