

**General Description**

Series SE20 is a two stage, 4-way, flapper and nozzle style servovalve. The SE20 has a wide range of flow ratings and a high performance spool and sleeve design.

A special jewel feedback design enhances durability and prevents ball glitch problems, which can occur in other types of servovalves. This valve is rated for 315 Bar (4500 PSI) service with an option for 500 Bar (7250 PSI).

**C**

**Features**

- Lapped spool and sleeve
- Jewel feedback ball for durability
- Aluminum body
- Medium and High performance
- ISO 10372 standard 22.23 mm (0.875 in.) port circle

**Specifications**

<b>Flow Rating ±10% @ 70 Bar (1000 PSI)</b>	3.8, 9.5, 19, 38, 63, 75 LPM (1, 2.5, 5, 10, 16.5, 20 GPM)
<b>Supply Pressure</b>	10 – 315 Bar (145 – 4500 PSI) 500 Bar (7250 PSI) Optional
<b>Tank Port Pressure</b>	210 Bar (3000 PSI) Max. < 10 Bar (145 PSI) for best performance
<b>Null Leakage Flow per 70 Bar (1000 PSI)</b>	1.2 – 1.9 LPM (0.3 – 0.5 GPM)
<b>Pilot Flow @ 210 Bar (3000 PSI)</b>	0.4 – 0.7 LPM (0.1 – 0.2 GPM)
<b>Input Command</b>	±40 mA std.
<b>Frequency Response @ 90° phase shift</b>	> 100 Hz (See Performance Curves)
<b>Non-Linearity</b>	≤ 10%
<b>Hysteresis</b>	≤ 3%
<b>Threshold</b>	≤ 0.5%
<b>Null Shift with temperature with pressure</b>	≤ 2% per 55°C (100°F) ≤ 2% per 70 Bar (1000 PSI)
<b>Pressure Gain change in pressure per 1% change in input command</b>	60% typical
<b>Step Response</b>	See graphs
<b>Fluid</b>	Petroleum based Mineral Oil, 10 – 110 cSt at 38°C (100°F)
<b>Fluid Cleanliness</b>	ISO 4406 15/12 or better
<b>Operating Temperature</b>	-30°C to +130°C (-22°F to +266°F)
<b>Protection Class</b>	NEMA 4, IP65

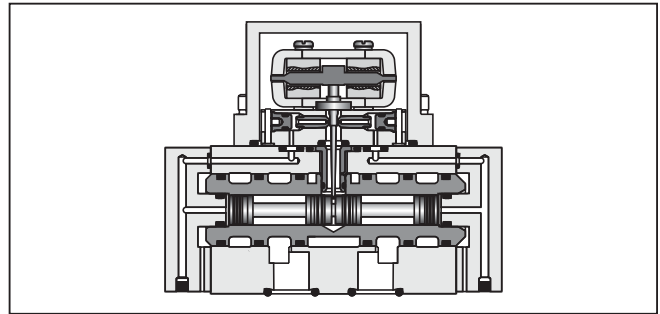
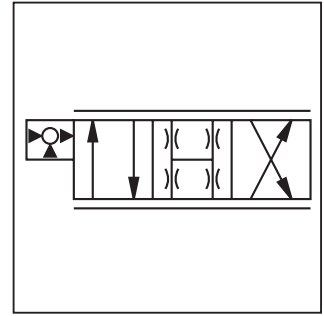

**Flow vs. Pressure Drop**

at 100% command  
Flow Path P →C1 →C2 →R

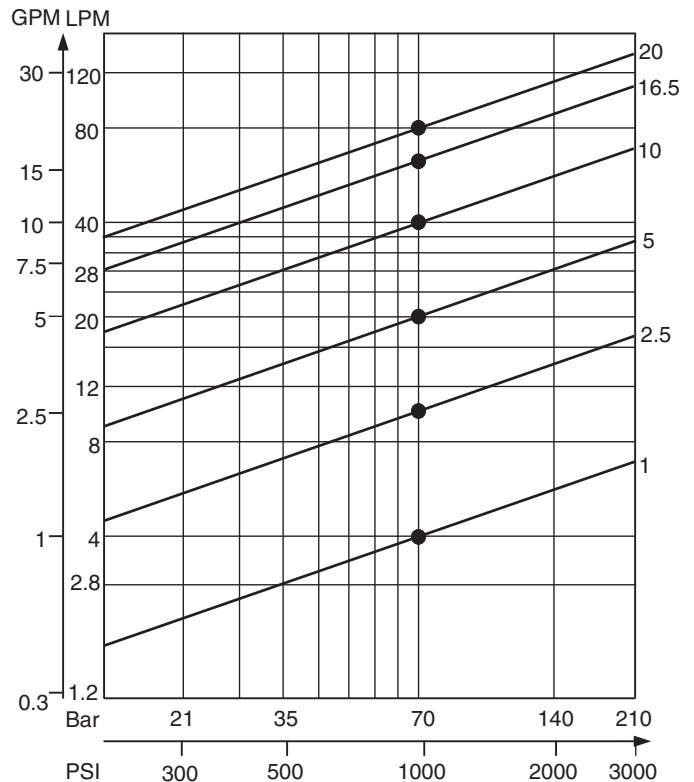

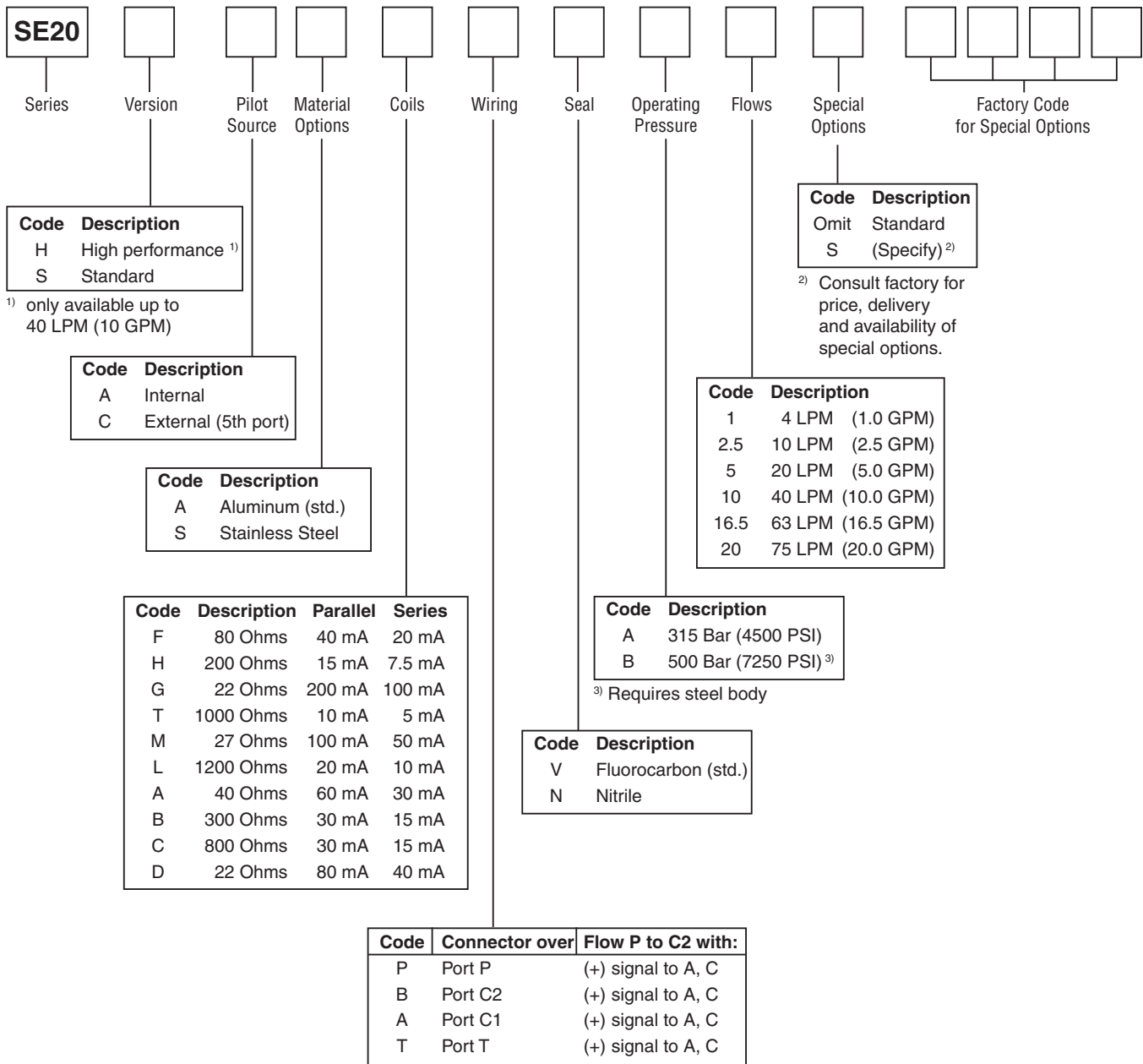

**Weight:** 1.0 kg (2.2 lbs.)  
**Cable with mating connector:** EHC154S  
**Bolt kit:** 4 of M8 x 60 mm, or 4 of 5/16-18x2.25"  
**Flushing valve:** 1200127 (does not cover 5<sup>th</sup> port)  
**U.S. Subplate, 5 ports:** 1402303 (4) #12 SAE side ports, (1) #4 SAE side ports  
**U.S. Subplate, 4 ports:** 810090-3 (4) #12 SAE side ports  
**Metric Subplate, 4 ports:** DS04SPS12M (M27 x 2.0 ISO 6149 side ports)  
**Electronics:** BD101, 23-7030, BD90, or BD95

**Frequency Response at 210 Bar (3000 PSI)**

**Standard Response**  
**SE20 – 4 LPM (1.0 GPM)**

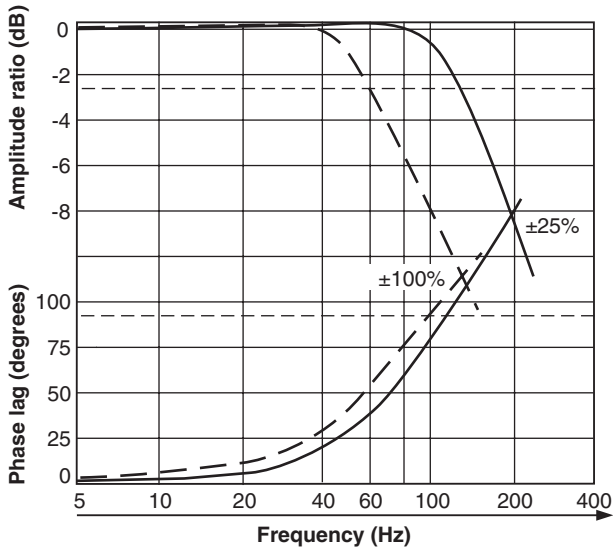

**High Response**  
**SE20 – 4 LPM (1.0 GPM)**

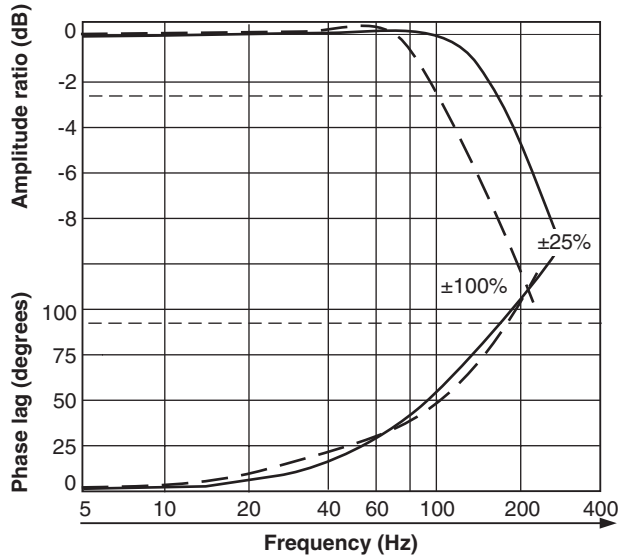

**Standard Response**  
**SE20 – 63 LPM (16.5 GPM)**

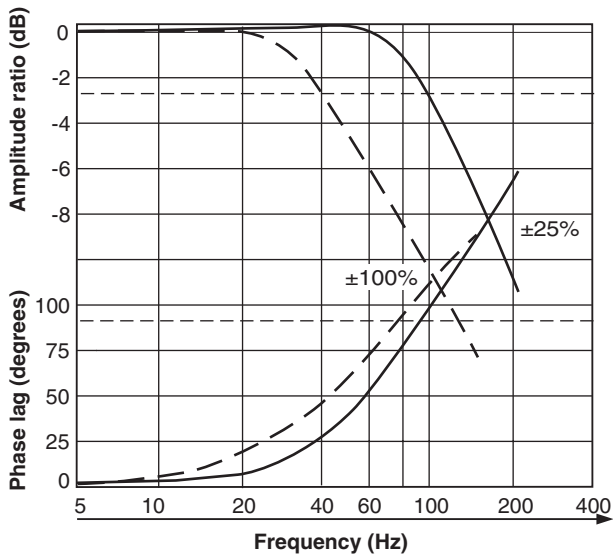

**High Response**  
**SE20 – 40 LPM (10 GPM)**

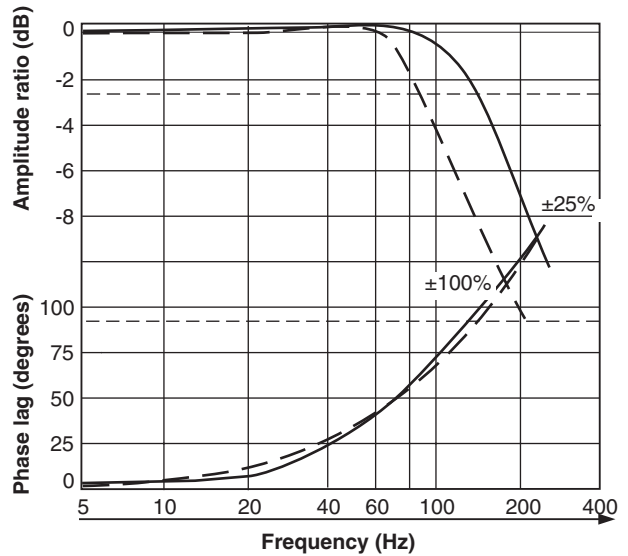

**C**

**Performance Curves**

**Step Response at 210 Bar (3000 PSI)**  
**Standard Response**

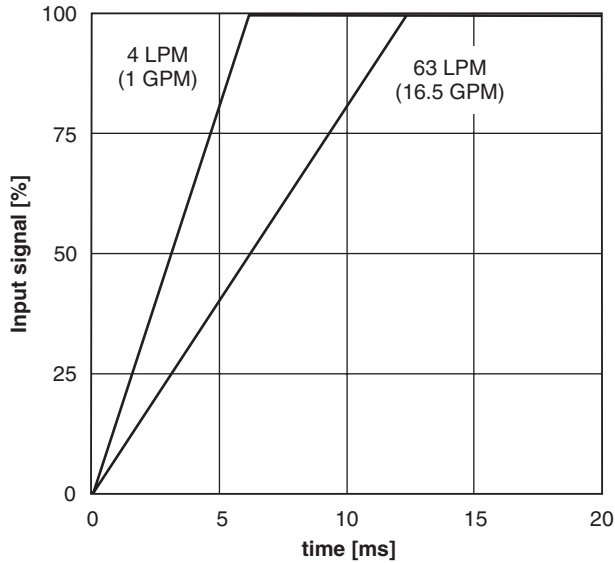

**High Response**

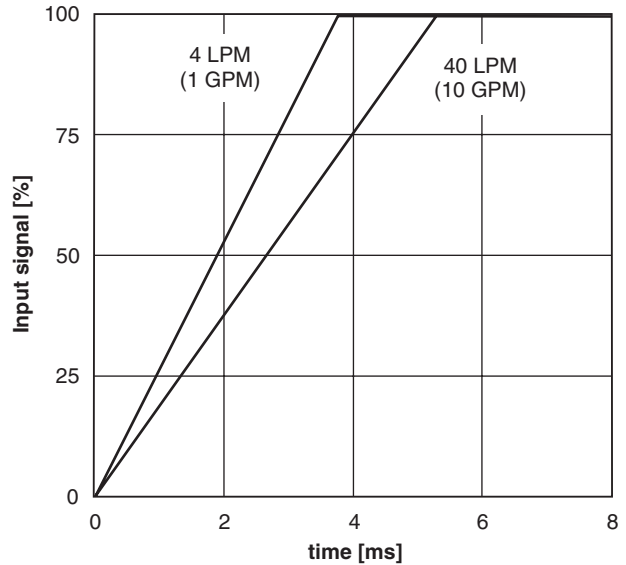

**Installation Wiring Options**

This servovalve has two coils. When connecting the valve to a drive amplifier, the user's external wiring may put the coils either in parallel or in series as needed. Refer to the illustrations below and to the mounting pattern for this valve to insure proper control phasing.

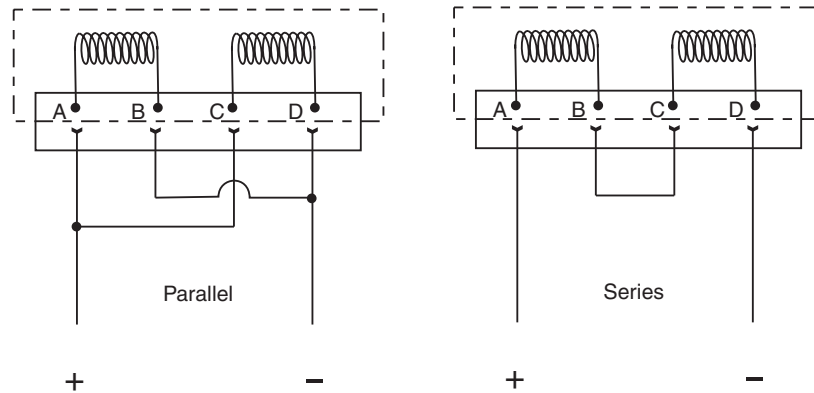

Polarity shown connects flow from P to C2 port.

Inch equivalents for millimeter dimensions are shown in (\*\*)

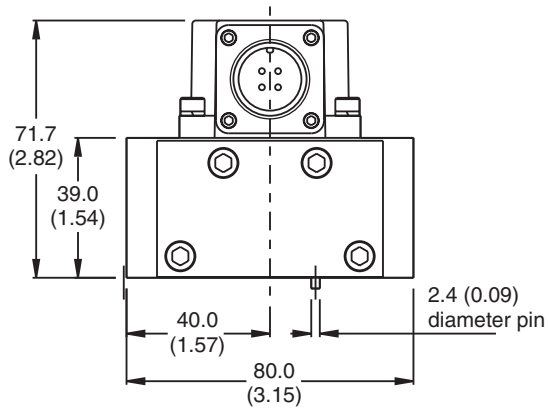
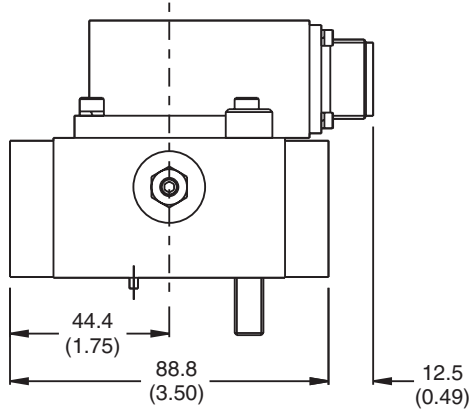

**C**

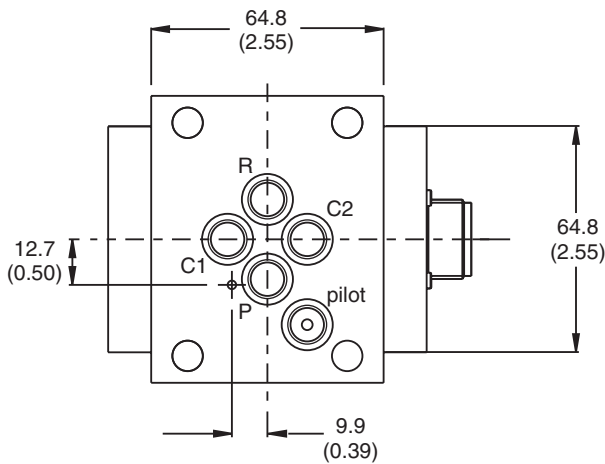

Mounting Torque  
29 Nm (21.4 lb.-ft.)

1. Suggested mounting bolts M8 x 60 mm or 5/16-18 x 2.25" high tensile steel, socket-head cap screws.
2. The 4-way electrical connector mates with MS3106-14S-2S or equivalent. It is available at ±90° and 180° to position shown (advise desired position at time of order).
3. Base O-Rings: 10.82 I/D x 1.78 section (2013N-9 or 2013V-9) 5 pcs.
4. Null adjust requires 10 A/F ring spanner (10 mm box-end wrench) and 2.5 hexagon key. Flow out of C1 will increase with clockwise rotation of key.

**Mounting Surface**

1. The minimum depth of hole G is 2 mm (0.079 in.). The ISO recommended full-thread depth is 22 mm (0.866 in.).
2. Surface roughness Ra < 0.8 μm [N6], as specified in ISO 468 and ISO 1302.
3. Surface flatness: 0.025 mm (0.001 in.) as specified in ISO 1101.

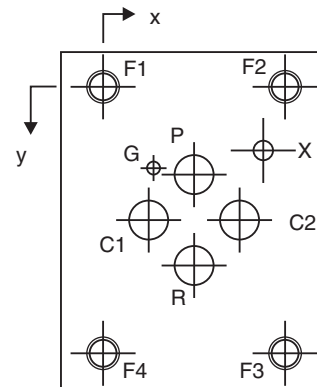

Metric Dimensions (mm)										
(± 0.1 mm)										
Axis	P	C1	R	C2	G	X	F1	F2	F3	F4
	Ø 8.2 max	Ø 8.2 max	Ø 8.2 max	Ø 8.2 max	Ø 3.5	Ø 5	M8	M8	M8	M8
x	22.2	11.1	22.2	33.3	12.3	33.3	0	44.4	44.4	0
y	21.4	32.5	43.6	32.5	19.8	8.7	0	0	65.0	65.0

U.S. Dimensions (inches)										
(± 0.004 in.)										
Axis	P	C1	R	C2	G	X	F1	F2	F3	F4
	Ø 0.32 max.	Ø 0.32 max.	Ø 0.32 max.	Ø 0.32 max.	Ø 0.14 max.	Ø 0.2	5/16 - 18	5/16 - 18	5/16 - 18	5/16 - 18
x	0.875	0.437	0.875	1.311	0.484	1.310	0	1.750	1.750	0
y	0.846	1.280	1.717	1.280	0.780	0.343	0	0	2.562	2.562

SE20.indd, ddp

