



Selection Guidelines

Moldmate couplings are designed for a maximum working pressure of 200 PSI. Most thermoplastic and thermoset heat transfer systems have pumps which provide relatively high flow rates at relatively low pressures. Water and water glycol systems usually have capacities ranging from 10 to 40 gpm, with most from 10 to 15 gpm. Normal medial opening pressures are 20 to 60 PSI for these systems. Heat transfer systems using oil generally operate from 10 to 30 PSI. However, their flow rates are usually much higher, requiring the total volume of oil to be circulated at least once per minute.

The number of hose connections in a single mold system results in a cumulative pressure drop. Please note the Pressure Drop vs. Flow Rate chart provided, to select the appropriate size.

Temperature is another important consideration. Parker moldmate couplings with their standard Silicone seal have a temperature capability of -90° to +400°F. Rapid deterioration of the seal and leakage may result if used beyond these limits.

External conditions of temperature, corrosive atmospheres, and other abnormalities may affect coupling performance and must be considered when selection is made. Consult factory with questions.

Applications

Parker moldmate couplings are specifically designed for connecting coolant lines to molds and dies, on injection molding machinery in the plastics and die casting industries. Moldmate couplings significantly reduce machine downtime by providing fast and easy connection of coolant lines during mold changes. Their short nipples can be recessed below the surface of the mold for more efficient storage of molds. Moldmate couplers are available with or without valves in the female half. Non-valved couplers provide maximum flow for efficient cooling. Valved couplers shut off when disconnected.

Special Order Information

Standard seal material is Silicone and is compatible with water and water glycol fluids commonly used in heat transfer systems. Fluorocarbon seals are available for use only with oil-based media and not with water glycol. To specify a Fluorocarbon seal, add the suffix "Y" to the standard moldmate part number, thus: PC206Y.

Specifications

Body Size (in.)	1/4	3/8	1/2
Rated Pressure (PSI)	200	200	200
Rated Flow (GPM)	3	6	12

Material	Temperature Range
Standard Silicone seal	-90° to +400°F
*Optional Fluorocarbon seal	-15° to +400°F

* For use with oil based media only

Performance

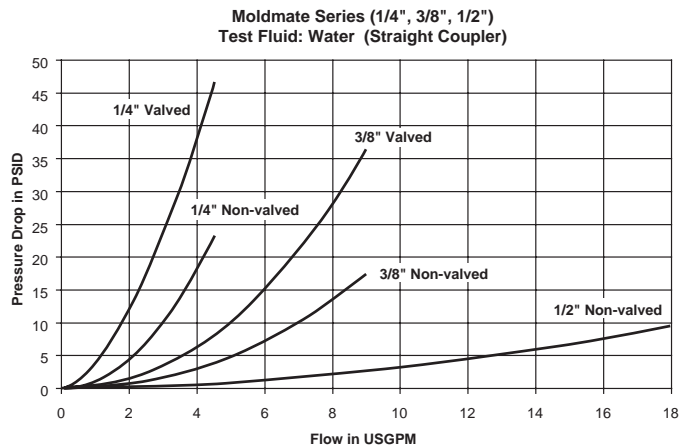

Hydraulic Quick Couplings

Mold Coolant Line Couplings

Moldmate Series

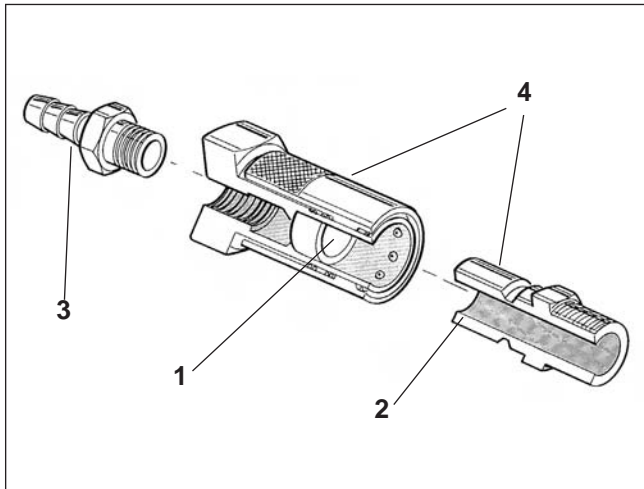

Features

1. Available with or without valves in the coupler. Non-valved couplers have minimum flow resistance for maximum cooling. Valved couplers shut off automatically upon disconnect. Valved couplers can be used with either valved or non-valved nipples. A valved nipple, however, must be used with a valved coupler.
2. Nipples are designed to be recessed below mold surfaces to provide more efficient storage of molds and prevent damage to the nipple.
3. Widest choice of end fittings available, including straight, 45° or 90° with standard hose barb or Push-Lok barbs for easy installation.
4. Couplers and nipples are made of corrosion resistant brass, and valved couplers or valved nipple have a Fluorocarbon O-ring on poppet and Silicone interface seal as standard for use with water glycol type fluids commonly used in heat transfer systems.
5. Silver colored sleeve designates valved coupler.

Couplers

Straight

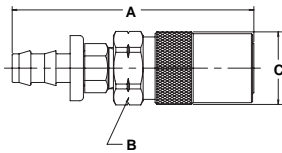

45 Degree

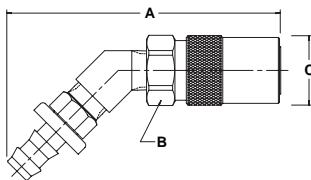

Body Size (in.)	Part No. Brass Non-valved	Wt. (LB.) P/Piece	Part No. Brass Valved	Wt. (LB.) P/Piece	Hose I.d.	Dimensions (in.)					
						Overall Length	Largest Diameter		Overall Length	Hex Largest Size Diameter	
							Non-valved A	C		Valved A	B
1/4	PC204	0.10	PC204AV	0.10	1/4	1.87	0.63	0.63	2.67	0.63	0.71
1/4	PC204-BP*	0.10	PC204AV-BP	0.10	1/4	1.89	0.63	0.63	2.52	0.63	0.71
1/4	PC205	0.09	PC205AV	0.10	5/16	1.87	0.63	0.63	2.67	0.63	0.71
1/4	PC206	0.09	PC206AV	0.10	3/8	1.87	0.63	0.63	2.67	0.63	0.71
1/4	PC206-BP*	0.11	PC206AV-BP	0.13	3/8	2.04	0.63	0.63	2.70	0.63	0.71
3/8	PC306	0.24	PC306V	0.27	3/8	3.01	0.96	0.96	3.17	0.88	1.01
3/8	PC306-BP*	0.26	PC306V-BP	0.29	3/8	3.15	0.96	0.96	3.31	0.88	1.01
3/8	PC308	0.25	PC308V	0.28	1/2	3.15	0.96	0.96	3.17	0.88	1.01
3/8	PC308-BP*	0.25	PC308V-BP	0.03	1/2	3.27	0.96	0.96	3.43	0.88	1.01
1/2	PC504	0.46	NA	-	1/2	3.55	1.30	1.30	-	-	-
1/2	PC504-BP*	0.50	NA	-	1/2	3.68	1.21	1.21	-	-	-
1/2	PC506	0.48	NA	-	3/4	3.80	1.21	1.21	-	-	-
1/2	PC506-BP*	0.52	NA	-	3/4	3.80	1.21	1.21	-	-	-

NA = Not Available

Body Size (in.)	Part No. Brass Non-valved	Wt. (LB.) P/Piece	Part No. Brass Valved	Wt. (LB.) P/Piece	Hose I.D.	Dimensions (in.)					
						Overall Length	Hex Size	Largest Diameter	Overall Length	Hex Size	Largest Diameter
A	B	C	A	B	C						
1/4	PC224	0.13	PC224AV	0.13	1/4	2.67	0.56	0.71	2.87	0.63	0.71
1/4	PC224-BP*	0.13	PC224AV-BP	0.14	1/4	2.57	0.56	0.71	2.77	0.63	0.71
1/4	PC226	0.13	PC226AV	0.14	3/8	2.71	0.56	0.71	2.91	0.63	0.71
1/4	PC226-BP*	0.26	PC226AV-BP	0.17	3/8	2.74	0.56	0.71	2.94	0.63	0.71
3/8	PC326	0.36	PC326V	0.36	3/8	3.65	0.88	0.96	3.65	0.88	1.01
3/8	PC326-BP*	0.34	PC326V-BP	0.36	3/8	3.75	0.88	0.96	3.75	0.88	1.01
3/8	PC328	0.36	PC328V	0.36	1/2	3.69	0.88	0.96	3.69	0.88	1.01
3/8	PC328-BP*	0.34	PC328V-BP	0.40	1/2	3.88	0.88	0.96	3.88	0.88	0.96
1/2	PC524	0.74	NA	-	1/2	4.18	1.12	1.21	-	-	-
1/2	PC524-BP*	0.78	NA	-	1/2	4.28	1.12	1.21	-	-	-
1/2	PC526	0.76	NA	-	3/4	4.56	1.12	1.21	-	-	-
1/2	PC526-BP*	0.80	NA	-	3/4	4.56	1.12	1.21	-	-	-

* Suffix BP in part number denotes Push-Lok hose barb. Without suffix denotes standard hose barb.

Push-Lok hose barbs are designed for use with Parker Push-Lok hose and do not require clamps.

Valved Couplers can be used with either non-valved or valved nipples.

Hydraulic Quick Couplings

Mold Coolant Line Couplings Moldmate Series

90 Degree

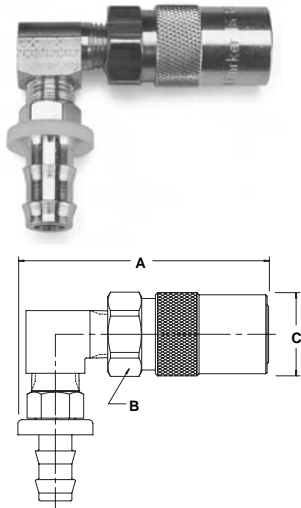

Body Size (in.)	Part No. Brass Non-valved	Wt. (LB.) P/Piece	Part No. Brass Valved	Wt. (LB.) P/Piece	Hose I.D.	Dimension (in.)			Dimensions (in.)		
						Overall Length	Hex Size	Largest Diameter	Overall Length	Hex Size	Largest Diameter
						Non-valved			Valved		
						A	B	C	A	B	C
1/4	PC214	0.13	PC214AV	0.14	1/4	1.78	0.56	0.71	1.98	0.63	0.71
1/4	PC214-BP*	0.14	PC214AV-BP	0.14	1/4	1.78	0.56	0.71	1.98	0.63	0.71
1/4	PC215	0.13	PC215AV	0.14	5/16	1.78	0.56	0.71	1.98	0.63	0.71
1/4	PC216	0.14	PC216AV	0.15	3/8	1.78	0.56	0.71	1.98	0.63	0.71
1/4	PC216-BP*	0.16	PC216AV-BP	0.17	3/8	1.80	0.56	0.71	2.00	0.63	0.71
3/8	PC316	0.31	PC316V	0.31	3/8	2.78	0.88	0.96	2.78	0.88	0.96
3/8	PC316-BP*	0.37	PC316V-BP	0.37	3/8	2.78	0.88	0.96	2.78	0.88	0.96
3/8	PC318	0.33	PC318V	0.35	1/2	2.78	0.88	0.96	2.78	0.88	0.96
3/8	PC318-BP*	0.37	PC318V-BP	0.39	1/2	2.80	0.88	0.96	2.80	0.88	0.96
1/2	PC514	0.79	NA	-	1/2	3.50	1.12	1.21	-	-	-
1/2	PC514-BP*	0.83	NA	-	1/2	3.50	1.12	1.21	-	-	-
1/2	PC516	0.80	NA	-	3/4	3.50	1.12	1.21	-	-	-
1/2	PC516-BP*	0.84	NA	-	3/4	3.50	1.12	1.21	-	-	-

* Suffix BP in part number denotes Push-Lok hose barb. Without suffix denotes standard hose barb. Push-Lok hose barbs are designed for use with Parker Push-Lok hose and do not require clamps. Valved Couplers can be used with either non-valved or valved nipples.

Sub Assemblies and Individual Replacement Parts

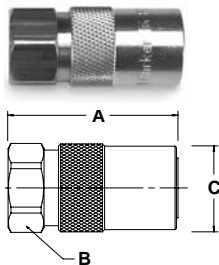

Non-valved Sub-assembly (Brass Sleeve)

Body Size (in.)	Part No. Brass For No-valving	Wt. (LB.) P/Piece	Thread Size NPTF	Dimensions (in.)		
				Overall Length	Hex Size	Largest Diameter
				A	B	C
1/4	P208-01A	0.07	1/8-27	1.15	0.56	0.71
3/8	P308-01A	0.21	1/4-18	1.84	0.88	0.96
3/8	P308-01A-HF	0.20	3/8-18	1.84	0.88	0.96
1/2	PC500	0.34	1/2-14	2.02	1.12	1.21

Valved* Sub-assembly (Silver Colored Sleeve)

Body Size (in.)	Part No. Brass For Valving	Wt. (LB.) P/Piece	Thread Size NPTF	Dimensions (in.)		
				Overall Length	Hex Size	Largest Diameter
				A	B	C
1/4	P201-01A	0.07	1/8-27	1.35	0.56	0.71
3/8	P301-01A	0.21	1/4-18	1.84	0.88	0.96

*Bodies are designed for use with valves retained by a male pipe fitting (i.e. hose barb). Order valves and valve springs separately.



Valves (for Valved Sub-assembly)

Body Size (in.)	Part No.	Material
1/4	3613001	Brass
3/8	P300-11S	Brass

Valve Springs (for Valved Sub-assembly)

Body Size (in.)	Part No.	Material
1/4	7820123	Stainless
3/8	P300-6	Stainless

Replacement Seals (for both Valved and Non-valved)

Seal Material	Body Size (in.) 1/4	Body Size (in.) 3/8	Body Size (in.) 1/2
* Silicone	P200-9A	P300-9A	P500-9A
* Fluorocarbon	P200-9AY	P300-9AY	—

* Please note: Bulk seals are considered to be non-returnable.

Assembly Instruction Sheet (for all sizes & configurations)

Order Part Number 9090065



Hydraulic Quick Couplings

Mold Coolant Line Couplings Moldmate Series

Nipples

Female Pipe Thread

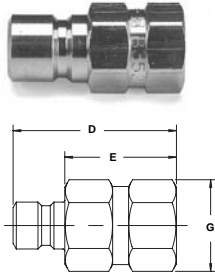

Body Size (in.)	Part No. Brass	Wt. (LB.) P/Piece Brass	Part No. Steel	Wt. (LB.) P/Piece Steel	Thread Size NPTF	Dimensions (in.)			
						Overall Length	**Exposed Length	Hex Size	Largest Diameter
						D	E	F	G
1/4	BPN251F	0.02	PN251F	0.02	1/8-27	0.97	0.58	0.50	0.58
1/4	BPN252F	0.05	PN252F	0.04	1/4-18	1.28	0.89	0.63	0.72
1/4	BPN253F	0.08	PN253F	0.08	3/8-18	1.41	1.02	0.75	0.87
3/8	BPN352F	0.05	PN352F	0.05	1/4-18	1.48	0.88	0.63	0.72
3/8	BPN353F	0.07	PN353F	0.06	3/8-18	1.58	0.98	0.75	0.87

Male Pipe Thread

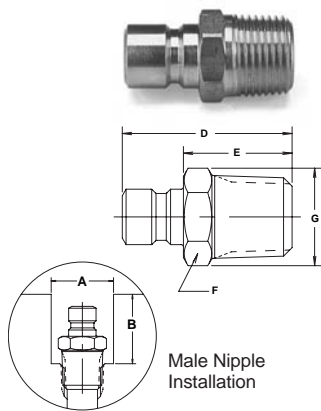

Body Size (in.)	Part No. Brass	Wt. (LB.) P/Piece Brass	Part No. Steel	Wt. (LB.) P/Piece Steel	Thread Size NPTF	Dimensions (in.)				Installation Recess	
						Overall Length	**Exposed Length	Hex Size	Largest Dia.	Dia.	Depth
						D	E	F	G	A	B
1/4	PN250	0.02	-	-	1/16-27	0.94	0.54	0.44	0.51	0.69	0.69
1/4	PN251	0.02	PN251S	0.02	1/8-27	0.94	0.54	0.44	0.51	0.69	0.69
1/4	PN252	0.03	PN252S	0.03	1/4-18	1.13	0.74	0.56	0.67	0.84	0.94
1/4	PN253	0.05	PN253S	0.05	3/8-18	1.19	0.79	0.69	0.79	1.00	0.94
3/8	PN352	0.04	PN352S	0.04	1/4-18	1.34	0.74	0.56	0.65	1.00	1.09
3/8	PN353	0.06	PN353S	0.06	3/8-18	1.38	0.78	0.69	0.79	1.00	1.13
3/8	PN354	0.12	NA	-	1/2-14	1.59	0.99	0.88	1.01	1.19	1.25
1/2	PN553	0.12	NA	-	3/8-18	1.53	0.77	0.88	1.01	1.25	1.34
1/2	PN554	0.11	NA	-	1/2-14	1.70	0.94	0.88	1.01	1.25	1.50
1/2	PN556	0.16	NA	-	3/4-14	1.75	0.99	1.06	1.23	1.50	1.56

Valved Nipple

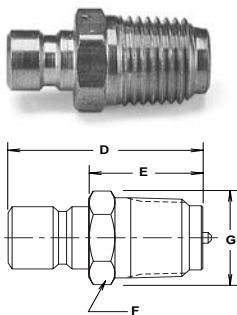

Body Size (in.)	Part No. Brass	Thread Size NPTF	Overall Length	**Exposed Length	Dimensions (in.)			Installation Recess		Wt. (LB.) P/Piece
					Hex Size	Largest Dia.	Dia.	Depth		
			D	E	F	G	A	B		
1/4	BPV252*	1/4-18	1.21	0.82	.56	0.67	0.84	0.94	0.03	
3/8	BPV353*	3/8-18	1.48	0.88	.69	0.79	1.00	1.23	0.07	

*Valved Nipple must be used with Valved Coupler.

**This dimension represents the portion of the nipple that is exposed when inserted into a moldmate coupler.

Moldmate Extension Nipples

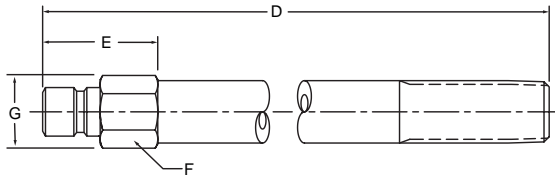

Body Size (in.)	Part No. Brass	Thread Size NPTF	Overall Length	Dimensions (in.)				Wt. (LB.) P/Piece
				D	E	F	G	
1/4	PN250-25	1/16-27	2.50	.69	3/8	0.43	0.04	
1/4	PN250-40	1/16-27	4.00	.81	3/8	0.43	0.06	
1/4	PN250-55	1/16-27	5.50	.81	3/8	0.43	0.09	
1/4	PN251-25	1/8-27	2.50	.69	7/16	0.51	0.06	
1/4	PN251-40	1/8-27	4.00	1.00	7/16	0.51	0.10	
1/4	PN251-55	1/8-27	5.50	1.00	7/16	0.51	0.13	
1/4	PN251-70	1/8-27	7.00	1.00	7/16	0.51	0.17	
1/4	PN251-85	1/8-27	8.50	1.00	7/16	0.51	0.21	
1/4	PN252-25	1/4-18	2.50	.88	9/16	0.65	0.09	
1/4	PN252-40	1/4-18	4.00	1.25	9/16	0.65	0.15	
1/4	PN252-55	1/4-18	5.50	1.25	9/16	0.65	0.22	
1/4	PN252-70	1/4-18	7.00	1.25	9/16	0.65	0.27	
1/4	PN252-85	1/4-18	8.50	1.25	9/16	0.65	0.33	
3/8	PN351-25	1/8-27	2.50	.88	9/16	0.65	0.07	
3/8	PN351-40	1/8-27	4.00	1.00	9/16	0.65	0.11	
3/8	PN351-55	1/8-27	5.50	1.00	9/16	0.65	0.15	
3/8	PN351-70	1/8-27	7.00	1.00	9/16	0.65	0.18	
3/8	PN351-85	1/8-27	8.50	1.00	9/16	0.65	0.22	
3/8	PN352-25	1/4-18	2.50	.88	9/16	0.65	0.09	
3/8	PN352-40	1/4-18	4.00	1.25	9/16	0.65	0.15	
3/8	PN352-55	1/4-18	5.50	1.25	9/16	0.65	0.21	
3/8	PN352-70	1/4-18	7.00	1.25	9/16	0.65	0.27	
3/8	PN352-85	1/4-18	8.50	1.25	9/16	0.65	0.33	
3/8	PN353-25	3/8-18	2.50	1.00	11/16	0.79	0.12	
3/8	PN353-40	3/8-18	4.00	1.25	11/16	0.79	0.20	
3/8	PN353-55	3/8-18	5.50	1.25	11/16	0.79	0.28	
3/8	PN353-70	3/8-18	7.00	1.25	11/16	0.79	0.37	
3/8	PN353-85	3/8-18	8.50	1.25	11/16	0.79	0.45	

B Hydraulics