

MKDSV 5/ 2-6,35

Order No.: 1710056

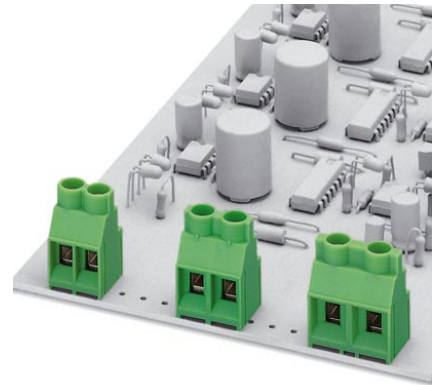

<http://eshop.phoenixcontact.de/phoenix/treeViewClick.do?UID=1710056>

PC terminal block, Nominal current: 32 A, Nom. voltage: 630 V, Pitch: 6.35 mm, Number of positions: 2, Connection method: Screw connection, Color: green, In order to avoid tolerances between the terminal blocks and the printed circuit board, they should be interrupted when the number of positions exceeds 30.

Commercial data

GTIN (EAN)	 4 017918 241537
sales group	E510
Pack	50 pcs.
Customs tariff	85369010
Catalog page information	Page 363 (CC-2011)

Product notes

WEEE/RoHS-compliant since:
01/01/2003



<http://www.download.phoenixcontact.com>
Please note that the data given here has been taken from the online catalog. For comprehensive information and data, please refer to the user documentation. The General Terms and Conditions of Use apply to Internet downloads.

Technical data

Dimensions / positions

Pitch	6.35 mm
Dimension a	6.35 mm
Number of positions	2

Pin dimensions	0,9 x 0,9 mm
Hole diameter	1.3 mm
Screw thread	M3
Tightening torque, min	0.5 Nm

Technical data

Range of articles	MKDSV 5
Insulating material group	I
Rated surge voltage (III/3)	6 kV
Rated surge voltage (III/2)	6 kV
Rated surge voltage (II/2)	6 kV
Rated voltage (III/3)	500 V
Rated voltage (III/2)	630 V
Rated voltage (II/2)	1000 V
Connection in acc. with standard	EN-VDE
Nominal current I_N	32 A
Nominal cross section	4 mm ²
Maximum load current	32 A (with 6 mm ² conductor cross section)
Insulating material	PA
Inflammability class acc. to UL 94	V0
Internal cylindrical gage	A4
Stripping length	8 mm
Nominal voltage, UL/CUL Use Group B	300 V
Nominal current, UL/CUL Use Group B	30 A
Nominal voltage, UL/CUL Use Group D	300 V
Nominal current, UL/CUL Use Group D	10 A

Connection data

Conductor cross section solid min.	0.2 mm ²
Conductor cross section solid max.	6 mm ²
Conductor cross section stranded min.	0.2 mm ²
Conductor cross section stranded max.	4 mm ²
Conductor cross section stranded, with ferrule without plastic sleeve min.	0.25 mm ²
Conductor cross section stranded, with ferrule without plastic sleeve max.	4 mm ²

Conductor cross section stranded, with ferrule with plastic sleeve min.	0.25 mm ²
Conductor cross section stranded, with ferrule with plastic sleeve max.	4 mm ²
Conductor cross section AWG/kcmil min.	24
Conductor cross section AWG/kcmil max	10
2 conductors with same cross section, solid min.	0.2 mm ²
2 conductors with same cross section, solid max.	1.5 mm ²
2 conductors with same cross section, stranded min.	0.2 mm ²
2 conductors with same cross section, stranded max.	1.5 mm ²
2 conductors with same cross section, stranded, ferrules without plastic sleeve, min.	0.25 mm ²
2 conductors with same cross section, stranded, ferrules without plastic sleeve, max.	0.75 mm ²
2 conductors with same cross section, stranded, TWIN ferrules with plastic sleeve, min.	0.5 mm ²
2 conductors with same cross section, stranded, TWIN ferrules with plastic sleeve, max.	2.5 mm ²
Minimum AWG according to UL/CUL	30
Maximum AWG according to UL/CUL	10

Certificates / Approvals



Certification

CUL, GOST, UL

Diagrams/Drawings

Drilling plan/solder pad geometry

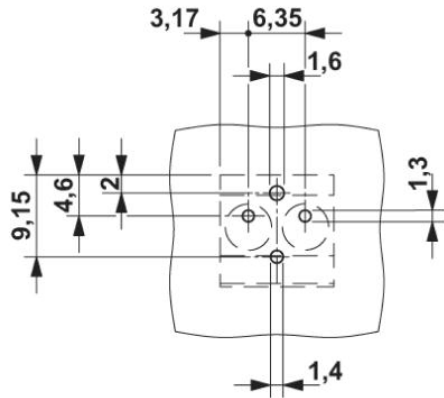

Diagram

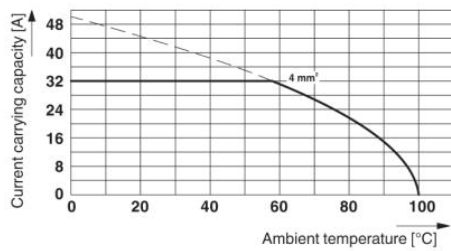

Type: MKDS 5/2-6,35 and MKDS 5/3-6,35
Test following DIN EN 60512-5-2:2003-01
Reduction factor = 1
No. of positions: 5

Dimensioned drawing

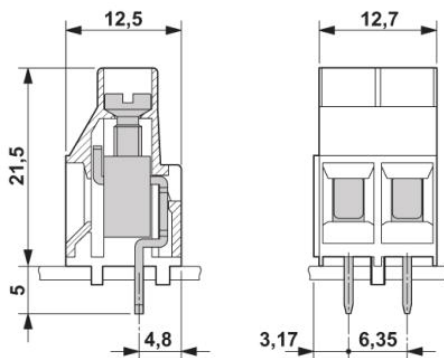

Address

PHOENIX CONTACT Inc., USA
586 Fulling Mill Road
Middletown, PA 17057, USA
Phone (800) 888-7388
Fax (717) 944-1625
<http://www.phoenixcon.com>



© 2011 Phoenix Contact
Technical modifications reserved;