

SUBCON-PLUS M2

Order No.: 2761839

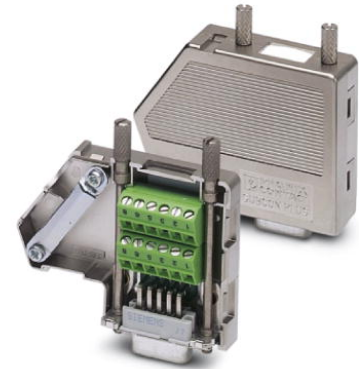

<http://eshop.phoenixcontact.de/phoenix/treeViewClick.do?UID=2761839>

D-SUB connector, 9-pos., male connector, two cable entries < 35°, bus system: CAN, SUCONET K1, K2 (MOELLER), S-BUS (Saia), J-BUS (Merlin Gerin), pin assignment: 2, 3, 4, 5, 7, 9 to two screw connection terminal blocks

RS-485 

Commercial data	
GTIN (EAN)	 4 017918 131814
sales group	H631
Pack	1 pcs.
Customs tariff	85366990
Catalog page information	Page 574 (IF-2011)

Product notes

WEEE/RoHS-compliant since:
06/01/2006



<http://www.download.phoenixcontact.com>
Please note that the data given here has been taken from the online catalog. For comprehensive information and data, please refer to the user documentation. The General Terms and Conditions of Use apply to Internet downloads.

Technical data	
General data	
Nominal voltage U_N	60 V AC/DC
Nominal current I_N	1 A

Bus system	CAN, SUCONET K1, K2 (Moeller), S-BUS (Saia), J-BUS (Merlin Gerin)
Insertion/withdrawal cycles	> 200
Max. cable diameter	10 mm
Min. cable diameter	6 mm
SUBCON fixing screws	4-40 UNC
Tightening torque	0.4 Nm
Ambient temperature (operation)	-20 °C ... 75 °C
Housing material	ABS, metal-plated
Pin assignment	2,3,4,5,7,9 on two terminal blocks
Width	16 mm
Height	44 mm
Length	60 mm

Connection data

Connection	D-SUB connection
Number of positions	9
Connection method	D-SUB connector
Tightening torque	0.4 Nm
Connection	PCB connection
Connection method	Screw connection
Conductor cross section solid min.	0.14 mm ²
Conductor cross section solid max.	1.5 mm ²
Conductor cross section stranded min.	0.14 mm ²
Conductor cross section stranded max.	1 mm ²
Conductor cross section AWG/kcmil min.	26
Conductor cross section AWG/kcmil max	16
Stripping length	5 mm
Tightening torque	0.4 Nm

Certificates / Approvals

Certification

CUL, GOST, UL

Accessories

Item	Designation	Description
------	-------------	-------------

Assembly

2799694	SUBCON-SHORT-SCREW	Optional mounting screw, without knurl for narrow installation conditions, slotted head, length: 40 mm, UNC 4-40 thread
---------	--------------------	---

Diagrams/Drawings

Dimensioned drawing

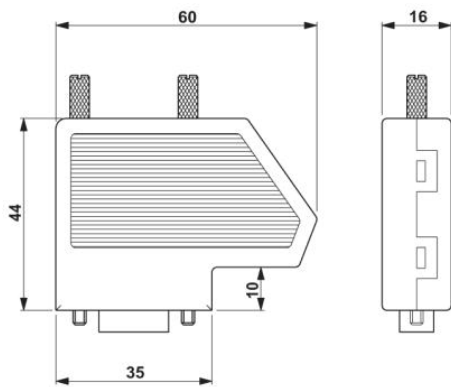

Address

PHOENIX CONTACT Inc., USA
586 Fulling Mill Road
Middletown, PA 17057, USA
Phone (800) 888-7388
Fax (717) 944-1625
<http://www.phoenixcon.com>



© 2011 Phoenix Contact
Technical modifications reserved;