

# CTM 2X1-180DC-GS

Order No.: 2838636



<http://eshop.phoenixcontact.de/phoenix/treeViewClick.do?UID=2838636>

LSA-PLUS protective plug (COMTRAB CTM) with coarse surge protection for 2 signal lines. Nominal voltage: 180 V DC



## Commercial data

GTIN (EAN)	 4 017918 948382
sales group	J460
Pack	10 pcs.
Customs tariff	85363010
Catalog page information	Page 117 (TT-2011)

## Product notes

WEEE/RoHS-compliant since:  
04/12/2006



<http://www.download.phoenixcontact.com>  
Please note that the data given here has been taken from the online catalog. For comprehensive information and data, please refer to the user documentation. The General Terms and Conditions of Use apply to Internet downloads.

## Technical data

### General

Housing material	PA
Inflammability class acc. to UL 94	V0
Color	black

Standards for air and creepage distances	DIN VDE 0110-1
	IEC 60664-1: 1992-10
Surge voltage category	II
Pollution degree	2
Total surge current (8/20) $\mu$ s	10 kA
Total surge current (10/350) $\mu$ s	2.5 kA
Ambient temperature (operation)	-40 °C ... 85 °C
Mounting type	On CT-TERMIBLOCK and LSA-PLUS disconnect strip
Design	LSA-PLUS module
Degree of protection	IP20
Direction of action	Line-Line & Line-Earth Ground
Arrester can be tested with CHECKMASTER from software version:	From SW rev. 2.12
Near-end crosstalk attenuation aN between adjacent articles	70 dB (up to 1 MHz 100 $\Omega$ system)
	50 dB (up to 10 MHz 100 $\Omega$ system)
	30 dB (up to 100 MHz, 100 $\Omega$ system)
Width	9.50 mm
Height	53.50 mm
Length	21.00 mm

**Protective circuit**

IEC category	A2
	B1
	B2
	B3
	C1
	C2
	C3
	D1
	D2

VDE requirement class	A2
	B1
	B2
	B3
	C1
	C2
	C3
	D1
	D2
Nominal voltage $U_N$	180 V DC
Maximum continuous operating voltage $U_C$	$\pm 180$ V DC
Maximum continuous voltage $U_C$ (wire-ground)	$\pm 180$ V DC
Nominal current $I_N$	1.5 A (25°C)
Operating effective current $I_C$ at $U_C$	$\leq 2$ $\mu$ A
Ground conductor current $I_{PE}$	$\leq 2$ $\mu$ A
Nominal discharge surge current $I_n$ (8/20) $\mu$ s (Core-Earth)	5 kA
Total surge current (8/20) $\mu$ s	10 kA
Max. discharge surge current $I_{max}$ (8/20) $\mu$ s maximum (Core-Earth)	10 kA (in total)
Nominal pulse current $I_{an}$ (10/1000) $\mu$ s (Core-Earth)	200 A
Lightning test current (10/350) $\mu$ s, peak value $I_{imp}$	1 kA
Output voltage limitation at 1 kV/ $\mu$ s (Core-Earth) spike	$\leq 800$ V
Output voltage limitation at 1 kV/ $\mu$ s (Core-Earth) static	$\leq 800$ V
Residual voltage at $I_n$ , (conductor-ground)	$\leq 70$ V
Residual voltage with $I_{an}$ (10/1000) $\mu$ s (conductor-ground)	$\leq 28$ V
Protection level $U_P$ (Core-Earth)	$\leq 900$ V (C2, 10 kV/5 kA, spike)
	$\leq 70$ V (C2, 10 kV/5 kA, static)
	$\leq 1$ kV (C3, 7.5 kV/100 A, spike)
	$\leq 30$ V (C3, 7.5 kV/100 A, static)
Response time $t_A$ (Core-Earth)	$\leq 100$ ns
Input attenuation aE, asym.	0.1 dB ( $\leq 10$ MHz)
	0.2 dB ( $\leq 60$ MHz)
	0.5 dB ( $\leq 100$ MHz)

Cut-off frequency fg (3 dB), asym. (PE) in 100 Ohm system	> 100 MHz
Capacity (Core-Earth)	5 pF (f=1 MHz / V <sub>R</sub> = 0 V)
Surge carrying capacity in acc. with IEC 61643-21 (Core-Earth)	C2 (4 kV / 2 kA)
	C3 (100 A)
	B2 (4 kV / 100 A)
	D1 (1 kA)
Alternating current carrying capacity in acc. with IEC 61643-21 (Core-Earth)	5 A - 1 s

#### Connection data

Connection method	can be plugged into COMTRAB-TERMIBLOCK and LSA-PLUS disconnect and switching strips
Connection type IN	COMTRAB plug-in system
Connection type OUT	COMTRAB plug-in system
Connection method	LSA-PLUS

#### Connection, equipotential bonding

Connection method	Spring contact
-------------------	----------------

#### Connection, protective circuit

Standards/regulations	IEC 61643-21
-----------------------	--------------

#### Certificates / Approvals



Certification GOST, UL

#### Additional products

Item	Designation	Description
<b>Assembly</b>		
0441711	CT-TERMIBLOCK 10 DA	Screw termination block with disconnect contacts for accommodating protective plugs CT and CTM. Use in MCR and telecommunications systems. Design: 10 double wires

2839295	SSA 3-6	shield fast connections for conductor diameter 3 - 6 mm. Potential connection cable: 200 mm, black
2839512	SSA 5-10	Shield fast connection for conductor diameters 5 - 10 mm. Potential connection cable: 200 mm, black

**General**

2765547	CT 1-10-ES	Ground rail for CTM protective plug when used in combination with LSA-PLUS disconnect strip. Version: 10 double conductors
2765372	CT 10-MB/ 3	Mounting clip, for holding 3 disconnect or ground wire strips. Version: 10 double conductors, dimensions: A 104.5 mm, B 65 mm.
2765385	CT 10-MB/10	Mounting clip, for holding 10 disconnect or ground wire strips. Version: 10 double conductors, dimensions: A 104.5 mm, dimensions B 245.5 mm
2765356	CT 10-TL	LSA-PLUS disconnect strip to hold the CTM and CT 10 protection modules. Version: 10 double conductors, dimension A: 124 mm.
2765518	CT-KDT	Cable bush for assembly troughs, for protection of the lines guided through the laminated frame
2838610	CTM 10-MAG	Magazine with a grounding rail to accommodate up to 10 LSA-PLUS protective plugs (COMTRAB CTM), to insert in CT-TERMIBLOCK or LSA-PLUS disconnect strip
2838649	CTM EST	LSA-PLUS grounding plug (COMTRAB CTM) to short-circuit and ground potentials in CT-TERMIBLOCK... and disconnect strip CT 10...

**Diagrams/Drawings**

Dimensioned drawing

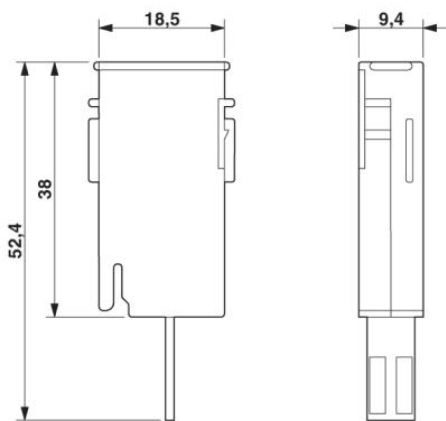

Circuit diagram

---

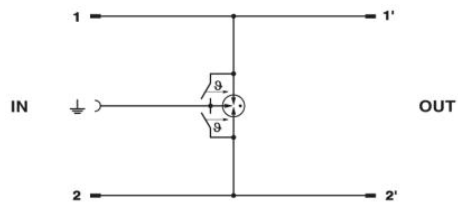

**Address**

PHOENIX CONTACT Inc., USA  
586 Fulling Mill Road  
Middletown, PA 17057, USA  
Phone (800) 888-7388  
Fax (717) 944-1625  
<http://www.phoenixcon.com>



© 2011 Phoenix Contact  
Technical modifications reserved;