

PSR-...- 24DC/FSP/1X1/1X2

SIL coupling relay

Data sheet
104410_en_01

© PHOENIX CONTACT 2013-06-20



1 Description

The **PSR-FSP** SIL coupling relay can be used for power adaptation and electrical isolation in high and low demand applications up to SIL3 according to IEC 61508, EN 61511 as well as EN 50156.

The safety relay is equipped with an enabling current path that drops without delay corresponding to stop category 0 in accordance with DIN EN 60204-1.

By filtering the control controller test pulses, premature failure of the forcibly guided safety relay is prevented.

The load current path is protected by a fuse (5 x 20 mm), which is accessible from the outside .

Features

- SIL3 coupling relay for safety-related switching off
- can be used in high and low demand applications
- Easy proof test according to IEC 61508 due to forcibly guided alarm contact
- Integrated DCS test pulse filter
- Low inrush current
- An undelayed enabling contact
- Replaceable standard fuse (5 x 20 mm)
- Optional plug-in screw or spring-cage terminal blocks

**WARNING: Risk of electric shock**

Observe the safety instructions in the corresponding section.



Make sure you always use the latest documentation.
It can be downloaded from the product at phoenixcontact.net/products.



This data sheet is valid for all products listed on the following page:

2	Table of contents	
1	Description	1
2	Table of contents	2
3	Ordering data	3
4	Technical data	3
5	Basic circuit diagram	6
6	Derating	6
7	Load curve - resistive load	7
8	Load curve - inductive load	7
9	Safety notes	8
10	Pin assignment	9
11	Application examples	10
	11.1 Single-channel connection with integration of the confirmation current path	10
	11.2 Single-channel connection without integration of the confirmation current path	10
12	Proof test	10

3 Ordering data

Description	Type	Order No.	Pcs. / Pkt.
Coupling relay for SIL 3 high/low demand applications, couples digital output signals to the periphery, 1 enabling current path, 1 alarm contact, module for safe state off applications, test pulse filter, fuse, plug-in screw connection, 17.5 mm width	PSR-SCP- 24DC/FSP/1X1/1X2	2981978	1
Coupling relay for SIL 3 high/low demand applications, couples digital output signals to the periphery, 1 enabling current path, 1 alarm contact, module for safe state off applications, test pulse filter, fuse, plug-in spring-cage connection, 17.5 mm width	PSR-SPP- 24DC/FSP/1X1/1X2	2981981	1
Documentation	Type	Order No.	Pcs. / Pkt.
User manual, German, for applications for PSR safety relay	UM DE SAFETY RELAY APPLICATION	2888709	1

4 Technical data

Input data	
Nominal input voltage U_N	24 V DC
Input voltage range (factor)	0.85 ... 1.1
Typical input current	55 mA
Typical inrush current	100 mA
Typical response time	50 ms
Typical release time	50 ms
Recovery time	1 s
Output data	
Contact type	1 undelayed enabling current path 1 undelayed confirmation current path
Contact material	AgCuNi, + 0.2 μ m Au
Minimum switching voltage	15 V AC/DC
Maximum switching voltage	250 V AC/DC
Limiting continuous current	5 A (N/O contact, pay attention to the derating)
Maximum inrush current	5 A
Inrush current, minimum	5 mA
Interrupting rating (ohmic load) max.	120 W (24 V DC, $\tau = 0$ ms, N/C contact: 2.4 W) 144 W (48 V DC, $\tau = 0$ ms, N/C contact: 4.8 W) 66 W (110 V DC, $\tau = 0$ ms, N/C contact: 11 W) 60 W (220 V DC, $\tau = 0$ ms, N/C contact: 22 W) 1250 VA (250 V AC, $\tau = 0$ ms, N/C contact: 25 VA)
Maximum interrupting rating (inductive load)	72 W (24 V DC, $\tau = 40$ ms, N/C contact: 2.4 W) 36 W (48 V DC, $\tau = 40$ ms, N/C contact: 4.8 W) 36 W (110 V DC, $\tau = 40$ ms, N/C contact: 11 W) 48 W (220 V DC, $\tau = 40$ ms, N/C contact: 22 W)
Switching capacity min.	75 mW
Mechanical service life	Approx. 10^7 cycles
Switching capacity (3600/h cycles)	5 A (24 V (DC13)) 5 A (230 V (AC15))
Output fuse	5 A T (Fuse)

General data

Relay type	Electromechanically forcibly guided, dust-proof relay.
Nominal operating mode	100% operating factor
Degree of protection	IP20
Min. degree of protection of inst. location	IP54
Mounting position	Any
Air and creepage distances between the power circuits	DIN EN 50178
Rated surge voltage / insulation	6 kV / Safe isolation, increased insulation

Connection data**Screw connection****Spring-cage conn.**

Conductor cross section, solid	0.2 mm ² ... 2.5 mm ²	0.2 mm ² ... 1.5 mm ²
Conductor cross section, stranded	0.2 mm ² ... 2.5 mm ²	0.2 mm ² ... 1.5 mm ²
Conductor cross section AWG/kcmil	24 ... 12	24 ... 16
Stripping length	7 mm	8 mm

Ambient conditions

Ambient temperature (operation)	-20 °C ... 55 °C
Ambient temperature (storage/transport)	-40 °C ... 80 °C
Max. permissible relative humidity (operation)	75 %
Max. permissible humidity (storage/transport)	≤ 75 % (Condensation and icing are not permitted based on the average annual temperature)
Shock	15 g
Vibration (operation)	2 g

Certification / Approvals

Approvals	
-----------	---

Safety data

Stop category according to IEC 60204	0
--------------------------------------	---

Safety parameters for IEC 61508 - High demand

SIL	3
PFH _d	2.02 x 10 ⁻¹¹
Diagnostic coverage (DC)	99 %
MTTF _d	5656973.3 Years
Demand rate	< 12 Months
Proof test interval	240 Months

The specifications apply assuming the following calculation basis

d _{op}	365 Days
h _{op}	24 h
t _{Cycle}	3600 s

Alternative illustration of the device as 1001 structure for process customers

Equipment type	Type A
HFT	0
SIL	3
Safe Failure Fraction (SFF)	99.99 %
λ _{SD}	198 FIT
λ _{SU}	62.7 FIT
λ _{DD}	3.66 FIT

Alternative illustration of the device as 1001 structure for process customers

λ_{DU}	0.02 FIT
λ_{Total}	264.38 FIT
MTBF	319 Years
PFH	2.02×10^{-11}

Safety parameters for IEC 61508 - Low demand

SIL	3
Diagnostic coverage (DC)	0 %
$MTTF_d$	55203.88 Years
PFD_{avg}	9.87×10^{-5}
Proof test interval	144 Months

Alternative illustration of the device as 1001 structure for process customers

Equipment type	Type A
HFT	0
SIL	3
Safe Failure Fraction (SFF)	99.77 %
λ_{SD}	0 FIT
λ_{SU}	909.7 FIT
λ_{DD}	0 FIT
λ_{DU}	2.09 FIT
λ_{Total}	911.79 FIT
MTBF	113 Years
PFD_{avg}	9.15×10^{-6} (For $T_1 = 1$ year)

Safety characteristic data according to EN ISO 13849

Category	4
Performance level	e
DC_{avg}	99 %
$MTTF_d$	1140.2 Years
CCF	Passed
d_{op}	365 Days
h_{op}	24 h
t_{Cycle}	3600 s

5 Basic circuit diagram

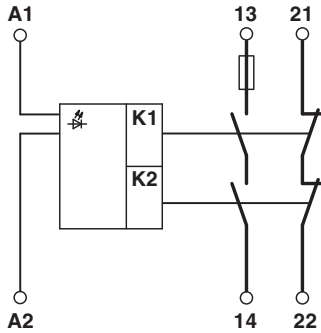

Figure 1 Block diagram

Designation	Explanation
A1/A2	Safety relay input voltage
13/14	Load current path
21/22	Confirmation path

6 Derating

horizontal installation



Figure 2 Derating curve

vertical installation

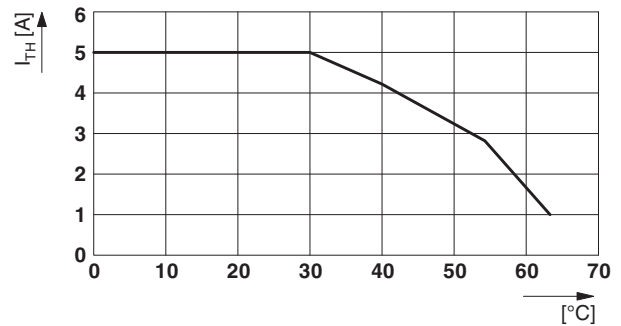

Figure 3 Block diagram

7 Load curve - resistive load

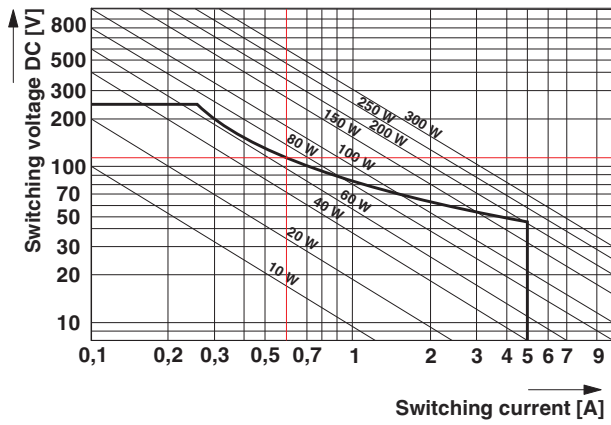

Figure 4 resistive load

8 Load curve - inductive load

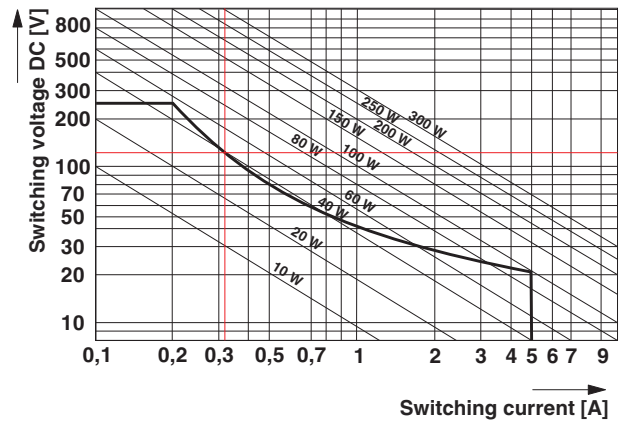

Figure 5 inductive load

9 Safety notes



WARNING: Risk of electric shock

During operation, parts of electrical switching devices carry hazardous voltages.

Before working on the switching device, disconnect the power.

Please observe the safety regulations of electrical engineering and industrial safety and liability associations.

Disregarding these safety regulations may result in death, serious personal injury or damage to equipment.

Startup, mounting, modifications, and upgrades should only be carried out by a skilled electrical engineer!



WARNING: Risk of automatic machine restart!

For emergency stop applications, the machine must be prevented from restarting automatically by a higher-level control system.

Protective covers must not be removed when operating electrical switching devices.



WARNING: Danger due to faulty devices!

The devices may be damaged following an error and correct operation can no longer be ensured.

In the event of an error, replace the device immediately.

Repairs to the device, especially if the housing must be opened, may only be carried out by the manufacturer or authorized persons. Otherwise the warranty is invalidated.



NOTE: Risk of damage to equipment due to incorrect installation

For reliable operation, the safety relay must be installed in housing protected from dust and humidity (IP54).

Carry out wiring according to the application. Refer to the "Application examples" section for this.



NOTE: Risk of damage to equipment due to noise emissions

When operating relay modules the operator must meet the requirements for noise emission for electrical and electronic equipment (EN 61000-6-4) on the contact side and, if required, take appropriate measures.



NOTE: Module damage due to polarity reversal

Polarity reversal places a burden on the electronics and can damage the module.

With resistance monitoring, an error is indicated to the higher-level controller.

Always connect the supply voltage as follows:

A1 to + 24 V

A2 to GND

10 Pin assignment

Operating and indication element

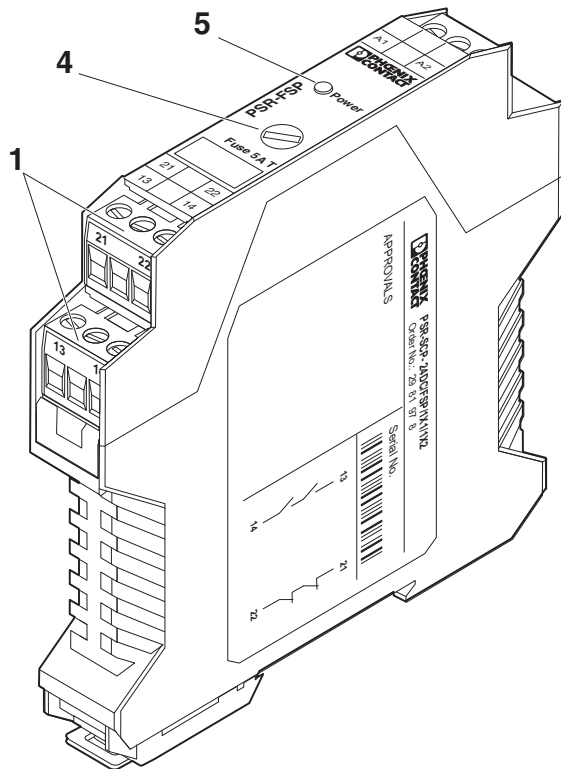

Figure 6 PSR-SCP- 24DC/FSP/1X1/1X2

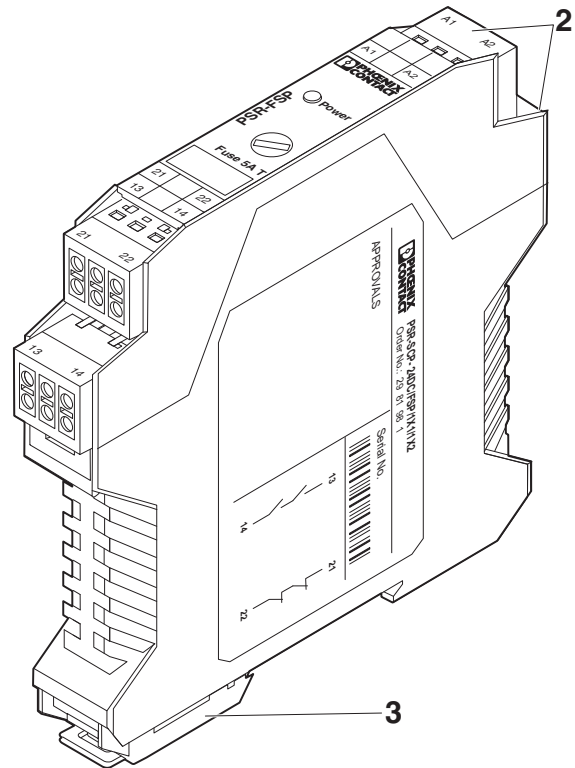

Figure 7 PSR-SPP- 24DC/FSP/1X1/1X2

Designation	Explanation
1	COMBICON plug-in screw terminal blocks
2	COMBICON plug-in spring-cage terminal blocks
3	Metal lock for mounting on the DIN rail
4	Replaceable standard 5 A fuse (5 x 20 mm)
5	LED status indicator, green - Power

11 Application examples

11.1 Single-channel connection with integration of the confirmation current path

Suitable for high demand applications up to safety category 4/PLe, SIL3/SILCL3 (with fault elimination).

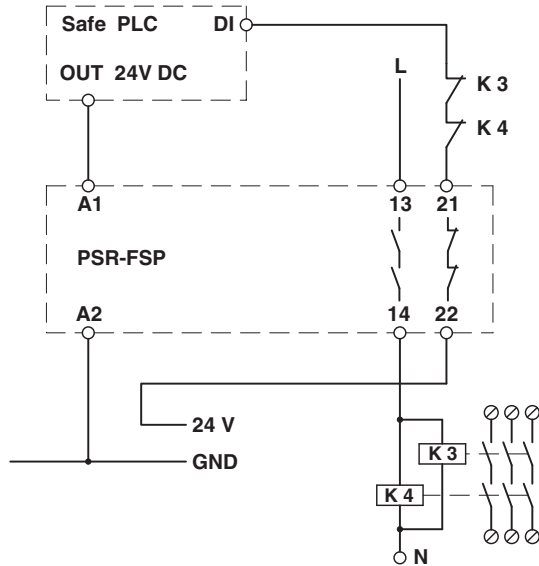

11.2 Single-channel connection without integration of the confirmation current path

Suitable for low demand applications up to safety category SIL3.

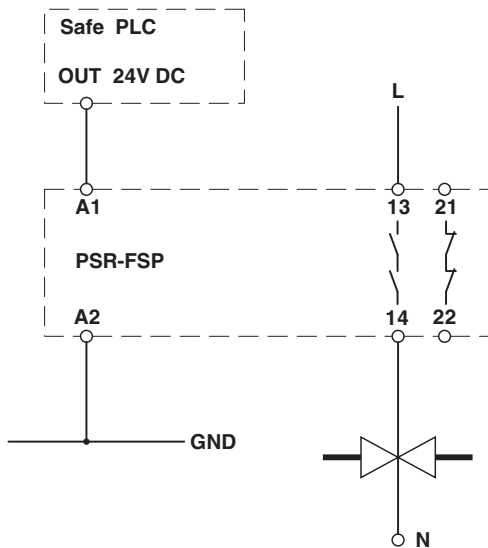

12 Proof test

To verify that the relay is operating correctly, reset it and perform a continuity test for confirmation current path (connection terminal blocks 21/22).



NOTE: Malfunction

In the event of a faulty continuity test, correct function of the emergency stop coupling relay is no longer possible.

The emergency stop coupling relay must be replaced immediately.