

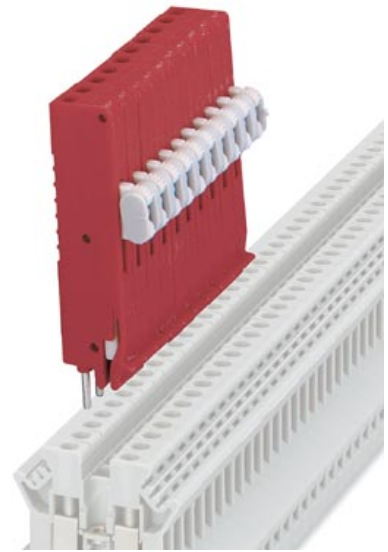

PS-UK 2,5 B/Z-6

Order No.: 3001239



<http://eshop.phoenixcontact.de/phoenix/treeViewClick.do?UID=3001239>

Test plugs, Color: red

Commercial data	
GTIN (EAN)	 4 017918 089856
sales group	A913
Pack	1 pcs.
Customs tariff	85366990
Catalog page information	Page 543 (CL1-2011)

Product notesWEEE/RoHS-compliant since:
01/01/2003

<http://www.download.phoenixcontact.com>
Please note that the data given here has been taken from the online catalog. For comprehensive information and data, please refer to the user documentation. The General Terms and Conditions of Use apply to Internet downloads.

Diagrams/Drawings

Dimensioned drawing

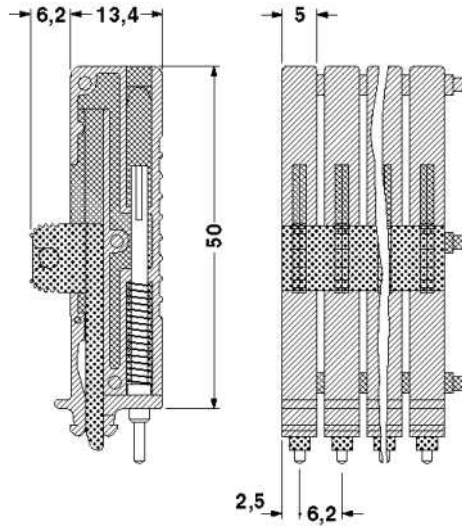

Address

PHOENIX CONTACT Inc., USA
586 Fulling Mill Road
Middletown, PA 17057, USA
Phone (800) 888-7388
Fax (717) 944-1625
<http://www.phoenixcon.com>



© 2011 Phoenix Contact
Technical modifications reserved;