

HAND PUMPS

Part Number	Pressure Rating (psi)		Usable Oil Capacity (in3)	Reservoir Capacity (in3)	Oil Volume/Stroke (in3)		Reservoir Construction	Use with Cylinder	Weight (lbs.)
	1st Stage	2nd Stage			1st Stage	2nd Stage			
P21L	200	10,000	21	31	0.79	0.10	aluminum	S/A	5.1
P37		10,000	34	46	0.79	0.17	steel	S/A	17
P43	-	10,000	39	52	-	0.20	steel	S/A	17
P61L	200	10,000	46	61	0.79	0.10	aluminum	S/A	9.1
P122		10,000	110	128	0.79	0.17	steel	S/A	28
P122DL		10,000	99	122	0.79	0.14	aluminum	D/A	16
P122HF	400	10,000	122	153	2.4	0.17	steel	S/A	26
P213		10,000	213	213	1.8	0.20	steel	S/A	36
P427		10,000	427	427	6.89	0.24	aluminum	S/A	55
P427D		10,000	427	427	6.89	0.24	aluminum	D/A	60



P43



P61L



P122



P122DL



P427



P427D

DESCRIPTION

- Rugged steel or aluminum alloy body construction and low handle efforts.
- Both single and two speed models available for single and double acting cylinders.
- Connect to double acting cylinders with no need for additional control valve or adapters needed.
- Pressure relief valves for overload protection.
- Load release valve for single acting cylinder usage.

Hand Pumps

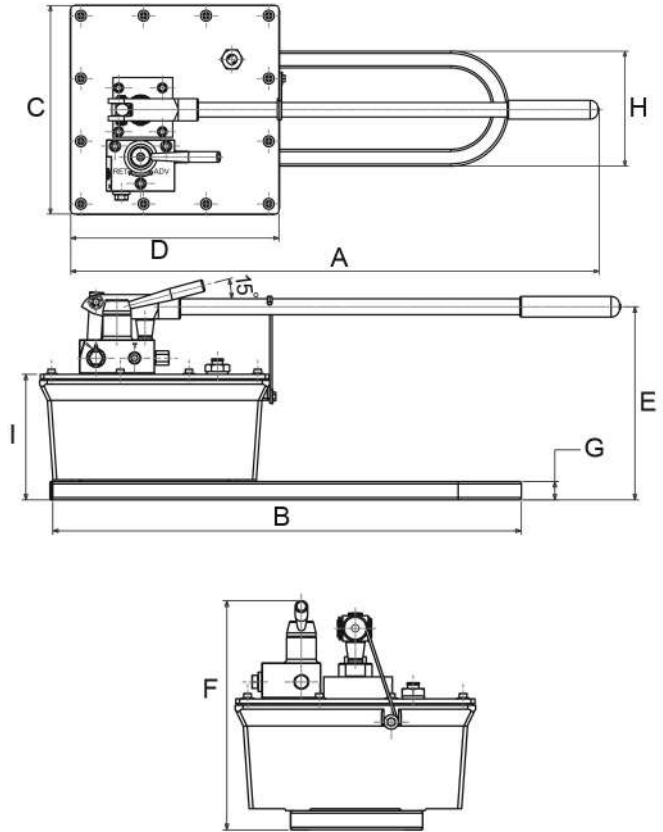
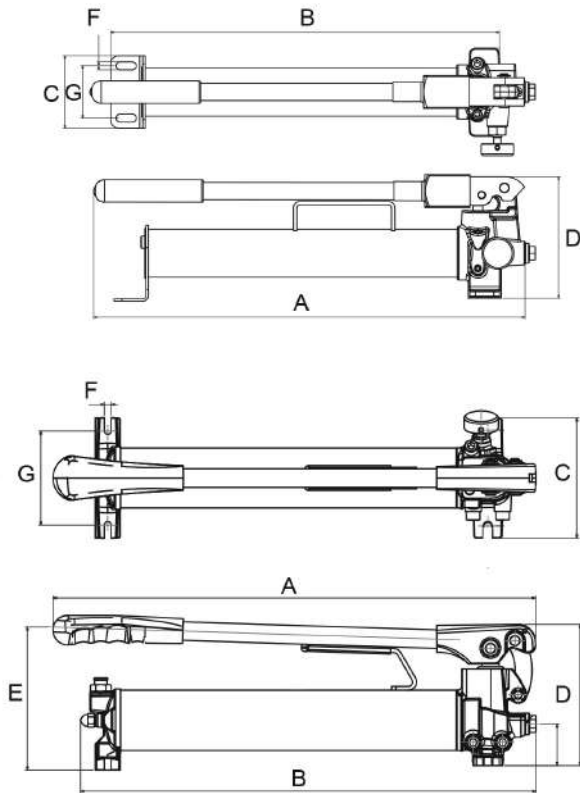

Part Number	A (In.)	B (In.)	C (In.)	D (In.)	E (In.)	F (In.)	G (In.)	H (In.)	I (In.)
P21L	15.40	14.21	4.81	4.99	5.11	N/A	N/A	N/A	N/A
P37	21.32	20.28	5.92	5.81	5.59	N/A	N/A	N/A	N/A
P43	25.12	21.91	5.93	5.81	5.66	N/A	N/A	N/A	N/A
P61L	21.21	19.70	4.81	5.00	5.13	N/A	N/A	N/A	N/A
P122	23.00	21.60	5.80	6.63	7.60	0.41	4.00	N/A	N/A
P122DL	24.00	22.80	5.60	5.30	5.30	N/A	N/A	N/A	N/A
P122HF	24.92	22.26	5.91	7.68	8.74	0.31	4.80	N/A	N/A
P213	24.90	20.80	5.70	6.80	7.40	0.40	3.20	N/A	N/A
P427	30.98	25.00	12.20	12.20	10.28	11.73	0.98	6.73	6.69
P427D	30.98	25.00	12.20	12.20	10.28	11.73	0.98	6.73	6.69