

KITS AND PARTS

#	Kit	Description	Parts
1	KIT120BD*	BioDiesel Kit*	O-ring seal, bypass valve poppet, bypass cap seal, inlet seal
2	KIT120RG	Rotor & Vane Kit	Rotor cover, rotor, vanes, rotor key, O-ring seal, attaching hardware
3	KIT120JCH	Junction Cover Kit	Junction cover, seal, fasteners
4	KIT120SL	Seal Kit	O-ring, shaft seals, retainer clip
5	KIT120BV†	Bypass Service Kit†	Bypass valve, valve spring, bypass cap, O-ring seal
6	KIT120NB	Nozzle Boot Kit	Nozzle boot, attaching hardware
7	KIT120BG	Inlet Flange Kit	Inlet flange (bung), attaching hardware, inlet seal, screen
8	KIT120SG	Inlet Gasket and Screen	Gasket for inlet (bung) and screen
9	KIT120SWH	Switch Lever Kit	Switch lever, mounting hardware

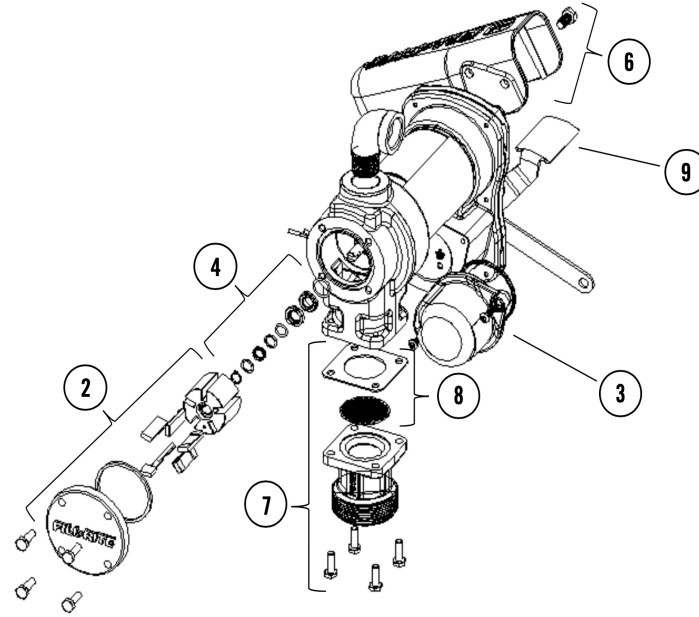

*KIT120BD and †KIT120BV not called out in diagram to the side.

ADDITIONAL INFORMATION



ONLINE

Visit fillrite.com to locate your comprehensive Owner's Installation and Operation Manual, which contains additional information including Operating Instructions, Safety Instructions, Troubleshooting, Technical Information, and Safety Testing Information.



OR CALL

Customer Service at (800) 634-2695 (M-F 8 AM–6 PM ET).

FILL-RITE®
PROUDLY MANUFACTURED BY TUTHILL

H-SERIES FUEL TRANSFER PUMP PRODUCT INSTRUCTION SHEET

For Models FR1200, FR2400, FR4200, FR4400, FR600, SD1200, and SD600

Thank you for your loyalty to the Fill-Rite® brand of fuel transfer pumps.

This installation guide is not a substitute for reading the comprehensive Owner's Installation and Operation Manual that can be found online at fillrite.com.

For your safety and proper operation of your Fill-Rite pump, please refer to the Owner's Manual before installation and adhere to all safety standards, warnings, and precautions.

Gracias por su lealtad a la marca de bombas de transferencia de combustible Fill-Rite®.

Esta guía de instalación no sustituye la completa lectura del Manual de Instalación y Operación del Propietario que se puede encontrar en Español en línea en fillrite.com.

Para su seguridad y el funcionamiento adecuado de su bomba Fill-Rite, por favor consulte el Manual del Propietario en Español antes de la instalación, y cumpla con todos los estándares de seguridad, advertencias y precauciones.

Merci de votre fidélité envers les pompes de transfert de carburant de marque Fill-Rite®.

Ce guide d'installation ne remplace pas la lecture complète du manuel d'installation et d'utilisation du propriétaire en français, qui est disponible en ligne au fillrite.com.

Pour votre sécurité et le bon fonctionnement de votre pompe Fill-Rite, veuillez vous référer au manuel du propriétaire en français avant l'installation. Assurez-vous de respecter toutes les normes de sécurité, les avertissements et les précautions.

FIL-MN-689



BASIC INSTALLATION INSTRUCTIONS



Failure to read and follow the Owner's Installation and Operation Manual instructions may result in serious

personal injury or even death. Mechanical damage and other property damage may also occur. For the safe and proper operation of your Fill-Rite pump, please reference the comprehensive Owner's Manual online before installation and adhere to all safety standards, warnings, and precautions.

STEP 1 (OPTIONAL)

Inlet Flange Removal

Loosen (4) 1/4" bolts with 7/16" wrench or socket. Detach inlet bung from pump, retain bolts, screen, and gasket.

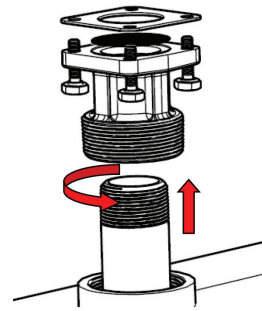

STEP 2

Using either included suction pipe or custom pipe, thread pipe into inlet bung 1.5 to 2.5 turns past hand tight with pipe wrench. Use appropriate sealant for fuel transfer.

If using custom pipe, refer to the Owner's Manual online.

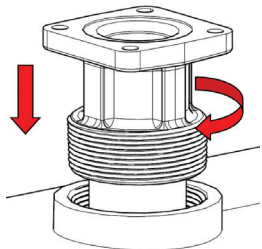

STEP 3

Thread inlet bung with attached suction pipe onto tank 1.5 to 2.5 turns past hand tight. Use appropriate sealant for fuel transfer.

NOTICE!

Maintain a minimum 1-2" separation from pipe end to bottom of tank.

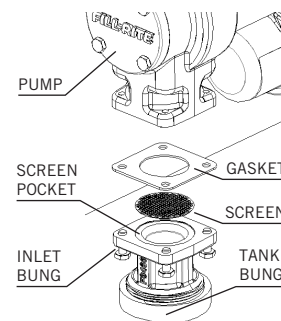

STEP 4 (IF STEP 1 UTILIZED)

Place screen within inlet bung pocket, mount gasket then place pump on tank bung. Align holes and insert (4) 1/4" bolt and tighten with 7/16" wrench to 40 in. lbs. minimum.

ELECTRICAL WIRING INSTRUCTIONS



Electrical wiring should be performed ONLY by a licensed electrician in compliance with local, state, and national electrical code NEC/ANSI/NFPA 70, NFPA 30, and NFPA 30A, as appropriate to the intended use of the pump. Threaded rigid conduit, sealed fittings, and conductor seal should be used where applicable. The pump must be properly grounded. Improper installation or use of this pump can result in serious personal injury or death!

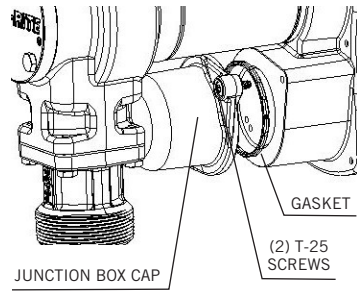

STEP 5

Remove junction box cover via (2) T-25 screws and locate wires. DC Voltage: 2-wires, Black and Red; AC Voltage: 3-wires, Black, Red, and Green that is attached to internal ground screw. Ensure that gasket remains in place upon re-attachment of junction box.

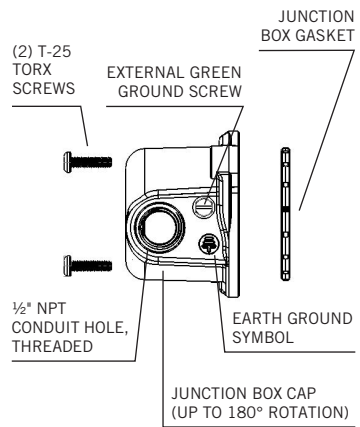

STEP 6

Feed wires from power source through NPT opening into junction box. For DC models, use the black cable connector*. For AC models, attach conduit directly to NPT** opening.

*Black cable connector only included with DC models
**1/2" NPT to cable gland, bronze fitting per ATEX on HE Models

FOR 12V OR 24V DC MODELS ONLY



The pump needs to operate at the rated nameplate voltage. Where applicable, use the electrical cable (included with most 12V or 24VDC models) to supply the appropriate voltage. Utilization of an in-line fuse is recommended to protect against electrical shorts. **A 30 amp fuse is needed for 12VDC and a 20 amp fuse is needed for 24VDC circuits (neither is provided with pump packages).**

Properly ground the pump by connecting the eyelet to the green bonding screw next to the junction box. Then, strip the green wire end and connect to an appropriate location on the vehicle/trailer frame or a grounding rod if on a stationary tank.

... continued onto next page

FOR 12V OR 24V DC MODELS ONLY (CONT.)

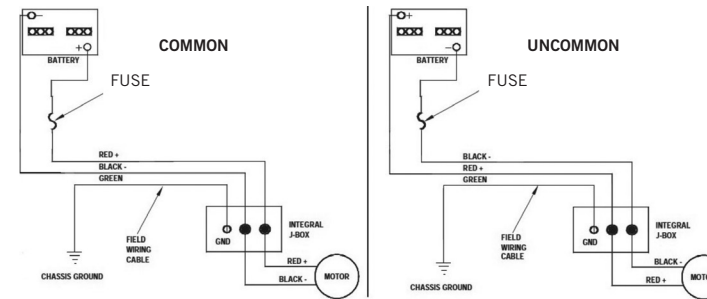

NEGATIVE GROUND SYSTEM

Fuse to be located outside of hazardous area, as close to the power source as possible. If the wiring from the power source to the pump is greater than 20', refer to the applicable Electrical Code (National, International, or local) to ensure the wire is of the correct size for the application.

POSITIVE GROUND SYSTEM

Fuse to be located outside of hazardous area, as close to the power source as possible. If the wiring from the power source to the pump is greater than 20', refer to the applicable Electrical Code (National, International, or local) to ensure the wire is of the correct size for the application.

Identify if power source uses a positive or negative grounding system and follow the appropriate diagram above. With the supplied wiring nuts, attach the red wire from the motor to the positive wire of power source and attach the black wire from the motor to the negative wire of power source. **To determine grounding type, look at the battery and determine whether the positive or negative terminal has a cable connected to the frame/chassis of the vehicle.**

FOR 115V AC MODELS ONLY



All pumps should operate at 115VAC. AC power should be supplied to the pump from a dedicated circuit with 15 amp circuit

protection. No other equipment should be powered by this circuit. Wiring must be of sufficient size to carry the correct current for the pump **refer to wire sizing table within the Owner's Installation and Operation Manual at fillrite.com**. Voltage drop will vary with distance to pump and size of wire; refer to the National Electrical Code (NEC), or local codes, for voltage drop compensation to be sure you are using the correct size wire for your application.

A green earth ground wire is factory installed on 115VAC pumps. Please ensure that the fuel transfer pump is properly grounded to the electrical supply line.

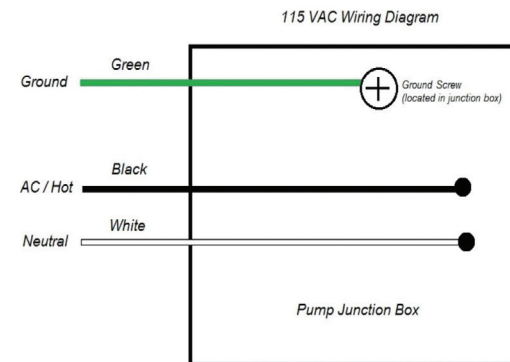

With the supplied wiring nuts, attach the black wire from the motor to the AC/Hot/Black wire of power source and attach the white wire from the motor to the Neutral/White wire of power source.

FOR 115V AC MODELS ONLY (CONT.)

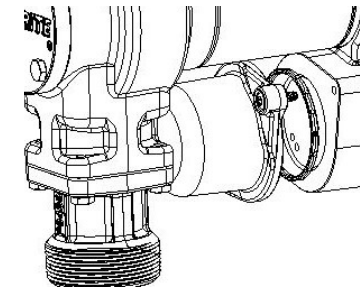

STEP 7 - 115VAC MODELS ONLY

Complete electrical wiring by reattaching the junction box cover by tightening Torx(r) screw with a T-25 wrench to 48 in. lbs., being careful to ensure the junction box gasket is properly seated to prevent moisture from entering the junction box.

BASIC OPERATING INSTRUCTIONS

1. If equipped, reset meter to "0".
2. Remove dispensing nozzle from nozzle boot.
3. Move switch lever to the "ON" position.

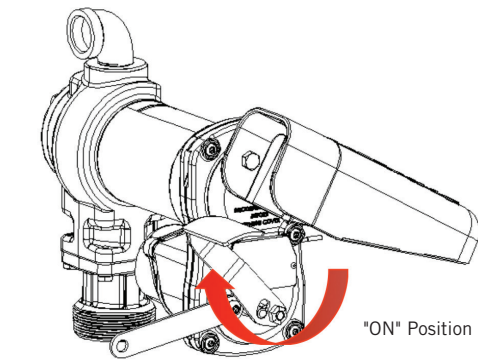

4. Place nozzle into container to be filled.
5. Squeeze nozzle to dispense fluid; release nozzle once desired amount of fluid has been dispensed.
6. Move switch lever to the "OFF" position to turn off pump.

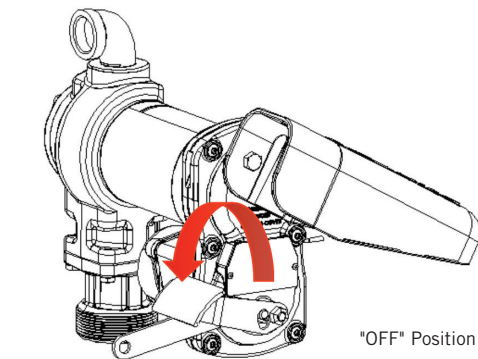

7. Return nozzle from the container to the nozzle boot.

ADDITIONAL INSTALLATION INSTRUCTIONS

For meter and accessory installation, such as hoses, nozzles, swivels, breakaways, or filters and filter heads, please refer the comprehensive Owner's Installation and Operation Manual found online at fillrite.com.