



INSTALLATION INSTRUCTIONS E200 & E100 SERIES FILTER ELEMENTS

(FOR F200 & F100 SERIES FILTERS- ALL GRADES)

PRODUCT PURPOSE & FUNCTION:

Van Air's E200 & E100 series filter elements provide long service life as well as ease of maintenance. With push on style elements, there are no tie rods, gaskets, nuts and bolts. Both the particulate and coalescing elements will operate efficiently for extended periods of time until a pressure drop of 10 PSID has occurred. Our differential pressure indicators and gauges can visually alert when element changeout is needed. The activated carbon elements (RD grade) must be changed to suit specific applications, or at least every 6 months.

FILTER DETAILS		FLOW DIRECTION THROUGH ELEMENT		
		IN/OUT (COALESCING) 	OUT/IN (PARTICULATE) 	
		FILTRATION GRADES		
ELEMENT GRADE	PURPOSE	NOMINAL PARTICULATE REMOVAL	ELEMENT FLOW DIRECTION	ENDCAP COLOR CODE
AA	Extra Coarse Coalescing	25.00μ	IN/OUT	BLACK
A	Coarse Coalescing	5.00μ	IN/OUT	GREEN
B	General Purpose Coalescing	1.00μ	IN/OUT	RED
C	High Efficiency Coalescing	0.01μ	IN/OUT	BLUE
RAA	Extra Coarse Particulate	25.00μ	OUT/IN	BLACK
RA	Coarse Particulate	5.00μ	OUT/IN	GREEN
RB	General Purpose Particulate	1.00μ	OUT/IN	RED
RC	High Efficiency Particulate	0.01μ	OUT/IN	BLUE
RD	Vapor Absorbing	0.01μ	OUT/IN	BLACK

WARNINGS

- READ INSTRUCTIONS CAREFULLY BEFORE INSTALLING NEW ELEMENT.
- DO NOT REPLACE ANY ITEM ON FILTER WHILE IT IS UNDER PRESSURE.
- DO NOT OPERATE IF THERE IS A LEAK IN FILTER. TAKE FILTER OUT OF SERVICE IMMEDIATELY.
- DO NOT OPERATE ABOVE MAXIMUM WORKING PRESSURE (MWP) AT MAXIMUM OPERATING TEMPERATURE (°F).

ELEMENT REPLACEMENT

IMPORTANT

TO REDUCE ENERGY CONSUMPTION FROM EXCESSIVE PRESSURE DROP AND MINIMIZE CHANCE OF CONTAMINANT CARRYOVER, INSTALL NEW ELEMENT WHEN PRESSURE DROP REACHES 10 PSID (EXCEPT GRADE RD). INSTALL NEW RD ELEMENTS WHEN HYDROCARBON VAPORS ARE FIRST DETECTED DOWNSTREAM OR AT LEAST EVERY 6 MONTHS.

1. Close inlet and outlet shutoff valves (and open bypass valve if provided), or lock out all compressed air supply to filter housing.
2. On units with auto drain valve, push a 3/16" allen wrench into the ADM-2 or ADM-2-2 outlet (See Figure 1) to open valve. (Note: stand clear of outlet, liquids may be released.) Leave valve open until all pressure is out of the filter housing. On units with a manual drain valve, stand clear and turn manual valve (petcock) until full open. Leave valve open until all pressure is out of filter housing and bowl is removed.

FIGURE 1 ADM-2 & ADM-2-2 MANUAL OVERRIDE

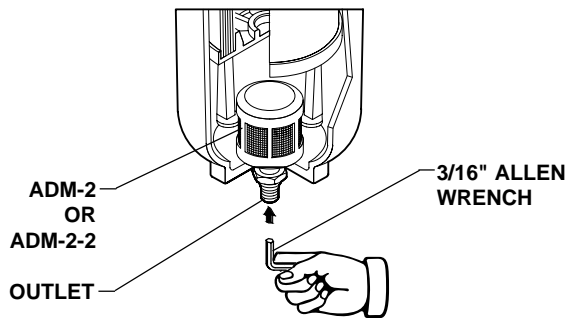

NOTE: LIQUIDS MAY BE RELEASED. WEAR GLOVES TO KEEP HANDS CLEAN AND EYE PROTECTION.

WARNING

DO NOT UNSCREW FILTER BOWL FROM HEAD UNTIL VESSEL IS COMPLETELY DEPRESSURIZED.

3. After all pressure is out of filter, grasp filter bowl firmly with both hands (models F200-15-1/4 through F200-55-1/2) or place strap wrench around the bowl (models F200-85-3/4 through F200-1000-3). Turn bowl counterclockwise as you face the bottom to unscrew from filter head. If preferred, strap wrenches can be used on all bowls. Make sure that the bowl does not drop.

WARNING

ON MODELS F200-600-3 AND LARGER, PROVIDE SUPPORT UNDER BOWL BEFORE REMOVING. BOWL IS HEAVY AND COULD CAUSE INJURY IF ALLOWED TO FALL.

4. Remove used element from element adaptor in filter head by pulling downward. Discard used element properly.
5. Remove new element from package and plastic bag. Check to make sure that o-ring is properly positioned in endcap and has been lightly greased.

6. Grasp clean element by bottom endcap and push element onto element adaptor firmly, but do not force beyond normal stop.
7. Check o-ring in filter head. Replace if worn or damaged.
8. Clean and lubricate threads on bowl with light grease. This will facilitate removal of bowl at next servicing.
9. Carefully raise filter bowl over element and screw into head, then tighten. **DO NOT OVERTIGHTEN.**
10. Close manual override if automatic drain or manual drain valve (petcock); then slowly open inlet and outlet shutoff valves. Close bypass valve (if provided). Filter is now in service.
11. Monitor differential pressure regularly and replace element as indicated.

E100 FILTER ELEMENTS

Many E200 series replacement elements fit in the F100 series filter housings. See **E100 & E200 Replacement Elements** Table below for a cross reference of both series.

E100 & E200 REPLACEMENT ELEMENTS

F100 FILTER MODEL	E100 ELEMENT MODEL	E200 ELEMENT MODEL
F100-15-(*)	E100-15-(*)	N/A
F100-30-(*)	E100-30-(*)	E200-55-(*)
F100-50-(*)	E100-50-(*)	N/A
F100-75-(*)	E100-75-(*)	E200-85-(*)
F100-100-(*)	E100-100-(*)	E200-100-(*)
F100-150-(*)	E100-150-(*)	E200-150-(*)
F100-225-(*)	E100-225-(*)	E200-265-(*)
F100-350-(*)	E100-350-(*)	N/A
F100-500-(*)	E100-500-(*)	N/A
F100-750-(*)	E100-750-(*)	E200-1000-(*)
F100-1000-(*)	E100-1000-(*)	N/A

(*)-Insert appropriate element grade here; for example E200-15-1/4-RB

Some E100 & E200 series replacement elements fit in the FHP series high pressure filter housings. See **E100/E200 Replacement Elements Used in FHP Filters** Table below for a cross reference of both series.

E100/E200 REPLACEMENT ELEMENTS USED IN FHP FILTERS

FHP FILTER MODEL	E100 ELEMENT MODEL	E200 ELEMENT MODEL
FHP-20-7.25-(*)	E100-15-(*)	N/A
FHP-40-7.25-(*)	E100-30-(*)	E200-55-(*)
FHP-70-7.25-(*)	E100-50-(*)	N/A
FHP-105-7.25-(*)	E100-105-(*)	N/A
FHP-200-7.25-(*)	E100-200-(*)	N/A
FHP-325-7.25-(*)	E100-325/400-(*)	N/A
FHP-400-7.25-(*)	E100-325/400-(*)	N/A

(*)-Insert appropriate element grade here; for example E100-15-RB

E200 FILTER ELEMENTS

Van Air E200 filter elements employ the same features as the E100 filter elements. For a reference on replacement element model and part numbers see **E200 Replacement Element** table on page 3.

E200 REPLACEMENT ELEMENTS

FILTER MODEL	ELEMENT MODEL	ELEMENT PART NUMBER	FILTER MODEL	ELEMENT MODEL	ELEMENT PART NUMBER
F200-15-1/4 THRU 25-1/2	E200-15/25-AA	26-10400	F200-265-1-1/4	E200-265-RB	26-2108
F200-15-1/4 THRU 25-1/2	E200-15/25-RAA	26-10401	F200-265-1-1/4	E200-265-C	26-2086
F200-15-1/4 THRU 25-1/2	E200-15/25-A	26-10402	F200-265-1-1/4	E200-265-RC	26-2119
F200-15-1/4 THRU 25-1/2	E200-15/25-RA	26-10403	F200-265-1-1/4	E200-265-RD	26-2156
F200-15-1/4 THRU 25-1/2	E200-15/25-B	26-10404	F200-350-1-1/2 & 400-2	E200-350/400-AA	26-10409
F200-15-1/4 THRU 25-1/2	E200-15/25-RB	26-10405	F200-350-1-1/2 & 400-2	E200-350/400-RAA	26-10410
F200-15-1/4 THRU 25-1/2	E200-15/25-C	26-10406	F200-350-1-1/2 & 400-2	E200-350/400-A	26-10411
F200-15-1/4 THRU 25-1/2	E200-15/25-RC	26-10407	F200-350-1-1/2 & 400-2	E200-350/400-RA	26-10412
F200-15-1/4 THRU 25-1/2	E200-15/25-RD	26-10408	F200-350-1-1/2 & 400-2	E200-350/400-B	26-10413
F200-55-1/2	E200-55-AA	26-10032	F200-350-1-1/2 & 400-2	E200-350/400-RB	26-10414
F200-55-1/2	E200-55-RAA	26-10107	F200-350-1-1/2 & 400-2	E200-350/400-C	26-10415
F200-55-1/2	E200-55-A	26-2059	F200-350-1-1/2 & 400-2	E200-350/400-RC	26-10416
F200-55-1/2	E200-55-RA	26-2092	F200-350-1-1/2 & 400-2	E200-350/400-RD	26-10417
F200-55-1/2	E200-55-B	26-2070	F200-500-2	E200-500-AA	26-10418
F200-55-1/2	E200-55-RB	26-2103	F200-500-2	E200-500-RAA	26-10419
F200-55-1/2	E200-55-C	26-2081	F200-500-2	E200-500-A	26-10420
F200-55-1/2	E200-55-RC	26-2114	F200-500-2	E200-500-RA	26-10421
F200-55-1/2	E200-55-RD	26-2151	F200-500-2	E200-500-B	26-10422
F200-85-3/4	E200-85-AA	26-10034	F200-500-2	E200-500-RB	26-10423
F200-85-3/4	E200-85-RAA	26-10109	F200-500-2	E200-500-C	26-10424
F200-85-3/4	E200-85-A	26-2061	F200-500-2	E200-500-RC	26-10425
F200-85-3/4	E200-85-RA	26-2094	F200-500-2	E200-500-RD	26-10426
F200-85-3/4	E200-85-B	26-2072	F200-600-3	E200-600-AA	26-10427
F200-85-3/4	E200-85-RB	26-2105	F200-600-3	E200-600-RAA	26-10428
F200-85-3/4	E200-85-C	26-2083	F200-600-3	E200-600-A	26-10429
F200-85-3/4	E200-85-RC	26-2116	F200-600-3	E200-600-RA	26-10430
F200-85-3/4	E200-85-RD	26-2153	F200-600-3	E200-600-B	26-10431
F200-100-1	E200-100-AA	26-10035	F200-600-3	E200-600-RB	26-10432
F200-100-1	E200-100-RAA	26-10110	F200-600-3	E200-600-C	26-10433
F200-100-1	E200-100-A	26-2062	F200-600-3	E200-600-RC	26-10434
F200-100-1	E200-100-RA	26-2095	F200-600-3	E200-600-RD	26-10435
F200-100-1	E200-100-B	26-2073	F200-800-3	E200-800-AA	26-10436
F200-100-1	E200-100-RB	26-2106	F200-800-3	E200-800-RAA	26-10437
F200-100-1	E200-100-C	26-2084	F200-800-3	E200-800-A	26-10438
F200-100-1	E200-100-RC	26-2117	F200-800-3	E200-800-RA	26-10439
F200-100-1	E200-100-RD	26-2154	F200-800-3	E200-800-B	26-10440
F200-150-1	E200-150-AA	26-10036	F200-800-3	E200-800-RB	26-10441
F200-150-1	E200-150-RAA	26-10111	F200-800-3	E200-800-C	26-10442
F200-150-1	E200-150-A	26-2063	F200-800-3	E200-800-RC	26-10443
F200-150-1	E200-150-RA	26-2096	F200-800-3	E200-800-RD	26-10444
F200-150-1	E200-150-B	26-2074	F200-1000-3	E200-1000-AA	26-10040
F200-150-1	E200-150-RB	26-2107	F200-1000-3	E200-1000-RAA	26-10115

WARRANTY

I. INSTALLATION.

Unless otherwise set forth in a quotation and/or acknowledgment, Seller shall not be responsible for installation. Cost of and all risks of damage to the equipment and/or components thereof caused by installation shall be the sole responsibility of Buyer. If supervision of installation and/or supervision of start up of the equipment is to be provided by Seller, Buyer shall assume all costs incurred by Seller in furnishing supervision. If supervision of installation and/or supervision of start up of the equipment is provided by Seller, Seller shall only be responsible for any loss or damage growing out of a direct negligent act or acts of Seller's supervisor.

SELLER SHALL NOT BE RESPONSIBLE FOR IMPROPER OPERATION OF THE EQUIPMENT DUE TO FAULTY ERECTION OR INSTALLATION.

II. PERFORMANCE.

Seller shall have no responsibility for the performance of its Goods when installed under conditions varying materially from those under which the product is usually tested or operated under existing industry standards.

III. WARRANTY

All filter housings are guaranteed to be free of defective materials and workmanship for a period of **five (5) years** from the date of shipment when used in compressed air applications. This warranty does not include elements, drain line components, gaskets, o-rings or any other types of seals, accessories or expendable items.

All goods manufactured by Seller are guaranteed to be free from defective materials and workmanship for a period of one (1) year from date of shipment. The equipment and accessories sold but not manufactured by Seller are guaranteed only to the extent that either Seller or Buyer is able to recover under the manufacturer's warranty. This warranty shall not be assignable to buyer.

The above warranties for all products described do not cover abuse, neglect, lack of normal maintenance, accidents or other exceptional circumstances.

Date of shipment will be defined as the date of departure from the factory or from distributor stock. A copy of the distributor invoice to the customer at time of shipment is required as verification of shipment from distributor stock. Equipment start up will be verified by receipt of the product registration card.

Seller's obligation under this warranty may, at its option, be discharged by furnishing or repairing, without charge, FOB its factory, a similar part to replace any part of its own manufacture which within the above specified periods, proves to have been defective, provided that within a reasonable time for inspection after delivery, Seller is notified of such defects and the equipment, material or part claimed to be defective is delivered pre-paid to Seller at Lake City, Pennsylvania with evidence that it has been properly maintained and used in accordance with instructions. If, in connection with such warranties, repairs are performed by the Buyer with the written authorization of Seller, then the expense in connection with such repairs shall not exceed the cost of material and direct labor. If such repairs are performed by Buyer without the written authorization of Seller, Seller will not assume any of the expenses in connection with such repairs and will immediately void any remaining warranty on the Goods.

THE REPAIR OR REPLACEMENT WARRANTY HEREIN SET FORTH IS THE EXCLUSIVE WARRANTY GIVEN BY SELLER FOR ITS GOODS. THIS WARRANTY IS GIVEN IN LIEU OF ANY OR ALL WARRANTIES, WHETHER WRITTEN OR ORAL, EXPRESSED OR IMPLIED. ANY AND ALL IMPLIED WARRANTIES OF MERCHANTABILITY OR FITNESS FOR ANY PARTICULAR PURPOSE ARE HEREBY EXPRESSLY EXCLUDED BY SELLER. SELLER NEITHER ASSUMES, NOR DOES IT AUTHORIZE ANY OTHER PERSON TO ASSUME ON ITS BEHALF ANY OTHER LIABILITY IN CONNECTION WITH THE SALE OF ITS GOODS.

IV. LIMITATIONS OF LIABILITIES AND INDEMNITIES.

IN NO CASE, WHETHER AS A RESULT OF BREACH OF CONTRACT, BREACH OF WARRANTY OR TORT (INCLUDING SELLER'S OR BUYER'S NEGLIGENCE OR STRICT LIABILITY) SHALL SELLER BE LIABLE FOR ANY CONSEQUENTIAL OR INCIDENTAL DAMAGES INCURRED BY BUYER, INCLUDING, BUT NOT LIMITED TO, LOSS OF SALES PROFIT, REVENUE, OR GOOD WILL; LOSS OF USE OF GOODS OR ANY ASSOCIATED EQUIPMENT OR MATERIAL; COST OF CAPITAL; COST OF SUBSTITUTE PRODUCTS, FACILITIES OR SERVICES; DOWN TIME COSTS; ATTORNEY'S FEES; OR LOSSES OR CLAIMS OF CUSTOMERS OF BUYER FOR SUCH DAMAGES BUYER HEREBY AGREES TO INDEMNIFY AND HOLD HARMLESS SELLER FROM ANY AND ALL SUCH DAMAGES. BUYER FURTHER AGREES TO DEFEND, INDEMNIFY AND HOLD HARMLESS SELLER FROM ANY AND ALL CLAIMS, LIABILITY, DAMAGES OR EXPENSES (INCLUDING ATTORNEY'S FEES) DUE TO PERSONAL INJURIES OR DEATH, TO BUYER, ITS EMPLOYEES, AND THIRD PARTIES AND FROM PROPERTY DAMAGE RESULTING FROM THE NEGLIGENCE OR STRICT LIABILITY OF BUYER NOT WITHSTANDING THE PROVISIONS OF ANY WORKER COMPENSATION OR SIMILAR STATUTE.

V. SERVICE, OPERATING PROCEDURE, WARNINGS.

Should Buyer request start up supervision by Seller, a maximum number of days required for this supervision may be included and specified in the quotation and/or acknowledgment as a separate price item. The specified days are only approximate, since start up supervision is contingent upon equipment and work supplied by others and beyond the control of Seller, and Seller shall be paid for any days actually worked in addition to those specified on a pro-rata basis.

Start up supervision and warranty supervision and warranty service time will include all elapsed time during the standard working hours, as defined by Seller, or Seller's representative from the time Seller's representative leaves his operating base or another customer's plant.

Where the service to be performed is start up supervision, Seller should be notified approximately 30 days prior to start up. Seller's representatives may be required to have standard time verification sheets approved by Buyer's authorized representative, and the name and title of this representative should be furnished to Seller with the notification.

Unless set forth in the quotation and/or acknowledgment, Seller shall not be obligated to provide special operating manuals or operating procedures for the operation of its equipment or supply special warning placards to be affixed to the equipment. If such manuals, procedures or placards are provided by Seller, Buyer shall be responsible for payment of cost of furnishing such items, for instructing any operator of the equipment as to the contents of such manuals and/or procedures; for requiring that such procedures be abided by; for insuring that warning placards remain affixed to the equipment and for requiring operators to abide by warning placards.

Any safety equipment required to be worn by any operator or maintenance person shall be provided by Buyer, and the failure to provide such equipment or the failure to require the use thereof shall be the Buyer's sole responsibility. Buyer shall indemnify and hold Seller harmless for any liability with respect thereto.

Seller shall not be responsible for providing safety devices and/or guarding of the equipment except as provided for in the quotation and/or acknowledgment, and Buyer specifically assumes all responsibility for supplying such safety devices and/or guarding necessary for the safe operation of the equipment. If safety devices and/or guarding are specified in the quotation and/or acknowledgment, Buyer shall be solely responsible for making certain that any operator of the equipment uses such safety devices and/or guarding and Buyer shall indemnify and hold Seller harmless with respect to any property damage and/or personal injury, including death, occasioned by any person by reason of such failure on the part of Buyer and/or its operator.

VAN AIR SYSTEMS INC
MAKING COMPRESSED AIR AND GAS WORK BETTER SINCE 1944.

2950 Mechanic Street
Lake City, PA 16423-2095
Phone: 814/774-2631
Fax: 814/774-3482