

Moisture Separator

Reliable Separator for Contaminant Removal.

Van Air's Moisture Separators remove compressor lubricant, oil aerosols, and moisture from compressed Air Systems. These separators have flow capacities up to 800 SCFM at 100 psig and available in 1/2" through 3" connection sizes. The moisture separator housings are made of cast aluminum and they are coated for corrosion resistance. Each Moisture Separator requires no electricity and includes a push-on cartridge and manual or automatic drain valve.

F E A T U R E S

Cyclonic separation technology

Lifetime warranty

No electricity required

Flows up to 800 SCFM



BENEFITS OF THE MOISTURE SEPARATOR

Reliable // Easy to use // Affordable

vanairsystems.com

STANDARD EQUIPMENT

- Push on element cartridge
- ADM-3 automatic drain valve
- E-coated and epoxy powder coated separator housing
- 800 SCFM Max Flow Rating
- Lifetime warranty

OPTIONAL EQUIPMENT

- Drain kits
- Wall mounting kits
- Connector kits for an F200 Filter

DIMENSIONS & SPECIFICATIONS

Model	Part Number	Flow Rating (SCFM)	In/Out Conn. (In.)	Height (In.)	Width (In.)	Weight (lbs.)
Manual Separators						
SEP-25-M	80-0860	25	½ NPT	10 5/16	2 13/16	1.7
SEP-55-M	83-0861	55	½ NPT	12 1/8	3 7/16	2.2
SEP-100-M	83-0862	100	1 NPT	14 5/8	5	5.7
SEP-265-M	83-0863	265	1 ¼ NPT	20 7/16	4 15/16	7.7
SEP-350-M	83-0864	350	1 ½ NPT	21 1/2	5 5/16	8.7
SEP-500-M	83-0865	500	2 NPT	29 7/16	5 5/16	9.9
SEP-800-M	83-0866	800	3 NPT	31 3/8	7 7/8	21.9
Automatic Separators						
SEP-25-AD	83-0850	25	½ NPT	10 5/16	2 13/16	1.7
SEP-55-AD	83-0851	55	½ NPT	12 1/8	3 7/16	2.2
SEP-100-AD	83-0852	100	1 NPT	14 5/8	5	5.7
SEP-265-AD	83-0853	265	1 ¼ NPT	20 7/16	4 15/16	7.7
SEP-350-AD	83-0854	350	1 ½ NPT	21 1/2	5 5/16	8.7
SEP-500-AD	83-0855	500	2 NPT	29 7/16	5 5/16	9.9
SEP-800-AD	83-0856	800	3 NPT	31 3/8	7 7/8	21.9

MODEL:
SEP-25

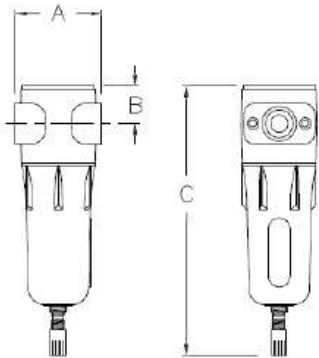

MODELS:
SEP-55 SEP-350
SEP-100 SEP-500

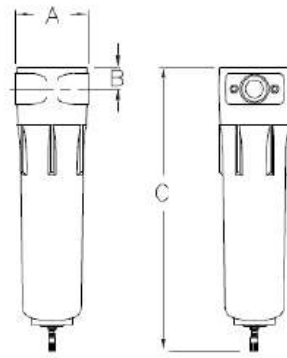

MODEL:
SEP-800

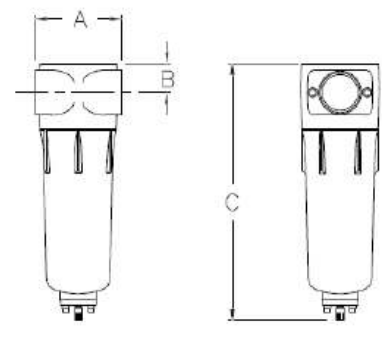

2950 Mechanic Street, Lake City, PA 16423, USA | Toll Free Phone 800-840-9906 | Corporate Fax 814-774-0778 | Order Entry Fax 814-774-3482

Distributed By:



Moisture Separators- PDF Downloads

Instruction Manuals

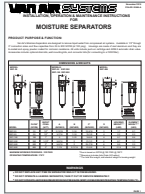

Sales Drawings

